



LG

Life's Good

Internal Use Only

LED TV

SERVICE MANUAL

CHASSIS : LA5CB

MODEL : 49LX340H 49LX340H-U*

CAUTION

BEFORE SERVICING THE CHASSIS, READ THE SAFETY PRECAUTIONS IN THIS MANUAL.

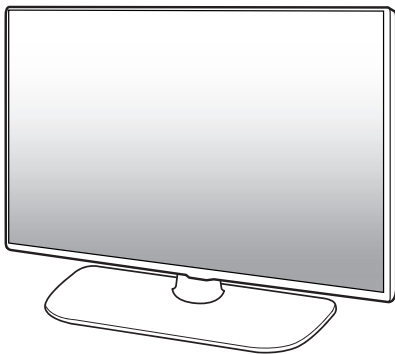

P/NO : MFL69152122 (1611-REV01)

CONTENTS

CONTENTS	2
SAFETY PRECAUTIONS	3
SERVICING PRECAUTIONS	4
SPECIFICATION	6
USB DOWNLOAD	9
TROUBLESHOOTING GUIDE.....	10
BLOCK DIAGRAM.....	16
EXPLODED VIEW	17

SAFETY PRECAUTIONS

IMPORTANT SAFETY NOTICE

Many electrical and mechanical parts in this chassis have special safety-related characteristics. These parts are identified by \triangle in the Exploded View.

It is essential that these special safety parts should be replaced with the same components as recommended in this manual to prevent Shock, Fire, or other Hazards.

Do not modify the original design without permission of manufacturer.

General Guidance

An **isolation Transformer should always be used** during the servicing of a receiver whose chassis is not isolated from the AC power line. Use a transformer of adequate power rating as this protects the technician from accidents resulting in personal injury from electrical shocks.

It will also protect the receiver and its components from being damaged by accidental shorts of the circuitry that may be inadvertently introduced during the service operation.

If any fuse (or Fusible Resistor) in this TV receiver is blown, replace it with the specified.

When replacing a high wattage resistor (Oxide Metal Film Resistor, over 1 W), keep the resistor 10 mm away from PCB.

Keep wires away from high voltage or high temperature parts.

Before returning the receiver to the customer,

always perform an **AC leakage current check** on the exposed metallic parts of the cabinet, such as antennas, terminals, etc., to be sure the set is safe to operate without damage of electrical shock.

Leakage Current Cold Check(Antenna Cold Check)

With the instrument AC plug removed from AC source, connect an electrical jumper across the two AC plug prongs. Place the AC switch in the on position, connect one lead of ohm-meter to the AC plug prongs tied together and touch other ohm-meter lead in turn to each exposed metallic parts such as antenna terminals, phone jacks, etc.

If the exposed metallic part has a return path to the chassis, the measured resistance should be between 1 M Ω and 5.2 M Ω .

When the exposed metal has no return path to the chassis the reading must be infinite.

An other abnormality exists that must be corrected before the receiver is returned to the customer.

Leakage Current Hot Check (See below Figure)

Plug the AC cord directly into the AC outlet.

Do not use a line Isolation Transformer during this check.

Connect 1.5 K / 10 watt resistor in parallel with a 0.15 uF capacitor between a known good earth ground (Water Pipe, Conduit, etc.) and the exposed metallic parts.

Measure the AC voltage across the resistor using AC voltmeter with 1000 ohms/volt or more sensitivity.

Reverse plug the AC cord into the AC outlet and repeat AC voltage measurements for each exposed metallic part. Any voltage measured must not exceed 0.75 volt RMS which corresponds to 0.5 mA.

In case any measurement is out of the limits specified, there is possibility of shock hazard and the set must be checked and repaired before it is returned to the customer.

Leakage Current Hot Check circuit

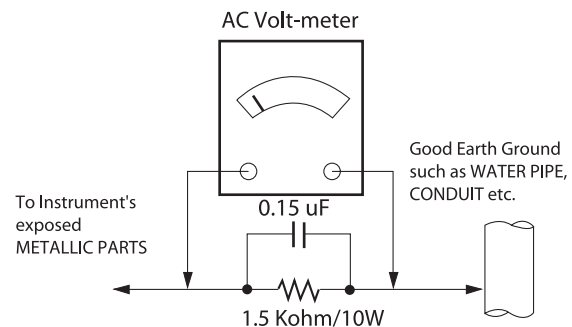

When 25A is impressed between Earth and 2nd Ground for 1 second, Resistance must be less than 0.1 Ω

*Base on Adjustment standard

SERVICING PRECAUTIONS

CAUTION: Before servicing receivers covered by this service manual and its supplements and addenda, read and follow the **SAFETY PRECAUTIONS** on page 3 of this publication.
NOTE: If unforeseen circumstances create conflict between the following servicing precautions and any of the safety precautions on page 3 of this publication, always follow the safety precautions. Remember: Safety First.

General Servicing Precautions

1. Always unplug the receiver AC power cord from the AC power source before;
 - a. Removing or reinstalling any component, circuit board module or any other receiver assembly.
 - b. Disconnecting or reconnecting any receiver electrical plug or other electrical connection.
 - c. Connecting a test substitute in parallel with an electrolytic capacitor in the receiver.
CAUTION: A wrong part substitution or incorrect polarity installation of electrolytic capacitors may result in an explosion hazard.
2. Test high voltage only by measuring it with an appropriate high voltage meter or other voltage measuring device (DVM, FETVOM, etc) equipped with a suitable high voltage probe. Do not test high voltage by "drawing an arc".
3. Do not spray chemicals on or near this receiver or any of its assemblies.
4. Unless specified otherwise in this service manual, clean electrical contacts only by applying the following mixture to the contacts with a pipe cleaner, cotton-tipped stick or comparable non-abrasive applicator; 10 % (by volume) Acetone and 90 % (by volume) isopropyl alcohol (90 % - 99 % strength)
CAUTION: This is a flammable mixture.
Unless specified otherwise in this service manual, lubrication of contacts is not required.
5. Do not defeat any plug/socket B+ voltage interlocks with which receivers covered by this service manual might be equipped.
6. Do not apply AC power to this instrument and/or any of its electrical assemblies unless all solid-state device heat sinks are correctly installed.
7. Always connect the test receiver ground lead to the receiver chassis ground before connecting the test receiver positive lead.
Always remove the test receiver ground lead last.
8. Use with this receiver only the test fixtures specified in this service manual.
CAUTION: Do not connect the test fixture ground strap to any heat sink in this receiver.

Electrostatically Sensitive (ES) Devices

Some semiconductor (solid-state) devices can be damaged easily by static electricity. Such components commonly are called Electrostatically Sensitive (ES) Devices. Examples of typical ES devices are integrated circuits and some field-effect transistors and semiconductor "chip" components. The following techniques should be used to help reduce the incidence of component damage caused by static by static electricity.

1. Immediately before handling any semiconductor component or semiconductor-equipped assembly, drain off any electrostatic charge on your body by touching a known earth ground. Alternatively, obtain and wear a commercially available discharging wrist strap device, which should be removed to prevent potential shock reasons prior to applying power to the unit under test.

2. After removing an electrical assembly equipped with ES devices, place the assembly on a conductive surface such as aluminum foil, to prevent electrostatic charge buildup or exposure of the assembly.
3. Use only a grounded-tip soldering iron to solder or unsolder ES devices.
4. Use only an anti-static type solder removal device. Some solder removal devices not classified as "anti-static" can generate electrical charges sufficient to damage ES devices.
5. Do not use freon-propelled chemicals. These can generate electrical charges sufficient to damage ES devices.
6. Do not remove a replacement ES device from its protective package until immediately before you are ready to install it. (Most replacement ES devices are packaged with leads electrically shorted together by conductive foam, aluminum foil or comparable conductive material).
7. Immediately before removing the protective material from the leads of a replacement ES device, touch the protective material to the chassis or circuit assembly into which the device will be installed.
CAUTION: Be sure no power is applied to the chassis or circuit, and observe all other safety precautions.
8. Minimize bodily motions when handling unpackaged replacement ES devices. (Otherwise harmless motion such as the brushing together of your clothes fabric or the lifting of your foot from a carpeted floor can generate static electricity sufficient to damage an ES device.)

General Soldering Guidelines

1. Use a grounded-tip, low-wattage soldering iron and appropriate tip size and shape that will maintain tip temperature within the range or 500 °F to 600 °F.
2. Use an appropriate gauge of RMA resin-core solder composed of 60 parts tin/40 parts lead.
3. Keep the soldering iron tip clean and well tinned.
4. Thoroughly clean the surfaces to be soldered. Use a small wire-bristle (0.5 inch, or 1.25 cm) brush with a metal handle. Do not use freon-propelled spray-on cleaners.
5. Use the following unsoldering technique
 - a. Allow the soldering iron tip to reach normal temperature. (500 °F to 600 °F)
 - b. Heat the component lead until the solder melts.
 - c. Quickly draw the melted solder with an anti-static, suction-type solder removal device or with solder braid.
CAUTION: Work quickly to avoid overheating the circuit board printed foil.
6. Use the following soldering technique.
 - a. Allow the soldering iron tip to reach a normal temperature (500 °F to 600 °F)
 - b. First, hold the soldering iron tip and solder the strand against the component lead until the solder melts.
 - c. Quickly move the soldering iron tip to the junction of the component lead and the printed circuit foil, and hold it there only until the solder flows onto and around both the component lead and the foil.
CAUTION: Work quickly to avoid overheating the circuit board printed foil.
 - d. Closely inspect the solder area and remove any excess or splashed solder with a small wire-bristle brush.

IC Remove/Replacement

Some chassis circuit boards have slotted holes (oblong) through which the IC leads are inserted and then bent flat against the circuit foil. When holes are the slotted type, the following technique should be used to remove and replace the IC. When working with boards using the familiar round hole, use the standard technique as outlined in paragraphs 5 and 6 above.

Removal

1. Desolder and straighten each IC lead in one operation by gently prying up on the lead with the soldering iron tip as the solder melts.
2. Draw away the melted solder with an anti-static suction-type solder removal device (or with solder braid) before removing the IC.

Replacement

1. Carefully insert the replacement IC in the circuit board.
2. Carefully bend each IC lead against the circuit foil pad and solder it.
3. Clean the soldered areas with a small wire-bristle brush. (It is not necessary to reapply acrylic coating to the areas).

"Small-Signal" Discrete Transistor Removal/Replacement

1. Remove the defective transistor by clipping its leads as close as possible to the component body.
2. Bend into a "U" shape the end of each of three leads remaining on the circuit board.
3. Bend into a "U" shape the replacement transistor leads.
4. Connect the replacement transistor leads to the corresponding leads extending from the circuit board and crimp the "U" with long nose pliers to insure metal to metal contact then solder each connection.

Power Output, Transistor Device Removal/Replacement

1. Heat and remove all solder from around the transistor leads.
2. Remove the heat sink mounting screw (if so equipped).
3. Carefully remove the transistor from the heat sink of the circuit board.
4. Insert new transistor in the circuit board.
5. Solder each transistor lead, and clip off excess lead.
6. Replace heat sink.

Diode Removal/Replacement

1. Remove defective diode by clipping its leads as close as possible to diode body.
2. Bend the two remaining leads perpendicular y to the circuit board.
3. Observing diode polarity, wrap each lead of the new diode around the corresponding lead on the circuit board.
4. Securely crimp each connection and solder it.
5. Inspect (on the circuit board copper side) the solder joints of the two "original" leads. If they are not shiny, reheat them and if necessary, apply additional solder.

Fuse and Conventional Resistor Removal/Replacement

1. Clip each fuse or resistor lead at top of the circuit board hollow stake.
2. Securely crimp the leads of replacement component around notch at stake top.

3. Solder the connections.

CAUTION: Maintain original spacing between the replaced component and adjacent components and the circuit board to prevent excessive component temperatures.

Circuit Board Foil Repair

Excessive heat applied to the copper foil of any printed circuit board will weaken the adhesive that bonds the foil to the circuit board causing the foil to separate from or "lift-off" the board. The following guidelines and procedures should be followed whenever this condition is encountered.

At IC Connections

To repair a defective copper pattern at IC connections use the following procedure to install a jumper wire on the copper pattern side of the circuit board. (Use this technique only on IC connections).

1. Carefully remove the damaged copper pattern with a sharp knife. (Remove only as much copper as absolutely necessary).
2. Carefully scratch away the solder resist and acrylic coating (if used) from the end of the remaining copper pattern.
3. Bend a small "U" in one end of a small gauge jumper wire and carefully crimp it around the IC pin. Solder the IC connection.
4. Route the jumper wire along the path of the out-away copper pattern and let it overlap the previously scraped end of the good copper pattern. Solder the overlapped area and clip off any excess jumper wire.

At Other Connections

Use the following technique to repair the defective copper pattern at connections other than IC Pins. This technique involves the installation of a jumper wire on the component side of the circuit board.

1. Remove the defective copper pattern with a sharp knife. Remove at least 1/4 inch of copper, to ensure that a hazardous condition will not exist if the jumper wire opens.
2. Trace along the copper pattern from both sides of the pattern break and locate the nearest component that is directly connected to the affected copper pattern.
3. Connect insulated 20-gauge jumper wire from the lead of the nearest component on one side of the pattern break to the lead of the nearest component on the other side. Carefully crimp and solder the connections.
CAUTION: Be sure the insulated jumper wire is dressed so the it does not touch components or sharp edges.

SPECIFICATION

NOTE : Specifications and others are subject to change without notice for improvement.

1. Application range

This spec sheet is applied LED TV with LA5CB chassis

3. Test method

- 1) Performance: LGE TV test method followed
- 2) Demanded other specification
 - Safety : CE, IEC specification
 - EMC : CE, IEC specification

2. Requirement for Test

Each part is tested as below without special appointment.

- 1) Temperature: 25 °C ± 5 °C(77 °F ± 9 °F), CST: 40 °C ± 5 °C
- 2) Relative Humidity: 65 % ± 10 %
- 3) Power Voltage
 - : Standard input voltage (AC 100-240 V~, 50/60 Hz)
 - * Standard Voltage of each products is marked by models.
- 4) Specification and performance of each parts are followed each drawing and specification by part number in accordance with BOM.
- 5) The receiver must be operated for about 5 minutes prior to the adjustment.

4. General Specification

No	Item		Specification	Result	Remark
1.	Receiving System		ATSC / NTSC-M / 64 & 256 QAM		
2.	Available Channel		1) VHF : 02~13 2) UHF : 14~69 3) DTV : 02-69 4) CATV : 01~135 5) CADTV : 01~135		
3.	Input Voltage		AC 100 ~ 240V 50/60Hz		Mark : 110V, 60Hz (N.America)
4.	Market		NORTH AMERICA		
5.	Screen Size		60/65 inch Wide (1920 × 1080)	FHD + 120Hz	All models without HD models
			42/43/49/55 inch Wide (1920 × 1080)	FHD + 60Hz	All models without HD models
			28/32 inch Wide (1366 × 768)	HD + 60Hz	
6.	Aspect Ratio		16:9		
7.	Tuning System		FS		
8.	Module	Direct	HC275EXN-VSDP1	CSOT	28LX330C-UA
			LC320DUE-FHA3	LGD	32LX340H-UA
			LC320DXE-MGA3	LGD	32LX330C -UA
			HC400DUN-VCKN5	INX	40LX340H-UA
			LC420DUE-MGA3	LGD	42LX330C -UA, 42LX530S-UA
			NC430EUN-AACR1	LGD	43LX310C-UA
			LC430EUE-FHM3	LGD	43LX340H-UA
			NC490EUN-AACR1	LGD	49LX310C-UA
			LC490EUE-FHM3	LGD	49LX341C -UA, 49LX340H-UA 49LX540S-UA
			LC550EUE-FHM3	LGD	55LX341C -UA, 55LX340H-UA, 55LX540S-UA
			NC600EUF-VSCN1/3	Sharp	60LX341C-UA, 60LX540S-UA
LC650EUF-FHM3	LGD	65LX341C-UA, 65LX540S-UA			
9.	Operating Environment		1) Temp : 0 ~ 40 deg 2) Humidity : ~ 80 %		
10.	Storage Environment		1) Temp : -20 ~ 60 deg 2) Humidity : ~ 85 %		

5. Supported video resolutions

5.1. RGB Input (PC)

No	Resolution	H-freq(kHz)	V-freq.(Hz)	Pixel clock(MHz)	Proposed	DDC
1.	640*350	31.46	70.09	25.17	EGA	X
2.	720*400	31.46	70.08	28.32	DOS	O
3.	640*480	31.46	59.94	25.17	VESA(VGA)	O
4.	800*600	37.87	60.31	40.00	VESA(SVGA)	O
5.	1024*768	48.36	60.00	65.00	VESA(XGA)	O
6.	1152*864	54.34	60.05	81.62	VESA	O
7.	1360*768	47.71	60.01	85.50	VESA (WXGA)	O
8.	1280*1024	63.98	60.02	108.0	VESA (SXGA)	O
9.	1920*1080	67.50	60.00	148.5	HDTV 1080P	O

5.2. Component input(Y, CB/PB, CR/PR)

No	Resolution	H-freq(kHz)	V-freq.(Hz)	Pixel clock(MHz)	Proposed	Remark
1.	720*480	15.73	60.00	13.513	SDTV ,DVD 480I	
2.	720*480	15.73	59.94	13.500	SDTV ,DVD 480I	
3.	720*480	31.50	60.00	27.027	SDTV 480P	
4.	720*480	31.47	59.94	27.000	SDTV 480P	
5.	1280*720	45.00	60.00	74.250	HDTV 720P	
6.	1280*720	44.96	59.94	74.176	HDTV 720P	
7.	1920*1080	33.75	60.00	74.250	HDTV 1080I	
8.	1920*1080	33.72	59.94	74.176	HDTV 1080I	
9.	1920*1080	67.50	60.00	148.500	HDTV 1080P	
10.	1920*1080	67.432	59.94	148.352	HDTV 1080P	
11.	1920*1080	27.00	24.00	74.250	HDTV 1080P	
12.	1920*1080	26.97	23.976	74.176	HDTV 1080P	
13.	1920*1080	33.75	30.00	74.250	HDTV 1080P	
14.	1920*1080	33.71	29.97	74.176	HDTV 1080P	

5.3. HDMI Input 1 (PC/DTV)

No	Resolution	H-freq(kHz)	V-freq.(Hz)	Pixel clock(MHz)	Proposed	DDC
PC (DVI)					DDC	
1.	640*350	31.46	70.09	25.17	EGA	X
2.	720*400	31.46	70.08	28.32	DOS	O
3.	640*480	31.46	59.94	25.17	VESA(VGA)	O
4.	800*600	37.87	60.31	40.00	VESA(SVGA)	O
5.	1024*768	48.36	60.00	65.00	VESA(XGA)	O
6.	1152*864	54.34	60.05	81.62	VESA	O
7.	1360*768	47.71	60.01	85.50	VESA (WXGA)	O
8.	1280*1024	63.98	60.02	108.0	VESA (SXGA)	O
9.	1920*1080	67.50	60.00	148.5	HDTV 1080P	O
DTV						
1	720*480	31.50	60.00	27.027	SDTV 480P	
2	720*480	31.47	59.94	27.00	SDTV 480P	
3	1280*720	45.00	60.00	74.25	HDTV 720P	
4	1280*720	44.96	59.94	74.176	HDTV 720P	
5	1920*1080	33.75	60.00	74.25	HDTV 1080I	
6	1920*1080	33.72	59.94	74.176	HDTV 1080I	
7	1920*1080	67.50	60.00	148.50	HDTV 1080P	
8	1920*1080	67.43	59.94	148.352	HDTV 1080P	
9	1920*1080	27.00	24.00	74.25	HDTV 1080P	
10	1920*1080	26.97	23.97	74.176	HDTV 1080P	
11	1920*1080	33.75	30.00	74.25	HDTV 1080P	
12	1920*1080	33.71	29.97	74.176	HDTV 1080P	

USB DOWNLOAD

- (1) Put the USB Stick to the USB socket
- (2) Automatically detecting update file in USB Stick
 - If your downloaded program version in USB Stick is Lower, it didn't work.
 - But your downloaded version is Higher, USB data is automatically detecting (Download Version High & Power only mode, Set is automatically Download)
- (3) Show the message "Copying files from memory"



- (4) Updating is starting.

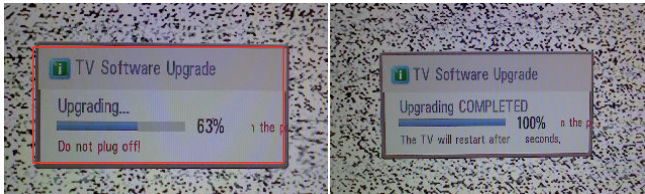

- (5) Updating Completed, the TV will restart automatically.
- (6) If your TV is turned on, check your updated version and Tool option. (explain the Tool option, next stage)
 - * If downloading version is more high than your TV have, TV can lost all channel data. In this case, you have to channel recover. if all channel data is cleared, you didn't have a DTV/ATV test on production line.

* After downloading, have to adjust Tool Option again.

- (1) Push "IN-START" key in service remote control.
- (2) Select "Tool Option 1" and push "OK" key.
- (3) Punch in the number. (Each model has their number)

TROUBLE SHOOTING

1. Power-up boot check

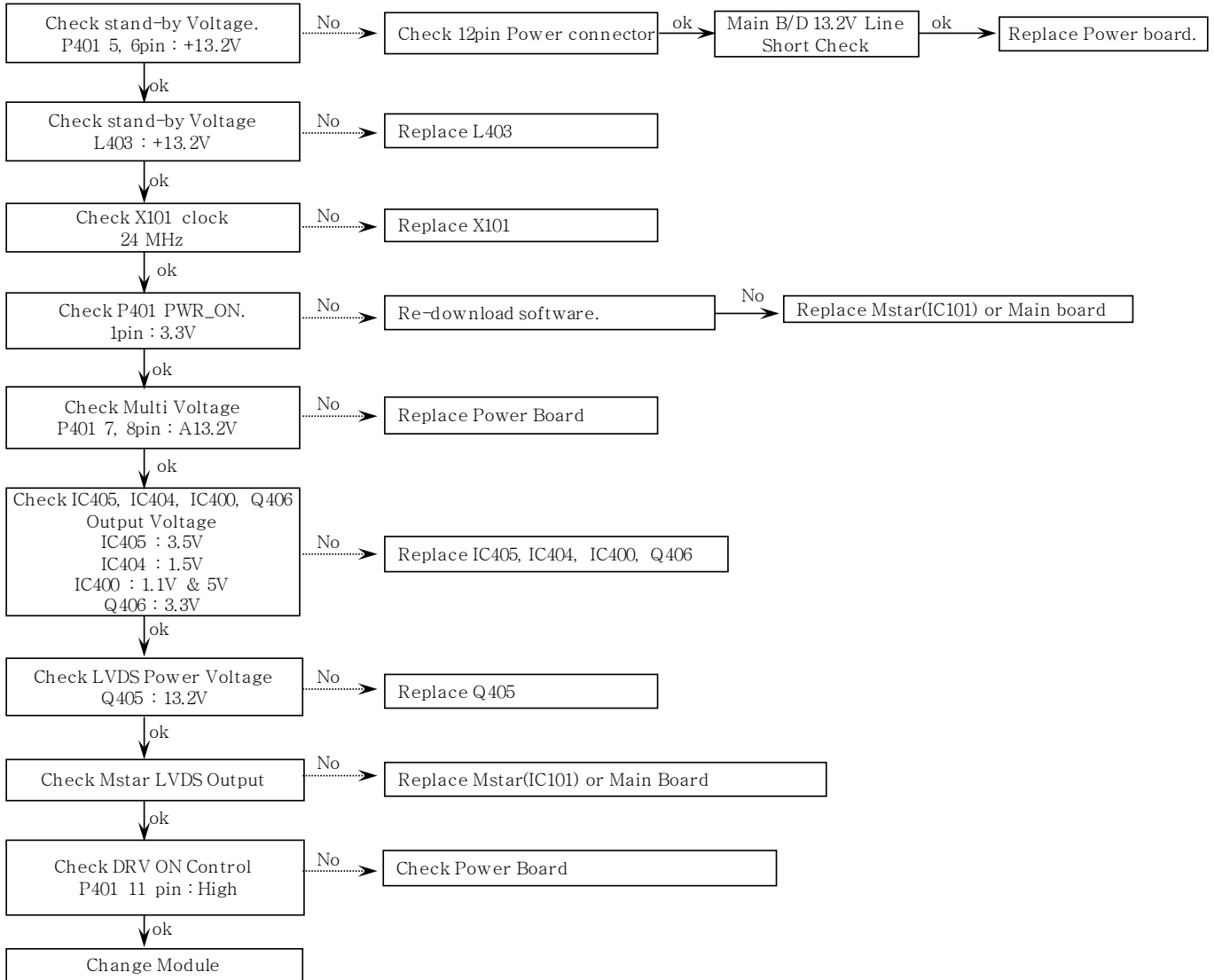

2. Digital/Analog TV Video

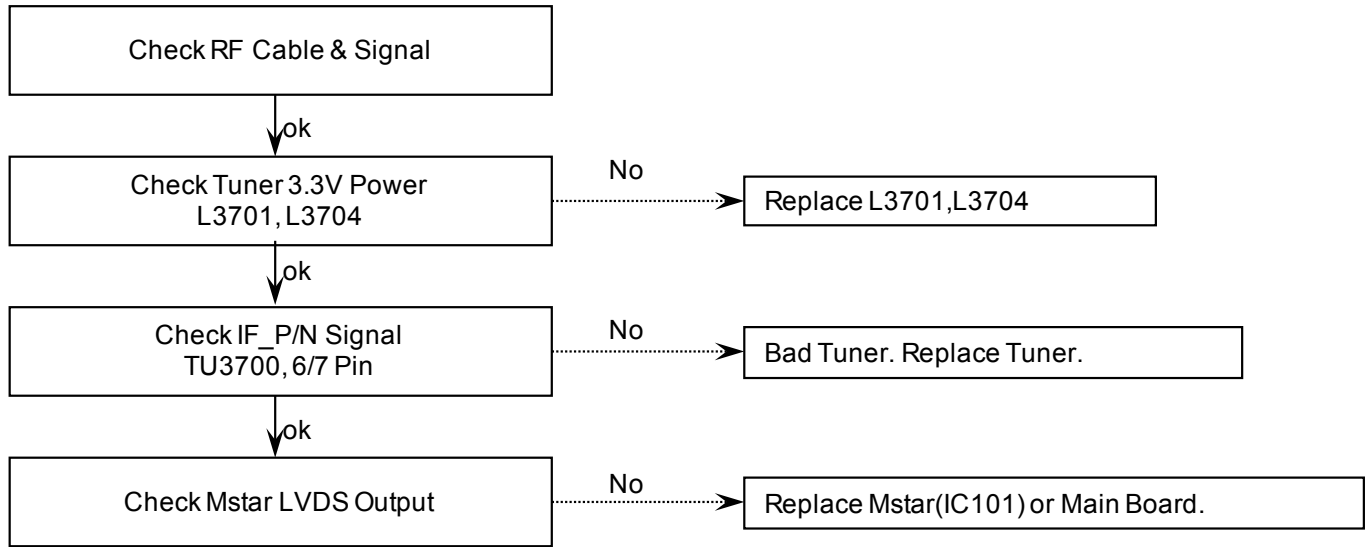

3. AV Video

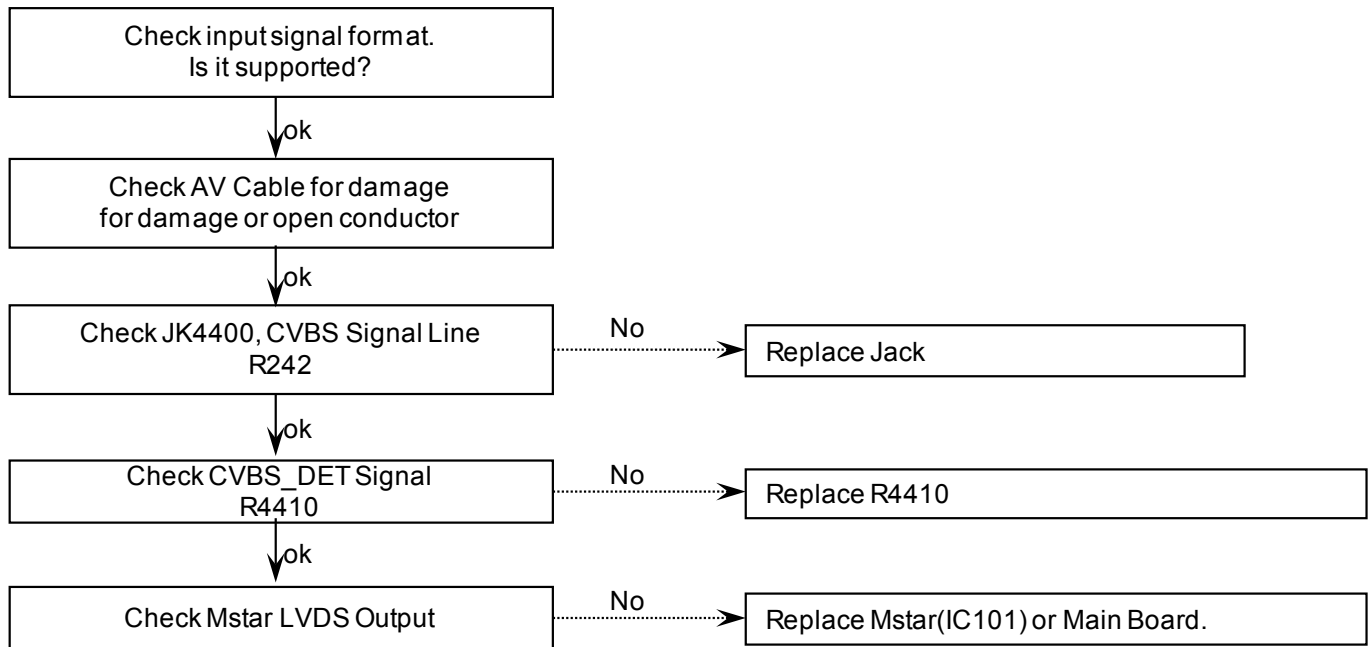

4. RGB Video

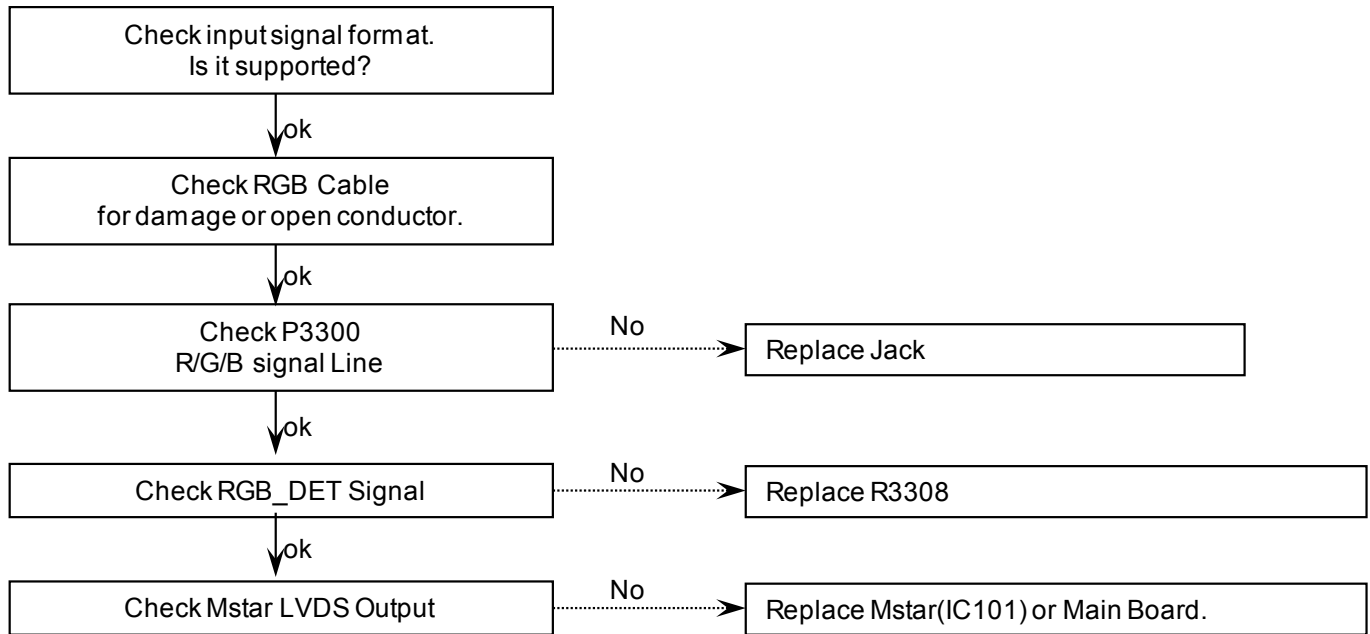

5. HDMI Video

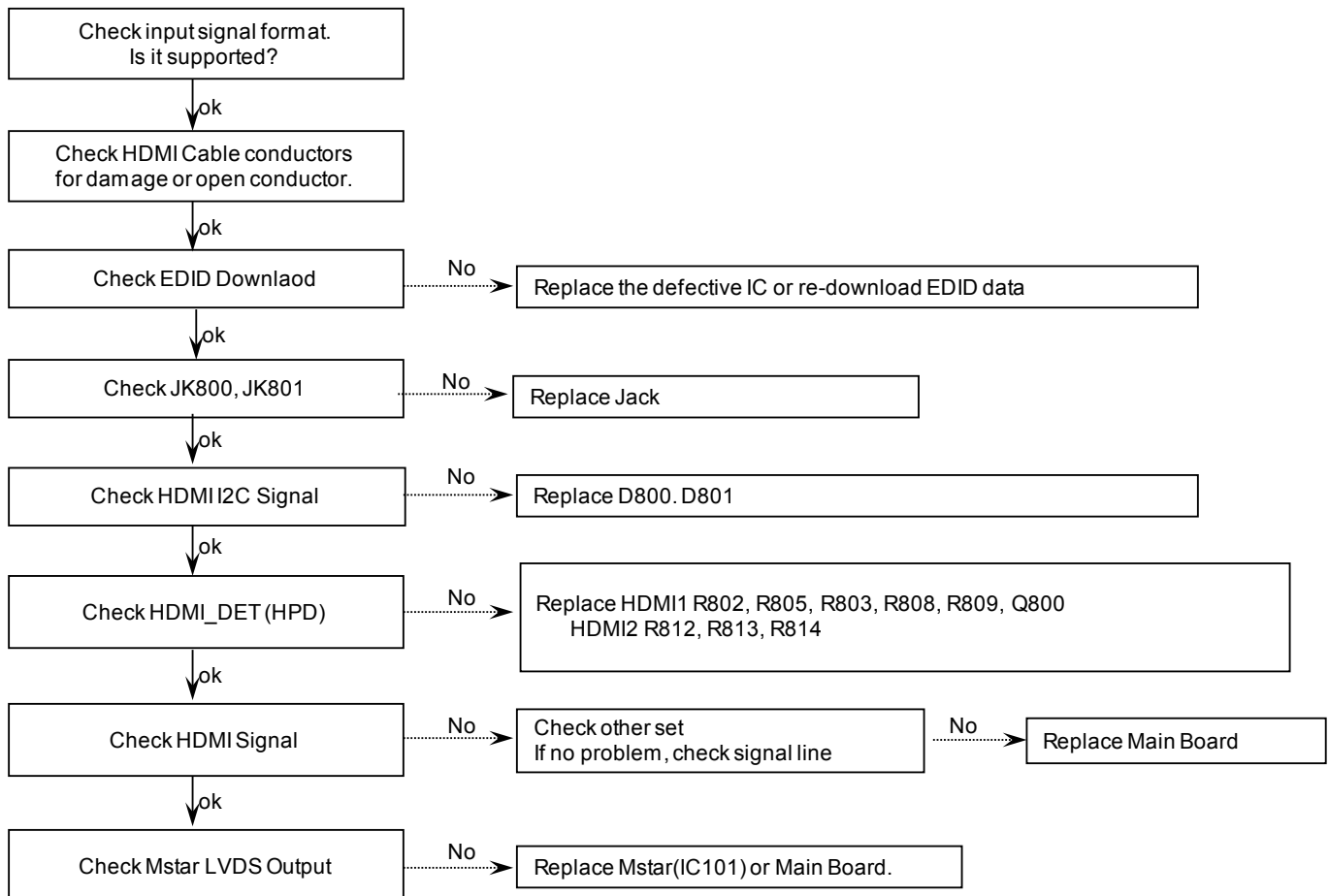

6. All Source Audio

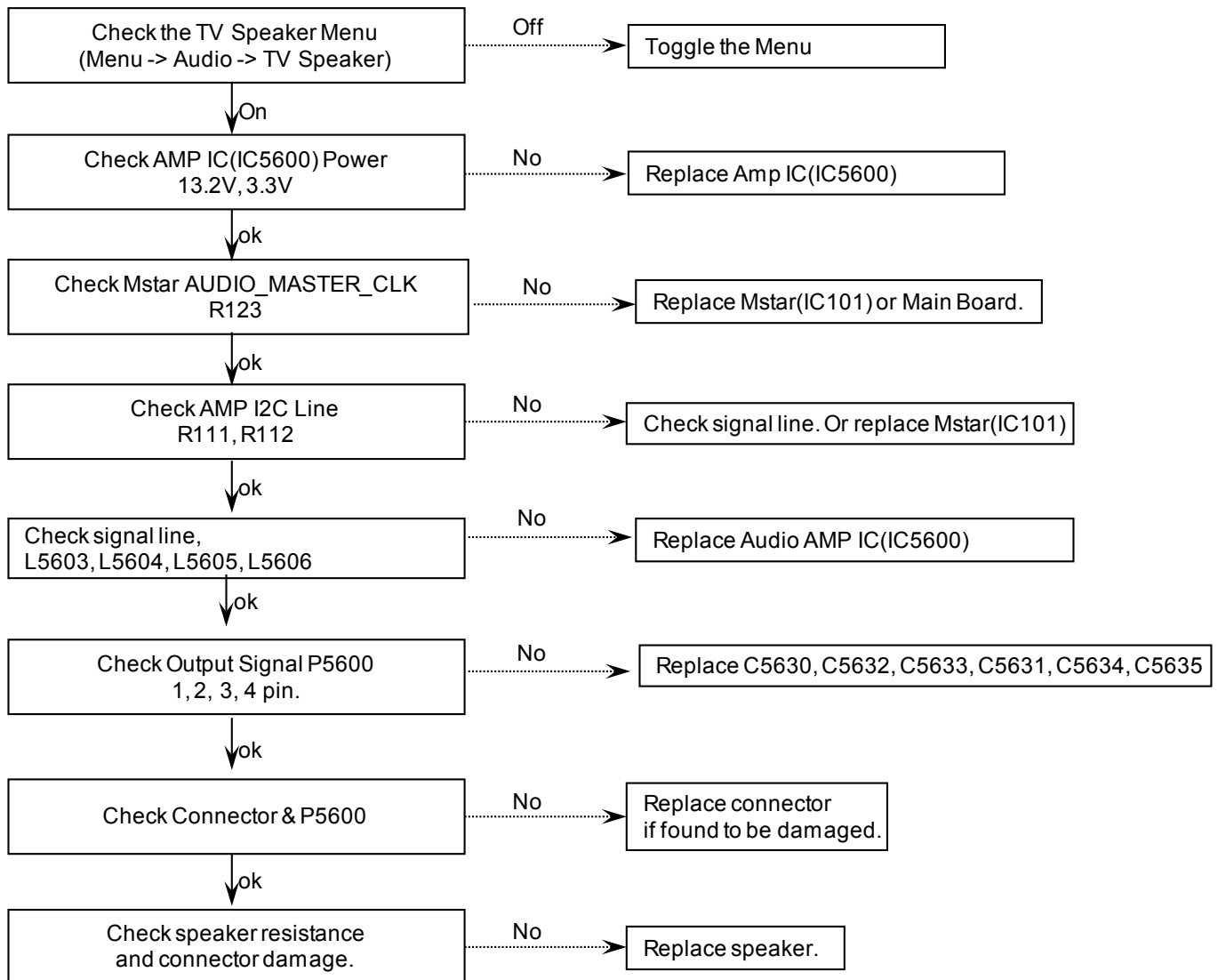

7. Digital/Analog TV Audio

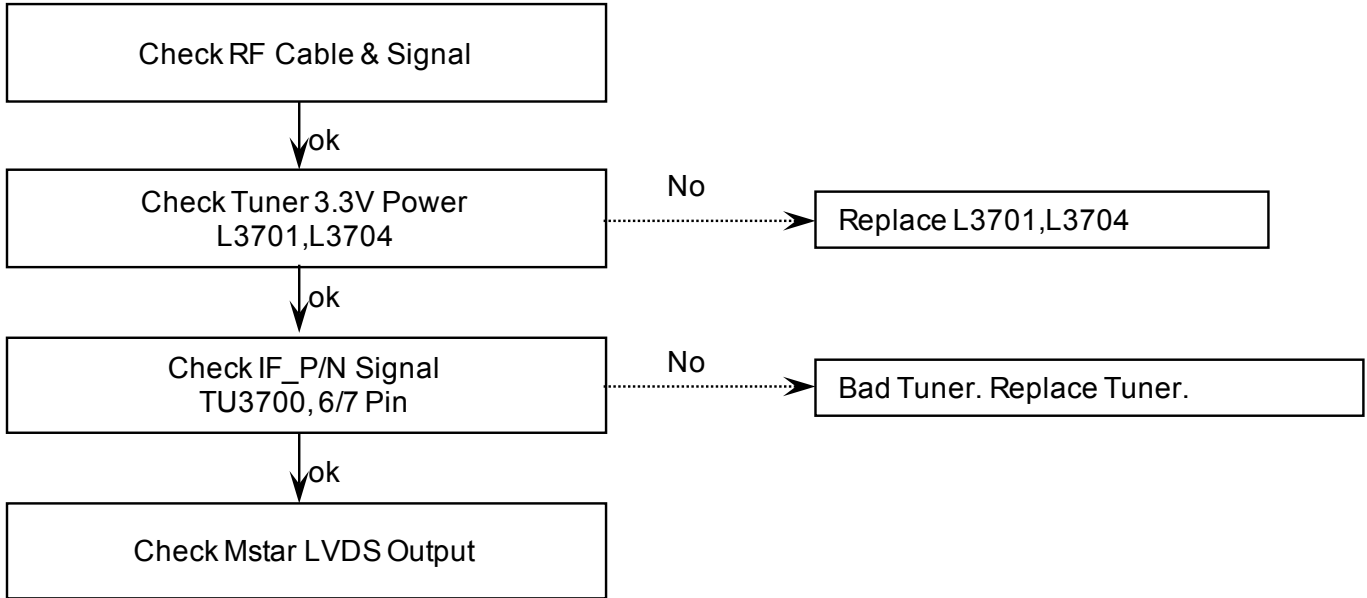

8. AV/RGB Audio

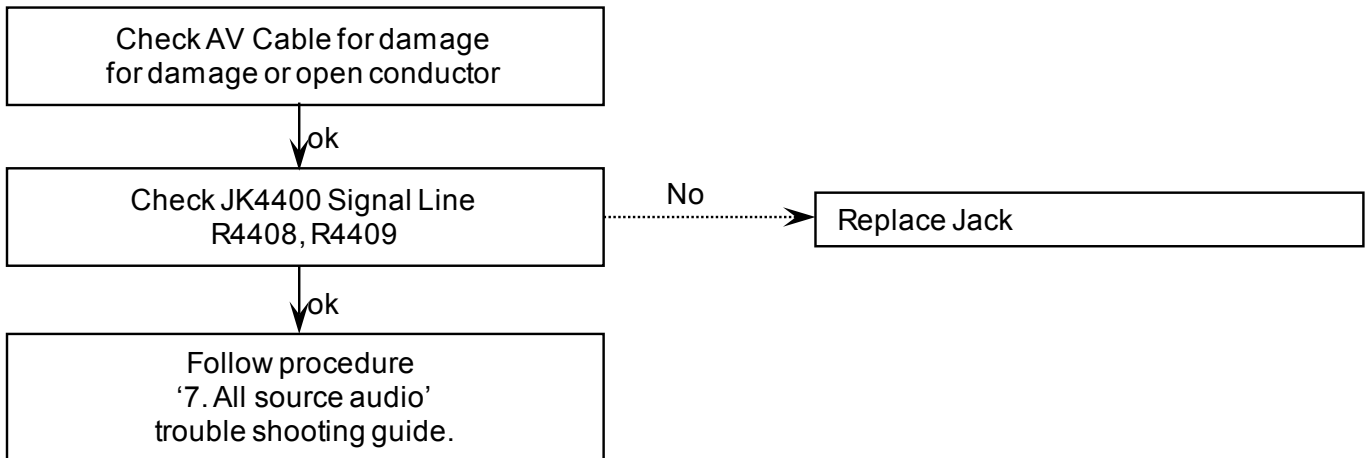

9. External Speaker Out

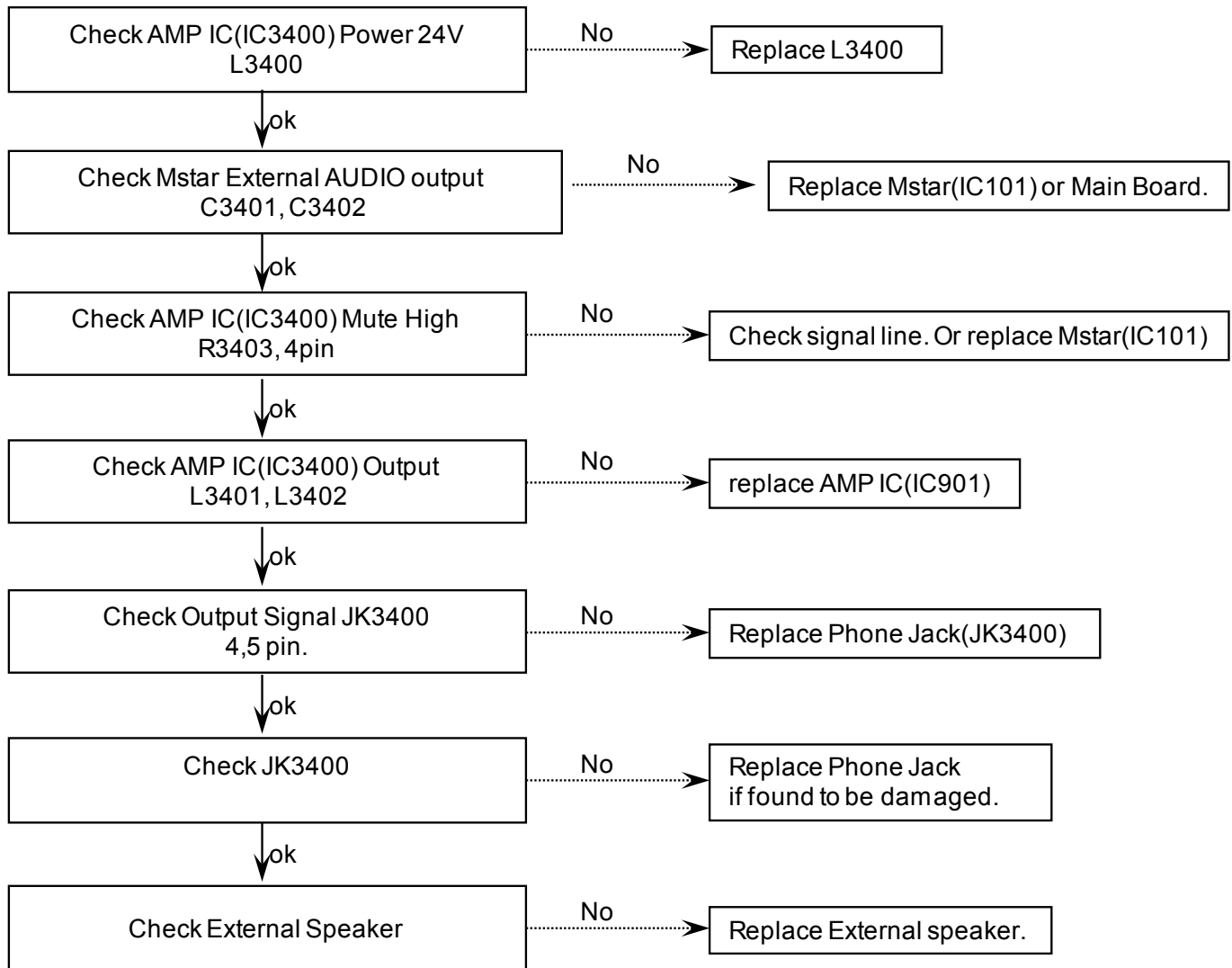

BLOCK DIAGRAM

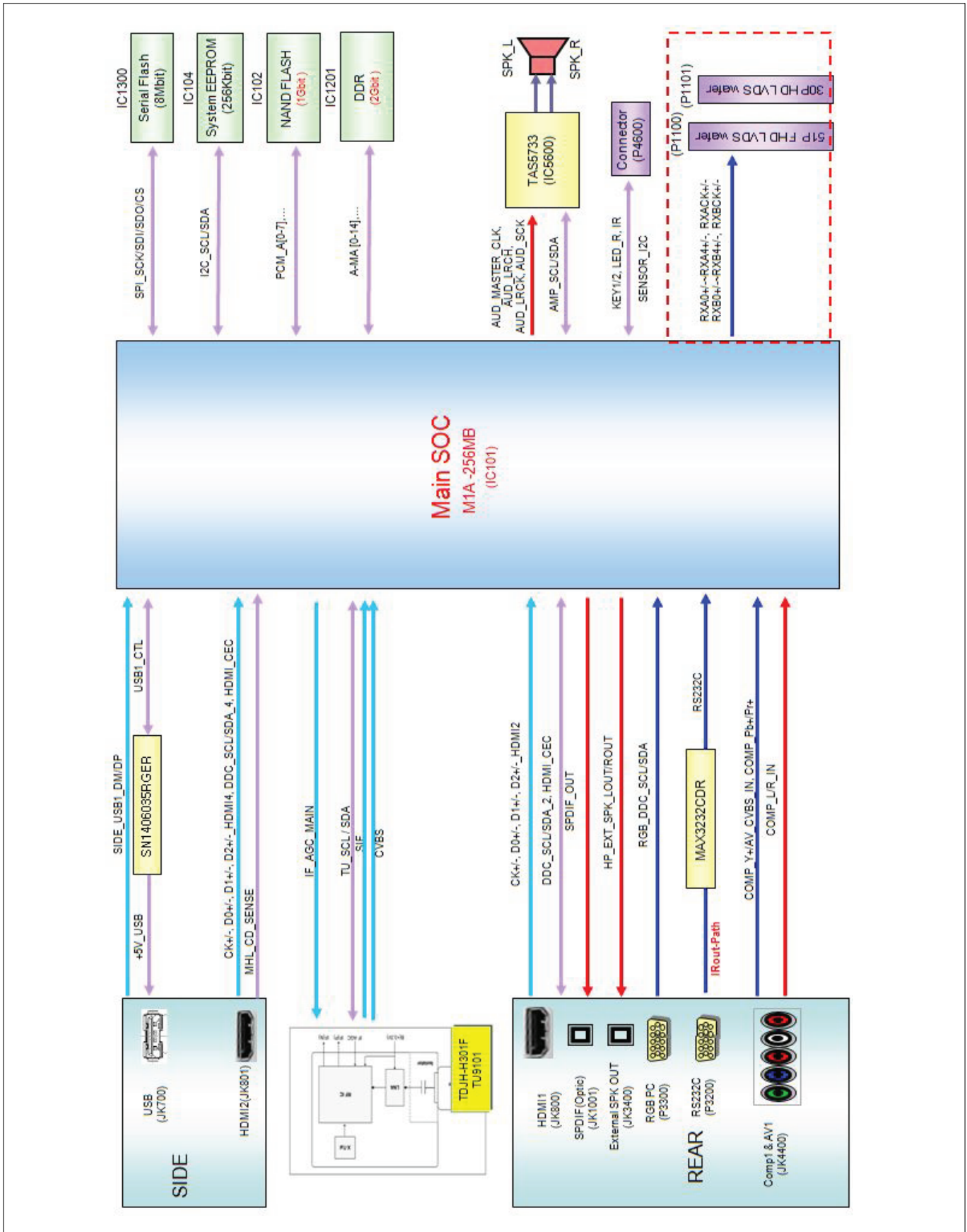

EXPLODED VIEW

IMPORTANT SAFETY NOTICE

Many electrical and mechanical parts in this chassis have special safety-related characteristics. These parts are identified by Δ in the EXPLODED VIEW. It is essential that these special safety parts should be replaced with the same components as recommended in this manual to prevent Shock, Fire, or other Hazards. Do not modify the original design without permission of manufacturer.

