



LG

Life's Good

North/Latin America
Europe/Africa
Asia/Oceania

Internal Use Only

<http://aic.lgservice.com>
<http://eic.lgservice.com>
<http://biz.lgservice.com>

LED TV

SERVICE MANUAL

CHASSIS : LA5ZC

MODEL : 49UF6430 49UF6430-UB
49UF6490 49UF6490-UB

CAUTION

BEFORE SERVICING THE CHASSIS,
READ THE SAFETY PRECAUTIONS IN THIS MANUAL.

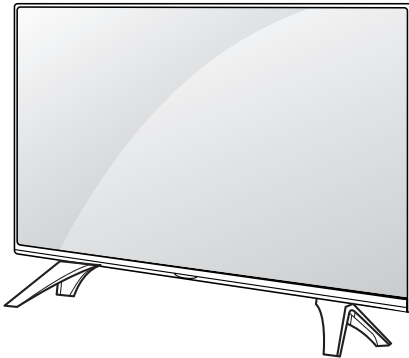

CONTENTS

CONTENTS	2
PRODUCT SAFETY	3
SERVICING PRECAUTIONS	4
SPECIFICATION	6
ADJUSTMENT INSTRUCTION	9
BLOCK DIAGRAM	21
EXPLODED VIEW	30
SCHEMATIC CIRCUIT DIAGRAM	APPENDIX
TROUBLESHOOTING GUIDE.....	APPENDIX

SAFETY PRECAUTIONS

IMPORTANT SAFETY NOTICE

Many electrical and mechanical parts in this chassis have special safety-related characteristics. These parts are identified by \triangle in the Schematic Diagram and Exploded View.

It is essential that these special safety parts should be replaced with the same components as recommended in this manual to prevent Shock, Fire, or other Hazards.

Do not modify the original design without permission of manufacturer.

General Guidance

An **isolation Transformer should always be used** during the servicing of a receiver whose chassis is not isolated from the AC power line. Use a transformer of adequate power rating as this protects the technician from accidents resulting in personal injury from electrical shocks.

It will also protect the receiver and its components from being damaged by accidental shorts of the circuitry that may be inadvertently introduced during the service operation.

If any fuse (or Fusible Resistor) in this TV receiver is blown, replace it with the specified.

When replacing a high wattage resistor (Oxide Metal Film Resistor, over 1 W), keep the resistor 10 mm away from PCB.

Keep wires away from high voltage or high temperature parts.

Before returning the receiver to the customer,

always perform an **AC leakage current check** on the exposed metallic parts of the cabinet, such as antennas, terminals, etc., to be sure the set is safe to operate without damage of electrical shock.

Leakage Current Cold Check(Antenna Cold Check)

With the instrument AC plug removed from AC source, connect an electrical jumper across the two AC plug prongs. Place the AC switch in the on position, connect one lead of ohm-meter to the AC plug prongs tied together and touch other ohm-meter lead in turn to each exposed metallic parts such as antenna terminals, phone jacks, etc.

If the exposed metallic part has a return path to the chassis, the measured resistance should be between 1 M Ω and 5.2 M Ω .

When the exposed metal has no return path to the chassis the reading must be infinite.

An other abnormality exists that must be corrected before the receiver is returned to the customer.

Leakage Current Hot Check (See below Figure)

Plug the AC cord directly into the AC outlet.

Do not use a line Isolation Transformer during this check.

Connect 1.5 K / 10 watt resistor in parallel with a 0.15 uF capacitor between a known good earth ground (Water Pipe, Conduit, etc.) and the exposed metallic parts.

Measure the AC voltage across the resistor using AC voltmeter with 1000 ohms/volt or more sensitivity.

Reverse plug the AC cord into the AC outlet and repeat AC voltage measurements for each exposed metallic part. Any voltage measured must not exceed 0.75 volt RMS which corresponds to 0.5 mA.

In case any measurement is out of the limits specified, there is possibility of shock hazard and the set must be checked and repaired before it is returned to the customer.

Leakage Current Hot Check circuit

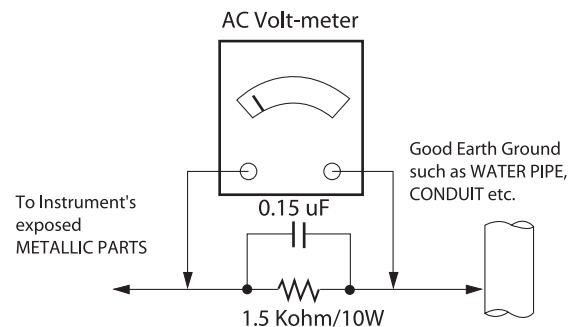

When 25A is impressed between Earth and 2nd Ground for 1 second, Resistance must be less than 0.1 Ω

*Base on Adjustment standard

SERVICING PRECAUTIONS

CAUTION: Before servicing receivers covered by this service manual and its supplements and addenda, read and follow the *SAFETY PRECAUTIONS* on page 3 of this publication.
NOTE: If unforeseen circumstances create conflict between the following servicing precautions and any of the safety precautions on page 3 of this publication, always follow the safety precautions. Remember: Safety First.

General Servicing Precautions

1. Always unplug the receiver AC power cord from the AC power source before;
 - a. Removing or reinstalling any component, circuit board module or any other receiver assembly.
 - b. Disconnecting or reconnecting any receiver electrical plug or other electrical connection.
 - c. Connecting a test substitute in parallel with an electrolytic capacitor in the receiver.
CAUTION: A wrong part substitution or incorrect polarity installation of electrolytic capacitors may result in an explosion hazard.
2. Test high voltage only by measuring it with an appropriate high voltage meter or other voltage measuring device (DVM, FETVOM, etc) equipped with a suitable high voltage probe. Do not test high voltage by "drawing an arc".
3. Do not spray chemicals on or near this receiver or any of its assemblies.
4. Unless specified otherwise in this service manual, clean electrical contacts only by applying the following mixture to the contacts with a pipe cleaner, cotton-tipped stick or comparable non-abrasive applicator; 10 % (by volume) Acetone and 90 % (by volume) isopropyl alcohol (90 % - 99 % strength)
CAUTION: This is a flammable mixture.
Unless specified otherwise in this service manual, lubrication of contacts is not required.
5. Do not defeat any plug/socket B+ voltage interlocks with which receivers covered by this service manual might be equipped.
6. Do not apply AC power to this instrument and/or any of its electrical assemblies unless all solid-state device heat sinks are correctly installed.
7. Always connect the test receiver ground lead to the receiver chassis ground before connecting the test receiver positive lead.
Always remove the test receiver ground lead last.
8. Use with this receiver only the test fixtures specified in this service manual.
CAUTION: Do not connect the test fixture ground strap to any heat sink in this receiver.

Electrostatically Sensitive (ES) Devices

Some semiconductor (solid-state) devices can be damaged easily by static electricity. Such components commonly are called Electrostatically Sensitive (ES) Devices. Examples of typical ES devices are integrated circuits and some field-effect transistors and semiconductor "chip" components. The following techniques should be used to help reduce the incidence of component damage caused by static by static electricity.

1. Immediately before handling any semiconductor component or semiconductor-equipped assembly, drain off any electrostatic charge on your body by touching a known earth ground. Alternatively, obtain and wear a commercially available discharging wrist strap device, which should be removed to prevent potential shock reasons prior to applying power to the unit under test.

2. After removing an electrical assembly equipped with ES devices, place the assembly on a conductive surface such as aluminum foil, to prevent electrostatic charge buildup or exposure of the assembly.
3. Use only a grounded-tip soldering iron to solder or unsolder ES devices.
4. Use only an anti-static type solder removal device. Some solder removal devices not classified as "anti-static" can generate electrical charges sufficient to damage ES devices.
5. Do not use freon-propelled chemicals. These can generate electrical charges sufficient to damage ES devices.
6. Do not remove a replacement ES device from its protective package until immediately before you are ready to install it. (Most replacement ES devices are packaged with leads electrically shorted together by conductive foam, aluminum foil or comparable conductive material).
7. Immediately before removing the protective material from the leads of a replacement ES device, touch the protective material to the chassis or circuit assembly into which the device will be installed.
CAUTION: Be sure no power is applied to the chassis or circuit, and observe all other safety precautions.
8. Minimize bodily motions when handling unpackaged replacement ES devices. (Otherwise harmless motion such as the brushing together of your clothes fabric or the lifting of your foot from a carpeted floor can generate static electricity sufficient to damage an ES device.)

General Soldering Guidelines

1. Use a grounded-tip, low-wattage soldering iron and appropriate tip size and shape that will maintain tip temperature within the range or 500 °F to 600 °F.
2. Use an appropriate gauge of RMA resin-core solder composed of 60 parts tin/40 parts lead.
3. Keep the soldering iron tip clean and well tinned.
4. Thoroughly clean the surfaces to be soldered. Use a small wire-bristle (0.5 inch, or 1.25 cm) brush with a metal handle. Do not use freon-propelled spray-on cleaners.
5. Use the following unsoldering technique
 - a. Allow the soldering iron tip to reach normal temperature. (500 °F to 600 °F)
 - b. Heat the component lead until the solder melts.
 - c. Quickly draw the melted solder with an anti-static, suction-type solder removal device or with solder braid.
CAUTION: Work quickly to avoid overheating the circuit board printed foil.
6. Use the following soldering technique.
 - a. Allow the soldering iron tip to reach a normal temperature (500 °F to 600 °F)
 - b. First, hold the soldering iron tip and solder the strand against the component lead until the solder melts.
 - c. Quickly move the soldering iron tip to the junction of the component lead and the printed circuit foil, and hold it there only until the solder flows onto and around both the component lead and the foil.
CAUTION: Work quickly to avoid overheating the circuit board printed foil.
 - d. Closely inspect the solder area and remove any excess or splashed solder with a small wire-bristle brush.

IC Remove/Replacement

Some chassis circuit boards have slotted holes (oblong) through which the IC leads are inserted and then bent flat against the circuit foil. When holes are the slotted type, the following technique should be used to remove and replace the IC. When working with boards using the familiar round hole, use the standard technique as outlined in paragraphs 5 and 6 above.

Removal

1. Desolder and straighten each IC lead in one operation by gently prying up on the lead with the soldering iron tip as the solder melts.
2. Draw away the melted solder with an anti-static suction-type solder removal device (or with solder braid) before removing the IC.

Replacement

1. Carefully insert the replacement IC in the circuit board.
2. Carefully bend each IC lead against the circuit foil pad and solder it.
3. Clean the soldered areas with a small wire-bristle brush. (It is not necessary to reapply acrylic coating to the areas).

"Small-Signal" Discrete Transistor Removal/Replacement

1. Remove the defective transistor by clipping its leads as close as possible to the component body.
2. Bend into a "U" shape the end of each of three leads remaining on the circuit board.
3. Bend into a "U" shape the replacement transistor leads.
4. Connect the replacement transistor leads to the corresponding leads extending from the circuit board and crimp the "U" with long nose pliers to insure metal to metal contact then solder each connection.

Power Output, Transistor Device

Removal/Replacement

1. Heat and remove all solder from around the transistor leads.
2. Remove the heat sink mounting screw (if so equipped).
3. Carefully remove the transistor from the heat sink of the circuit board.
4. Insert new transistor in the circuit board.
5. Solder each transistor lead, and clip off excess lead.
6. Replace heat sink.

Diode Removal/Replacement

1. Remove defective diode by clipping its leads as close as possible to diode body.
2. Bend the two remaining leads perpendicular y to the circuit board.
3. Observing diode polarity, wrap each lead of the new diode around the corresponding lead on the circuit board.
4. Securely crimp each connection and solder it.
5. Inspect (on the circuit board copper side) the solder joints of the two "original" leads. If they are not shiny, reheat them and if necessary, apply additional solder.

Fuse and Conventional Resistor

Removal/Replacement

1. Clip each fuse or resistor lead at top of the circuit board hollow stake.
2. Securely crimp the leads of replacement component around notch at stake top.

3. Solder the connections.

CAUTION: Maintain original spacing between the replaced component and adjacent components and the circuit board to prevent excessive component temperatures.

Circuit Board Foil Repair

Excessive heat applied to the copper foil of any printed circuit board will weaken the adhesive that bonds the foil to the circuit board causing the foil to separate from or "lift-off" the board. The following guidelines and procedures should be followed whenever this condition is encountered.

At IC Connections

To repair a defective copper pattern at IC connections use the following procedure to install a jumper wire on the copper pattern side of the circuit board. (Use this technique only on IC connections).

1. Carefully remove the damaged copper pattern with a sharp knife. (Remove only as much copper as absolutely necessary).
2. Carefully scratch away the solder resist and acrylic coating (if used) from the end of the remaining copper pattern.
3. Bend a small "U" in one end of a small gauge jumper wire and carefully crimp it around the IC pin. Solder the IC connection.
4. Route the jumper wire along the path of the out-away copper pattern and let it overlap the previously scraped end of the good copper pattern. Solder the overlapped area and clip off any excess jumper wire.

At Other Connections

Use the following technique to repair the defective copper pattern at connections other than IC Pins. This technique involves the installation of a jumper wire on the component side of the circuit board.

1. Remove the defective copper pattern with a sharp knife. Remove at least 1/4 inch of copper, to ensure that a hazardous condition will not exist if the jumper wire opens.
2. Trace along the copper pattern from both sides of the pattern break and locate the nearest component that is directly connected to the affected copper pattern.
3. Connect insulated 20-gauge jumper wire from the lead of the nearest component on one side of the pattern break to the lead of the nearest component on the other side. Carefully crimp and solder the connections.
CAUTION: Be sure the insulated jumper wire is dressed so the it does not touch components or sharp edges.

SPECIFICATION

NOTE : Specifications and others are subject to change without notice for improvement.

1. Application range

This spec sheet is applied to the LED TV used LA5ZC chassis

2. Test condition

Each part is tested as below without special notice.

- (1) Temperature : 25 °C ± 5 °C(77±9°F), CST : 40 °C±5 °C
- (2) Relative Humidity: 65 % ± 10 %
- (3) Power Voltage
Standard input voltage (100~240V@ 50/60Hz)
* Standard Voltage of each products is marked by models.
- (4) Specification and performance of each parts are followed each drawing and specification by part number in accordance with BOM.
- (5) The receiver must be operated for about 20 minutes prior to the adjustment.

3. Test method

- (1) Performance: LGE TV test method followed
- (2) Demanded other specification
 - Safety : UL, CSA, CE, IEC specification
 - EMC : FCC, ICES, CE, IEC specification
 - Wireless : Wireless HD Specification (Option)

4. Model Specification

No	Item	Specification	Remark
1	Market	North America	
2	Broadcasting system	ATSC / NTSC-M, 64 & 256 QAM	
3	Available Channel	1) VHF : 2~13	
		2) UHF : 14~69	
		3) DTV : 2-69	
		4) CATV : 1 ~ 135	
		5) CADTV : 1 ~ 135	
4	Receiving system	Digital : ATSC, 64 & 256 QAM Analog : NTSC-M	
5	Video Input	NTSC-M	Rear RCA & Gender
6	Component Input	Y/Cb/Cr, Y/ Pb/Pr	Rear RCA & Gender
7	HDMI Input	HDMI 1 DTV format, Support HDCP2.2/ PC (HDMI version 1.4/2.0)	Side
		HDMI 2 DTV format, Support HDCP2.2/ PC (HDMI version 1.4/2.0)	Side, Support ARC only HDMI2
		HDMI 3 DTV format, Support HDCP2.2/ PC (HDMI version 1.4)	Side
8	Audio Input	Component / AV Audio	L/R Input ; Rear Component and av use same jack ; Rear
9	SPDIF out(1EA)	Optical Audio out	Rear (1EA),
10	USB Input(3EA)	EMF, DivX HD, For SVC (download)	Side JPEG, MP3, DivX HD Support USB3.0 only USB1

5. External input format

5.1. 2D Mode

5.1.1. Component input(Y, CB/PB, CR/PR)

No	Resolution	H-freq(kHz)	V-freq.(Hz)	Pixel clock(MHz)	Proposed
1	720*480	15.73	60	13.5135	SDTV ,DVD 480I
2	720*480	15.73	59.94	13.5	SDTV ,DVD 480I
3	720*480	31.50	60	27.027	SDTV 480P
4	720*480	31.47	59.94	27.0	SDTV 480P
5	1280*720	45.00	60.00	74.25	HDTV 720P
6	1280*720	44.96	59.94	74.176	HDTV 720P
7	1920*1080	33.75	60.00	74.25	HDTV 1080I
8	1920*1080	33.72	59.94	74.176	HDTV 1080I
9	1920*1080	67.500	60	148.50	HDTV 1080P
10	1920*1080	67.432	59.94	148.352	HDTV 1080P

5.1.2. HDMI Input (PC/DTV)

No.	Resolution	H-freq(kHz)	V-freq.(kHz)	Pixel clock(MHz)	Proposed	
	HDMI-PC					DDC
1	640*350	31.46	70.09	25.17	EGA	X
2	720*400	31.46	70.08	28.32	DOS	O
3	640*480	31.46	59.94	25.17	VESA(VGA)	O
4	800*600	37.87	60.31	40.00	VESA(SVGA)	O
5	1024*768	48.36	60.00	65.00	VESA(XGA)	O
6	1152*864	54.34	60.05	80.00	VESA	O
7	1280*1024	63.98	60.02	108.00	VESA (SXGA)	O
8	1360*768	47.71	60.01	85.50	VESA (WXGA)	O
9	1920*1080	67.5	60	148.5	WUXGA(Reduced Blanking)	O
10	3840*2160	67.5	30	297.00	Only UD Model	O
11	3840*2160	56.25	25.00	297.00	Only UD Model	O
12	3840*2160	54	24	297.00	Only UD Model	O
13	4096*2160	53.95	23.97	297	Only UD Model	O
14	4096*2160	54	24	297	Only UD Model	O

HDMI-DTV					
1	640 * 480	31.46	59.94	25.125	SDTV 480P
2	640 * 480	31.5	60	25.125	SDTV 480P
3	720 * 480	31.5	60	27.027	SDTV 480P
4	720 * 480	31.47	59.94	27.00	SDTV 480P
5	1280*720	45.00	60.00	74.25	HDTV 720P
6	1280*720	44.96	59.94	74.176	HDTV 720P
7	1920*1080	33.75	60.00	74.25	HDTV 1080I
8	1920*1080	33.72	59.94	74.176	HDTV 1080I
9	1920*1080	67.50	60	148.50	HDTV 1080P
10	1920*1080	67.432	59.94	148.35	HDTV 1080P
11	1920*1080	27.000	24.000	74.25	HDTV 1080P
12	1920*1080	26.97	23.976	74.176	HDTV 1080P
13	1920*1080	33.75	30.000	74.25	HDTV 1080P
14	1920*1080	33.71	29.97	74.176	HDTV 1080P
15	3840*2160	67.5	30.00	297.00	UDTV 2160P
16	3840*2160	61.43	29.97	296.703	UDTV 2160P
17	3840*2160	56.25	25.00	297.00	UDTV 2160P
18	3840*2160	54.0	24.00	297.00	UDTV 2160P
19	3840*2160	53.95	23.98	296.703	UDTV 2160P
20	3840*2160	135	59.94	594	UDTV 2160P(HDMI 1,2 only)
21	3840*2160	135	60	594	UDTV 2160P(HDMI 1,2 only)
22	4096*2160	53.95	23.98	296.703	UDTV 2160P
23	4096*2160	54	24	297	UDTV 2160P
24	4096*2160	56.25	25	297	UDTV 2160P
25	4096*2160	61.43	29.97	296.703	UDTV 2160P
26	4096*2160	67.5	30	297	UDTV 2160P
27	4096*2160	135	59.94	594	UDTV 2160P(HDMI 1,2 only)
28	4096*2160	135	60	594	UDTV 2160P(HDMI 1,2only)

ADJUSTMENT INSTRUCTION

1. Application Range

This spec. sheet applies to LA5ZC Chassis applied LED TV all models manufactured in TV factory

2. Specification.

- (1) Because this is not a hot chassis, it is not necessary to use an isolation transformer. However, the use of isolation transformer will help protect test instrument
- (2) Adjustment must be done in the correct order.
- (3) The adjustment must be performed in the circumstance of 25 ±5°C of temperature and 65±10% of relative humidity if there is no specific designation
- (4) The input voltage of the receiver must keep 100~240V, 50/60Hz
- (5) The receiver must be operated for about 5 minutes prior to the adjustment when module is in the circumstance of over 15°C

- In case of keeping module is in the circumstance of 0°C, it should be placed in the circumstance of above 15°C for 2 hours
- In case of keeping module is in the circumstance of below -20°C, it should be placed in the circumstance of above 15°C for 3 hours

* Caution) When still image is displayed for a period of 20 minutes or longer (especially where W/B scale is strong. Digital pattern 13ch and/or Cross hatch pattern 09ch), there can some afterimage in the black level area.

3. Adjustment items

3.1. Main PCB check process

- MAC Address Download
- ADC adjustment : 480i Comp1, 1920*1080 Comp1
- EDID/DDC download

Above adjustment items can be also performed in Final Assembly if needed. Both Board-level and Final assembly adjustment items can be check using In-Start Menu 1.ADJUST CHECK.

3.2. Final assembly adjustment

- White Balance adjustment
- RS-232C functionality check
- PING Test
- Factory Option setting per destination
- Ship-out mode setting (In-Stop)

3.3. Etc.

- Ship-out mode
- Service Option Default
- USB Download(S/W Update, Option, Service only)
- ISP Download (Option)

4. Automatic Adjustment

4.1. ADC Adjustment

ADC adjustment is needed to find the optimum black level and gain in Analog-to-Digital device and to compensate RGB deviation.

4.1.1. Equipment & Condition

- (1) USB to RS-232C Jig
- (2) MSPG-925 Series Pattern Generator(MSPG-925FA, pattern -65)
 - Resolution : 480i Comp1
1080P Comp1
 - Pattern : Horizontal 100% Color Bar Pattern
 - Pattern level : 0.7±0.1 Vp-p
 - Image



4.1.2. Adjustment method

- Using USB, adjust items listed in 3.1 in the other shown in "4.1.3.3"

4.1.3. 3 Adj. protocol

Protocol	Command	Set ACK
Enter adj. mode	aa 00 00	a 00 OK00x
Source change	xb 00 40 xb 00 60	b 00 OK04x (Adjust 480i, 1080p Comp1) b 00 OK06x (Adjust 1920*1080 RGB)
Begin adj.	ad 00 10	
Return adj. result		OKx (Case of Success) NGx (Case of Fail)
Read adj. data	(main) ad 00 20 (sub) ad 00 21	(main) 00000000000000000000000007c007b-006dx (Sub) 00000007000000000000000007c00830077x
Confirm adj.	ad 00 99	NG 03 00x (Fail) NG 03 01x (Fail) NG 03 02x (Fail) OK 03 03x (Success)
End adj.	ad 00 90	a 00 OK90x

Ref.) ADC Adj. RS232C Protocol_Ver1.0

Adj. order

- aa 00 00 [Enter ADC adj. mode]
- xb 00 04 [Change input source to Component1(480i&1080p)]
- ad 00 10 [Adjust 480i&1080p Comp1]
- xb 00 06 [Change input source to RGB(1024*768)]
- ad 00 10 [Adjust 1920*1080 RGB]- aa 00 90 End adj.

4.2. MAC address, ESN, Widevine, HDCP2.0 key D/L

4.2.1. Equipment & Condition

- (1) Play file: keydownload.exe

4.2.2. Communication Port connection

- (1) Key Write: Com 1,2,3,4 and 115200 (Baudrate)
- (2) Barcode: Com 1,2,3,4 and 9600 (Baudrate)

4.2.3. Download process

- (1) Select the download items.
- (2) Mode check: Online Only
- (3) Check the test process : DETECT -> MAC -> Widevine
- (4) Play: START
- (5) Check of result: Ready, Test, OK or NG

4.2.4. Communication Port connection

- (1) Connect: PCBA Jig -> RS-232C Port == PC -> RS-232C Port

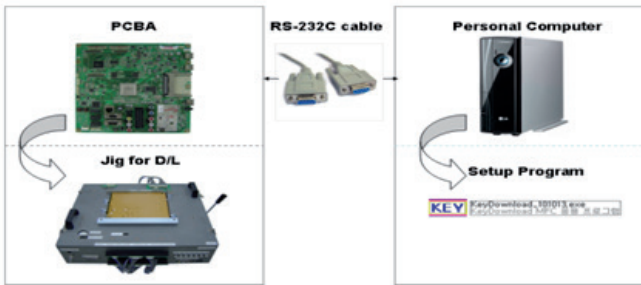

4.2.5. Download

- (1) AJ/JA Models (15Y LCD TV + MAC + Widevine + ESN + HDCP2.0)

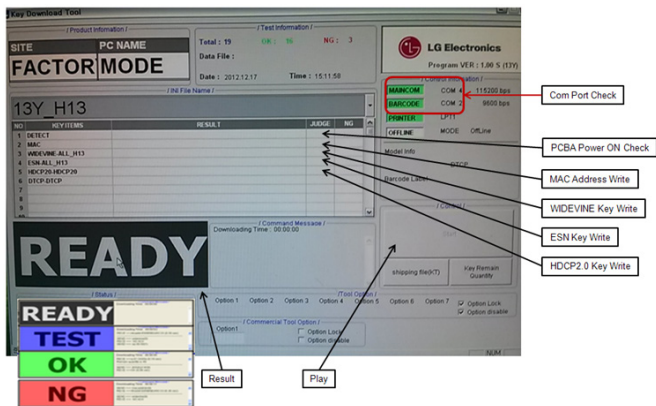

4.3. LAN Inspection

4.3.1. Equipment & Condition

- Each other connection to LAN Port of IP Hub and Jig

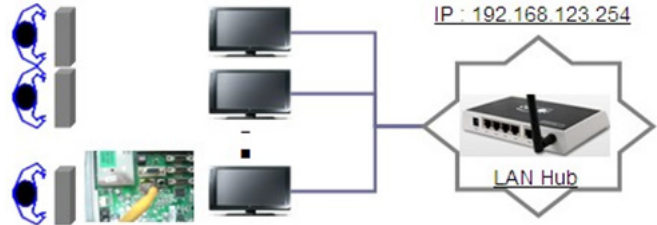

4.3.2. LAN inspection solution

- LAN Port connection with PCB
- Network setting at MENU Mode of TV
- Setting automatic IP
- Setting state confirmation
- If automatic setting is finished, you confirm IP and MAC Address.

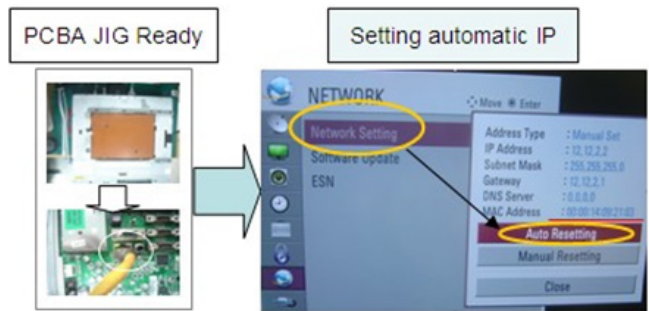

4.3.3. LAN PORT INSPECTION (PING TEST)

Connect: SET -> LAN Port == PC -> LAN Port



- (1) Play the LAN Port Test PROGRAM.
- (2) Input IP set up for an inspection to Test Program.
*IP Number : 12.12.2.2.

4.3.4. LAN PORT inspection (PING TEST)

- (1) Play the LAN Port Test Program.
- (2) connect each other LAN Port Jack.
- (3) Play Test (F9) button and confirm OK Message.
- (4) remove LAN CABLE



4.4. Model name & Serial number Download

4.4.1. Model name & Serial number D/L

- Press "Power on" key of service remote.(Baud rate : 115200 bps)
- Connect RS-232C Signal to USB Cable to USB.
- Write Serial number by use USB port.
- Must check the serial number at Instart menu.

Method & Notice

- A. Serial number D/L is using of scan equipment.
- B. Setting of scan equipment operated by Manufacturing Technology Group.
- C. Serial number D/L must be conformed when it is produced in production line, because serial number D/L is mandatory by D-book 4.0

* Manual Download (Model Name and Serial Number)

If the TV set is downloaded By OTA or Service man, sometimes model name or serial number is initialized. (not always)

It is impossible to download by bar code scan, so It need Manual download.

- a. Press the 'INSTART' key of ADJ remote controller.
- b. Go to the menu '7. Model Number D/L' like below photo.
- c. Input the Factory model name or Serial number like below photo.

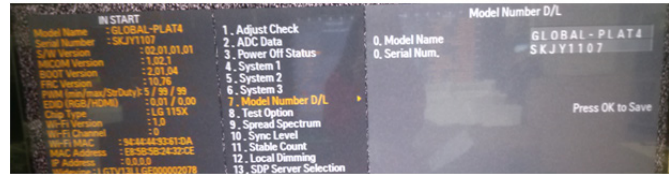

- d. Check the model name INSTART menu -> Factory name displayed
- e. Check the Diagnostics (DTV country only) -> Buyer model displayed

4.5. WIFI MAC ADDRESS CHECK

4.5.1. Using RS232 Command

	Command	Set ACK
Transmission	[A][J][Set Id][20][Cr]	[O][K][x] or [N][G]

- Check the menu on in-start

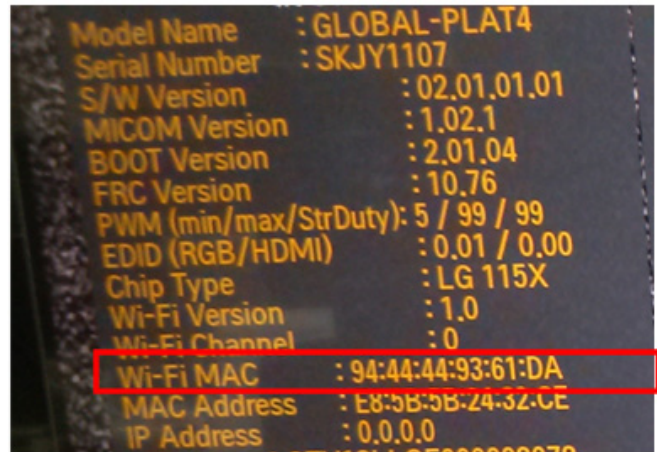

5. Manual Adjustment

5.1. ADC adjustment is not needed because of OTP (Auto ADC adjustment)

5.2. EDID

(The Extended Display Identification Data) / DDC (Display Data Channel) download

5.2.1. Overview

It is a VESA regulation. A PC or a MNT will display an optimal resolution through information sharing without any necessity of user input. It is a realization of "Plug and Play".

5.2.2. Equipment

- Since embedded EDID data is used, EDID download JIG, HDMI cable and D-sub cable are not need.
- Adjust remocon

5.2.3. Download method

(1) Press Adj. key on the Adjust remocon, then select "12.EDID D/L".

By pressing Enter key, enter EDID D/L menu



(2) Select [Start] button by pressing Enter key, HDMI1 / HDMI2 / HDMI3 / HDMI4 are Writing and display OK or NG.

5.2.4. EDID DATA

- Reference
 - HDMI1 ~ HDMI3
 - HDMI1 ~ HDMI4
 - In the data of EDID, bellows may be different by Input mode

	0	1	2	3	4	5	6	7	8	9	A	B	C	D	E	F
0x00	00	FF	FF	FF	FF	FF	FF	00	1E	6D	ⓐ		ⓑ			
0x01	ⓐ	01	03	80	A0	5A	78	0A	EE	91	A3	54	4C	99	26	
0x02	0F	50	54	A1	8	00	31	40	45	40	61	40	71	40	81	80
0x03	01	01	01	01	01	01	02	3A	80	18	71	38	2D	40	58	2C
0x04	45	00	40	84	63	00	00	1E	66	21	50	B0	51	00	1B	30
0x05	40	70	36	00	40	84	63	00	00	1E	00	00	00	FD	00	3A
0x06	3E	1E	53	10	00	0A	20	20	20	20	20	20	ⓐ			
0x07	ⓐ														01	ⓐ1
0x00	02	03	3A	F1	4E	10	9F	04	13	05	14	03	02	12	20	21
0x01	22	15	01	29	3D	06	C0	15	07	50	ⓐ					
0x02	ⓐ															
0x03	ⓐ		10	28	10	E3	05	03	01	02	3A	80	18	71	38	
0x04	2D	40	58	2C	45	00	40	84	63	00	00	1E	01	1D	80	18
0x05	71	1C	16	20	58	2C	25	00	40	84	63	00	00	9E	01	1D
0x06	00	72	51	D0	1E	20	6E	28	55	00	40	84	63	00	00	1E
0x07	00	00	00	00	00	00	00	00	00	00	00	00	00	00	00	ⓐ2

- ⓐ Product ID
- ⓑ Serial No: Controlled on production line.
- ⓒ Month, Year: Controlled on production line:
 - ex) Monthly : '01' -> '01'
 - Year : '2015' -> '19'
- ⓓ Model Name(Hex): LGTV
- ⓔ Checksum(LG TV): Changeable by total EDID data.
- ⓕ Vendor Specific(HDMI)

5.2.4.1. EDID

DTS HDMI1 (C/S: A0,F3)_6G_2D ONLY_UHD Deep Color ON

	0	1	2	3	4	5	6	7	8	9	A	B	C	D	E	F
0	00	FF	FF	FF	FF	FF	FF	00	1E	6D	01	00	01	01	01	01
10	01	19	01	03	80	A0	5A	78	0A	EE	91	A3	54	4C	99	26
20	0F	50	54	A1	08	00	31	40	45	40	61	40	71	40	81	80
30	01	01	01	01	01	01	08	E8	00	30	F2	70	5A	80	B0	58
40	8A	00	40	84	63	00	00	1E	02	3A	80	18	71	38	2D	40
50	58	2C	45	00	40	84	63	00	00	1E	00	00	00	FD	00	3A
60	3E	1E	88	3C	00	0A	20	20	20	20	20	20	20	00	00	FC
70	00	4C	47	20	54	56	0A	20	20	20	20	20	20	20	01	A0

	0	1	2	3	4	5	6	7	8	9	A	B	C	D	E	F
0	02	03	3E	F1	50	90	22	20	05	04	03	02	01	61	5D	5E
10	5F	66	62	63	64	2C	3D	06	C0	15	07	50	09	57	07	6E
20	03	0C	00	10	00	B8	3C	20	00	80	01	02	03	04	67	D8
30	5D	C4	01	78	80	03	E3	05	C0	00	E3	0F	00	11	66	21
40	50	B0	51	00	1B	30	40	70	36	00	40	84	63	00	00	1E
50	01	1D	00	72	51	D0	1E	20	6E	28	55	00	40	84	63	00
60	00	1E	00	00	00	00	00	00	00	00	00	00	00	00	00	00
70	00	00	00	00	00	00	00	00	00	00	00	00	00	00	00	F3

DTS HDMI2 (C/S: A0,E3)_6G_2D ONLY_UHD Deep Color ON

	0	1	2	3	4	5	6	7	8	9	A	B	C	D	E	F
0	00	FF	FF	FF	FF	FF	FF	00	1E	6D	01	00	01	01	01	01
10	01	19	01	03	80	A0	5A	78	0A	EE	91	A3	54	4C	99	26
20	0F	50	54	A1	08	00	31	40	45	40	61	40	71	40	81	80
30	01	01	01	01	01	01	08	E8	00	30	F2	70	5A	80	B0	58
40	8A	00	40	84	63	00	00	1E	02	3A	80	18	71	38	2D	40
50	58	2C	45	00	40	84	63	00	00	1E	00	00	00	FD	00	3A
60	3E	1E	88	3C	00	0A	20	20	20	20	20	20	20	00	00	FC
70	00	4C	47	20	54	56	0A	20	20	20	20	20	20	20	01	A0

DTS HDMI3 (C/S: E6,60)_3G_2D ONLY_UHD Deep Color OFF

	0	1	2	3	4	5	6	7	8	9	A	B	C	D	E	FC
00	00	FF	FF	FF	FF	FF	FF	00	1E	6D	01	00	01	01	01	01
10	01	19	01	03	80	A0	5A	78	0A	EE	91	A3	54	4C	99	26
20	0F	50	54	A1	08	00	31	40	45	40	61	40	71	40	81	80
30	01	01	01	01	01	01	02	3A	80	18	71	38	2D	40	58	2C
40	45	00	40	84	63	00	00	1E	66	21	50	B0	51	00	1B	30
50	40	70	36	00	40	84	63	00	00	1E	00	00	00	FD	00	3A
60	3E	1E	53	10	00	0A	20	20	20	20	20	20	20	00	00	FC
70	00	4C	47	20	54	56	0A	20	20	20	20	20	20	20	01	E6

	0	1	2	3	4	5	6	7	8	9	A	B	C	D	E	F
0	02	03	3E	F1	50	90	22	20	05	04	03	02	01	5D	5E	
10	5F	66	62	63	64	2C	3D	06	C0	15	07	50	09	57	07	6E
20	03	0C	00	20	00	B8	3C	20	00	80	01	02	03	04	67	D8
30	5D	C4	01	78	80	03	E3	05	C0	00	E3	0F	00	11	66	21
40	50	B0	51	00	1B	30	40	70	36	00	40	84	63	00	00	1E
50	01	1D	00	72	51	D0	1E	20	6E	28	55	00	40	84	63	00
60	00	1E	00	00	00	00	00	00	00	00	00	00	00	00	00	00
70	00	00	00	00	00	00	00	00	00	00	00	00	00	00	00	E3

	0	1	2	3	4	5	6	7	8	9	A	B	C	D	E	F
0	02	03	30	F1	4E	90	22	20	05	04	03	02	01	5D	5E	5F
10	62	63	64	2C	3D	06	C0	15	07	50	09	57	07	6E	03	0C
20	00	30	00	B8	3C	20	00	80	01	02	03	04	E3	0E	61	66
30	01	1D	80	18	71	1C	16	20	58	2C	25	00	40	84	63	00
40	00	9E	01	1D	00	72	51	D0	1E	20	6E	28	55	00	40	84
50	63	00	00	1E	00	00	00	00	00	00	00	00	00	00	00	00
60	00	00	00	00	00	00	00	00	00	00	00	00	00	00	00	00
70	00	00	00	00	00	00	00	00	00	00	00	00	00	00	00	60

DTS HDMI1 (C/S: E6,80)_3G_2D ONLY_UHD Deep Color OFF

	0	1	2	3	4	5	6	7	8	9	A	B	C	D	E	FC
00	00	FF	FF	FF	FF	FF	FF	00	1E	6D	01	00	01	01	01	01
10	01	19	01	03	80	A0	5A	78	0A	EE	91	A3	54	4C	99	26
20	0F	50	54	A1	08	00	31	40	45	40	61	40	71	40	81	80
30	01	01	01	01	01	01	02	3A	80	18	71	38	2D	40	58	2C
40	45	00	40	84	63	00	00	1E	66	21	50	B0	51	00	1B	30
50	40	70	36	00	40	84	63	00	00	1E	00	00	00	FD	00	3A
60	3E	1E	53	10	00	0A	20	20	20	20	20	20	20	00	00	FC
70	00	4C	47	20	54	56	0A	20	20	20	20	20	20	20	01	E6

AC3 HDMI1 (C/S: A0,FC)_6G_2D ONLY_UHD Deep Color ON

	0	1	2	3	4	5	6	7	8	9	A	B	C	D	E	F
0	00	FF	FF	FF	FF	FF	FF	00	1E	6D	01	00	01	01	01	01
10	01	19	01	03	80	A0	5A	78	0A	EE	91	A3	54	4C	99	26
20	0F	50	54	A1	08	00	31	40	45	40	61	40	71	40	81	80
30	01	01	01	01	01	01	08	E8	00	30	F2	70	5A	80	B0	58
40	8A	00	40	84	63	00	00	1E	02	3A	80	18	71	38	2D	40
50	58	2C	45	00	40	84	63	00	00	1E	00	00	00	FD	00	3A
60	3E	1E	88	3C	00	0A	20	20	20	20	20	20	20	00	00	FC
70	00	4C	47	20	54	56	0A	20	20	20	20	20	20	20	01	A0

	0	1	2	3	4	5	6	7	8	9	A	B	C	D	E	F
0	02	03	30	F1	4E	90	22	20	05	04	03	02	01	5D	5E	5F
10	62	63	64	2C	3D	06	C0	15	07	50	09	57	07	6E	03	0C
20	00	10	00	B8	3C	20	00	80	01	02	03	04	E3	0E	61	66
30	01	1D	80	18	71	1C	16	20	58	2C	25	00	40	84	63	00
40	00	9E	01	1D	00	72	51	D0	1E	20	6E	28	55	00	40	84
50	63	00	00	1E	00	00	00	00	00	00	00	00	00	00	00	00
60	00	00	00	00	00	00	00	00	00	00	00	00	00	00	00	00
70	00	00	00	00	00	00	00	00	00	00	00	00	00	00	00	80

	0	1	2	3	4	5	6	7	8	9	A	B	C	D	E	F
0	02	03	38	F1	50	90	22	20	05	04	03	02	01	61	5D	5E
10	5F	66	62	63	64	26	15	07	50	09	57	07	7C	03	0C	00
20	10	00	B8	3C	20	00	80	01	02	03	04	67	D8	5D	C4	01
30	78	80	03	E3	05	C0	00	E3	0F	00	11	66	21	50	B0	51
40	00	1B	30	40	70	36	00	40	84	63	00	00	1E	01	1D	00
50	72	51	D0	1E	20	6E	28	55	00	40	84	63	00	00	1E	00
60	00	00	00	00	00	00	00	00	00	00	00	00	00	00	00	00
70	00	00	00	00	00	00	00	00	00	00	00	00	00	00	00	FC

DTS HDMI2 (C/S: E6,70)_3G_2D ONLY_UHD Deep Color OFF

	0	1	2	3	4	5	6	7	8	9	A	B	C	D	E	FC
00	00	FF	FF	FF	FF	FF	FF	00	1E	6D	01	00	01	01	01	01
10	01	19	01	03	80	A0	5A	78	0A	EE	91	A3	54	4C	99	26
20	0F	50	54	A1	08	00	31	40	45	40	61	40	71	40	81	80
30	01	01	01	01	01	01	02	3A	80	18	71	38	2D	40	58	2C
40	45	00	40	84	63	00	00	1E	66	21	50	B0	51	00	1B	30
50	40	70	36	00	40	84	63	00	00	1E	00	00	00	FD	00	3A
60	3E	1E	53	10	00	0A	20	20	20	20	20	20	20	00	00	FC
70	00	4C	47	20	54	56	0A	20	20	20	20	20	20	20	01	E6

AC3 HDMI2 (C/S: A0,EC)_6G_2D ONLY_UHD Deep Color ON

	0	1	2	3	4	5	6	7	8	9	A	B	C	D	E	F
0	00	FF	FF	FF	FF	FF	FF	00	1E	6D	01	00	01			

AC3 HDMI1 (C/S: A0,FC)_6G_2D ONLY_UHD Deep Color ON

	0	1	2	3	4	5	6	7	8	9	A	B	C	D	E	F
0	00	FF	FF	FF	FF	FF	FF	00	1E	6D	01	00	01	01	01	01
10	01	19	01	03	80	A0	5A	78	0A	EE	91	A3	54	4C	99	26
20	0F	50	54	A1	08	00	31	40	45	40	61	40	71	40	81	80
30	01	01	01	01	01	01	08	E8	00	30	F2	70	5A	80	B0	58
40	8A	00	40	84	63	00	00	1E	02	3A	80	18	71	38	2D	40
50	58	2C	45	00	40	84	63	00	00	1E	00	00	00	FD	00	3A
60	3E	1E	88	3C	00	0A	20	20	20	20	20	20	20	00	00	FC
70	00	4C	47	20	54	56	0A	20	20	20	20	20	20	01	A0	

	0	1	2	3	4	5	6	7	8	9	A	B	C	D	E	F
0	02	03	3B	F1	50	90	22	20	05	04	03	02	01	61	5D	5E
10	5F	66	62	63	64	26	15	07	50	09	57	07	7C	03	0C	00
20	10	00	B8	3C	20	00	80	01	02	03	04	67	D8	5D	C4	01
30	78	80	03	E3	05	C0	00	E3	0F	00	11	66	21	50	B0	51
40	00	1B	30	40	70	36	00	40	84	63	00	00	1E	01	1D	00
50	72	51	D0	1E	20	6E	28	55	00	40	84	63	00	00	1E	00
60	00	00	00	00	00	00	00	00	00	00	00	00	00	00	00	00
70	00	00	00	00	00	00	00	00	00	00	00	00	00	00	00	FC

AC3 HDMI2 (C/S: A0,EC)_6G_2D ONLY_UHD Deep Color ON

	0	1	2	3	4	5	6	7	8	9	A	B	C	D	E	F
0	00	FF	FF	FF	FF	FF	FF	00	1E	6D	01	00	01	01	01	01
10	01	19	01	03	80	A0	5A	78	0A	EE	91	A3	54	4C	99	26
20	0F	50	54	A1	08	00	31	40	45	40	61	40	71	40	81	80
30	01	01	01	01	01	01	08	E8	00	30	F2	70	5A	80	B0	58
40	8A	00	40	84	63	00	00	1E	02	3A	80	18	71	38	2D	40
50	58	2C	45	00	40	84	63	00	00	1E	00	00	00	FD	00	3A
60	3E	1E	88	3C	00	0A	20	20	20	20	20	20	20	00	00	FC
70	00	4C	47	20	54	56	0A	20	20	20	20	20	20	01	A0	

	0	1	2	3	4	5	6	7	8	9	A	B	C	D	E	F
0	02	03	3B	F1	50	90	22	20	05	04	03	02	01	61	5D	5E
10	5F	66	62	63	64	26	15	07	50	09	57	07	7C	03	0C	00
20	20	00	B8	3C	20	00	80	01	02	03	04	67	D8	5D	C4	01
30	78	80	03	E3	05	C0	00	E3	0F	00	11	66	21	50	B0	51
40	00	1B	30	40	70	36	00	40	84	63	00	00	1E	01	1D	00
50	72	51	D0	1E	20	6E	28	55	00	40	84	63	00	00	1E	00
60	00	00	00	00	00	00	00	00	00	00	00	00	00	00	00	00
70	00	00	00	00	00	00	00	00	00	00	00	00	00	00	00	EC

AC3 HDMI1 (C/S: E6,89)_3G_2D ONLY_UHD Deep Color OFF

	0	1	2	3	4	5	6	7	8	9	A	B	C	D	E	FC
00	00	FF	FF	FF	FF	FF	FF	00	1E	6D	01	00	01	01	01	01
10	01	19	01	03	80	A0	5A	78	0A	EE	91	A3	54	4C	99	26
20	0F	50	54	A1	08	00	31	40	45	40	61	40	71	40	81	80
30	01	01	01	01	01	01	02	3A	80	18	71	38	2D	40	58	2C
40	45	00	40	84	63	00	00	1E	66	21	50	B0	51	00	1B	30
50	40	70	36	00	40	84	63	00	00	1E	00	00	00	FD	00	3A
60	3E	1E	88	3C	00	0A	20	20	20	20	20	20	20	00	00	FC
70	00	4C	47	20	54	56	0A	20	20	20	20	20	20	01	E6	

	0	1	2	3	4	5	6	7	8	9	A	B	C	D	E	F
0	02	03	3B	F1	50	90	22	20	05	04	03	02	01	61	5D	5E
10	62	63	64	26	15	07	50	09	57	07	6E	03	0C	00	10	00
20	B8	3C	20	00	80	01	02	03	04	E3	0E	61	66	01	1D	80
30	18	71	1C	16	20	58	2C	25	00	40	84	63	00	00	9E	01
40	1D	00	72	51	D0	1E	20	6E	28	55	00	40	84	63	00	00
50	1E	00	00	00	00	00	00	00	00	00	00	00	00	00	00	00
60	00	00	00	00	00	00	00	00	00	00	00	00	00	00	00	00
70	00	00	00	00	00	00	00	00	00	00	00	00	00	00	00	89

AC3 HDMI2 (C/S: E6,79)_3G_2D ONLY_UHD Deep Color OFF

	0	1	2	3	4	5	6	7	8	9	A	B	C	D	E	FC
00	00	FF	FF	FF	FF	FF	FF	00	1E	6D	01	00	01	01	01	01
10	01	19	01	03	80	A0	5A	78	0A	EE	91	A3	54	4C	99	26
20	0F	50	54	A1	08	00	31	40	45	40	61	40	71	40	81	80
30	01	01	01	01	01	01	02	3A	80	18	71	38	2D	40	58	2C
40	45	00	40	84	63	00	00	1E	66	21	50	B0	51	00	1B	30
50	40	70	36	00	40	84	63	00	00	1E	00	00	00	FD	00	3A
60	3E	1E	88	3C	00	0A	20	20	20	20	20	20	20	00	00	FC
70	00	4C	47	20	54	56	0A	20	20	20	20	20	20	01	E6	

	0	1	2	3	4	5	6	7	8	9	A	B	C	D	E	F
0	02	03	2D	F1	4E	90	22	20	05	04	03	02	01	5D	5E	5F
10	62	63	64	26	15	07	50	09	57	07	6E	03	0C	00	20	00
20	B8	3C	20	00	80	01	02	03	04	E3	0E	61	66	01	1D	80
30	18	71	1C	16	20	58	2C	25	00	40	84	63	00	00	9E	01
40	1D	00	72	51	D0	1E	20	6E	28	55	00	40	84	63	00	00
50	1E	00	00	00	00	00	00	00	00	00	00	00	00	00	00	00
60	00	00	00	00	00	00	00	00	00	00	00	00	00	00	00	00
70	00	00	00	00	00	00	00	00	00	00	00	00	00	00	00	79

AC3 HDMI3 (C/S: E6,69)_3G_2D ONLY_UHD Deep Color OFF

	0	1	2	3	4	5	6	7	8	9	A	B	C	D	E	FC
00	00	FF	FF	FF	FF	FF	FF	00	1E	6D	01	00	01	01	01	01
10	01	19	01	03	80	A0	5A	78	0A	EE	91	A3	54	4C	99	26
20	0F	50	54	A1	08	00	31	40	45	40	61	40	71	40	81	80
30	01	01	01	01	01	01	02	3A	80	18	71	38	2D	40	58	2C
40	45	00	40	84	63	00	00	1E	66	21	50	B0	51	00	1B	30
50	40	70	36	00	40	84	63	00	00	1E	00	00	00	FD	00	3A
60	3E	1E	88	3C	00	0A	20	20	20	20	20	20	20	00	00	FC
70	00	4C	47	20	54	56	0A	20	20	20	20	20	20	01	E6	

	0	1	2	3	4	5	6	7	8	9	A	B	C	D	E	F
0	02	03	2D	F1	4E	90	22	20	05	04	03	02	01	5D	5E	5F
10	62	63	64	26	15	07										

PCM HDMI2 (C/S: A0,5E)_6G_2D ONLY_UHD Deep Color ON

0	00	FF	FF	FF	FF	FF	FF	00	1E	6D	01	00	01	01	01	01
10	01	19	01	03	80	A0	5A	78	0A	EE	91	A3	54	4C	99	26
20	0F	50	54	A1	08	00	31	40	45	40	61	40	71	40	81	80
30	01	01	01	01	01	01	08	E8	00	30	F2	70	5A	80	B0	58
40	8A	00	40	84	63	00	00	1E	02	3A	80	18	71	38	2D	40
50	58	2C	45	00	40	84	63	00	00	1E	00	00	00	FD	00	3A
60	3E	1E	88	3C	00	0A	20	20	20	20	20	20	20	00	00	FC
70	00	4C	47	20	54	56	0A	20	20	20	20	20	20	01	A0	

0	02	03	38	F1	50	90	22	20	05	04	03	02	01	61	5D	5E
10	5F	66	62	63	64	23	09	57	07	6E	03	0C	00	20	00	B8
20	3C	20	00	80	01	02	03	04	67	D8	5D	C4	01	78	80	03
30	E3	05	C0	00	E3	0F	00	11	66	21	50	B0	51	00	1B	30
40	40	70	36	00	40	84	63	00	00	1E	01	1D	00	72	51	D0
50	1E	20	6E	28	55	00	40	84	63	00	00	1E	00	00	00	00
60	00	00	00	00	00	00	00	00	00	00	00	00	00	00	00	00
70	00	00	00	00	00	00	00	00	00	00	00	00	00	00	00	5E

PCM HDMI2 (C/S: E6,FB)_6G_2D ONLY_UHD Deep Color ON

00	00	FF	FF	FF	FF	FF	FF	00	1E	6D	01	00	01	01	01	01
10	01	19	01	03	80	A0	5A	78	0A	EE	91	A3	54	4C	99	26
20	0F	50	54	A1	08	00	31	40	45	40	61	40	71	40	81	80
30	01	01	01	01	01	01	02	3A	80	18	71	38	2D	40	58	2C
40	45	00	40	84	63	00	00	1E	66	21	50	B0	51	00	1B	30
50	40	70	36	00	40	84	63	00	00	1E	00	00	00	FD	00	3A
60	3E	1E	53	10	00	0A	20	20	20	20	20	20	20	00	00	FC
70	00	4C	47	20	54	56	0A	20	20	20	20	20	20	01	E6	

0	02	03	2A	F1	4E	90	22	20	05	04	03	02	01	5D	5E	5F
10	62	63	64	23	09	57	07	6E	03	0C	00	10	00	B8	3C	20
20	00	80	01	02	03	04	E3	0E	61	66	01	1D	80	18	71	1C
30	16	20	58	2C	25	00	40	84	63	00	00	9E	01	1D	00	72
40	51	D0	1E	20	6E	28	55	00	40	84	63	00	00	1E	00	00
50	00	00	00	00	00	00	00	00	00	00	00	00	00	00	00	00
60	00	00	00	00	00	00	00	00	00	00	00	00	00	00	00	00
70	00	00	00	00	00	00	00	00	00	00	00	00	00	00	00	FB

PCM HDMI2 (C/S: E6,EB)_3G_2D ONLY_UHD Deep Color OFF

00	00	FF	FF	FF	FF	FF	FF	00	1E	6D	01	00	01	01	01	01
10	01	19	01	03	80	A0	5A	78	0A	EE	91	A3	54	4C	99	26
20	0F	50	54	A1	08	00	31	40	45	40	61	40	71	40	81	80
30	01	01	01	01	01	01	02	3A	80	18	71	38	2D	40	58	2C
40	45	00	40	84	63	00	00	1E	66	21	50	B0	51	00	1B	30
50	40	70	36	00	40	84	63	00	00	1E	00	00	00	FD	00	3A
60	3E	1E	53	10	00	0A	20	20	20	20	20	20	20	00	00	FC
70	00	4C	47	20	54	56	0A	20	20	20	20	20	20	01	E6	

0	02	03	2A	F1	4E	90	22	20	05	04	03	02	01	5D	5E	5F
10	62	63	64	23	09	57	07	6E	03	0C	00	20	00	B8	3C	20
20	00	80	01	02	03	04	E3	0E	61	66	01	1D	80	18	71	1C
30	16	20	58	2C	25	00	40	84	63	00	00	9E	01	1D	00	72
40	51	D0	1E	20	6E	28	55	00	40	84	63	00	00	1E	00	00
50	00	00	00	00	00	00	00	00	00	00	00	00	00	00	00	00
60	00	00	00	00	00	00	00	00	00	00	00	00	00	00	00	00
70	00	00	00	00	00	00	00	00	00	00	00	00	00	00	00	EB

PCM HDMI3 (C/S: E6,DB)_3G_2D ONLY_UHD Deep Color OFF(Except UF6400 North America models)

0	00	FF	FF	FF	FF	FF	FF	00	1E	6D	01	00	01	01	01	01
10	01	19	01	03	80	A0	5A	78	0A	EE	91	A3	54	4C	99	26
20	0F	50	54	A1	08	00	31	40	45	40	61	40	71	40	81	80
30	01	01	01	01	01	01	02	3A	80	18	71	38	2D	40	58	2C
40	45	00	40	84	63	00	00	1E	66	21	50	B0	51	00	1B	30
50	40	70	36	00	40	84	63	00	00	1E	00	00	00	FD	00	3A
60	3E	1E	53	10	00	0A	20	20	20	20	20	20	20	00	00	FC
70	00	4C	47	20	54	56	0A	20	20	20	20	20	20	01	E6	

0	02	03	2A	F1	4E	90	22	20	05	04	03	02	01	5D	5E	5F
10	62	63	64	23	09	57	07	6E	03	0C	00	30	00	B8	3C	20
20	00	80	01	02	03	04	E3	0E	61	66	01	1D	80	18	71	1C
30	16	20	58	2C	25	00	40	84	63	00	00	9E	01	1D	00	72
40	51	D0	1E	20	6E	28	55	00	40	84	63	00	00	1E	00	00
50	00	00	00	00	00	00	00	00	00	00	00	00	00	00	00	00
60	00	00	00	00	00	00	00	00	00	00	00	00	00	00	00	00
70	00	00	00	00	00	00	00	00	00	00	00	00	00	00	00	DB

* Checksum (HDMI 1/2/3/4)

2D	DTS	AC3	PCM
HDMI1	E6/80	A0/F3	E6/89 A0/FC E6/FB A0/6E
HDMI2	E6/70	A0/E3	E6/79 A0/EC E6/EB A0/5E
HDMI3	E6/60		E6/69 E6/DB

5.3. Camera Port Inspection

- Objective : To check how it connects between Camera and PCBA normally, and their Function
- Test Method : This Inspection is available only Power-Only Status.
 - Push Camera Up
 - Camera's Preview picture appears on TV Set
 - Push Camera Down

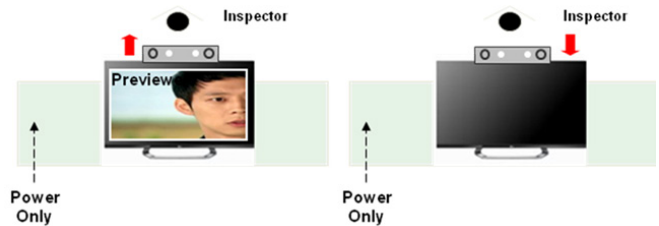

(3) RS-232C Command

RS-232C COMMAND			Explanation
CMD	DATA	ID	
Ai	00	23	Camera Function Start.
Ai	00	24	Camera Function End.

5.4. V-COM Adjust

(ONLY FOR EPI model, 43/49/55UF68/64 & 65UF7702)

5.4.1. Overview

- V-COM adj. Objective & How-it-works
- Objective: To reduce each Panel's V-COM voltage deviation
- How-it-works: When V-COM gain in the adjust-OSD of each SET is at default value, each SET can have flicker by each Panel's V-COM voltage deviation. In order to prevent flicker of each SET, find the desired each Panel's V-COM voltage value.
- Adj. condition: normal temperature
 - 1) Surrounding Temperature: 25±5 °C
 - 2) Warm-up time: About 5 Min
 - 3) Surrounding Humidity: 20% ~ 80%

5.4.2. Equipment

- (1) Color Analyzer: CA-310 (LED Module : CH 14) or CM-H505
- (2) Adj. Computer (During auto adj., RS-232C protocol is needed)
- (3) Adjust Remocon
- (4) Signal : internal flicker Pattern in SET
 - Color Analyzer Matrix should be calibrated using CS-100

5.4.3. Equipment connection MAP

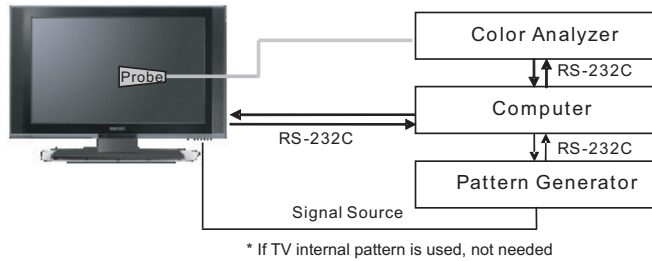

5.4.4. Adj. Command (Protocol)

<Command Format>
CMD ID DATA CR RF

- CMD: Command
 - ID : Command
 - Data : Command
- Ex) [Send: va 00 00\r\n]

(1) RS-232C Command used during auto-adj.

RS-232C COMMAND			Explanation
CMD	DATA	ID	
va	00	00	V-com pattern
vb	00	00 ~ FE	V-com adj.(internal Flicker pattern)
wb	00	FF	V-com adj. completed

5.4.5. Adjustment method

- (1) Set TV in POWER-ONLY mode using POWER ONLY key
 - (2) Zero calibrate probe then place it on the center of the Display
 - (3) Connect Cable (RS-232C to USB)
 - (4) Select Model in "V-com adj. Program" and begin "V-com adj."
 - (5) When V-com adj. is complete (OK)
 - (6) Remove probe and RS-232C to USB cable to complete adj.
- V-com Adj. must begin as start command "va 00 00" , and finish as end command "wb 00 ff"

▪ V-com adjust data

	43" inch		49" inch		55" inch		65" inch	
	V-com Data							
	hex	dec	hex	dec	hex	dec	hex	dec
Max	B4	180	8B	139	85	133	AB	171
Default	96	150	6D	109	68	104	8D	141
Min	78	120	4F	79	49	73	6F	111

5.4.5.1 Manual adj. method
TBD

5.5. White Balance Adjustment

5.5.1. Overview

5.5.1.1. W/B adj. Objective & How-it-works

- (1) Objective: To reduce each Panel's W/B deviation
- (2) How-it-works: When R/G/B gain in the OSD is at 192, it means the panel is at its Full Dynamic Range. In order to prevent saturation of Full Dynamic range and data, one of R/G/B is fixed at 192, and the other two is lowered to find the desired value.
- (3) Adj. condition: normal temperature
 - Surrounding Temperature: 25±5 °C
 - Warm-up time: About 5 Min
 - Surrounding Humidity: 20% ~ 80%

5.5.2. Equipment

- (1) Color Analyzer: CA-210 (LED Module : CH 14)
 - (2) Adj. Computer (During auto adj., RS-232C protocol is needed)
 - (3) Adjust Remocon
 - (4) Video Signal Generator MSPG-925F 720p/204-Gray (Model: 217, Pattern: 49)
- ※ Color Analyzer Matrix should be calibrated using CS-1000

5.5.3. Equipment connection MAP

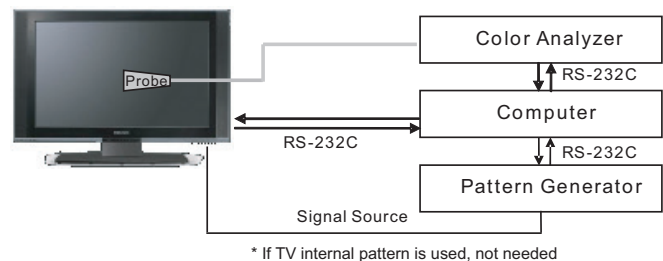

5.5.4. Adj. Command (Protocol)

<Command Format>

START 6E A 50 A LEN A 03 A CMD A 00 A VAL A CS A STOP

- LEN: Number of Data Byte to be sent
 - CMD : Command
 - VAL : FOS Data value
 - CS : Checksum of sent data
 - A : Acknowledge
- Ex) [Send: JA_00_DD] / [Ack: A_00_okDDX]

(1) RS-232C Command used during auto-adj.

RS-232C COMMAND			Explanation
CMD	DATA	ID	
wb	00	00	Begin White Balance adj.
wb	00	10	Gain adj.(internal white pattern)
wb	00	1f	Gain adj. completed
wb	00	20	Offset adj.(internal white pattern)
wb	00	2f	Offset adj. completed
wb	00	ff	End White Balance adj. (internal pattern disappears)

Ex) wb 00 00 -> Begin white balance auto-adj.
 wb 00 10 -> Gain adj.
 ja 00 ff -> Adj. data
 jb 00 c0
 ...
 ...

wb 00 1f -> Gain adj. complete
 *(wb 00 20(start), wb 00 2f(endc)) -> Off-set adj.
 wb 00 ff -> End white balance auto adj.

(2) Adjustment Map
 - Applied Model : ALL MODELS

	Adj. item	Command (lower caseASCII)		Data Range (Hex.)		Default (Decimal)
		CMD1	CMD2	MIN	MAX	
Cool	R Gain	j	g	00	C0	TBD
	G Gain	j	h	00	C0	TBD
	B Gain	j	i	00	C0	TBD
	R Cut					TBD
	G Cut					TBD
	B Cut					TBD
Medium	R Gain	j	a	00	C0	TBD
	G Gain	j	b	00	C0	TBD
	B Gain	j	c	00	C0	TBD
	R Cut					TBD
	G Cut					TBD
	B Cut					TBD
Warm	R Gain	j	d	00	C0	TBD
	G Gain	j	e	00	C0	TBD
	B Gain	j	f	00	C0	TBD
	R Cut					TBD
	G Cut					TBD
	B Cut					TBD

5.5.5. Adjustment method

5.5.5.1. Auto WB calibration

- (1) Set TV in adj. mode using POWER ONNY key
 - (2) Zero calibrate probe then place it on the center of the Display
 - (3) Connect Cable (RS-232C to USB)
 - (4) Select mode in adj. Program and begin adj.
 - (5) When adj. is complete (OK Sign), check adj. status pre mode(Warm, Medium, Cool)
 - (6) Remove probe and RS-232C to USB cable to complete adj.
- W/B Adj. must begin as start command "wb 00 00" , and finish as end command "wb 00 ff", and Adj. offset if need

5.5.5.2. Manual adj. method

- (1) Set TV in Adj. mode using POWER ON
- (2) Zero Calibrate the probe of Color Analyzer, then place it on the center of LCD module within 10cm of the surface..
- (3) Press ADJ key -> EZ adjust using adj. R/C -> 7. White-Balance then press the cursor to the right (KEY▶).
(When KEY(▶) is pressed 216 Gray internal pattern will be displayed)
- (4) One of R Gain / G Gain / B Gain should be fixed at 192, and the rest will be lowered to meet the desired value.
- (5) Adj. is performed in COOL, MEDIUM, WARM 3 modes of color temperature.

** R-fix adjustment

Adjust modes (Cool), Fix the R gain to 210 (default data) and change the others (G/B Gain).

- Adjust the R gain more than 210 (If G gain or B gain is less than 0 , R gain can adjust more than 210) and change the others (G/B Gain).

Adjust two modes (Medium / Warm), Fix the one of R/G/B gain to 192 (default data) and decrease the others.

- If internal pattern is not available, use RF input. In EZ Adj. menu 7.White Balance, you can select one of 2 Test-pattern: ON, OFF. Default is inner(ON). By selecting OFF, you can adjust using RF signal in 216 Gray pattern.

- Adj. condition and cautionary items

- (1) Lighting condition in surrounding area
Surrounding lighting should be lower 10 lux. Try to isolate adj. area into dark surrounding.

- (2) Probe location

- LCD : Color Analyzer (CA-210) probe should be within 10cm and perpendicular of the module surface (80°~ 100°)

- (3) Aging time

- After Aging Start, Keep the Power ON status during 5 Minutes.

- In case of LCD, Back-light on should be checked using no signal or Full-white pattern.

5.5.6. Reference (White Balance Adj. coordinate and color temperature)

- Luminance: 206 Gray
- Standard color coordinate and temperature using CS-1000 (over 26 inch)

Mode	Coordinate		Temp	Δuv
	X	Y		
Cool	0.271	0.270	13,000K	0.0000
Medium	0.283	0.289	9,300K	0.0000
Warm	0.313	0.329	6,500K	0.0000

- Standard color coordinate and temperature using CA-210 (CH 14)

Mode	Coordinate		Temp	Δuv
	X	Y		
Cool	0.271±0.002	0.270±0.002	13000K	0.0000
Medium	0.286±0.002	0.289±0.002	9300K	0.0000
Warm	0.313±0.002	0.329±0.002	6500K	0.0000

5.5.7. EDGE & IOL LED White balance table

- Edge & ALEF LED module change color coordinate because of aging time
- apply under the color coordinate table, for compensated aging time
- Luminance: 204 Gray, 80IRE
- ** Except Gumi winter season(Jan~Feb) and except for winter season (Mar ~ Dec) & Global are same as the table below
- Standard color coordinate and temperature using CA-210(CH-14) – by aging time

webOS	Aging time (Min)	Cool		Medium		Warm	
		X	Y	X	Y	X	Y
		271	270	286	289	313	329
1	0-2	282	289	297	308	324	348
2	3-5	281	287	296	306	323	346
3	6-9	279	284	294	303	321	343
4	10-19	277	280	292	299	319	339
5	20-35	275	277	290	296	317	336
6	36-49	274	274	289	293	316	333
7	50-79	273	272	288	291	315	331
8	80-119	272	271	287	290	314	330
9	Over 120	271	270	286	289	313	329

* Use only AUO, INX, Sharp, CSOT, BOE
(Cool temp Spec is 13000K)

	Cool		Medium		Warm	
	x	y	x	y	x	y
spec	271	270	286	289	313	329
target	278	280	293	299	320	339

5.6. Local Dimming Function Check

- (Step 1) Turn on TV
- (Step 2) At the Local Dimming mode, module Edge Backlight moving right to left
Back light of IOP module moving
- (Step 3) confirm the Local Dimming mode
- (Step 4) Press “exit” Key

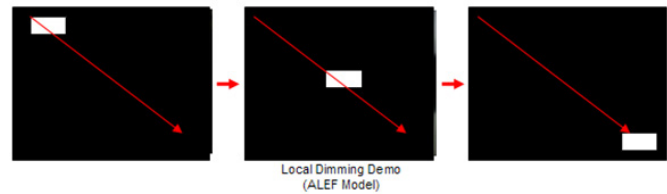
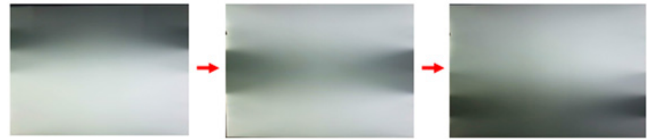

5.7. Magic Motion Remocon test

- Equipment : RF Remocon for test, IR-KEY-Code Remocon for test
- You must confirm the battery power of RF-Remocon before test
(recommend that change the battery per every lot)
- Sequence (test)
 - a) if you select the ‘start key(OK)’ on the controller, you can pairing with the TV SET.
 - b) You can check the cursor on the TV Screen, when select the ‘OK Key’ on the controller
 - c) You must remove the pairing with the TV Set by select ‘Mute + OK Key’ on the controller

5.8 HDMI ARC Function Inspection

5.8.1. Test equipment

- Optic Receiver Speaker
- MSHG-600 (SW: 1220 ↑)
- HDMI Cable (for 1.4 version)

5.8.2. Test method

- (1) Insert the HDMI Cable to the HDMI ARC port from the master equipment (HDMI2)
- (2) Check the sound from the TV Set
- (3) Check the Sound from the Speaker or using AV & Optic TEST program (It’s connected to MSHG-600)

5.9. EYE-Q Green Function Inspection

- (Step 1) Turn on the TV..
- (Step 2) Press 'EYE button' on the adjustment remote-controller.
- (Step 3) Cover 'Eye Q sensor' on the front of set with your hands, hold it for 6 seconds.
- (Step 4) Check "the Sensor Data" on the screen, make certain that Data is below 10. If Data isn't below 10 in 6 seconds, Eye Q sensor would be bad. You should change Eye Q sensor.
- (Step 5) Uncover your hands from Eye Q sensor, hold it for 6 seconds.
- (Step 6) Check "Back Light(xxx)" on the screen, check data increase . You should change Eye Q sensor.

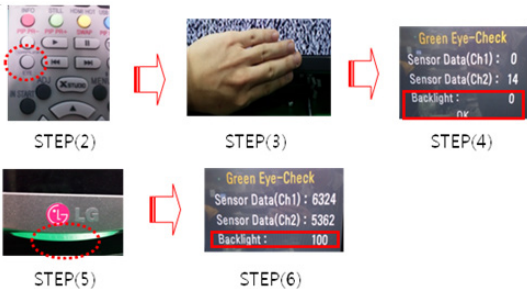

5.10. Ship-out mode check (In-stop)

- After final inspection, press In-Stop key of the Adj. R/C and check that the unit goes to Stand-by mode.

6. GND and Internal Pressure check

6.1. Method

- GND & Internal Pressure auto-check preparation
 - Check that Power Cord is fully inserted to the SET. (If loose, re-insert)
- Perform GND & Internal Pressure auto-check
 - Unit fully inserted Power cord, Antenna cable and A/V arrive to the auto-check process.
 - Connect D-terminal to AV JACK TESTER
 - Auto CONTROLLER(GWS103-4) ON
 - Perform GND TEST
 - If NG, Buzzer will sound to inform the operator.
 - If OK, changeover to I/P check automatically.
 - (Remove CORD, A/V form AV JACK BOX)
 - Perform I/P test
 - If NG, Buzzer will sound to inform the operator.
 - If OK, Good lamp will lit up and the stopper will allow the pallet to move on to next process.



Tuner GND is separated.

6.2. Checkpoint

- Test voltage
 - GND: 1.5KV/min at 100mA
 - SIGNAL: 3KV/min at 100mA
- TEST time: 1 second
- TEST POINT
 - GND Test = POWER CORD GND and SIGNAL CABLE GND.
 - Hi-pot Test = POWER CORD GND and LIVE & NEUTRAL.
- LEAKAGE CURRENT: At 0.5mA

7. AUDIO output check

No	Item	Min	Typ	Max	Unit	Remark
1	Audio practical max Output, L/R (Distortion=10% max Output)		10.0 8.10	12.0 10.8	W Vrms	EQ Off AVL Off Clear Voice Off
2	Speaker (8Ω Impedance)		10	12	W	EQ On AVL On Clear Voice On

*Measurement condition:

- RF input: Mono, 1KHz sine wave signal, 100% Modulation
- CVBS, Component: 1KHz sine wave signal (0.4Vrms)
- RGB PC: 1KHz sine wave signal (0.7Vrms)

8. USB S/W Download (optional, Service only)

- (1) Put the USB Stick to the USB socket
- (2) Automatically detecting update file in USB Stick
- If your downloaded program version in USB Stick is lower than that of TV set, it didn't work. Otherwise USB data is automatically detected.
- (3) Show the message "Copying files from memory"

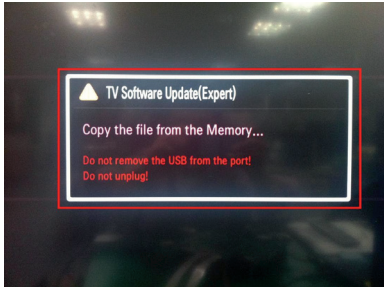

- (4) Updating is starting

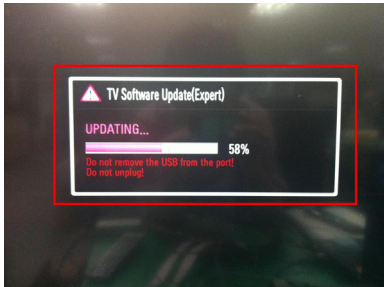

- (5) Updating Completed, The TV will restart automatically



- (6) If your TV is turned on, check your updated version and Tool option.

* If downloading version is more high than your TV have, TV can lost all channel data. In this case, you have to channel recover. If all channel data is cleared, you didn't have a DTV/ATV test on production line.

* After downloading, TOOL OPTION setting is needed again.

- (1) Push "IN-START" key in service remote controller.
- (2) Select "Tool Option 1" and Push "OK" button.
- (3) Punch in the number. (Each model has their number.)

BLOCK DIAGRAM

1. LM14A + URSA11 Circuit Block Diagram

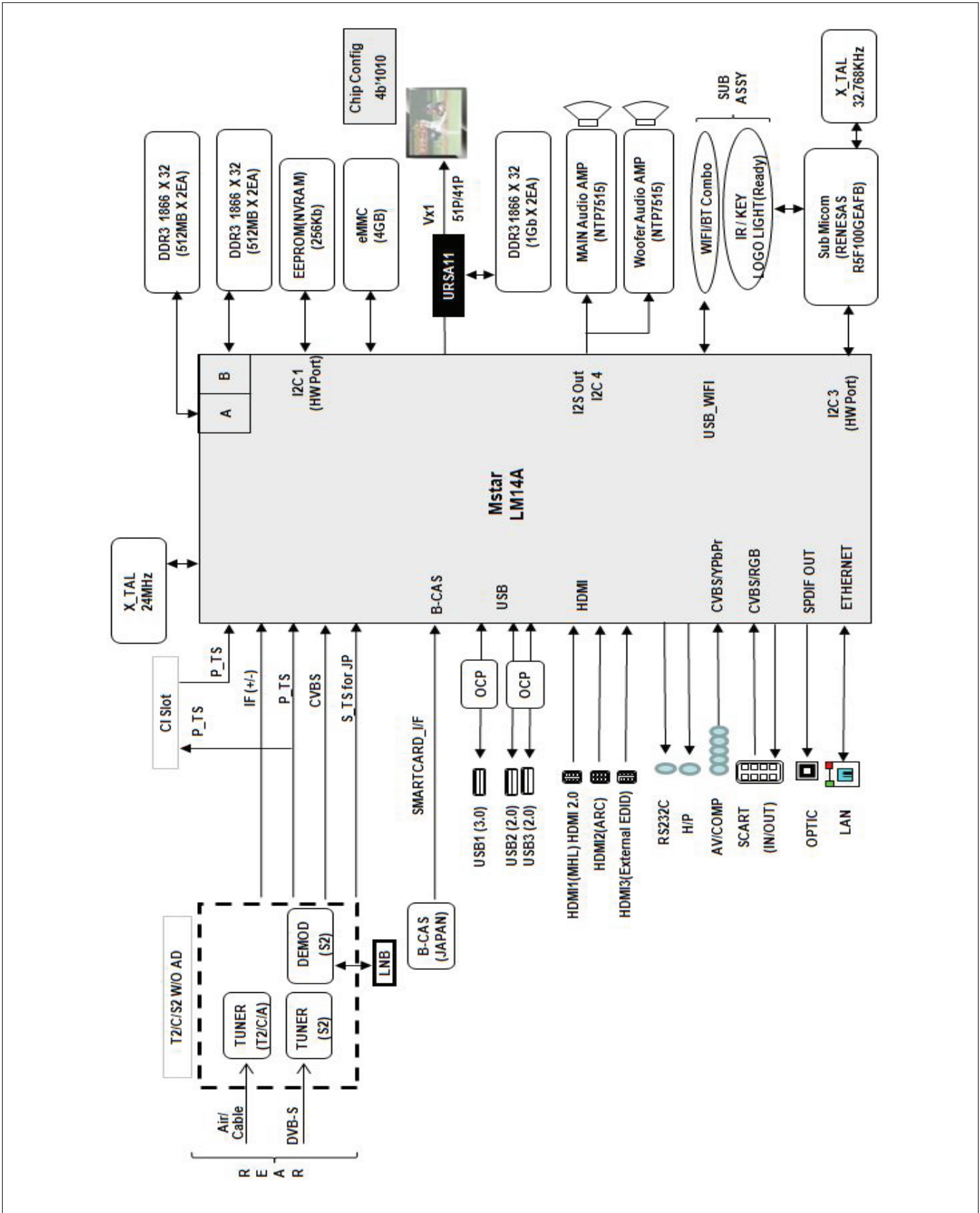

2. LM14A I2C Block Diagram

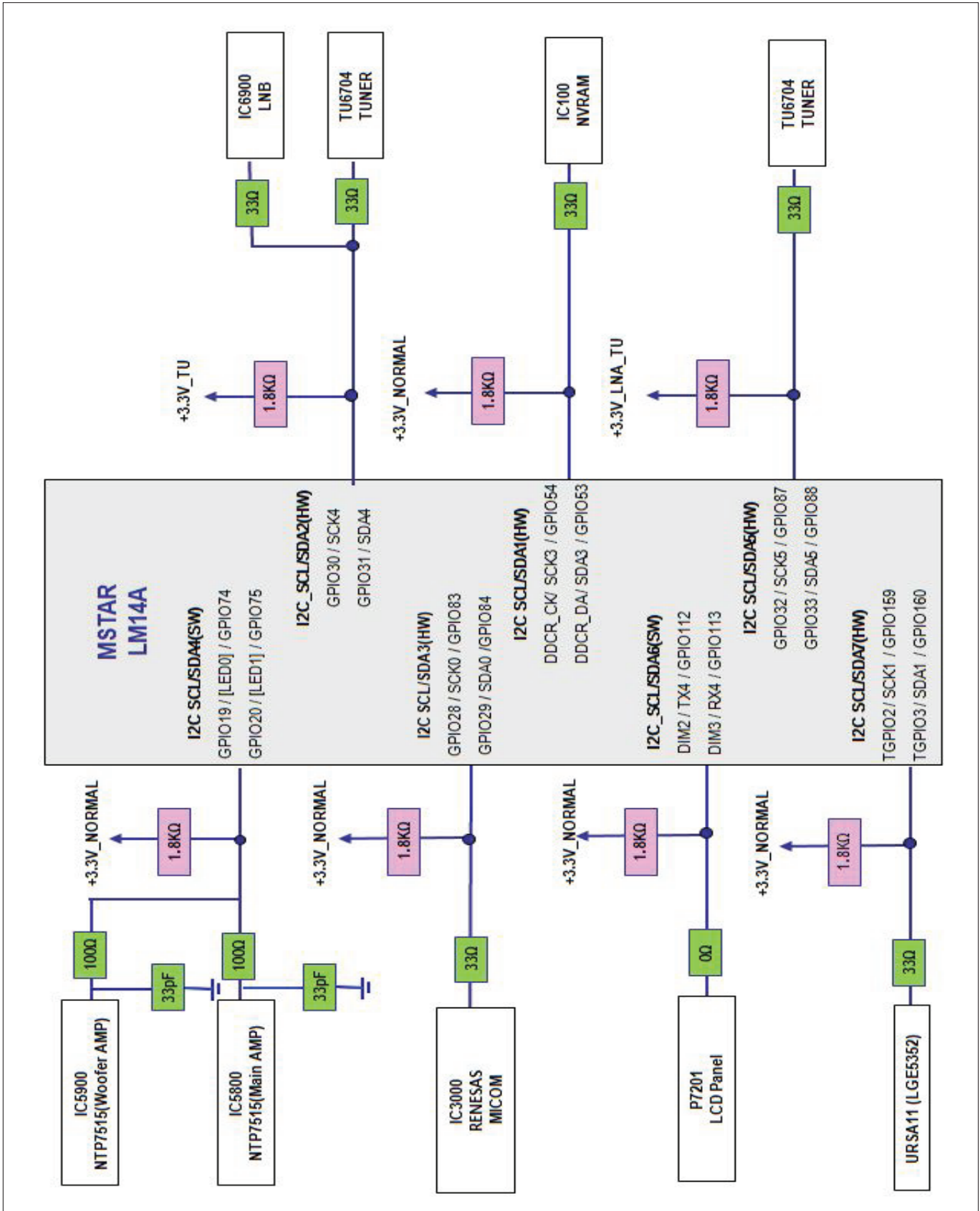

3. URSA11 Block Diagram

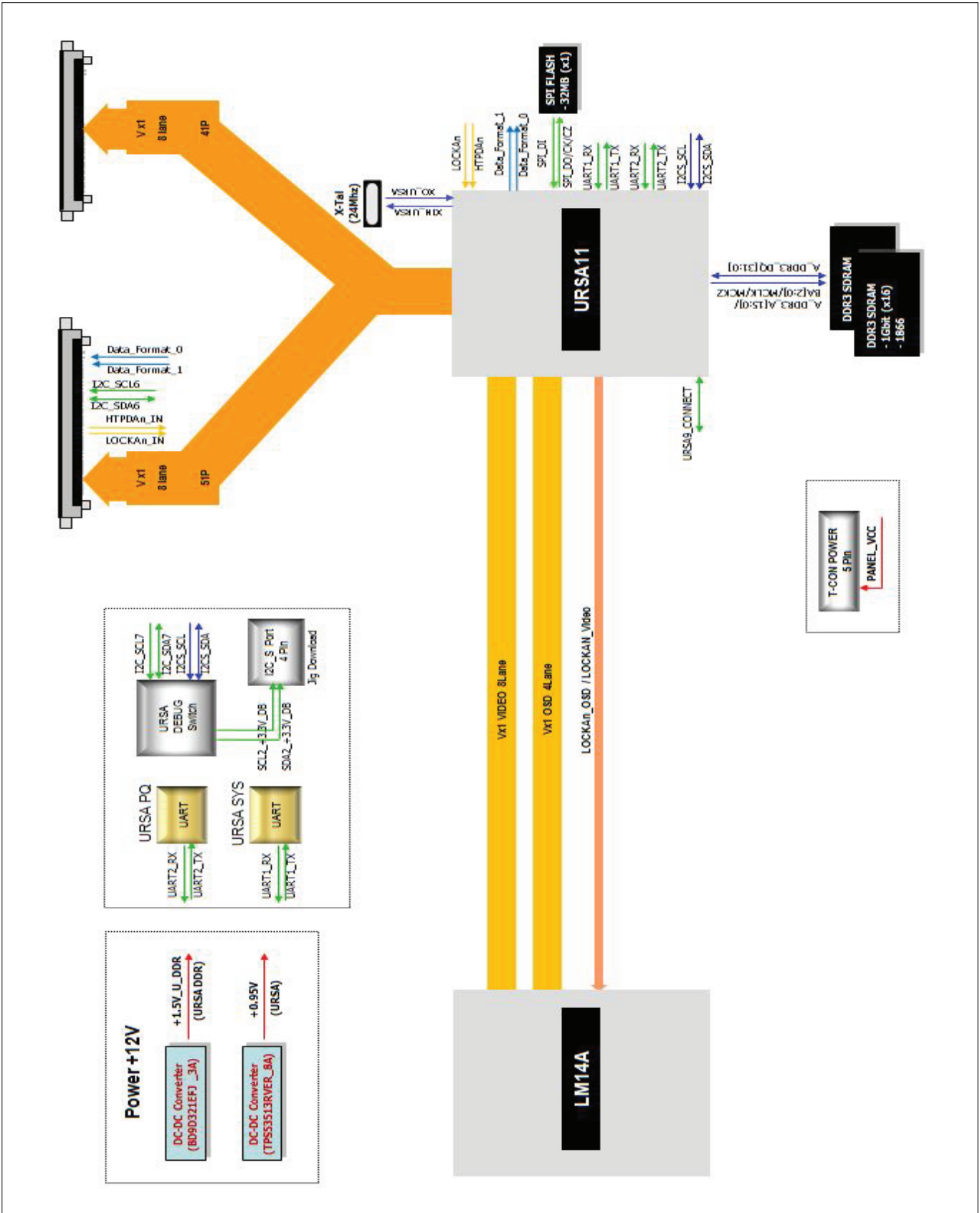

4. LM14A + URSA11 Power Block Diagram

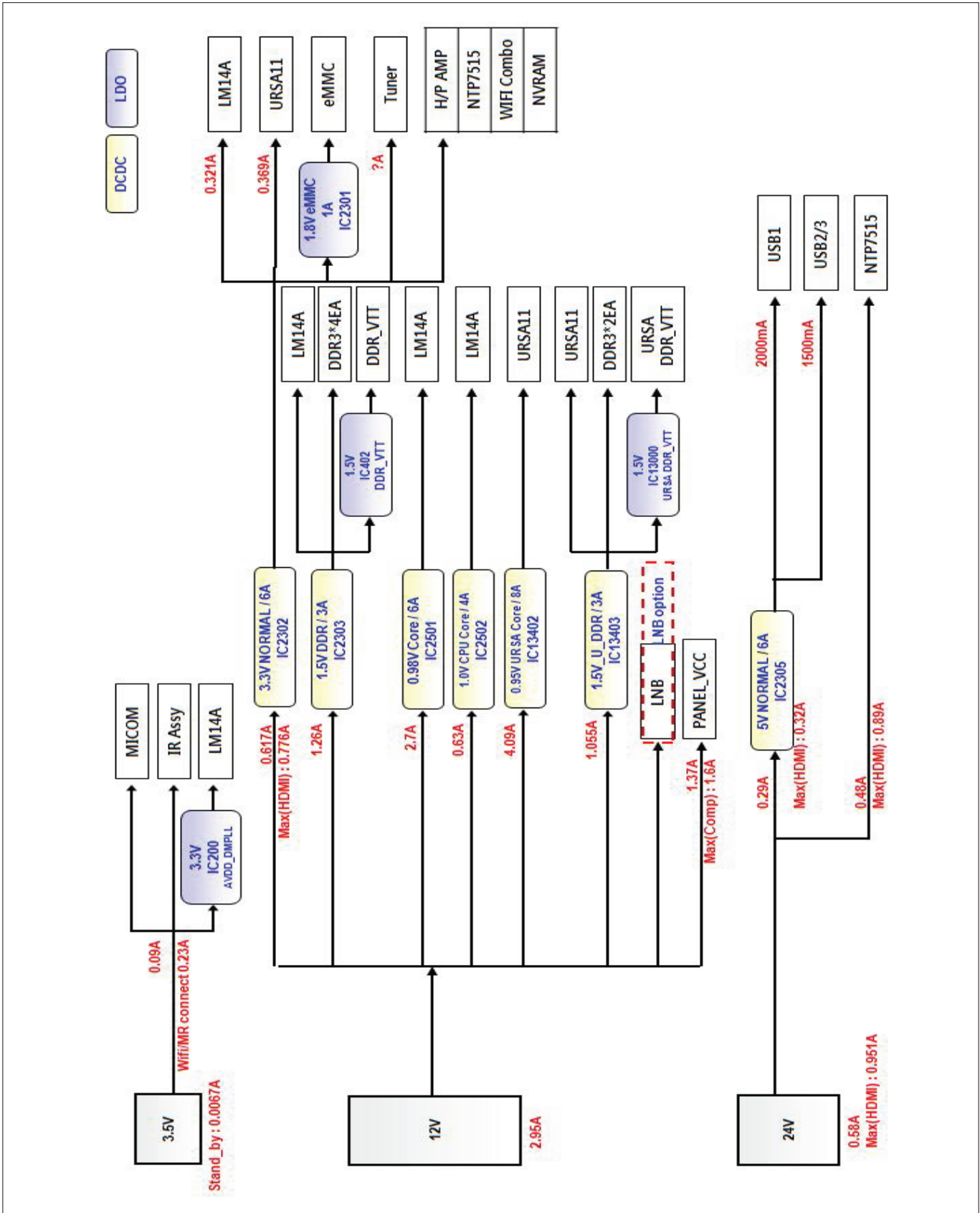

5. Tuner/CI Block Diagram

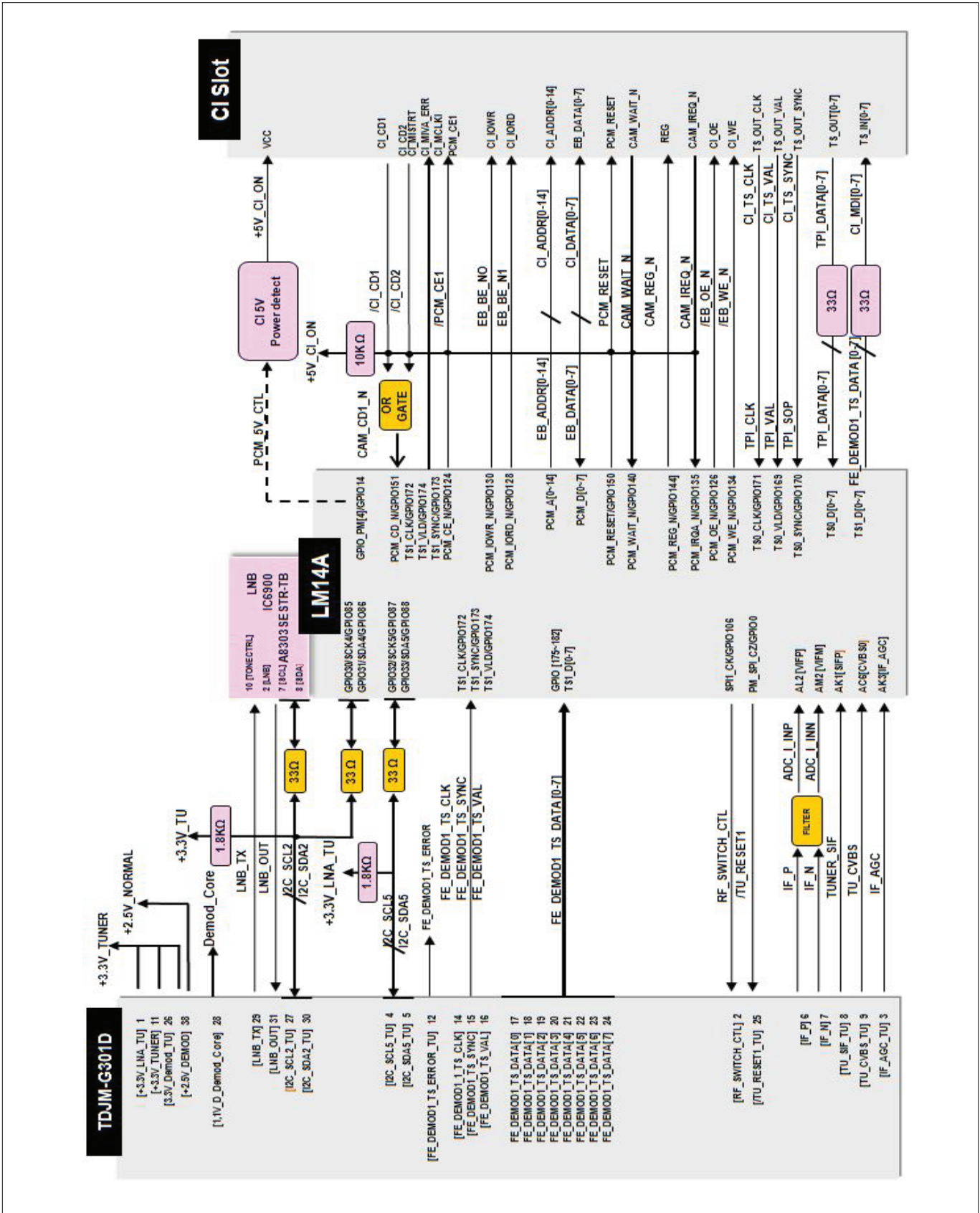

6. Video/Audio In Block Diagram

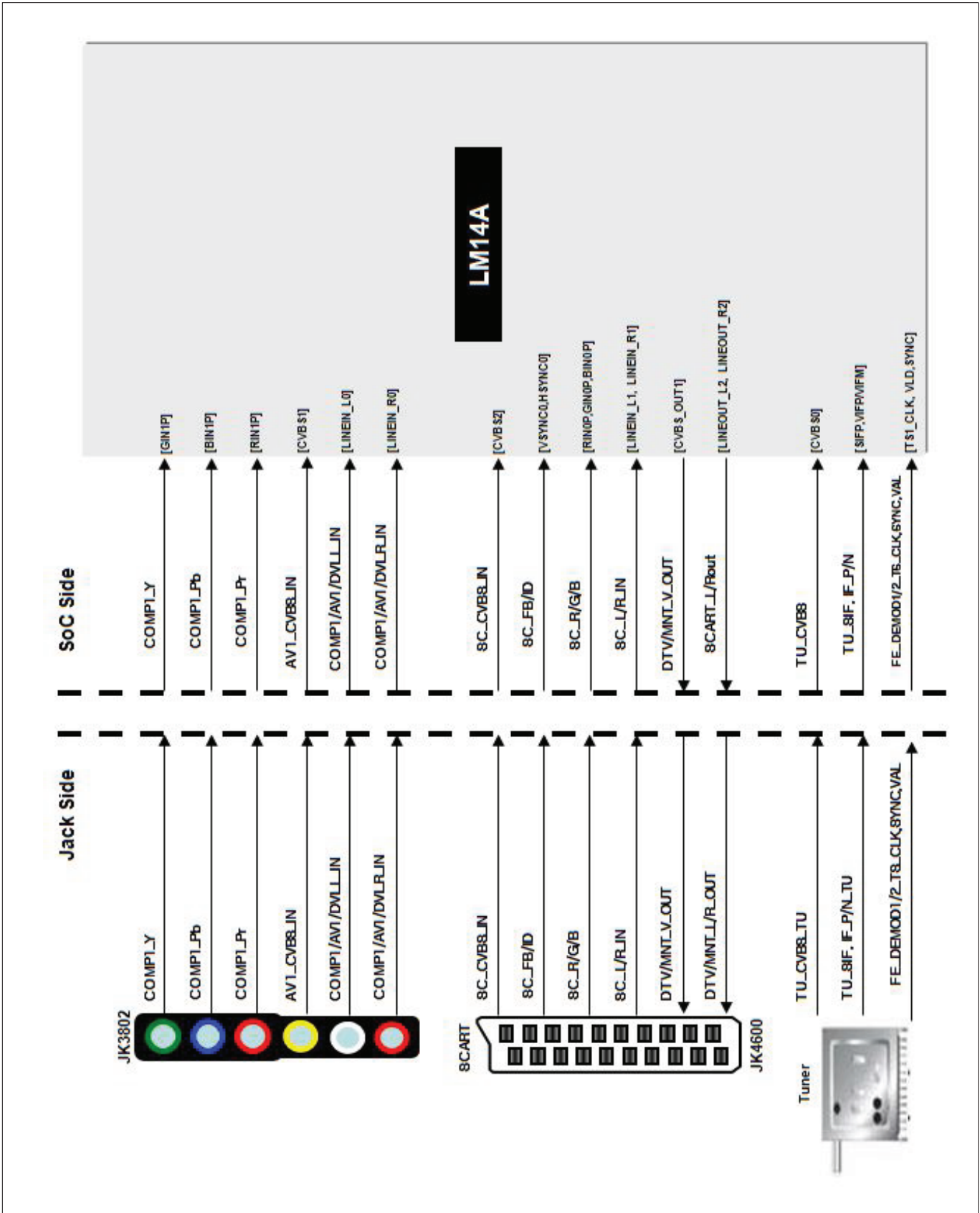

7. Audio Out Block Diagram

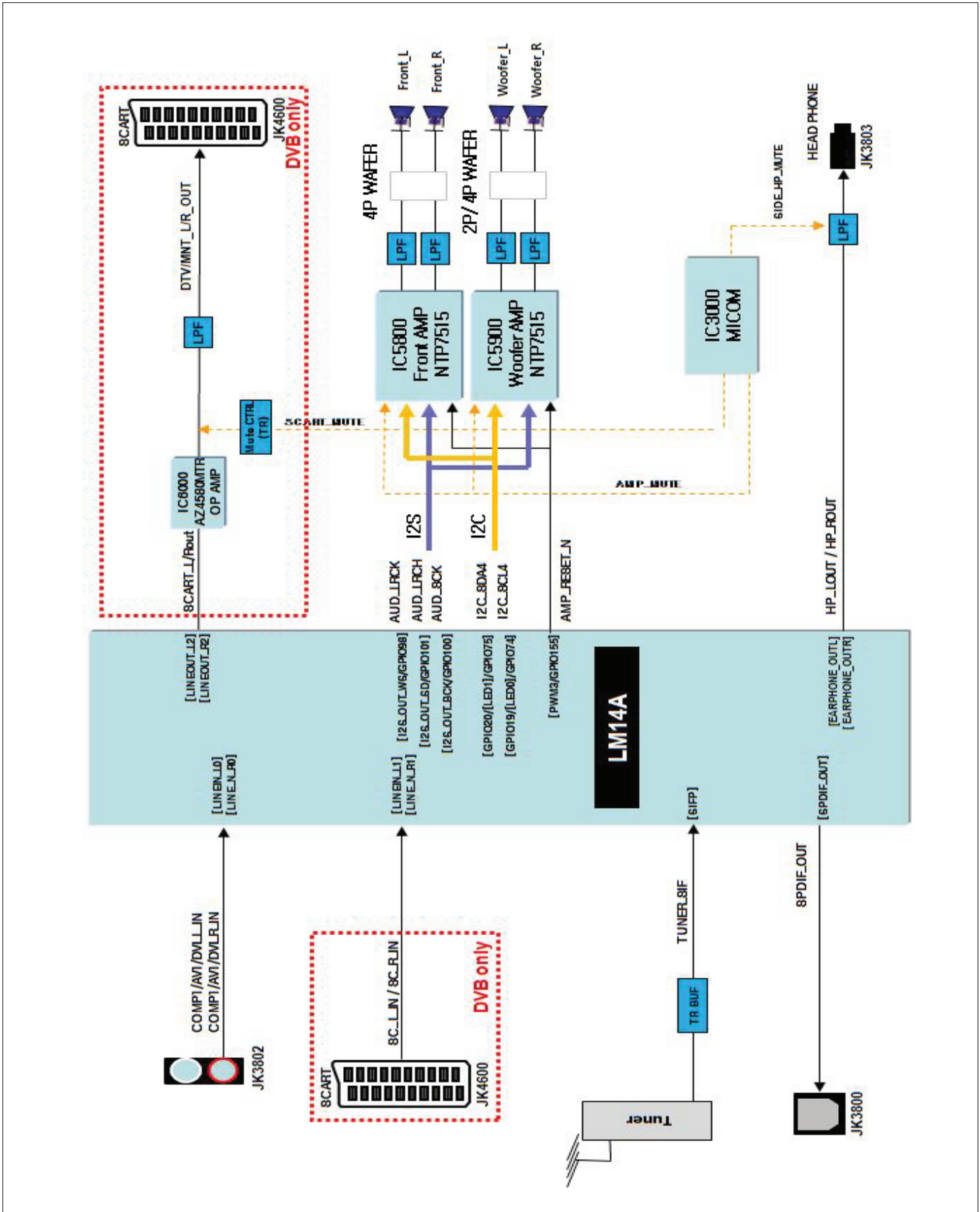

8. HDMI

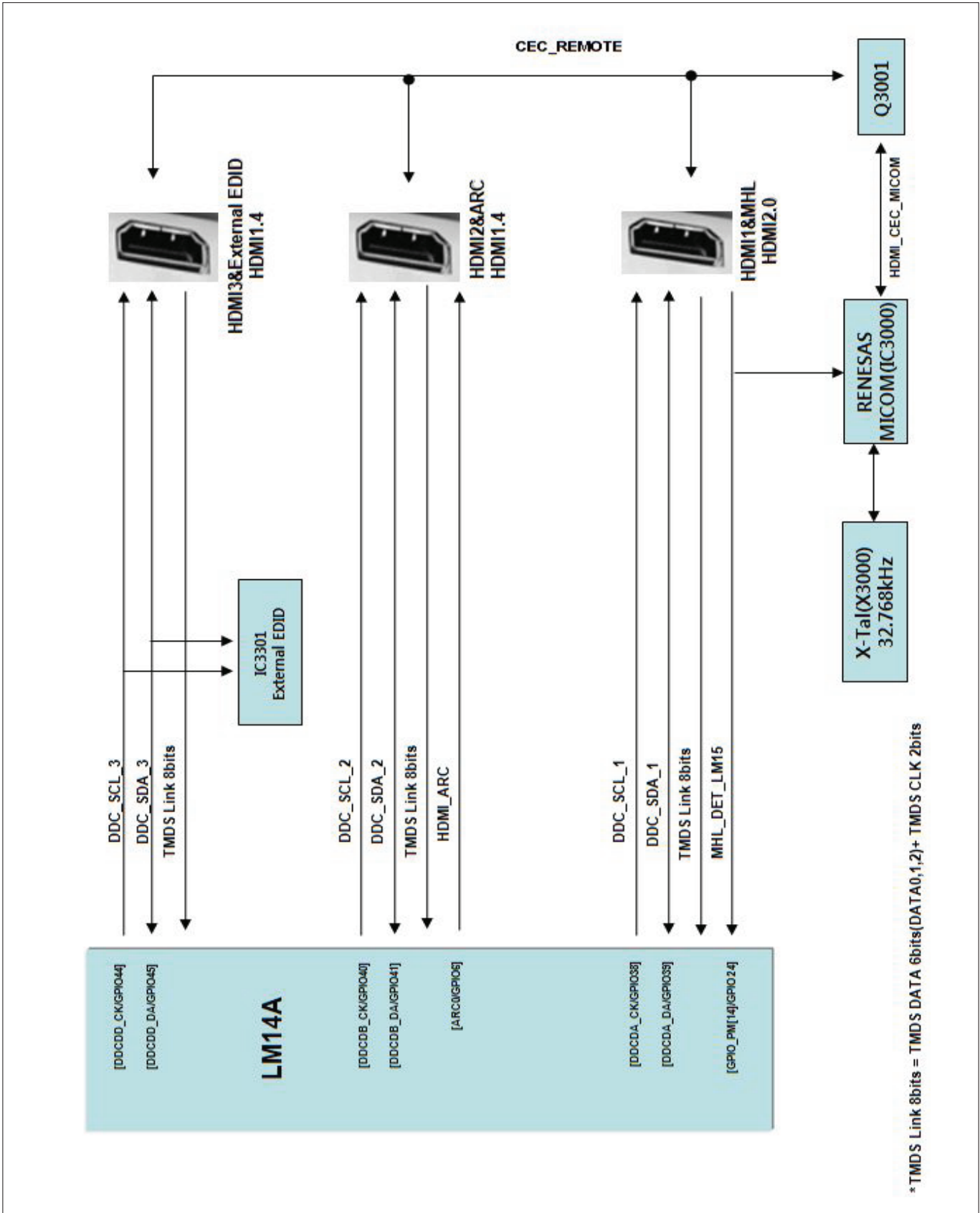

9. USB / WIFI / M-REMOTE / UART

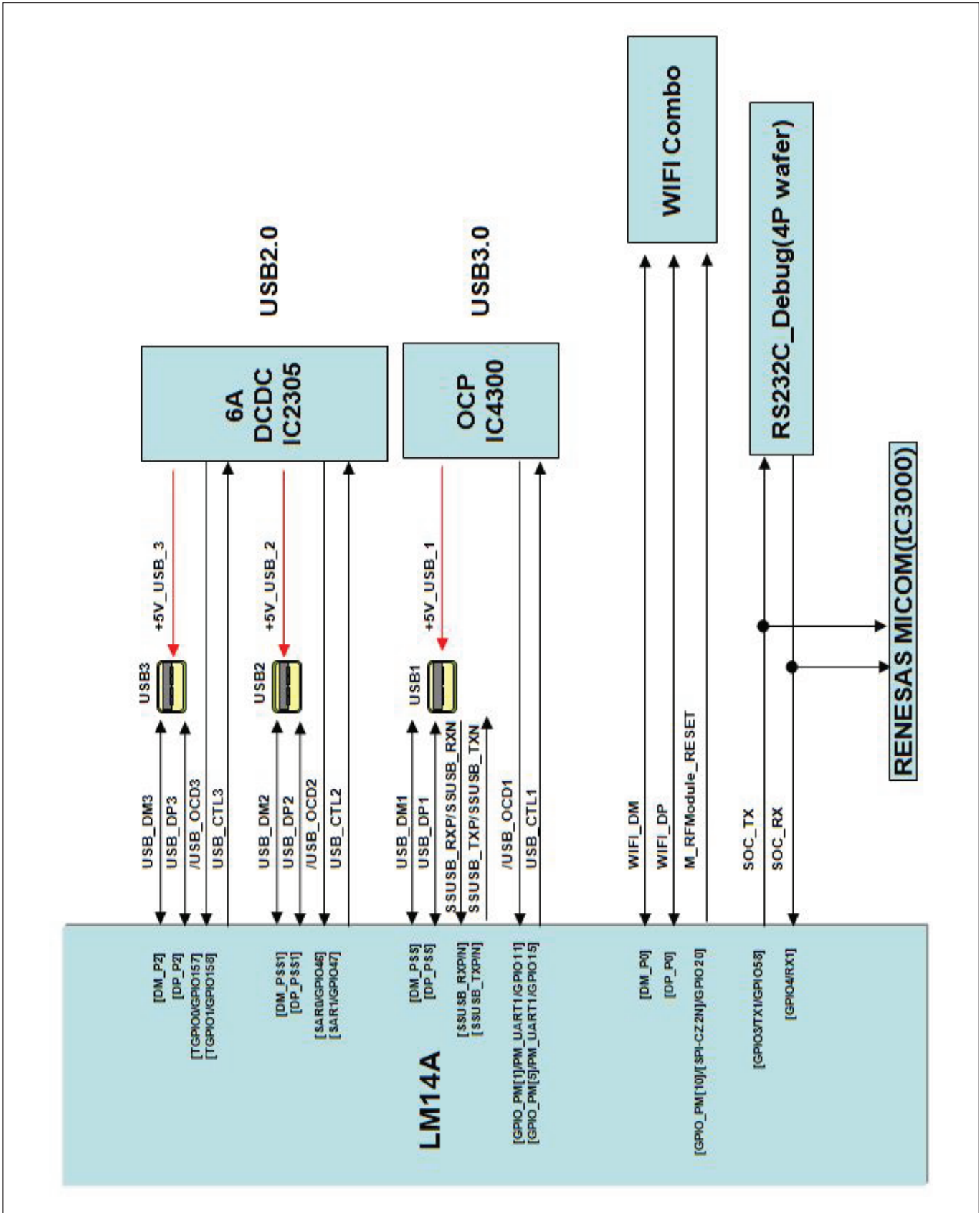

EXPLODED VIEW

IMPORTANT SAFETY NOTICE

Many electrical and mechanical parts in this chassis have special safety-related characteristics. These parts are identified by Δ in the Schematic Diagram and EXPLODED VIEW. It is essential that these special safety parts should be replaced with the same components as recommended in this manual to prevent Shock, Fire, or other Hazards. Do not modify the original design without permission of manufacturer.

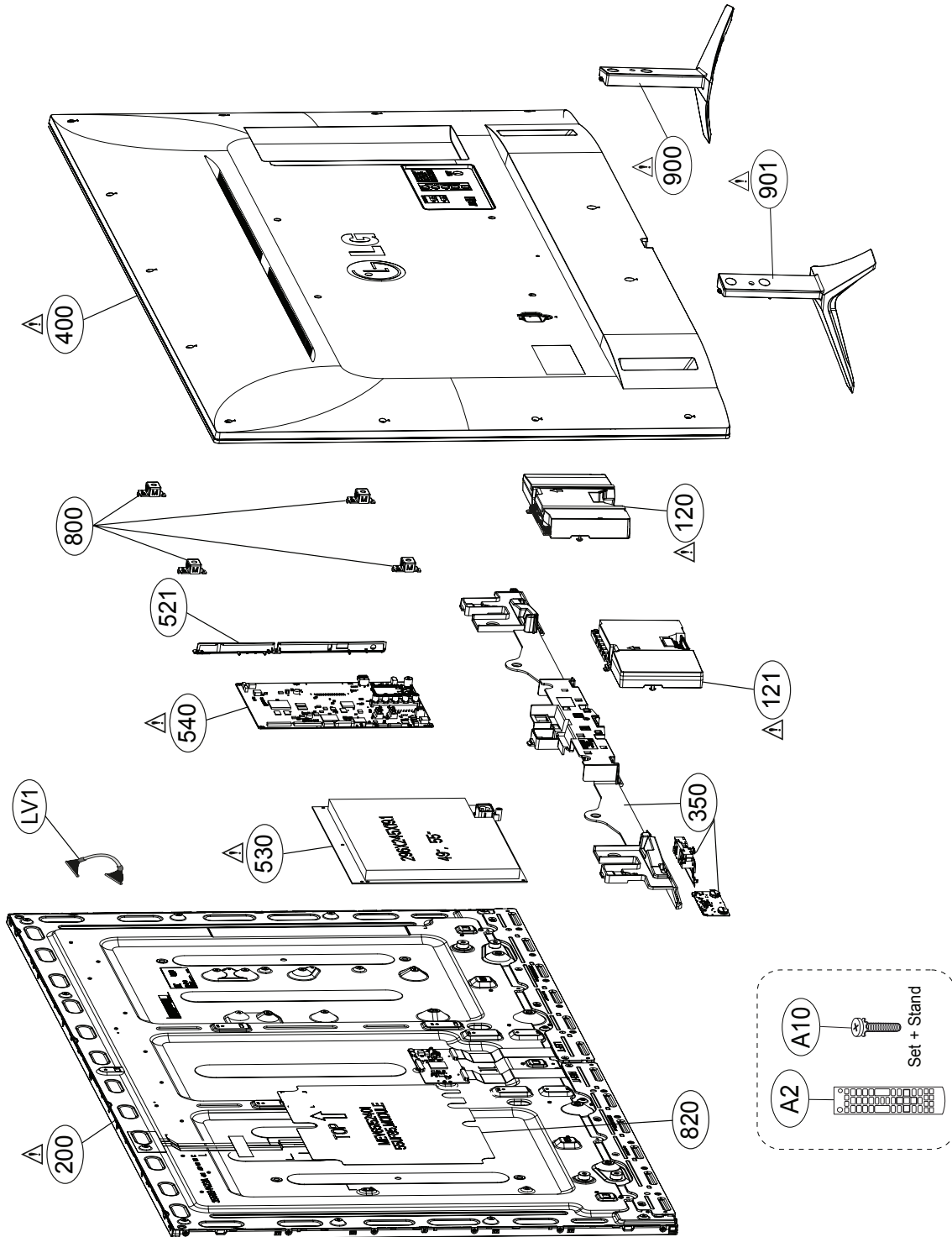

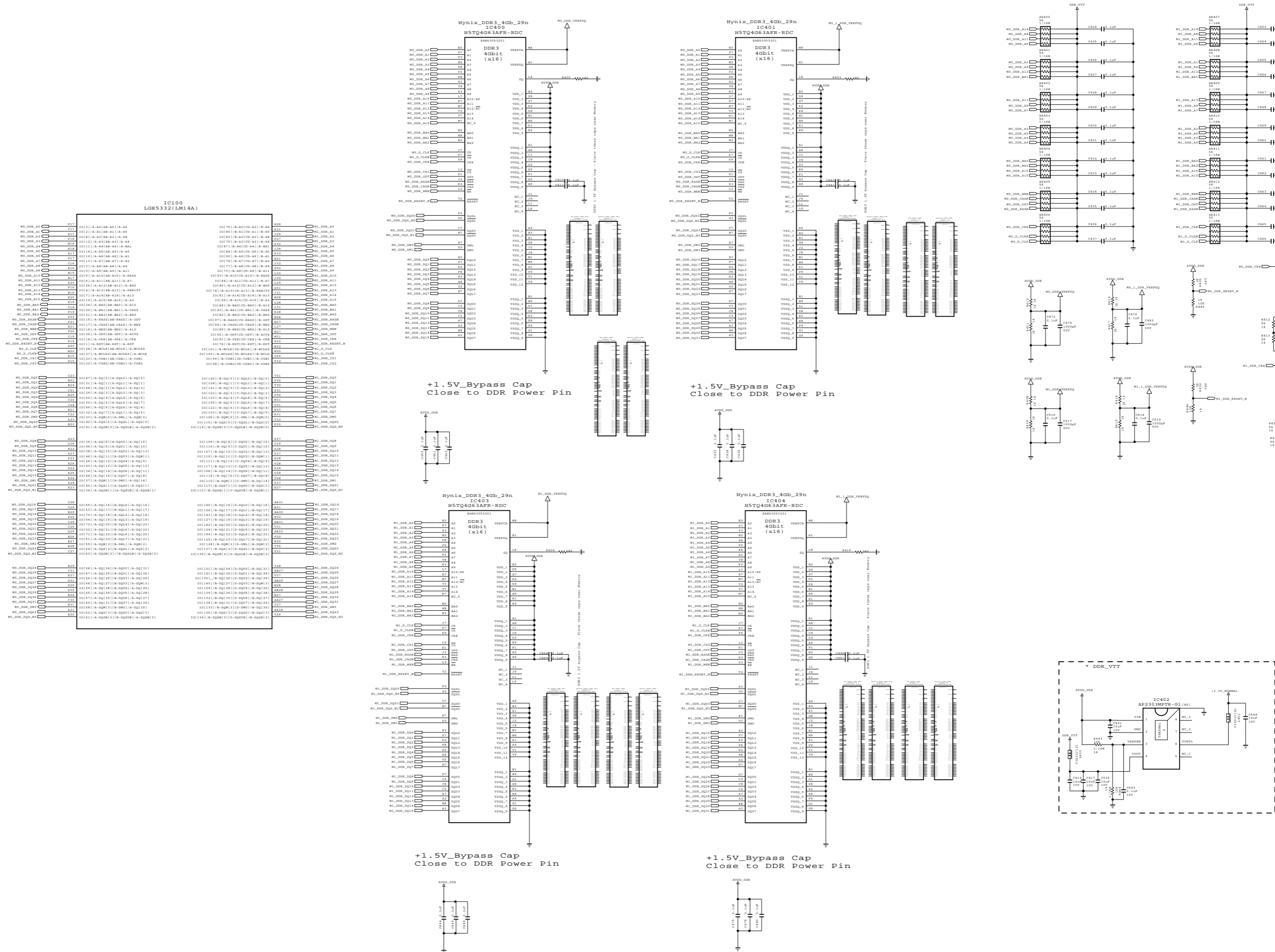

IC100
LGE5332(LM14A)

+1.5V_Bypass Cap
Close to DDR Power Pin

+1.5V_Bypass Cap
Close to DDR Power Pin

+1.5V_Bypass Cap
Close to DDR Power Pin

+1.5V_Bypass Cap
Close to DDR Power Pin

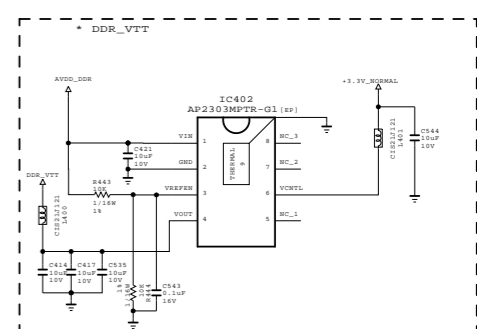

THE Δ SYMBOL MARK OF THIS SCHEMATIC DIAGRAM INCORPORATES SPECIAL FEATURES IMPORTANT FOR PROTECTION FROM X-RADIATION. FIRE AND ELECTRICAL SHOCK HAZARDS, WHEN SERVICING IF IS ESSENTIAL THAT ONLY MANUFACTURERS SPECIFIED PARTS BE USED FOR THE CRITICAL COMPONENTS IN THE Δ SYMBOL MARK OF THE SCHEMATIC.

SECRET
LGElectronics

LG ELECTRONICS

		BSD-15Y-LM14A-004_00-HD	
MODEL	LM14A	DATE	2014-12-30
BLOCK	LM14A DDR	SHEET	04

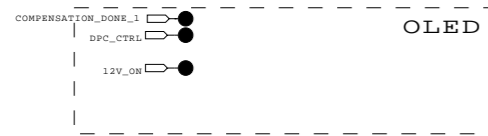

OLED

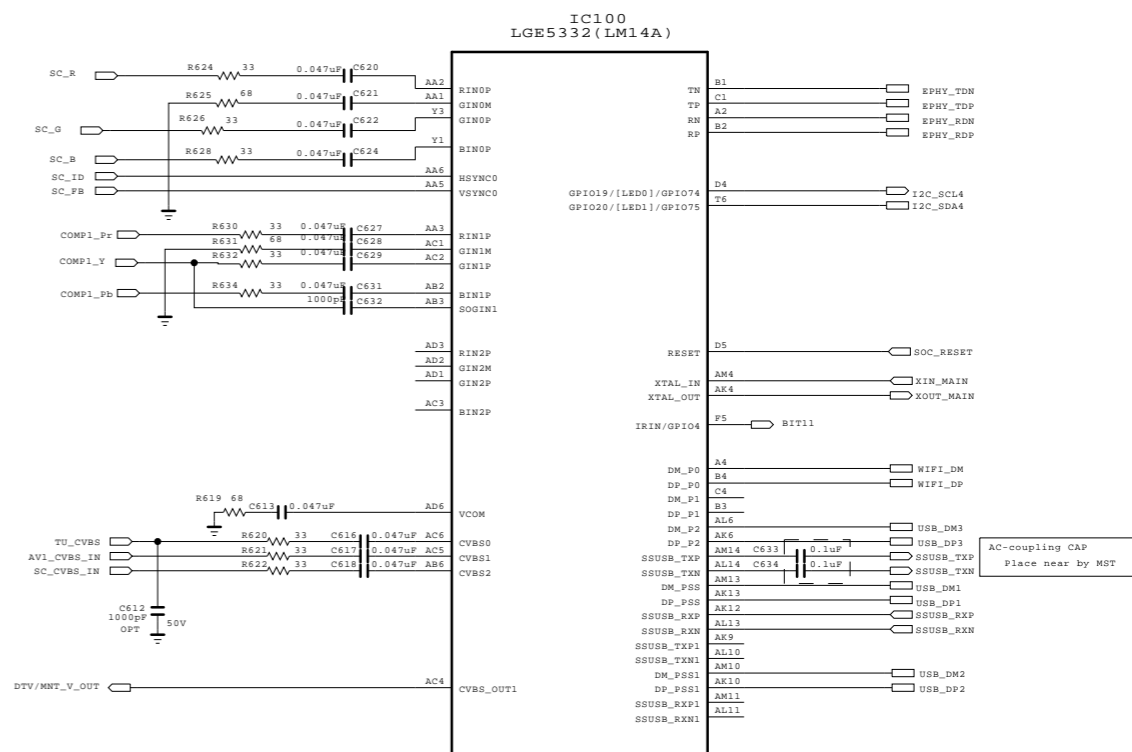
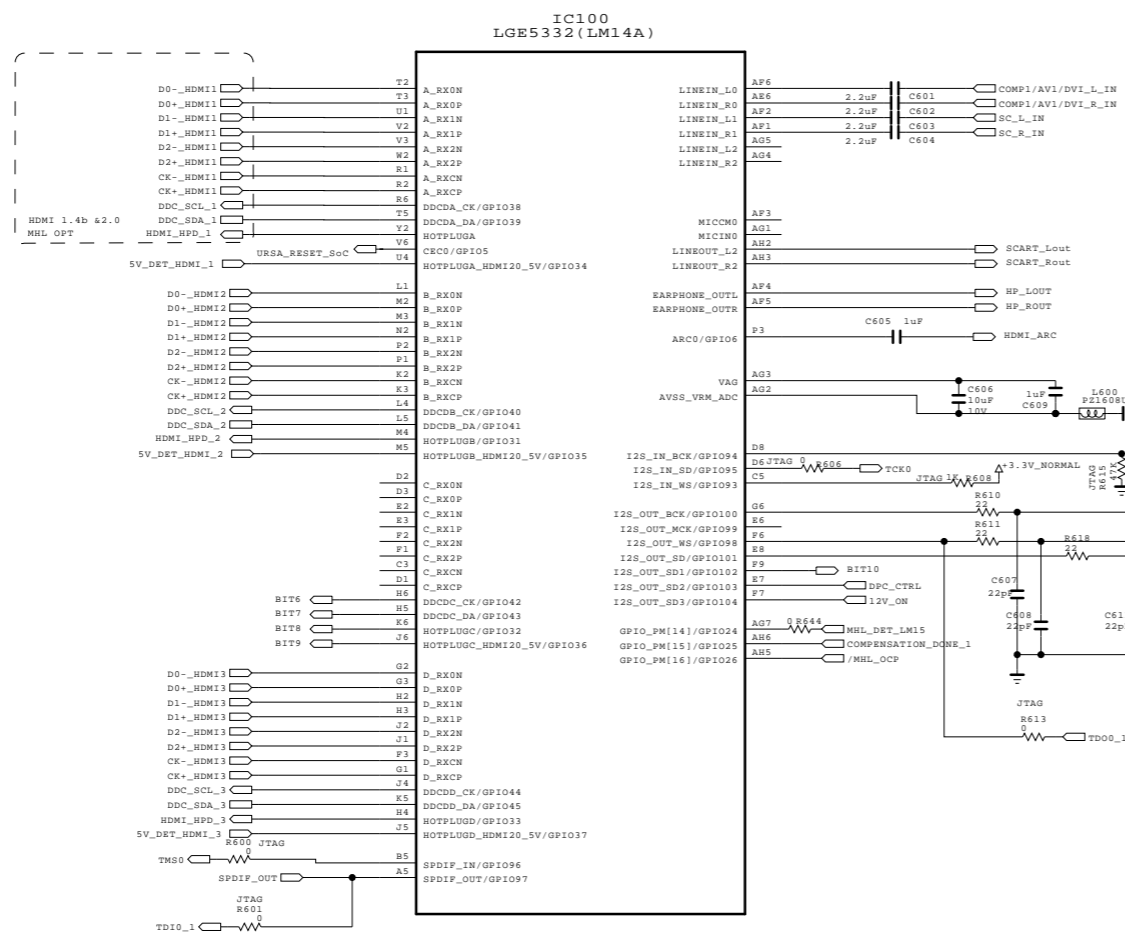
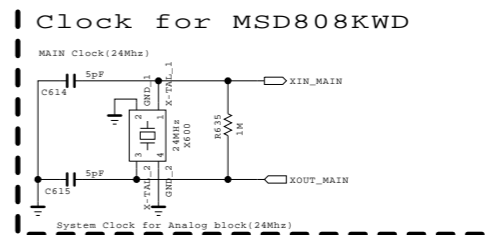
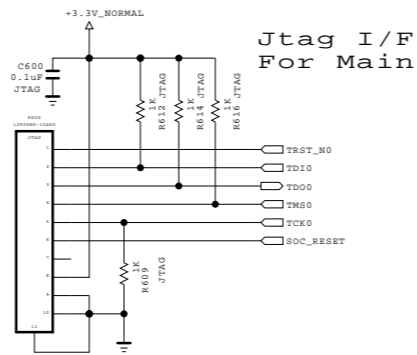
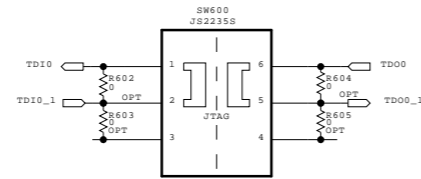

THE SYMBOL MARK OF THIS SCHEMATIC DIAGRAM INCORPORATES SPECIAL FEATURES IMPORTANT FOR PROTECTION FROM X-RADIATION. FIRE AND ELECTRICAL SHOCK HAZARDS, WHEN SERVICING IF IS ESSENTIAL THAT ONLY MANUFACTURES SPECIFIED PARTS BE USED FOR THE CRITICAL COMPONENTS IN THE SYMBOL MARK OF THE SCHEMATIC.

SECRET
LGElectronics



BSD-15Y-LM14A-006_00-HD			
MODEL	LM14A	DATE	2015-01-08
BLOCK	MAIN4_EXT_IN/OUTPUT	SHEET	06

IC100
LGS5332 (LM14A)

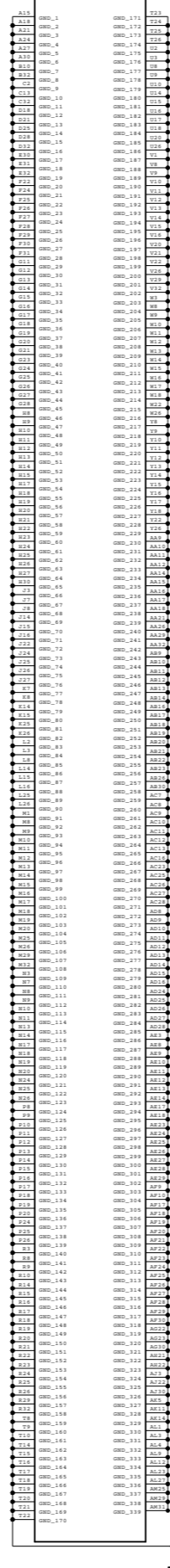

THE SYMBOL MARK OF THIS SCHEMATIC DIAGRAM INCORPORATES SPECIAL FEATURES IMPORTANT FOR PROTECTION FROM X-RADIATION. FIRE AND ELECTRICAL SHOCK HAZARDS, WHEN SERVICING IF IS ESSENTIAL THAT ONLY MANUFACTURERS SPECIFIED PARTS BE USED FOR THE CRITICAL COMPONENTS IN THE SYMBOL MARK OF THE SCHEMATIC.

SECRET
LGElectronics



BSD-15Y-LM14A-007_00-HD			
MODEL	LM14A	DATE	2014-11-13
BLOCK	LM14A_GND	SHEET	07

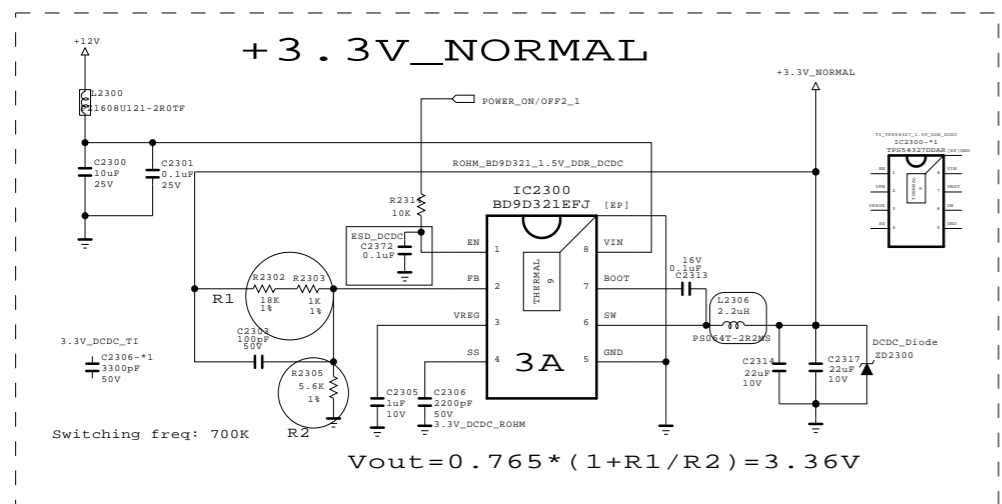
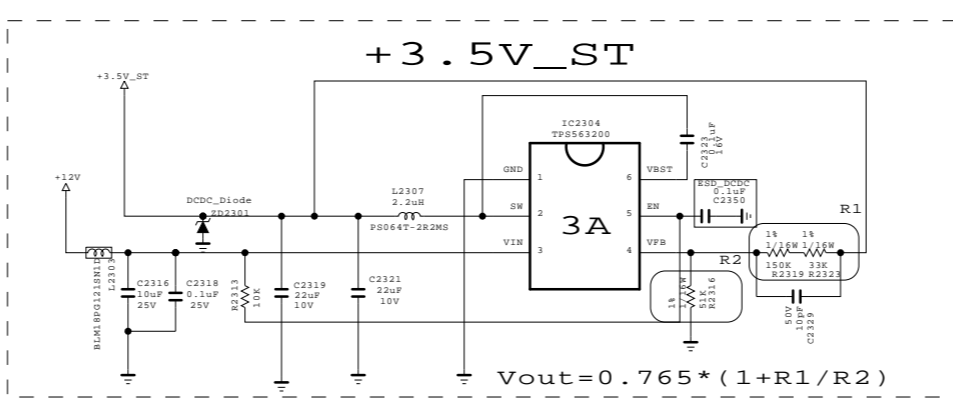
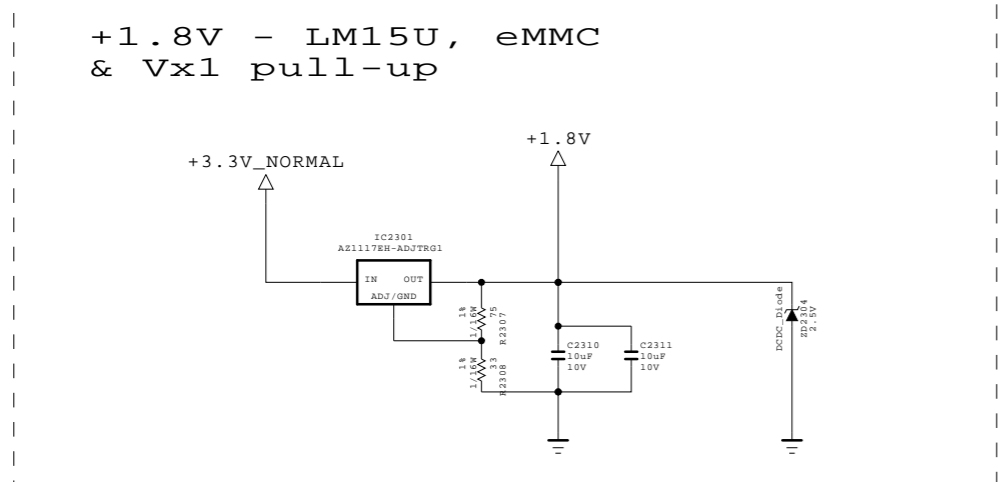
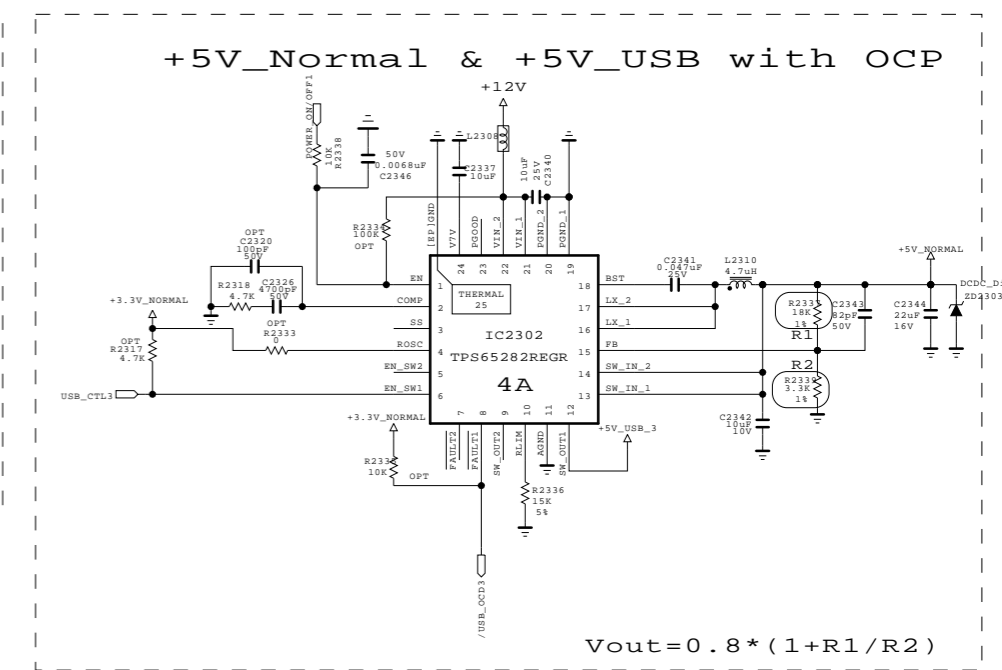
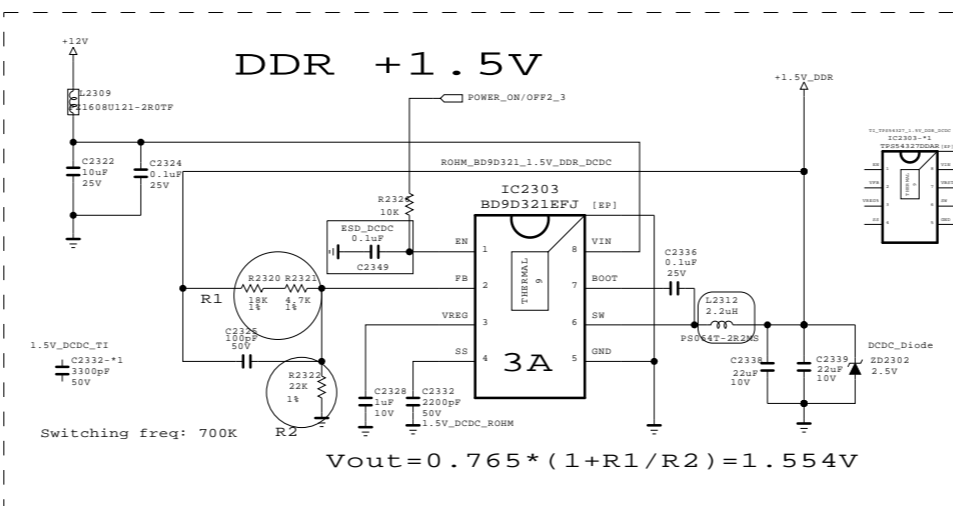
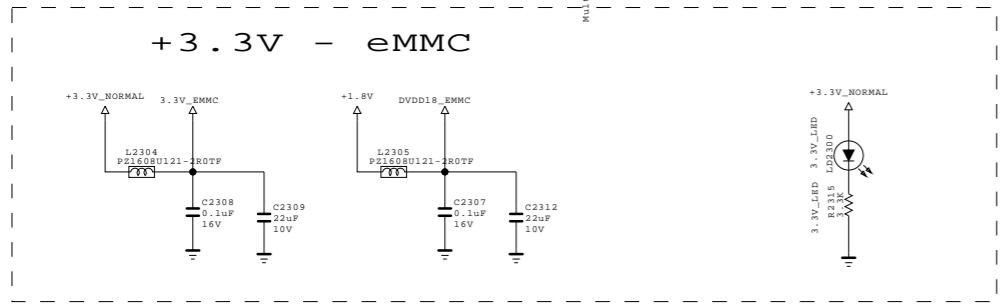
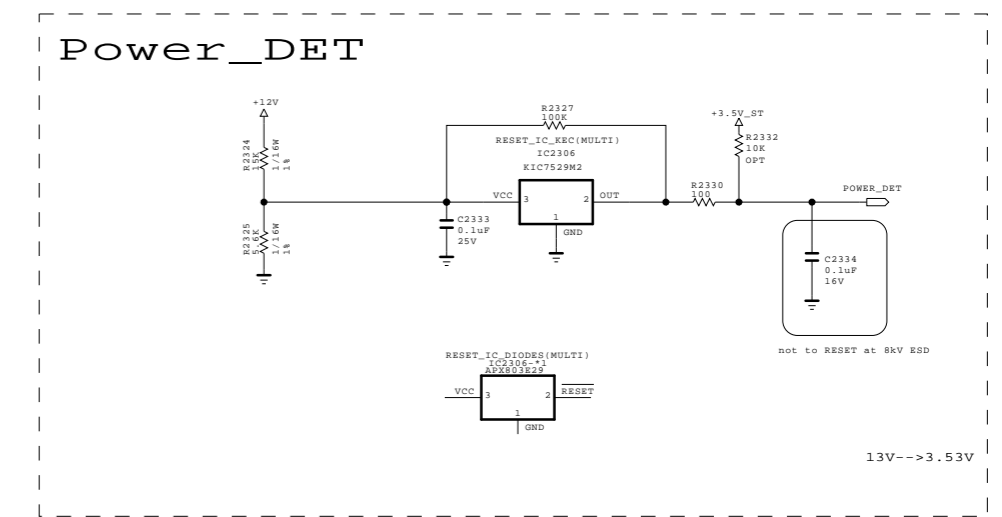
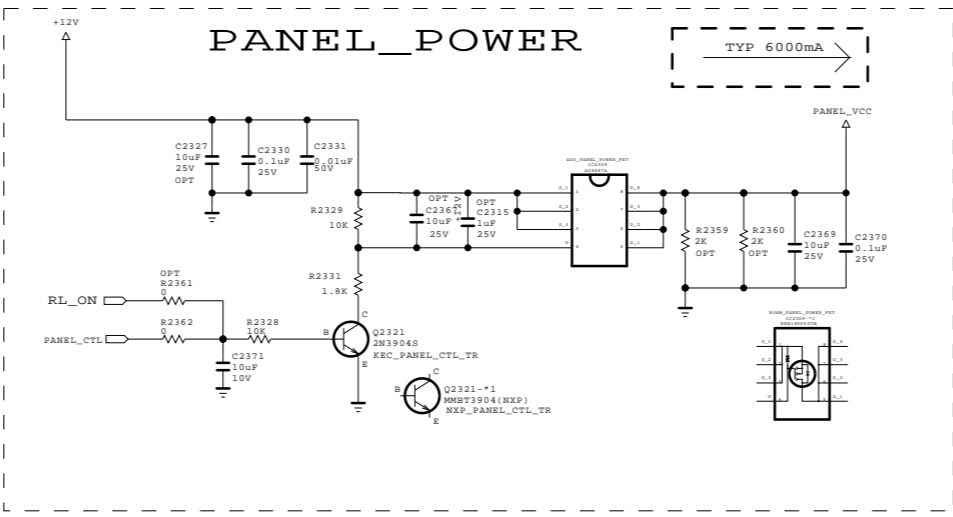
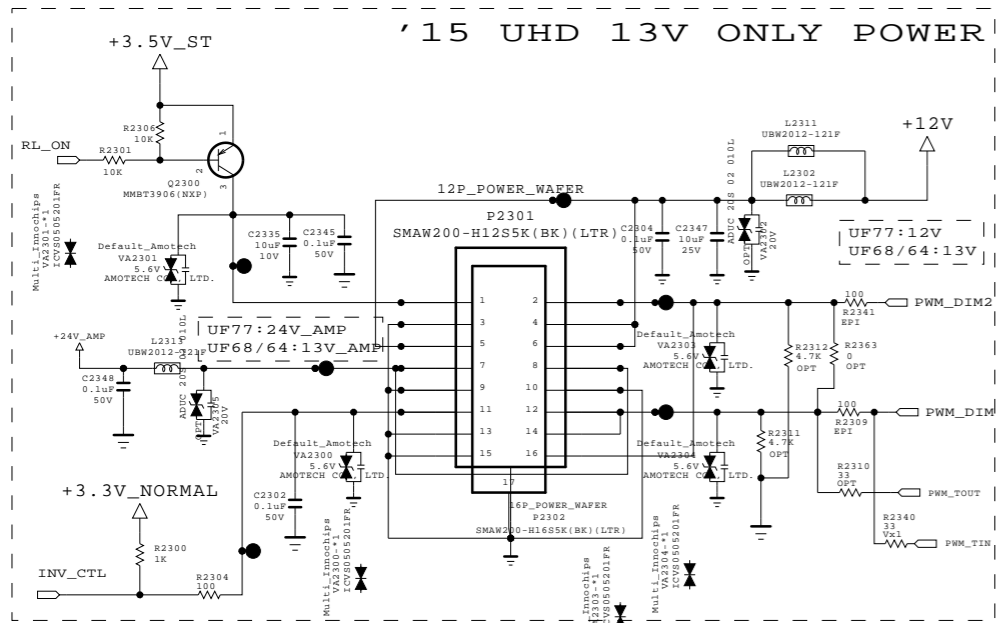

LM15 Power SEQUENCE

- POWER_ON/OFF1 (5V)
- ↓
- POWER_ON/OFF2_1 (3.3V)
- ↓
- POWER_ON/OFF2_3 (1.5V)
- ↓
- POWER_ON/OFF2_4 (1.1V)

THE SYMBOL MARK OF THIS SCHEMATIC DIAGRAM INCORPORATES SPECIAL FEATURES IMPORTANT FOR PROTECTION FROM X-RADIATION. FIRE AND ELECTRICAL SHOCK HAZARDS, WHEN SERVICING IF IS ESSENTIAL THAT ONLY MANUFACTURES SPECIFIED PARTS BE USED FOR THE CRITICAL COMPONENTS IN THE SYMBOL MARK OF THE SCHEMATIC.

SECRET
LGElectronics



MODEL	LM14A (UF68/UF64)	DATE	2015-01-23
BLOCK	LM14A_PWR_1_13V_only	SHEET	23

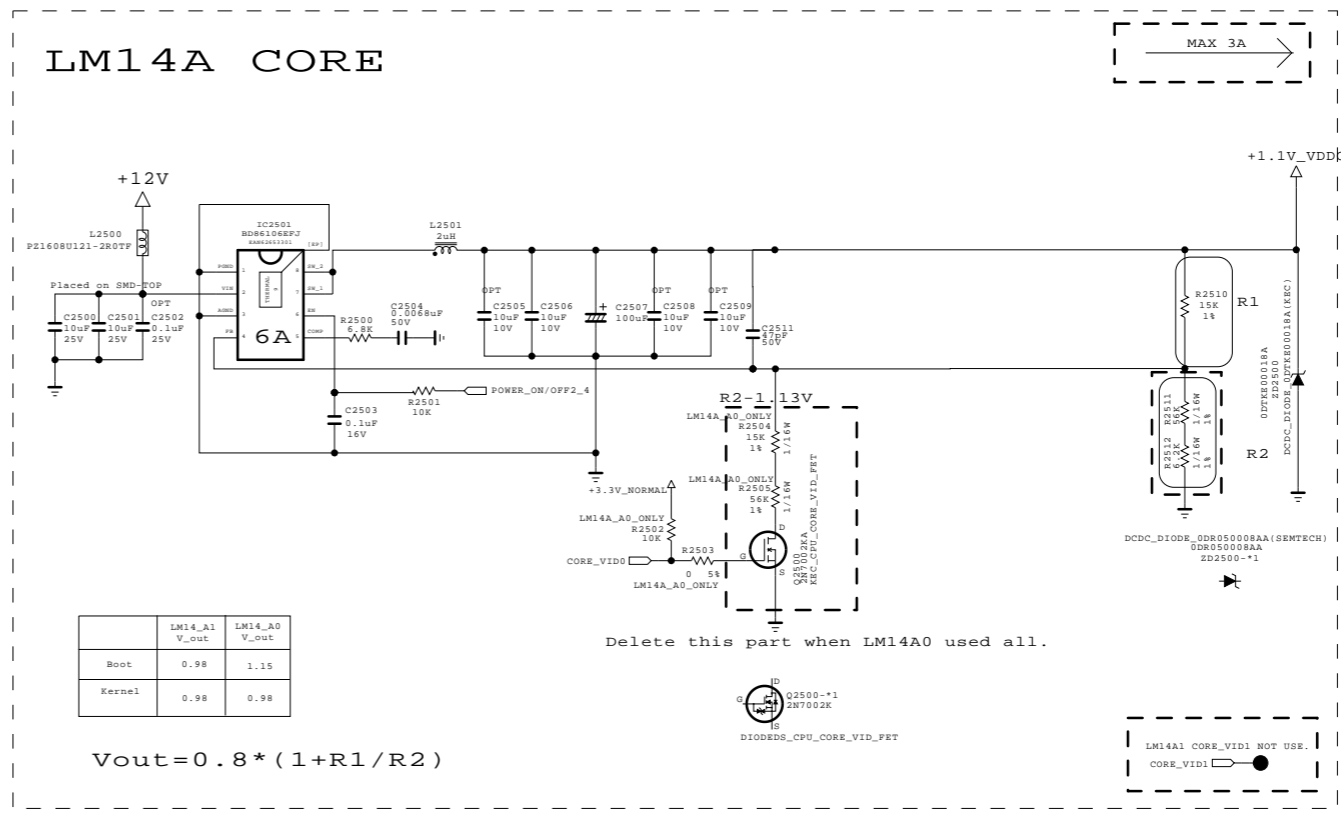
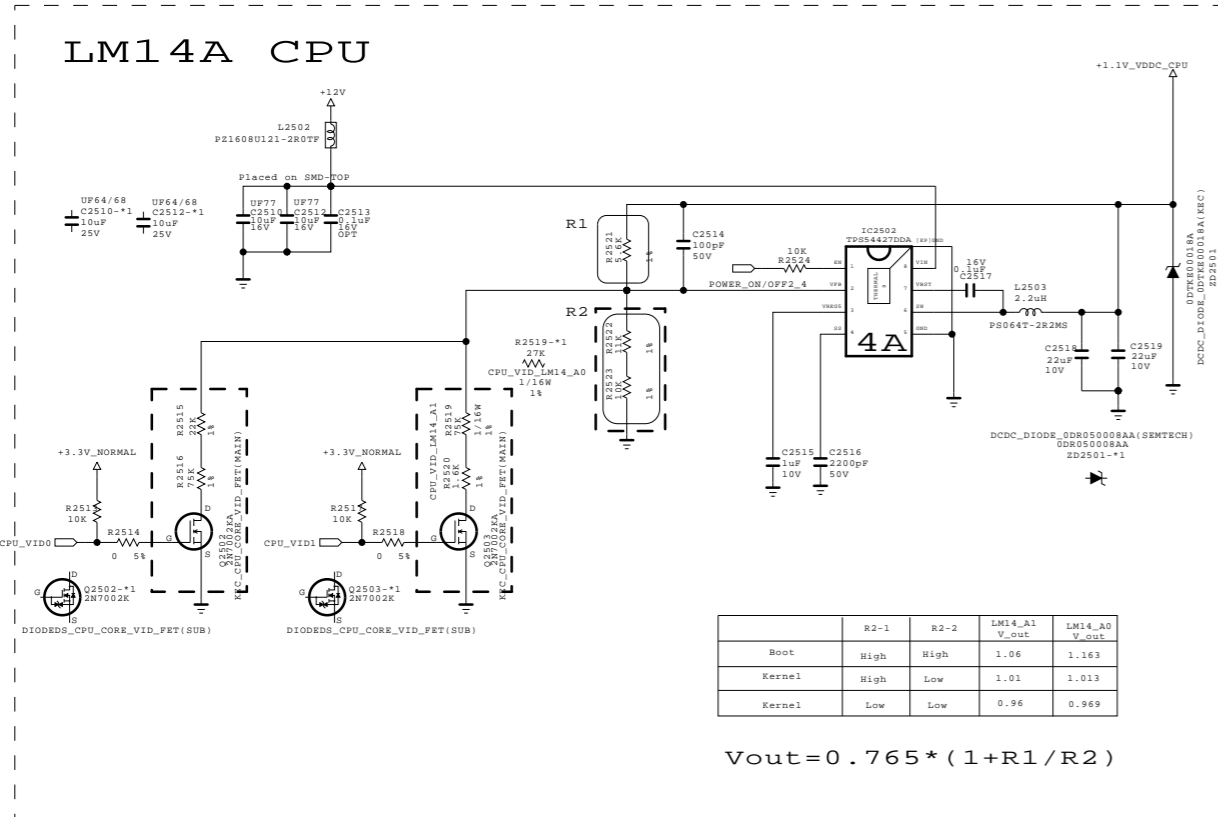

THE Δ SYMBOL MARK OF THIS SCHEMATIC DIAGRAM INCORPORATES SPECIAL FEATURES IMPORTANT FOR PROTECTION FROM X-RADIATION. FIRE AND ELECTRICAL SHOCK HAZARDS, WHEN SERVICING IF IS ESSENTIAL THAT ONLY MANUFACTURES SPECIFIED PARTS BE USED FOR THE CRITICAL COMPONENTS IN THE Δ SYMBOL MARK OF THE SCHEMATIC.

SECRET
LGElectronics



BSD-15Y-LM14A-025_00-HD

MODEL	LM14A	DATE	2015-01-21
BLOCK	LM15U_PWR_2_ALL	SHEET	25

Renesas MICOM

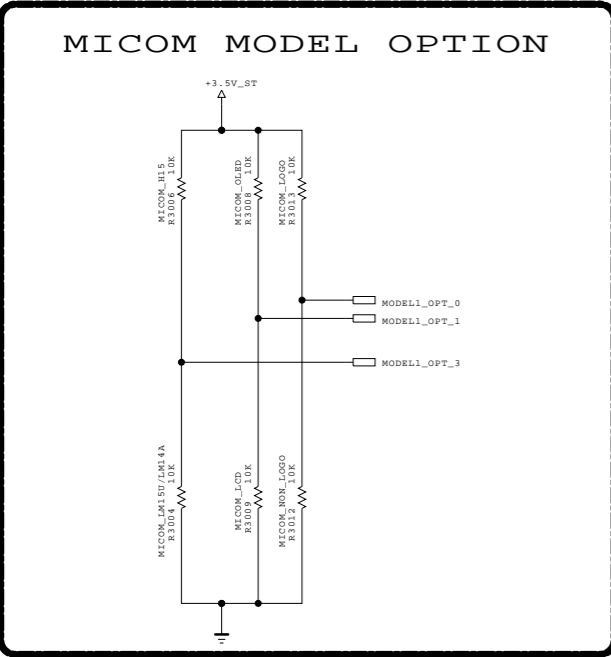
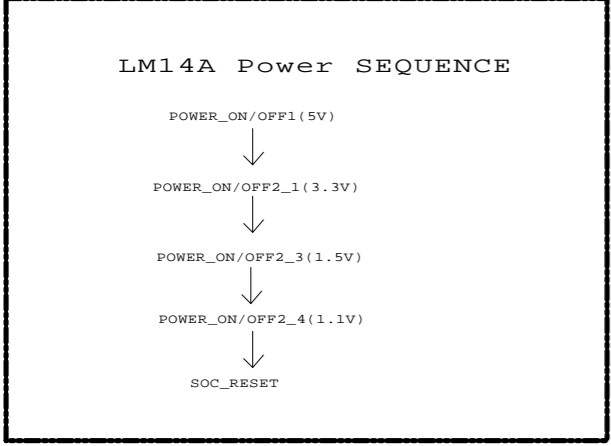
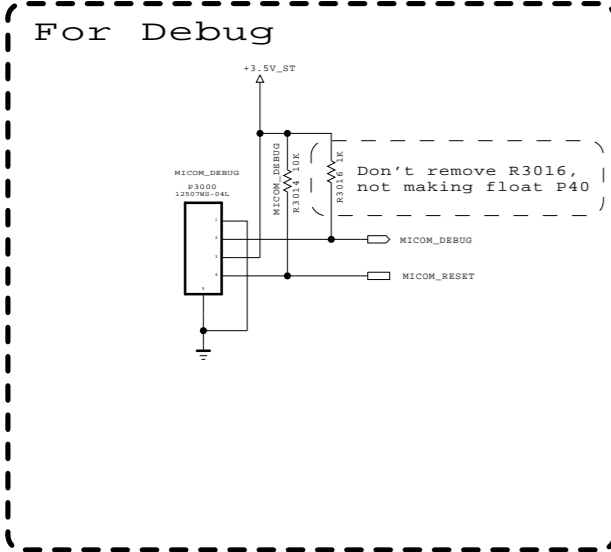

MICOM MODEL OPTION

	0	1
MODEL_OPT_0	NON LOGO	LOGO
MODEL_OPT_1	LCD	OLED
MODEL_OPT_3	LM15U/LM14A	H15

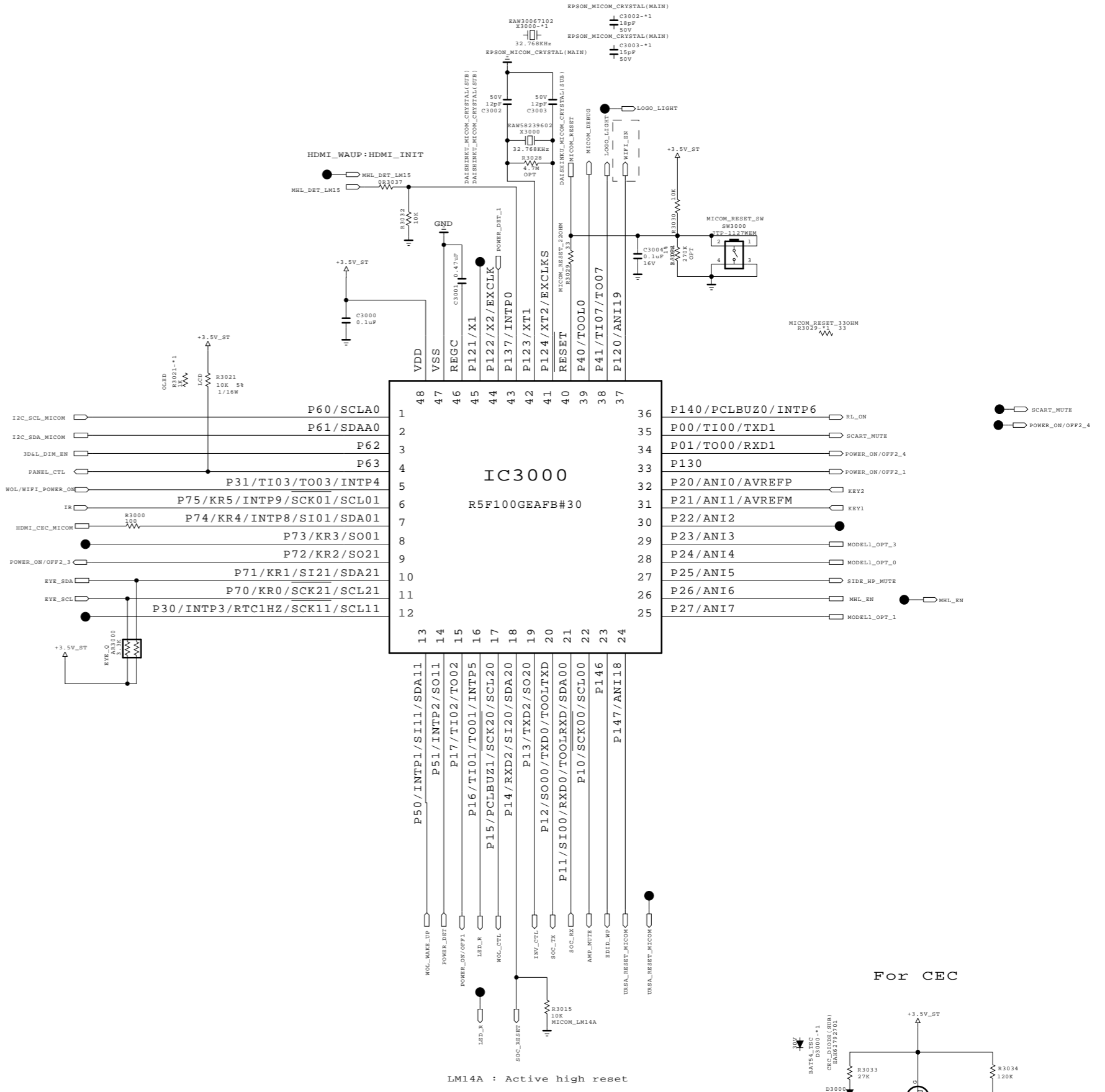

For CEC

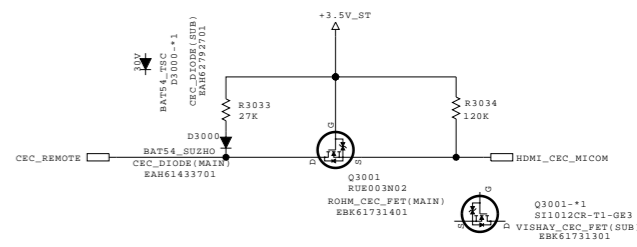

THE SYMBOL MARK OF THIS SCHEMATIC DIAGRAM INCORPORATES SPECIAL FEATURES IMPORTANT FOR PROTECTION FROM X-RADIATION. FIRE AND ELECTRICAL SHOCK HAZARDS, WHEN SERVICING IF IS ESSENTIAL THAT ONLY MANUFACTURES SPECIFIED PARTS BE USED FOR THE CRITICAL COMPONENTS IN THE SYMBOL MARK OF THE SCHEMATIC.

SECRET
LGElectronics



MODEL	LM14A	DATE	2015-01-21
BLOCK	MICOM	SHEET	30

HDMI 3 INPUT (Rear Horizontal)

Different from the sheet specification and description
 Sheet spec. and description : HDMI_Rear2_Side1

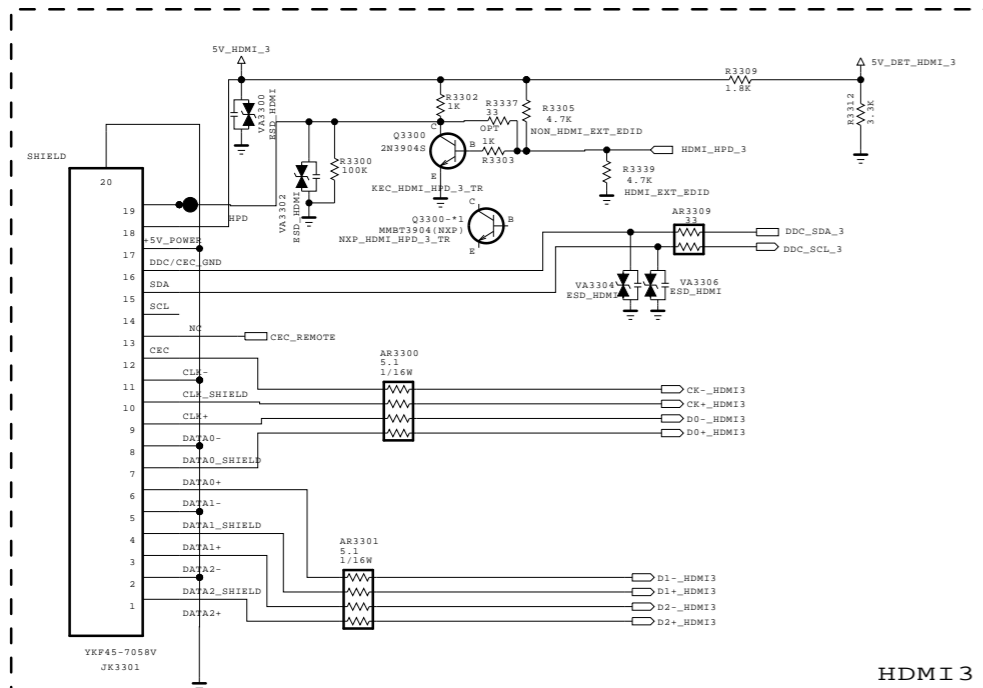

HDMI 3

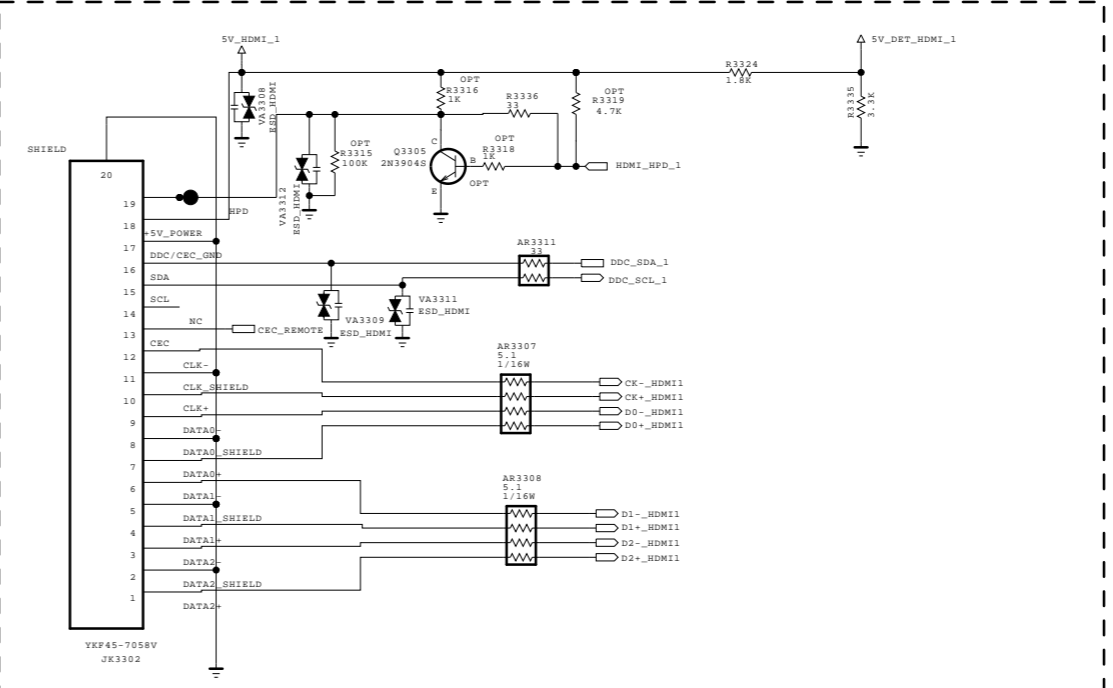

HDMI 1 (6G)

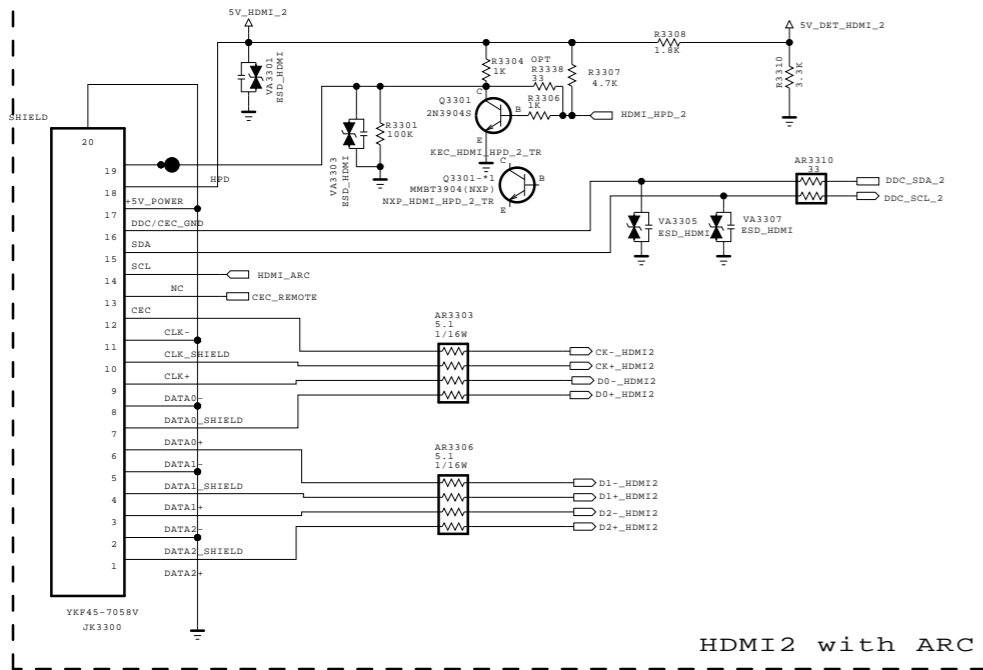

HDMI 2 with ARC

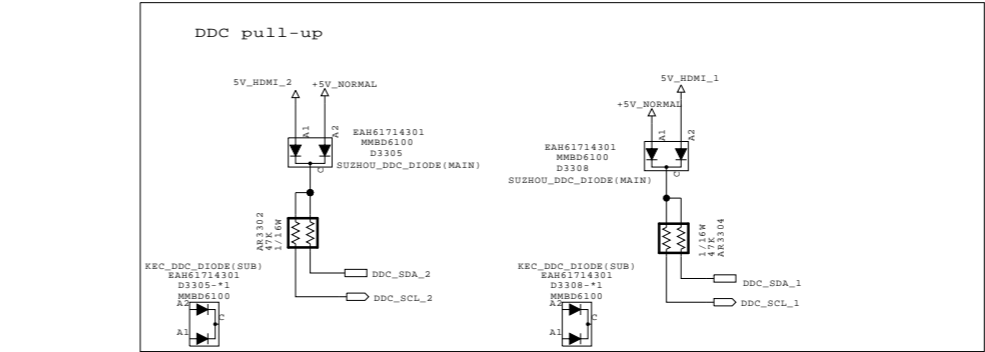
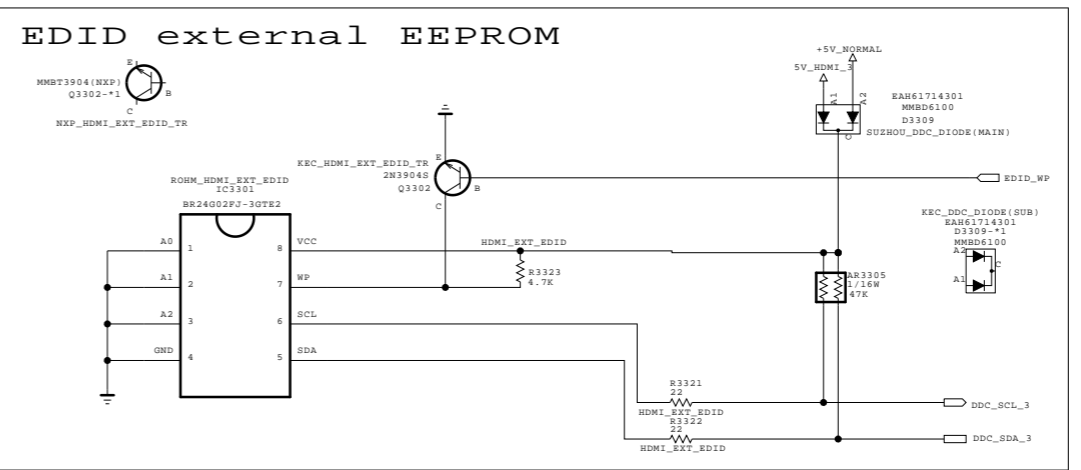

THE SYMBOL MARK OF THIS SCHEMATIC DIAGRAM INCORPORATES SPECIAL FEATURES IMPORTANT FOR PROTECTION FROM X-RADIATION. FIRE AND ELECTRICAL SHOCK HAZARDS, WHEN SERVICING IF IS ESSENTIAL THAT ONLY MANUFACTURES SPECIFIED PARTS BE USED FOR THE CRITICAL COMPONENTS IN THE SYMBOL MARK OF THE SCHEMATIC.

SECRET
 LG Electronics



MODEL	LM14A	DATE	2015-02-06
BLOCK	HDMI_REAR_3 INPUT	SHEET	033_04

BSD-15Y-LM14A-033_04-HD

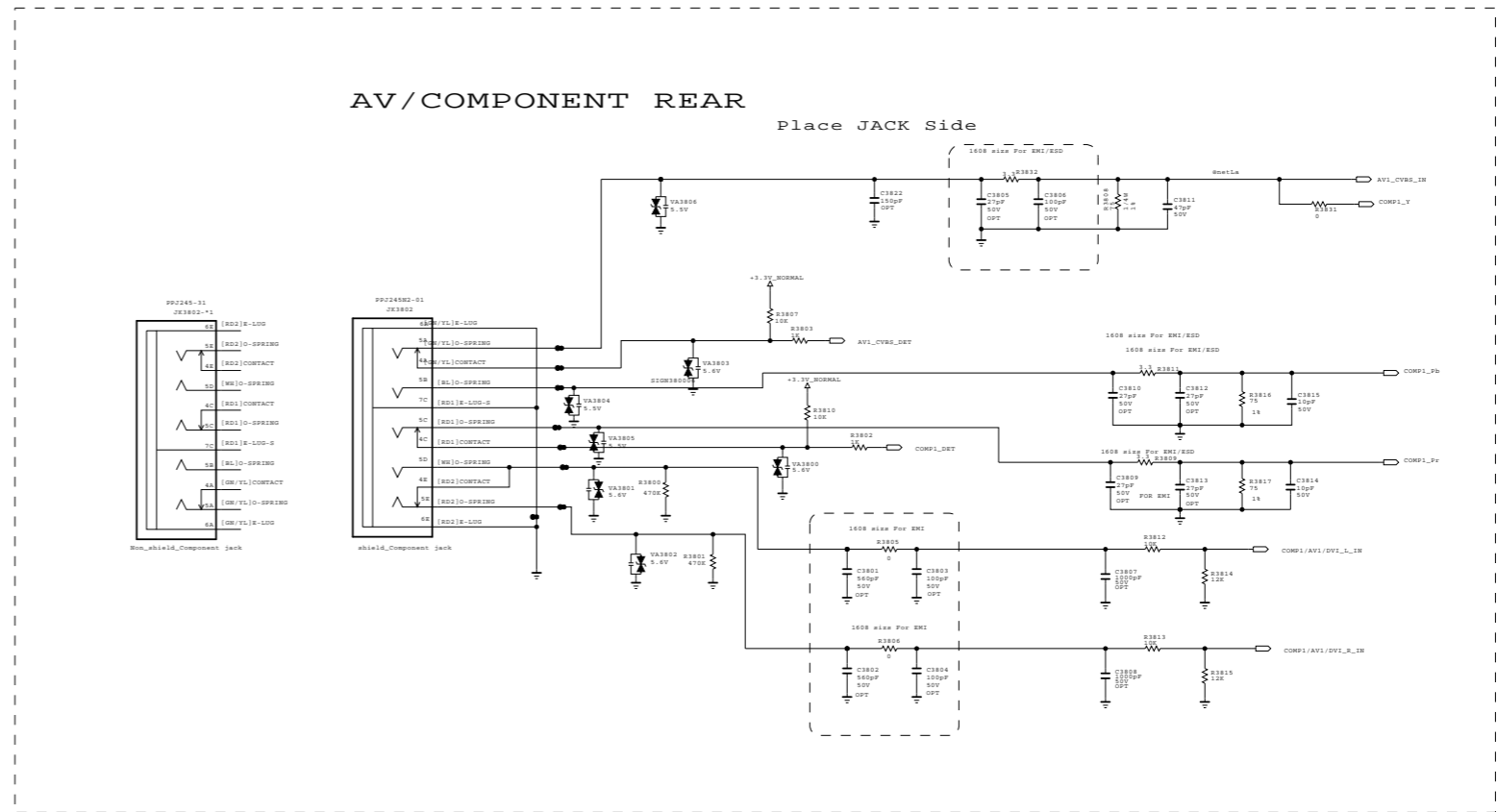
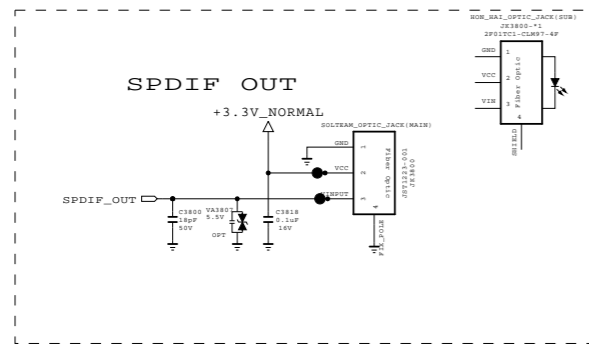

THE SYMBOL MARK OF THIS SCHEMATIC DIAGRAM INCORPORATES SPECIAL FEATURES IMPORTANT FOR PROTECTION FROM X-RADIATION. FIRE AND ELECTRICAL SHOCK HAZARDS, WHEN SERVICING IF IS ESSENTIAL THAT ONLY MANUFACTURERS SPECIFIED PARTS BE USED FOR THE CRITICAL COMPONENTS IN THE SYMBOL MARK OF THE SCHEMATIC.

SECRET
LGElectronics

LG ELECTRONICS

MODEL	LM15U	DATE	2015-01-23
BLOCK	JACK_COMMON_H_W/O HP	SHEET	38 /

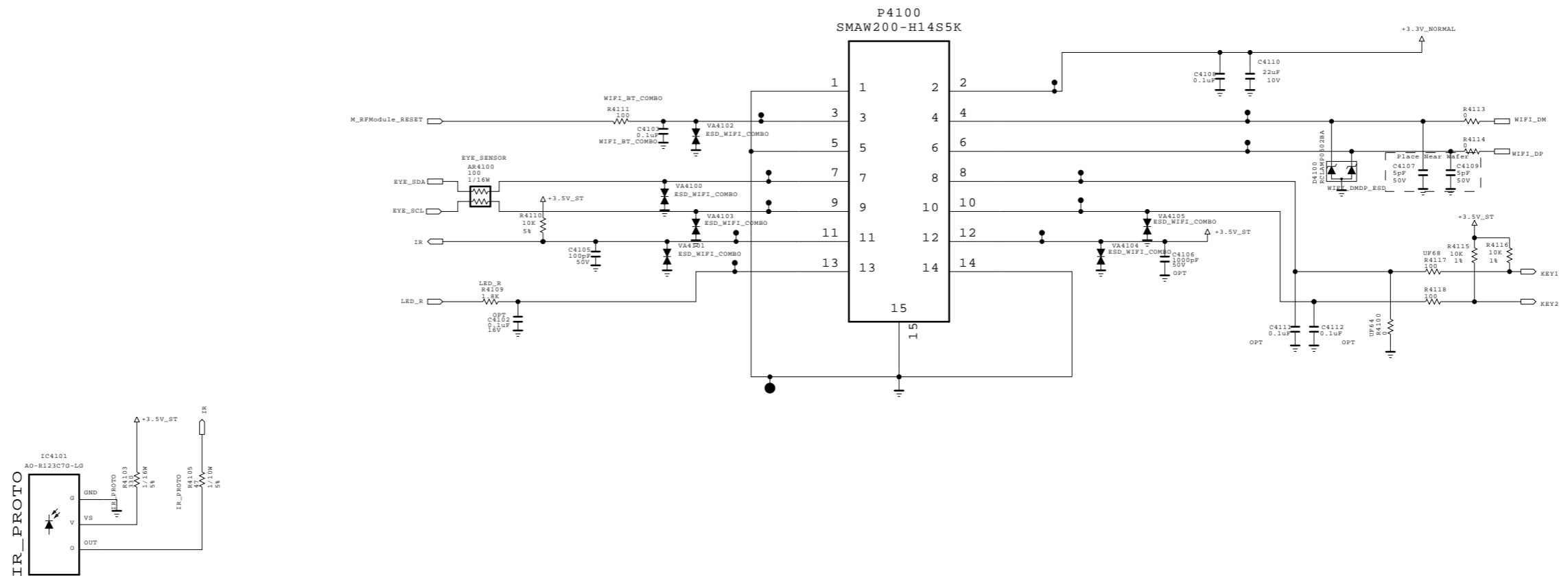



THE SYMBOL MARK OF THIS SCHEMATIC DIAGRAM INCORPORATES SPECIAL FEATURES IMPORTANT FOR PROTECTION FROM X-RADIATION. FIRE AND ELECTRICAL SHOCK HAZARDS, WHEN SERVICING IF IS ESSENTIAL THAT ONLY MANUFACTURES SPECIFIED PARTS BE USED FOR THE CRITICAL COMPONENTS IN THE SYMBOL MARK OF THE SCHEMATIC.

SECRET
LGElectronics

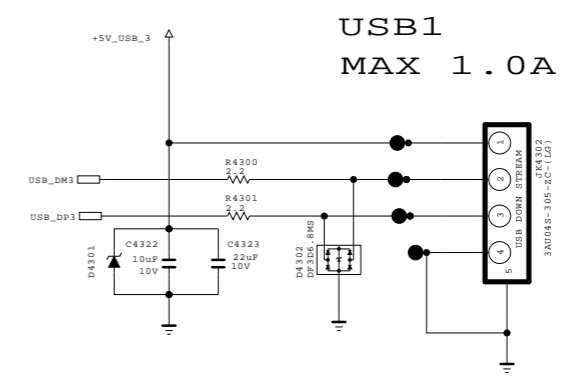

MODEL	UF64/6800	DATE	2015-01-21
BLOCK	IR/KEY	SHEET	41 /



THE  SYMBOL MARK OF THIS SCHEMATIC DIAGRAM INCORPORATES SPECIAL FEATURES IMPORTANT FOR PROTECTION FROM X-RADIATION. FIRE AND ELECTRICAL SHOCK HAZARDS, WHEN SERVICING IT IS ESSENTIAL THAT ONLY MANUFACTURERS SPECIFIED PARTS BE USED FOR THE CRITICAL COMPONENTS IN THE  SYMBOL MARK OF THE SCHEMATIC.

SECRET
LGElectronics



MODEL	UF64/6800	DATE	2015-01-21
BLOCK	USB	SHEET	43 /

Ethernet Block

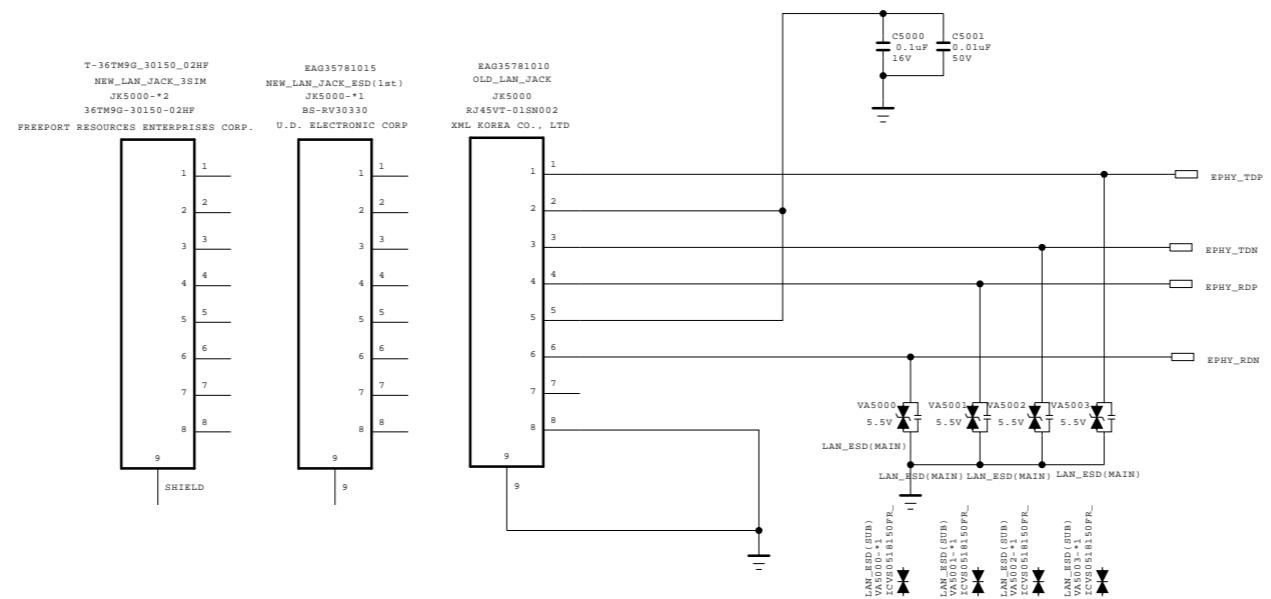

THE SYMBOL MARK OF THIS SCHEMATIC DIAGRAM INCORPORATES SPECIAL FEATURES IMPORTANT FOR PROTECTION FROM X-RADIATION. FIRE AND ELECTRICAL SHOCK HAZARDS, WHEN SERVICING IF IS ESSENTIAL THAT ONLY MANUFACTURES SPECIFIED PARTS BE USED FOR THE CRITICAL COMPONENTS IN THE SYMBOL MARK OF THE SCHEMATIC.

SECRET
LGElectronics



BSD-15Y-LM14A-050_00-HD

MODEL	LM14A	DATE	2015-01-21
BLOCK	LAN_H	SHEET	50 /

AUDIO AMP (NTP7515)

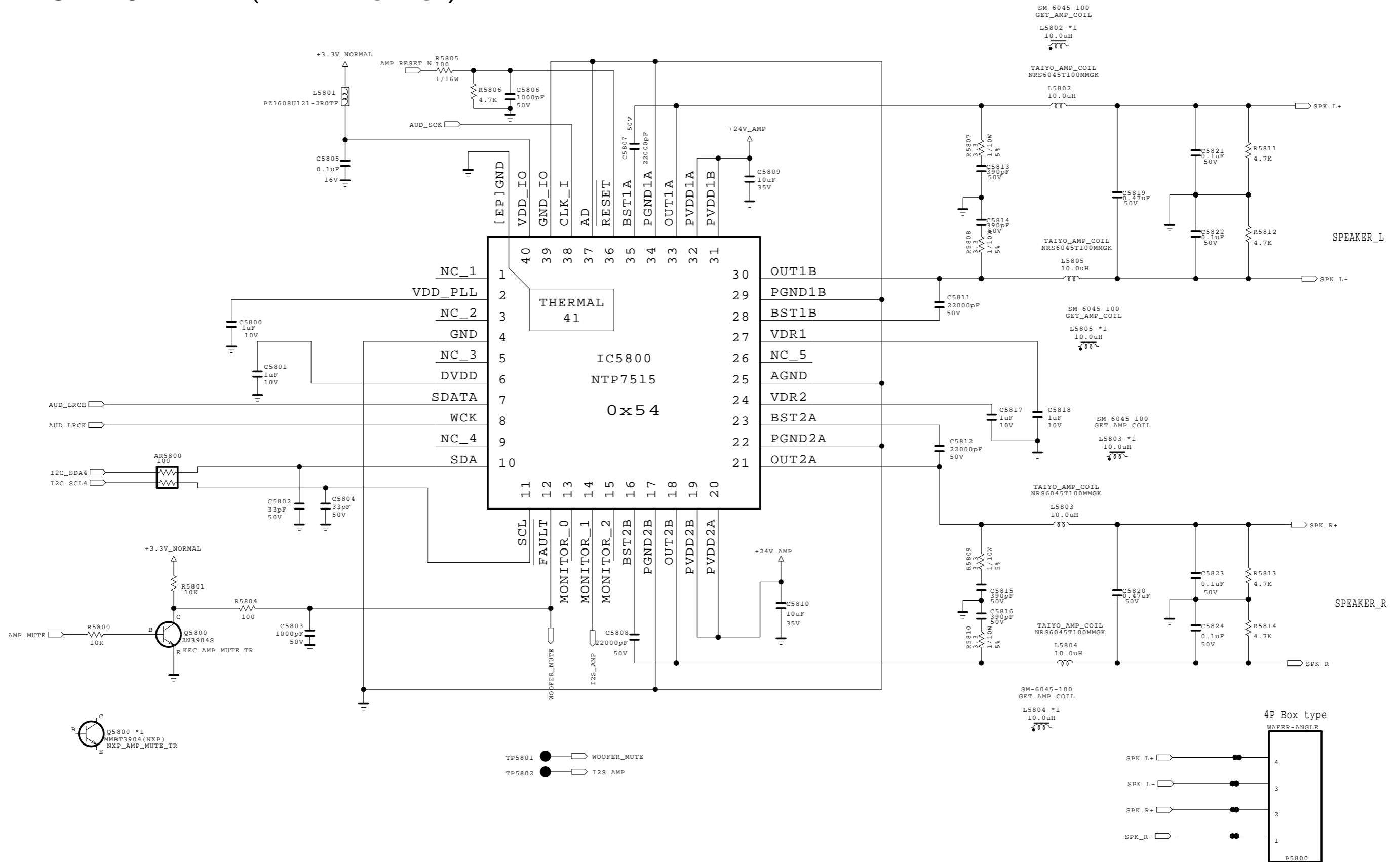

THE SYMBOL MARK OF THIS SCHEMATIC DIAGRAM INCORPORATES SPECIAL FEATURES IMPORTANT FOR PROTECTION FROM X-RADIATION. FIRE AND ELECTRICAL SHOCK HAZARDS, WHEN SERVICING IF IS ESSENTIAL THAT ONLY MANUFACTURES SPECIFIED PARTS BE USED FOR THE CRITICAL COMPONENTS IN THE SYMBOL MARK OF THE SCHEMATIC.

SECRET	LG ELECTRONICS
LGElectronics	

BSD-15Y-LM14A-058_00-HD			
MODEL	LM14A	DATE	2015-01-08
BLOCK	NTP_AMP	SHEET	58 /

1. should be guarded by ground
2. No via on both of them
3. Signal Width >= 12mils
Signal to Signal Width = 12mils
Ground Width >= 24mils

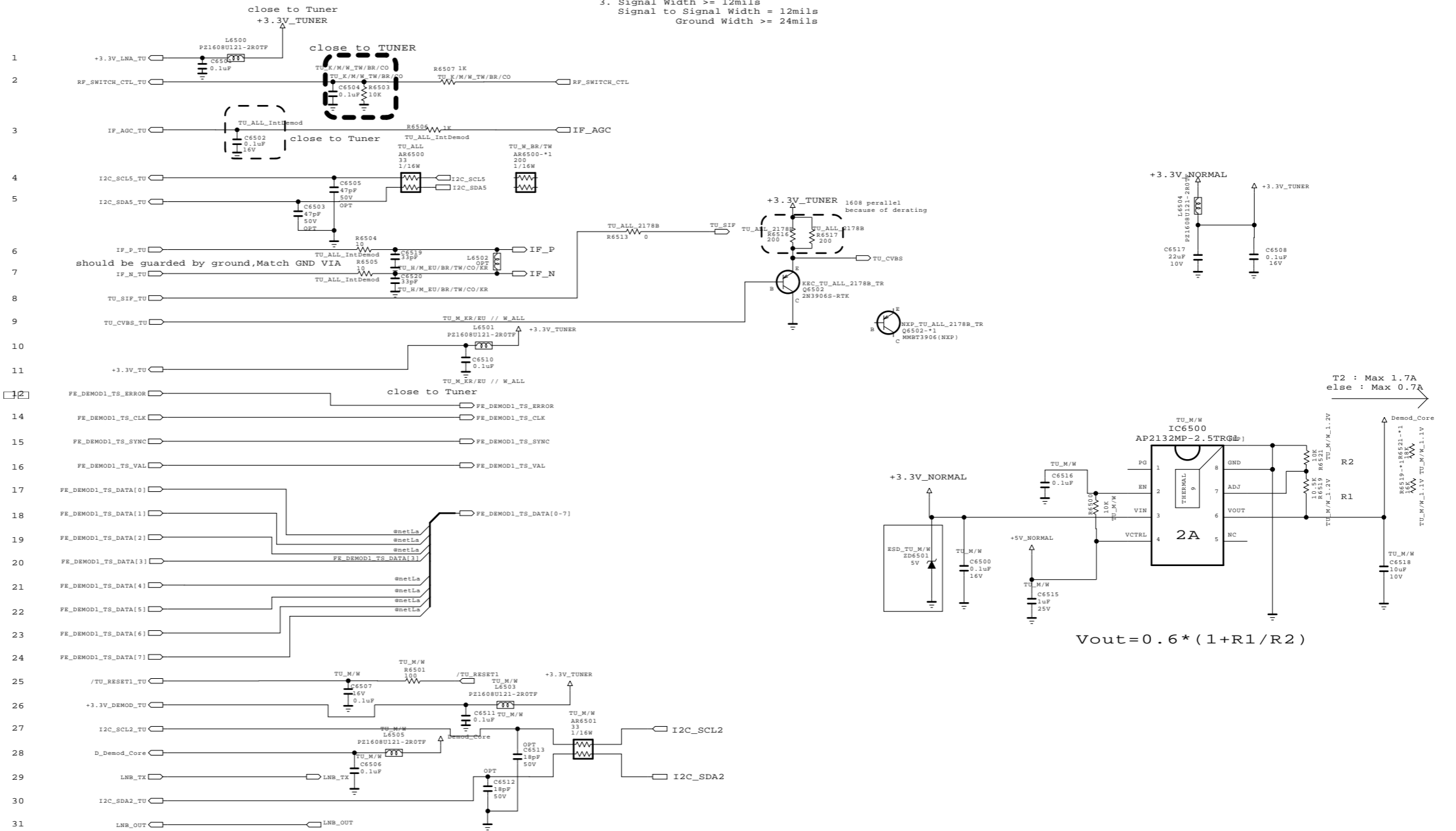

```

Global F/E Option Name
1. TU
2. Tuner Name = TDJ'H',TDJ'M'...
3. Country Name = KR,US,BR,EU ...

Example of Option name
TU_ALL_IntDemod = All Tuner type for Internal demod
TU_M/W = apply TDSM&TDSW Type Tuner

14' Tuner Type for Global
TDJ'H'-G101D : Half NIM for EU,AJJA
TDJ'H'-H101F : Half NIM for US, KR
TDJ'K'-T101F : Half NIM for TW
TDJ'M'-C301D,F : FULL NIM for China
TDJ'M'-B101F : Brazil NIM with Isolater Type
TDJ'M'-K101F : Colombia NIM
TDJ'M'-G101D,G105D,G151D : EU Combo&Full NIM
TDJ'M'-H101F,H151F : Korea PIP tuner
TDJ'W'-A151D : AJJA T2 PIP
  
```

$$V_{out} = 0.6 * (1 + R1/R2)$$

THE SYMBOL MARK OF THIS SCHEMATIC DIAGRAM INCORPORATES SPECIAL FEATURES IMPORTANT FOR PROTECTION FROM X-RADIATION. FIRE AND ELECTRICAL SHOCK HAZARDS, WHEN SERVICING IF IS ESSENTIAL THAT ONLY MANUFACTURES SPECIFIED PARTS BE USED FOR THE CRITICAL COMPONENTS IN THE SYMBOL MARK OF THE SCHEMATIC.

SECRET
LGElectronics



MODEL	UF64/6800	DATE	2014-11-06
BLOCK	TU_CIRCUIT	SHEET	65

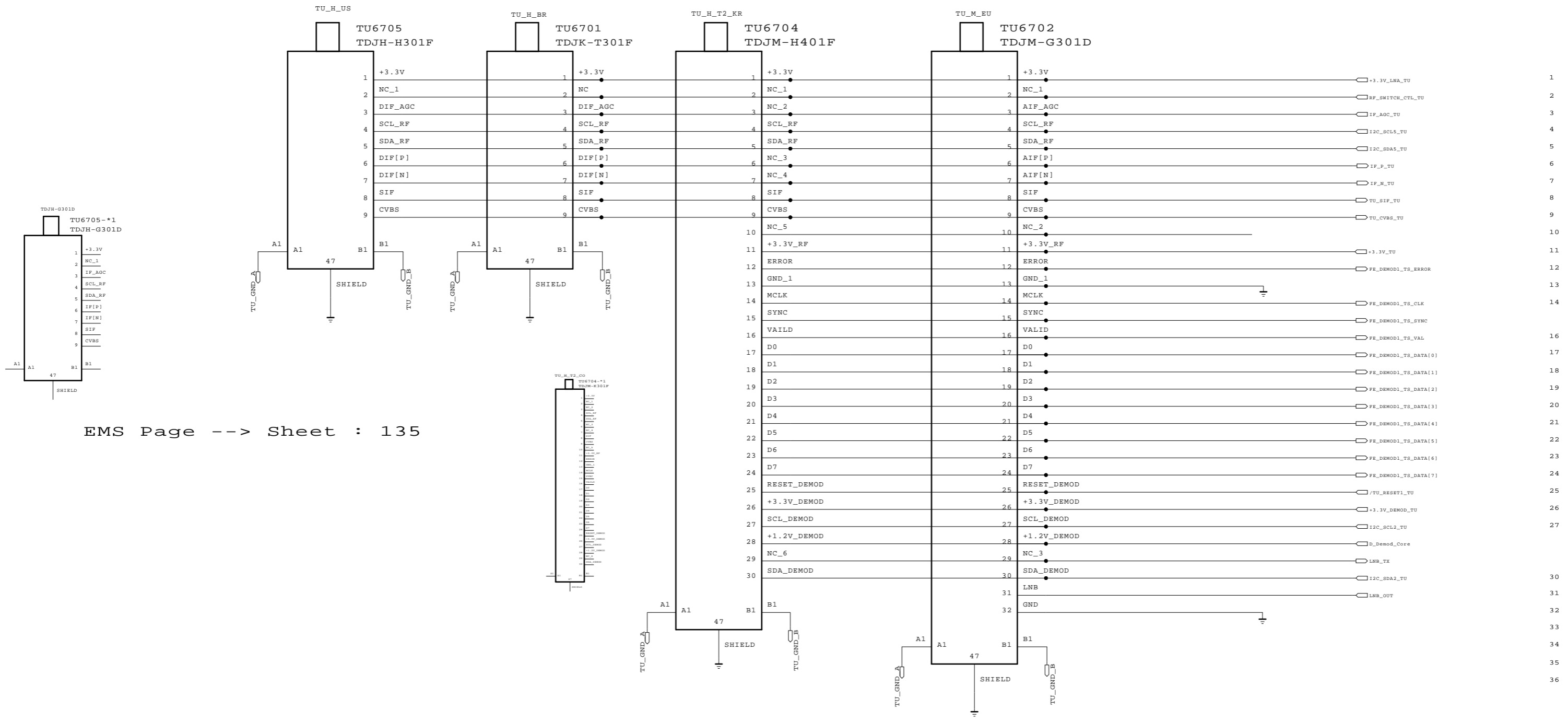

EMS Page --> Sheet : 135

THE SYMBOL MARK OF THIS SCHEMATIC DIAGRAM INCORPORATES SPECIAL FEATURES IMPORTANT FOR PROTECTION FROM X-RADIATION. FIRE AND ELECTRICAL SHOCK HAZARDS, WHEN SERVICING IF IS ESSENTIAL THAT ONLY MANUFACTURES SPECIFIED PARTS BE USED FOR THE CRITICAL COMPONENTS IN THE SYMBOL MARK OF THE SCHEMATIC.

SECRET
LGElectronics



MODEL	UF64/6800	DATE	2015-01-05
BLOCK	TU_SYMBOL_H	SHEET	67 /

eMMC I/F

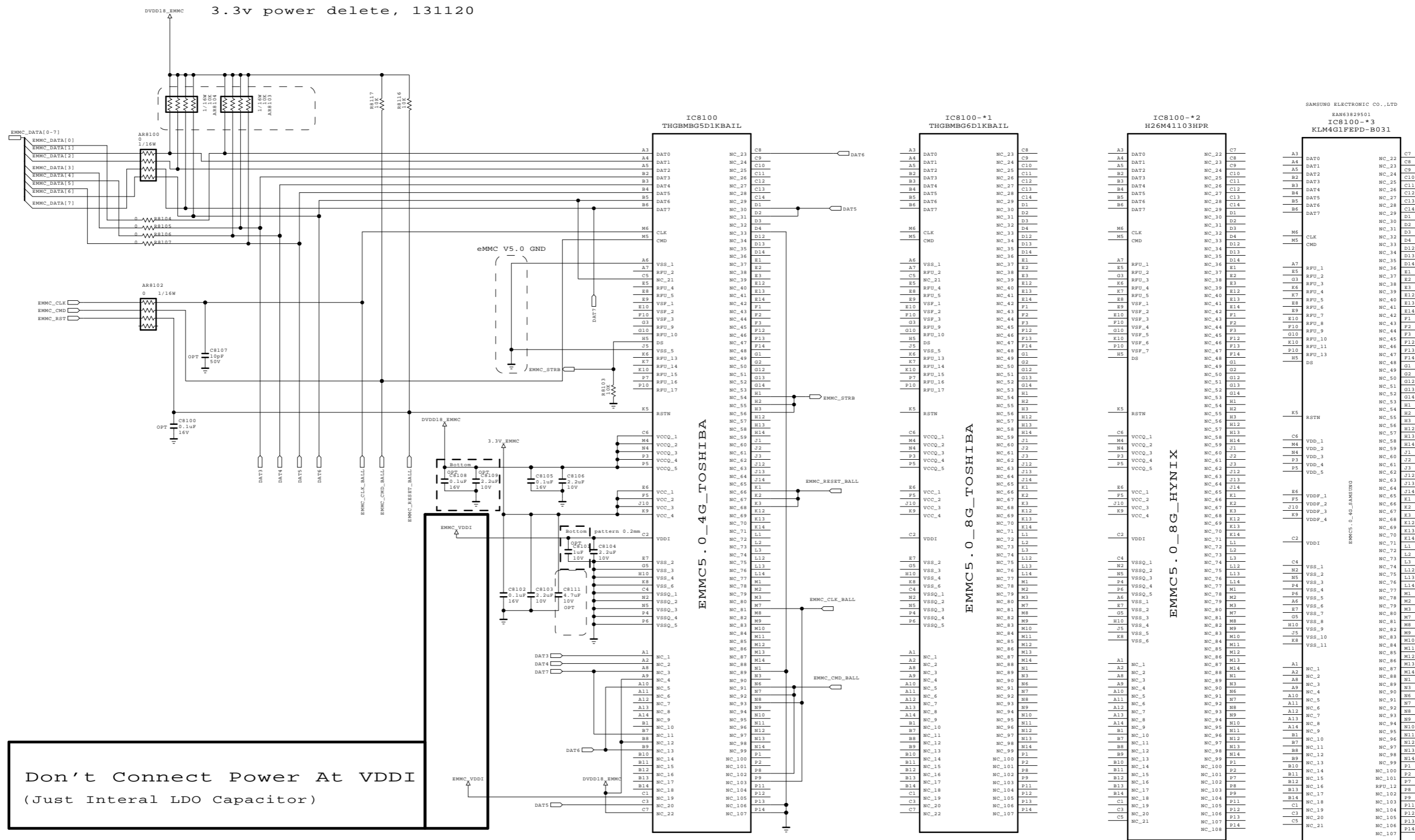

THE Δ SYMBOL MARK OF THIS SCHEMATIC DIAGRAM INCORPORATES SPECIAL FEATURES IMPORTANT FOR PROTECTION FROM X-RADIATION. FIRE AND ELECTRICAL SHOCK HAZARDS, WHEN SERVICING IF IS ESSENTIAL THAT ONLY MANUFACTURERS SPECIFIED PARTS BE USED FOR THE CRITICAL COMPONENTS IN THE Δ SYMBOL MARK OF THE SCHEMATIC.

SECRET
LGElectronics



BSD-15Y-LM14A-081_00-HD

MODEL	LM14A	DATE	
BLOCK	eMMC	SHEET	/

LM14A+URSA11(UF68/64)

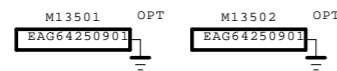

CLIP Top Side for Covershield

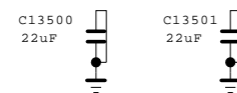

CLIP 1 - PUSH TYPE

Heatsink guide cap



THE  SYMBOL MARK OF THIS SCHEMATIC DIAGRAM INCORPORATES SPECIAL FEATURES IMPORTANT FOR PROTECTION FROM X-RADIATION. FIRE AND ELECTRICAL SHOCK HAZARDS, WHEN SERVICING IF IS ESSENTIAL THAT ONLY MANUFACTURES SPECIFIED PARTS BE USED FOR THE CRITICAL COMPONENTS IN THE  SYMBOL MARK OF THE SCHEMATIC.

SECRET
LGElectronics



MODEL	LM14A	DATE	2015-01-23
BLOCK	CLIP&Vx1_CAP	SHEET	135 /

LM14A UF64/68 TUNER EMS GND SEPERATION

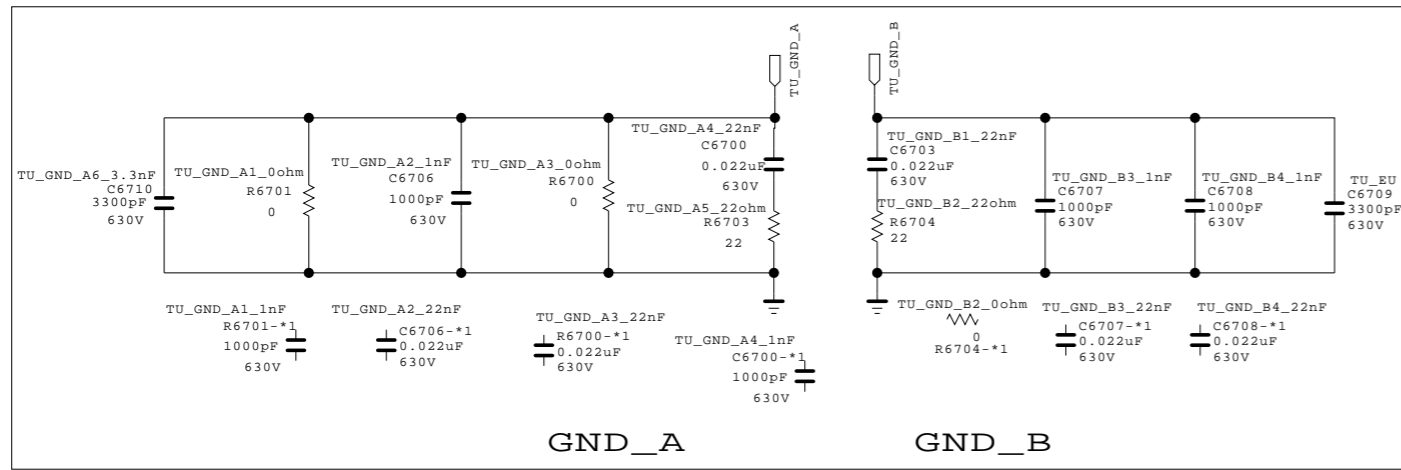

TU_GND_A	EU/CIS	AJJA	TW/COL	CN/HK	KR	North.AM	BR	JP
GND_A_1	0 ohm	0 ohm			X	0 ohm	X	0 ohm
GND_A_2	X	X			22 nF	X	22 nF	1 nF
GND_A_3	X	0 ohm			X	0 ohm	22 nF	0 ohm
GND_A_4	X	X			22 nF	X	22 nF	1 nF
GND_A_5	X	X			22 ohm	X	22 ohm	22 ohm

TU_GND_B	EU/CIS	AJJA	TW/COL	CN/HK	KR	North.AM	BR	JP
GND_B_1	X	X			22 nF	X	22 nF	X
GND_B_2	X	X			22 ohm	X	22 ohm	X
GND_B_3	1 nF	1 nF			22 nF	1 nF	22 nF	1 nF
GND_B_4	1 nF	1 nF			22 nF	1 nF	22 nF	1 nF

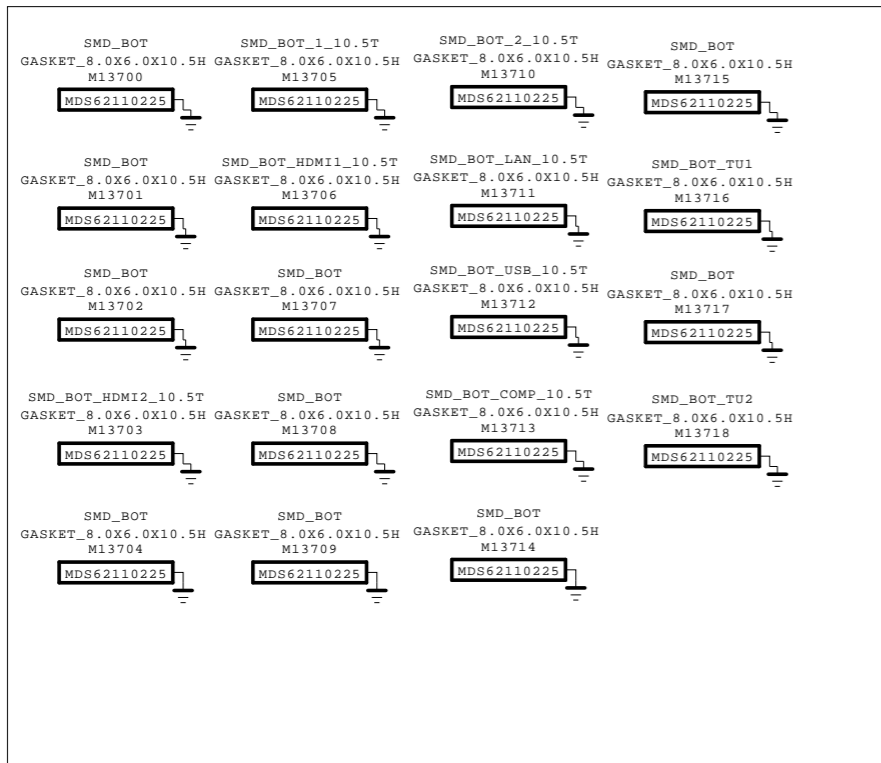

SMD_BOT_TU	EU/CIS	AJJA	TW/COL	CN/HK	KR	North.AM	BR	JP
TU1	○							
TU2	○							
TU3	X							

UF64/68 Error Pin TP - page 30.

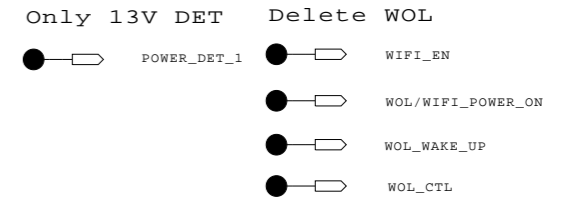

UF64/68 Error Pin TP - page 6.

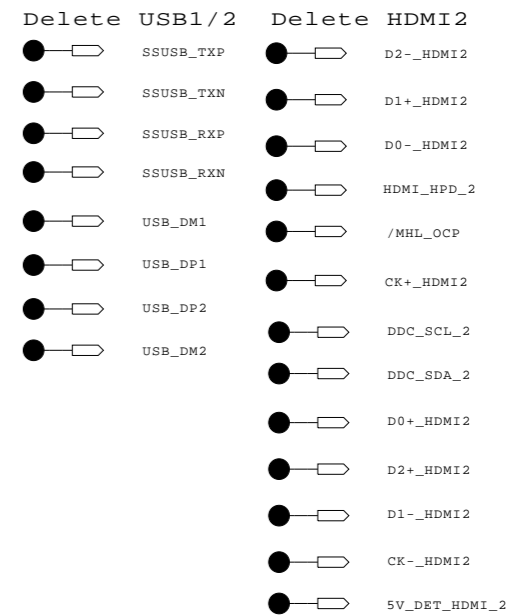

UF64/68 Error Pin TP - page 1.

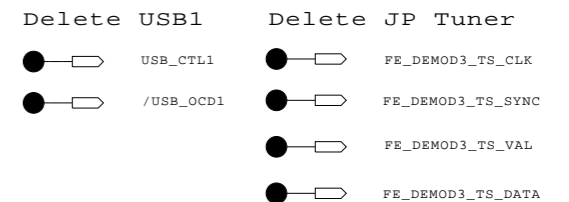

Delete EARPHONE AMP

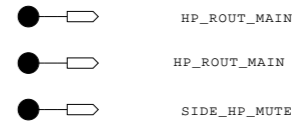

THE ⚠ SYMBOL MARK OF THIS SCHEMATIC DIAGRAM INCORPORATES SPECIAL FEATURES IMPORTANT FOR PROTECTION FROM X-RADIATION. FIRE AND ELECTRICAL SHOCK HAZARDS, WHEN SERVICING IF IS ESSENTIAL THAT ONLY MANUFACTURES SPECIFIED PARTS BE USED FOR THE CRITICAL COMPONENTS IN THE ⚠ SYMBOL MARK OF THE SCHEMATIC.

SECRET
LGElectronics

MODEL	LM14A (UF64/68)	DATE	2015-01-12
BLOCK	Tuner_GND_for UF64	SHEET	137 /

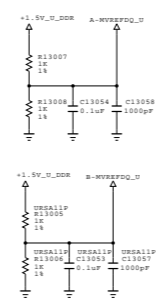
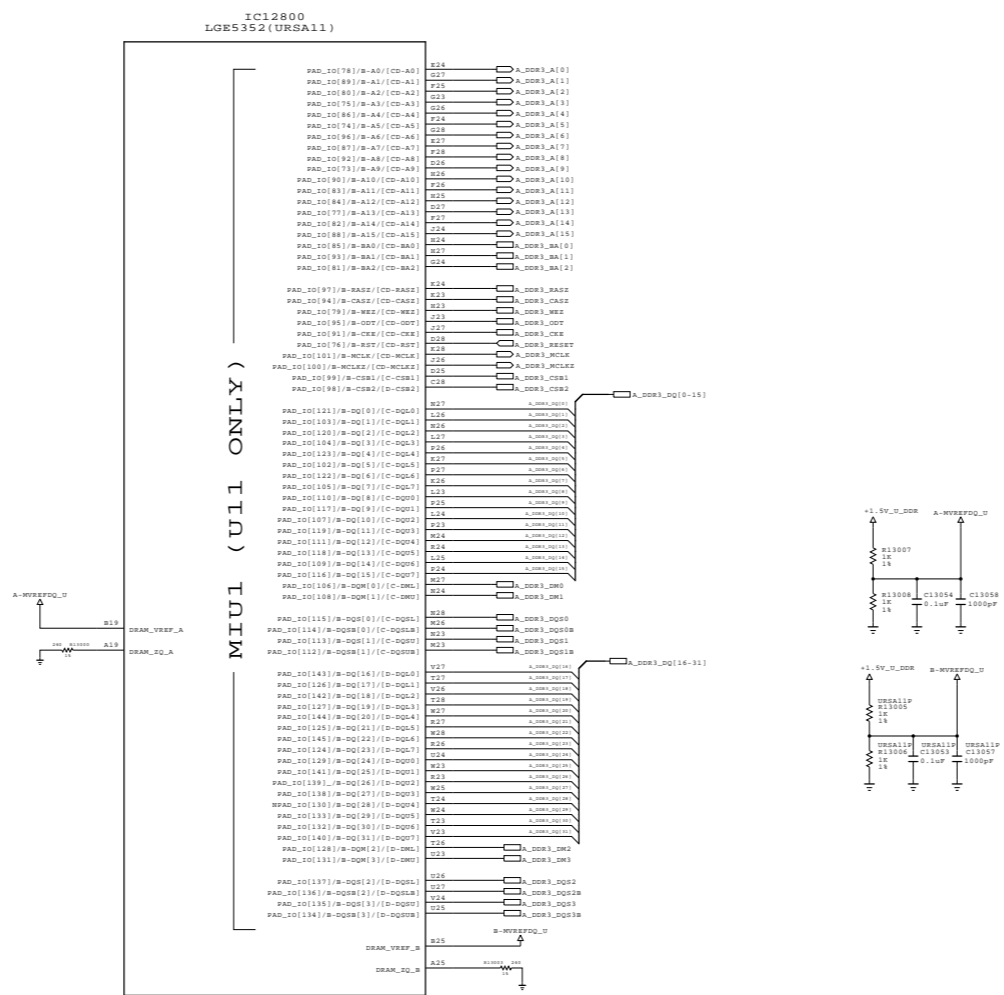

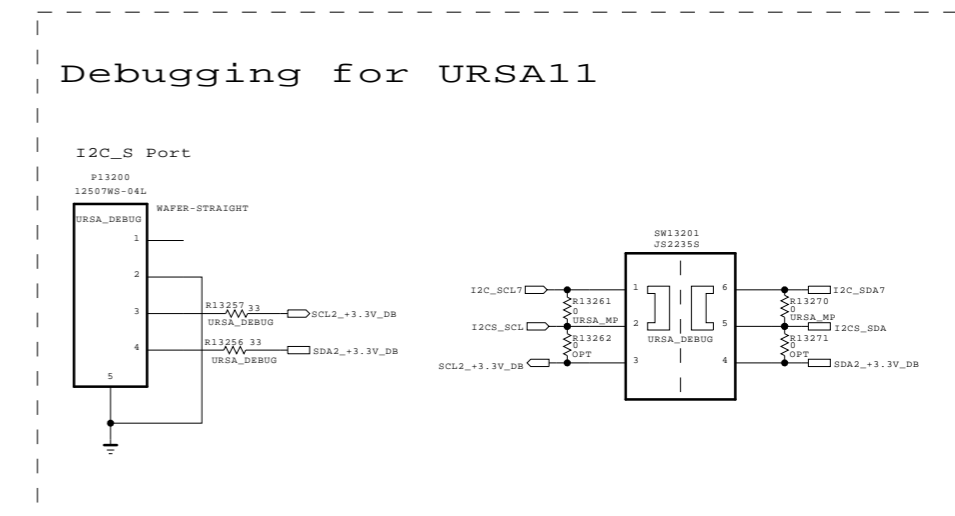
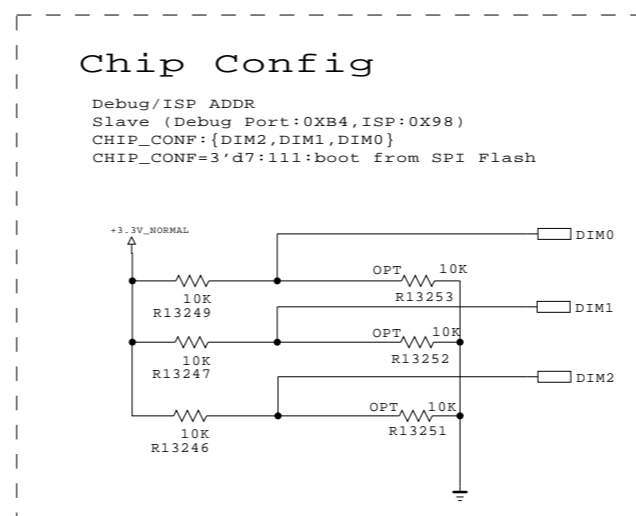
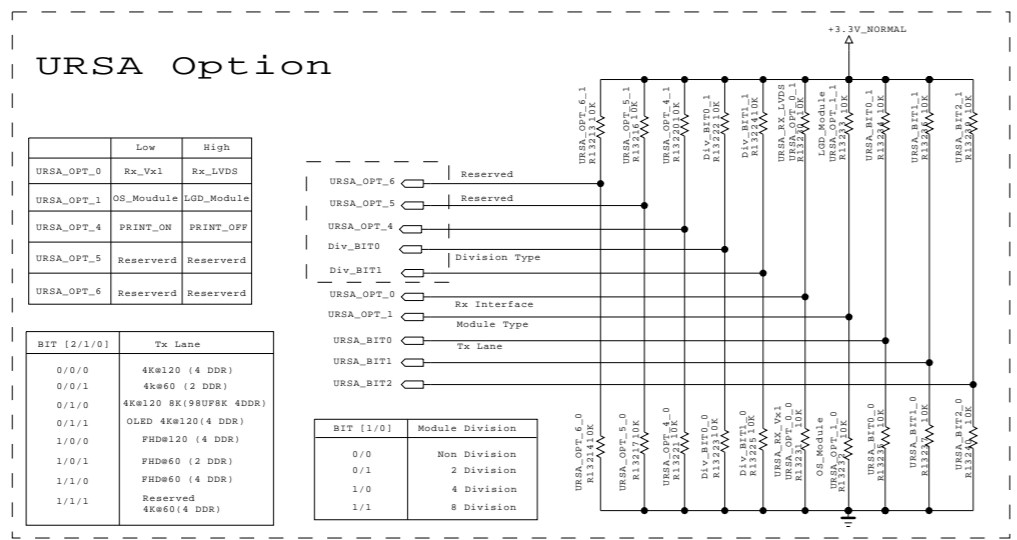
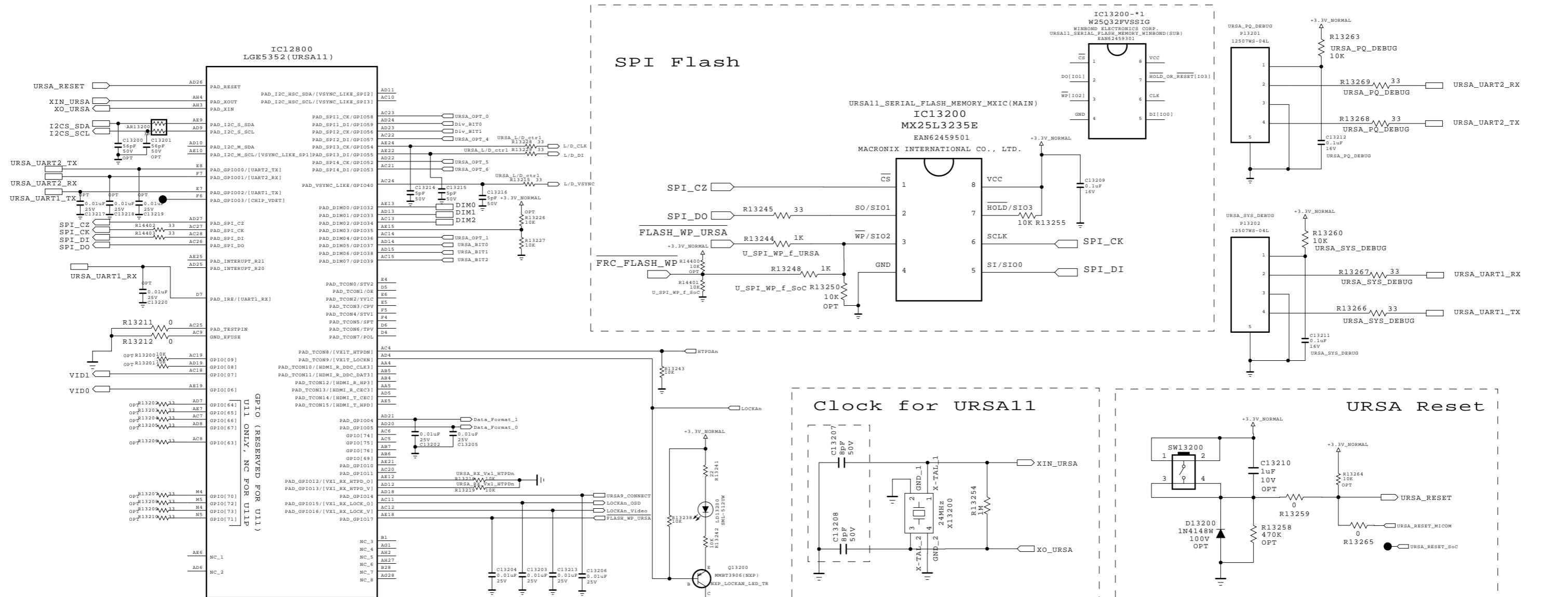

THE SYMBOL MARK OF THIS SCHEMATIC DIAGRAM INCORPORATES SPECIAL FEATURES IMPORTANT FOR PROTECTION FROM X-RADIATION. FIRE AND ELECTRICAL SHOCK HAZARDS, WHEN SERVICING IF IS ESSENTIAL THAT ONLY MANUFACTURERS SPECIFIED PARTS BE USED FOR THE CRITICAL COMPONENTS IN THE SYMBOL MARK OF THE SCHEMATIC.

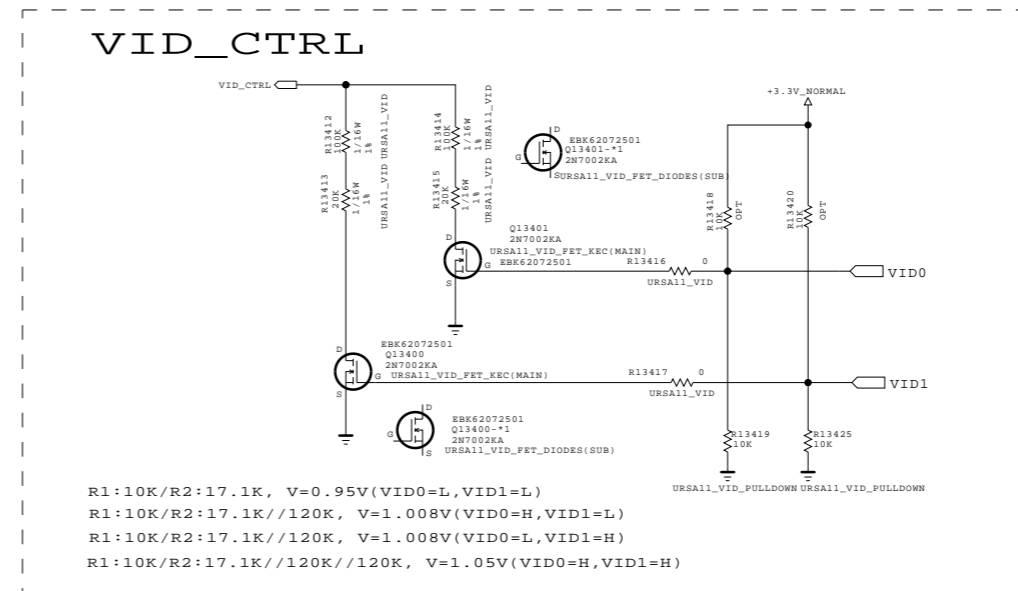
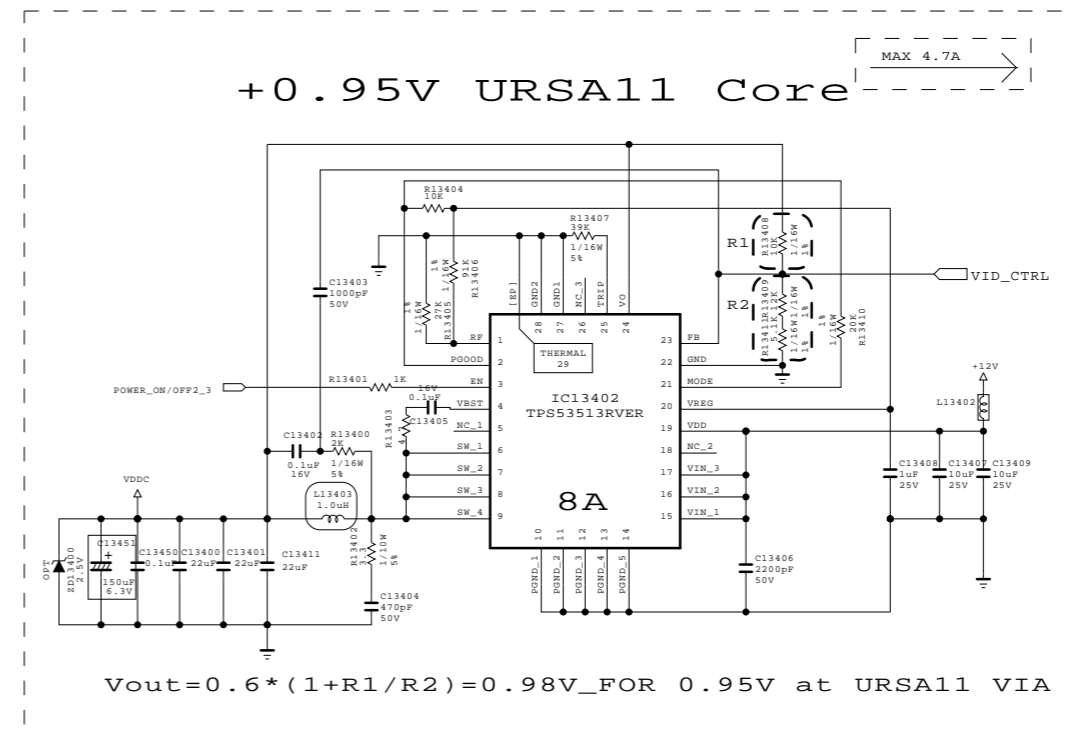
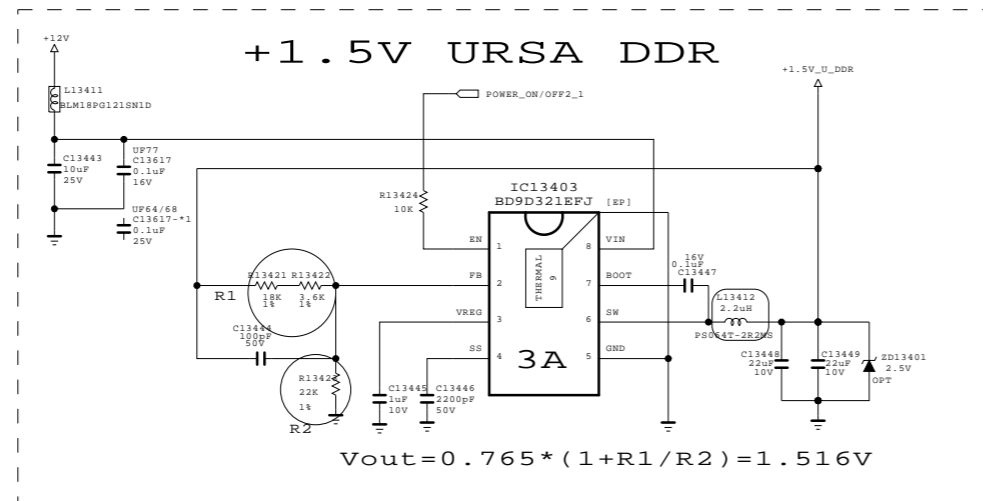

THE SYMBOL MARK OF THIS SCHEMATIC DIAGRAM INCORPORATES SPECIAL FEATURES IMPORTANT FOR PROTECTION FROM X-RADIATION. FIRE AND ELECTRICAL SHOCK HAZARDS, WHEN SERVICING IF IS ESSENTIAL THAT ONLY MANUFACTURES SPECIFIED PARTS BE USED FOR THE CRITICAL COMPONENTS IN THE SYMBOL MARK OF THE SCHEMATIC.

SECRET
LGElectronics



MODEL		DATE	
BLOCK	URSA11_DCDC	SHEET	/

BSD-15Y-LM14A-146_00-HD



TROUBLE SHOOTING GUIDE

Contents of Standard Repair Process

No.	Error symptom (High category)	Error symptom (Mid category)	Page	Remarks
1	A. Video error	No video/Normal audio	1	
2		No video/No audio	2	
3		Picture broken/ Freezing	3	
4		Color error	4	
5		Vertical/Horizontal bar, residual image, light spot, external device color error	5	
6	B. Power error	No power	6	
7		Off when on, off while viewing, power auto on/off	7	
8	C. Audio error	No audio/Normal video	8	
9		Wrecked audio/discontinuation/noise	9	
10	D. Function error	Remote control & Local switch checking	10	
11		MR15 operating checking	11	
12		Wifi operating checking	12	
13		Camera operating checking	13	
14		External device recognition error	14	
15	E. Noise	Circuit noise, mechanical noise	15	
16	F. Exterior error	Exterior defect	16	

First of all, Check whether there is SVC Bulletin in GCSC System for these model.

	Error symptom	A. Video error	Established date	
		No video/ Normal audio	Revised date	1/16

**First of all, Check whether all of cables between board is inserted properly or not.
(Main B/D↔ Power B/D, LVDS Cable, Speaker Cable, IR B/D Cable,,)**

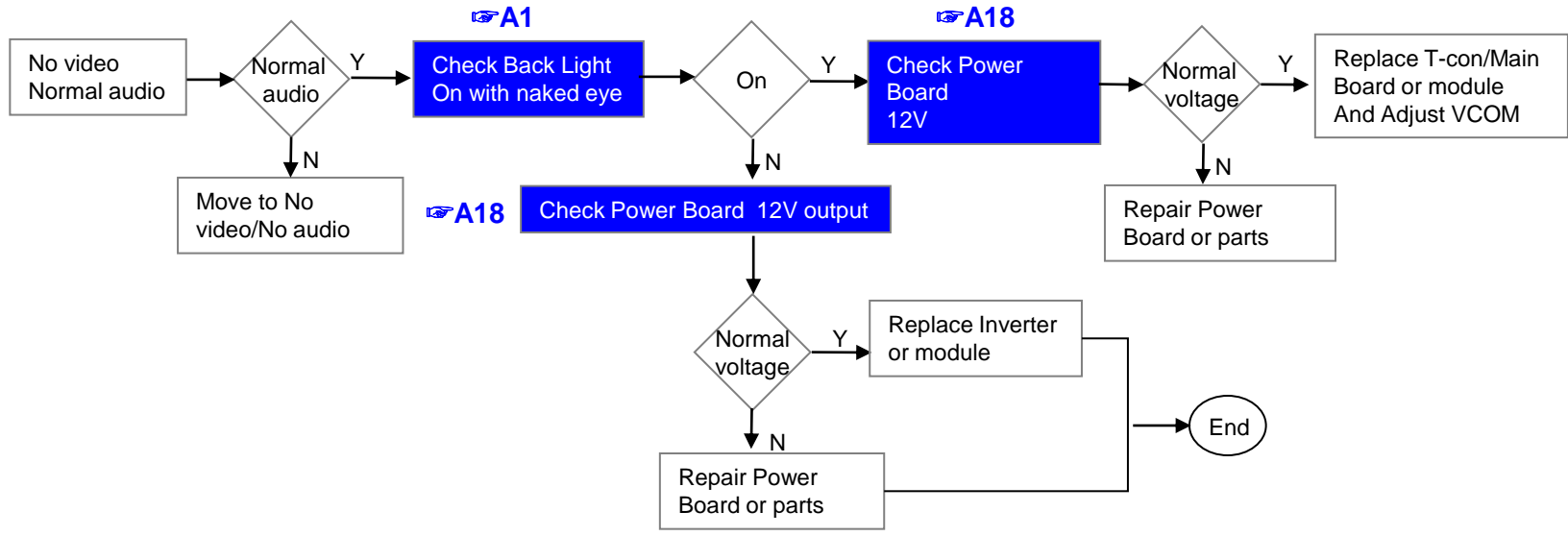

※ Precaution A4 & A2

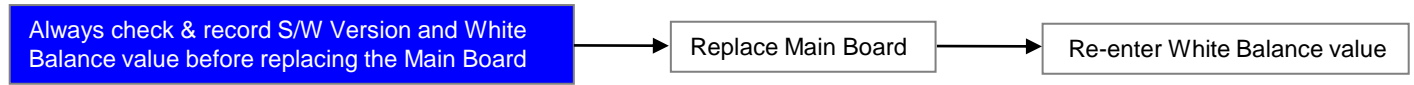

	Error symptom	A. Video error	Established date	
		No video/ No audio	Revised date	2/16

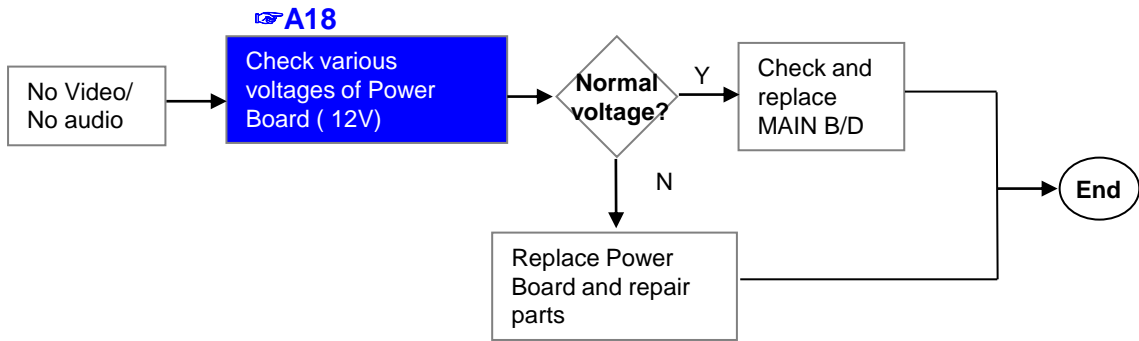

Error symptom	A. Video error	Established date	
	Picture broken/ Freezing	Revised date	3/16

A3

Check RF Signal level

- . By using Digital signal level meter
- . By using Diagnostics menu on OSD
(Advanced → Channels → Channel Tuning → Manual Tuning → Check the Signal)
- Signal strength (Normal : over 50%)
- Signal Quality (Normal: over 50%)

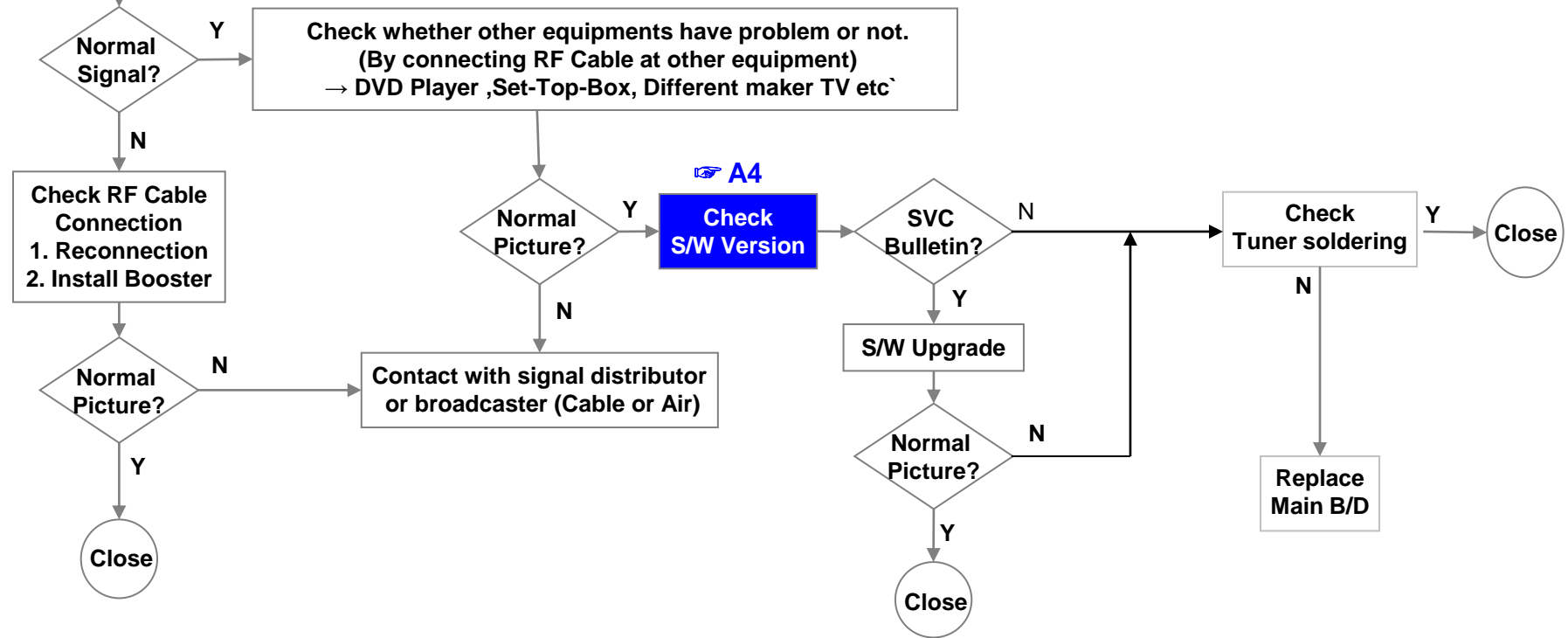

Error symptom	A. Video error		Established date	
	Color error		Revised date	4/16

A6

Check color by input
-External Input
-COMPONENT
-AV
-HDMI

A7

※ Check and replace Link Cable (V by one) and contact condition

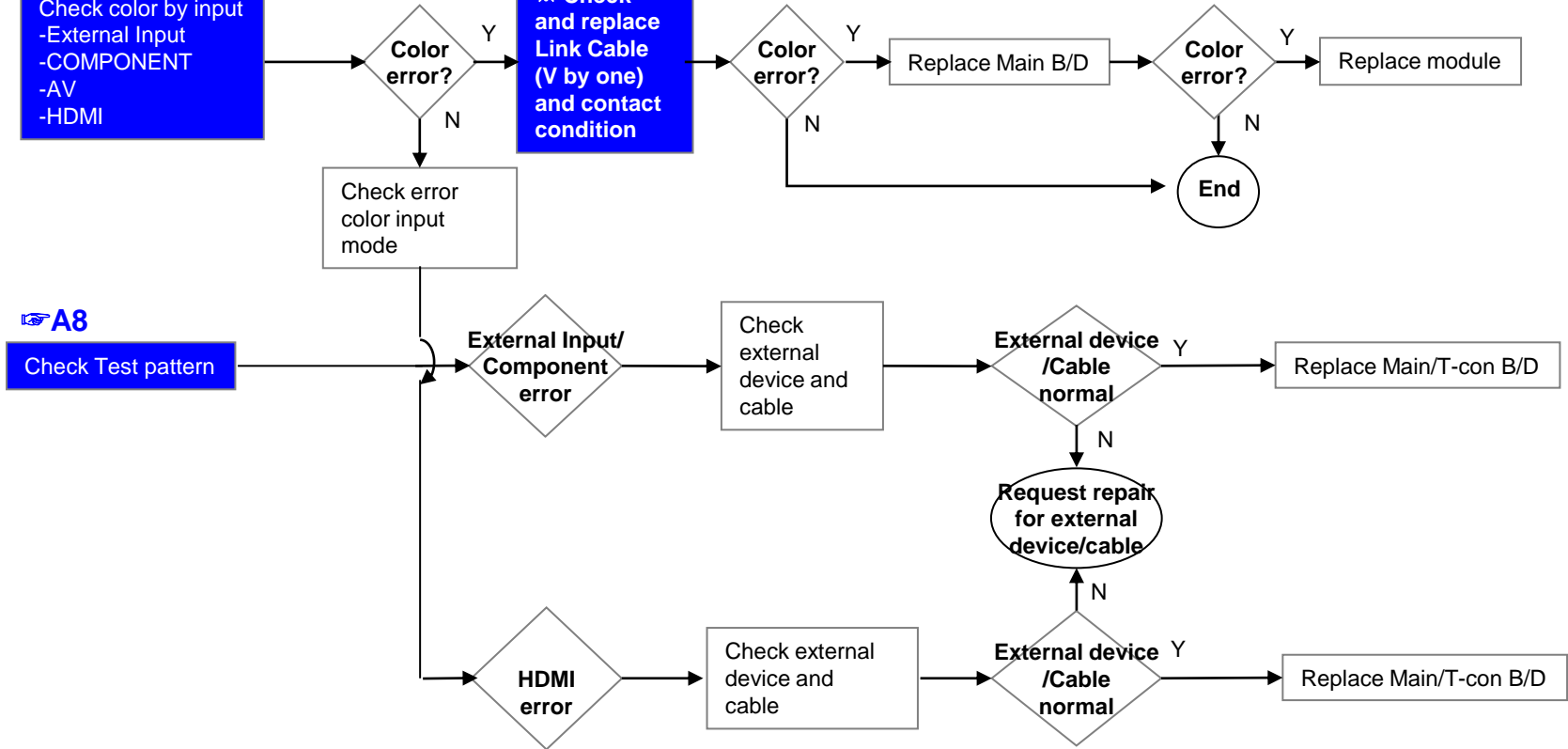

Error symptom	A. Video error		Established date	
	Vertical / Horizontal bar, residual image, light spot, external device color error		Revised date	5/16

Vertical/Horizontal bar, residual image, light spot

A6

Check color condition by input
-External Input
-Component
-HDMI

A8

Check Test pattern

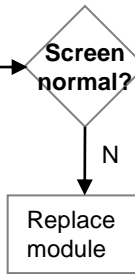

Check external device connection condition

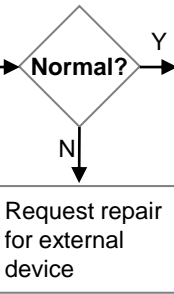

A7

Check and replace Link Cable

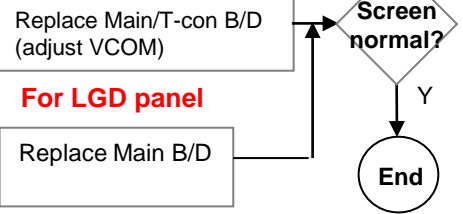
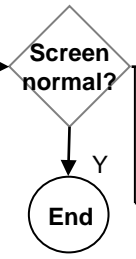

External device screen error-Color error

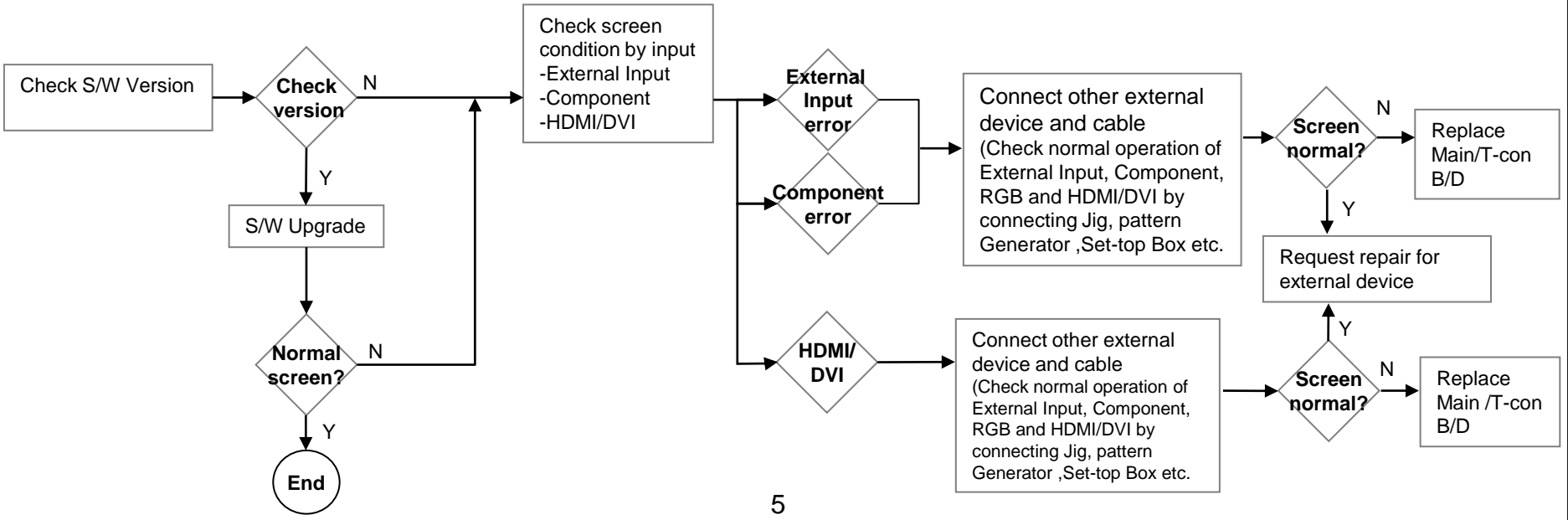

Error symptom	B. Power error		Established date	
	No power		Revised date	6/16

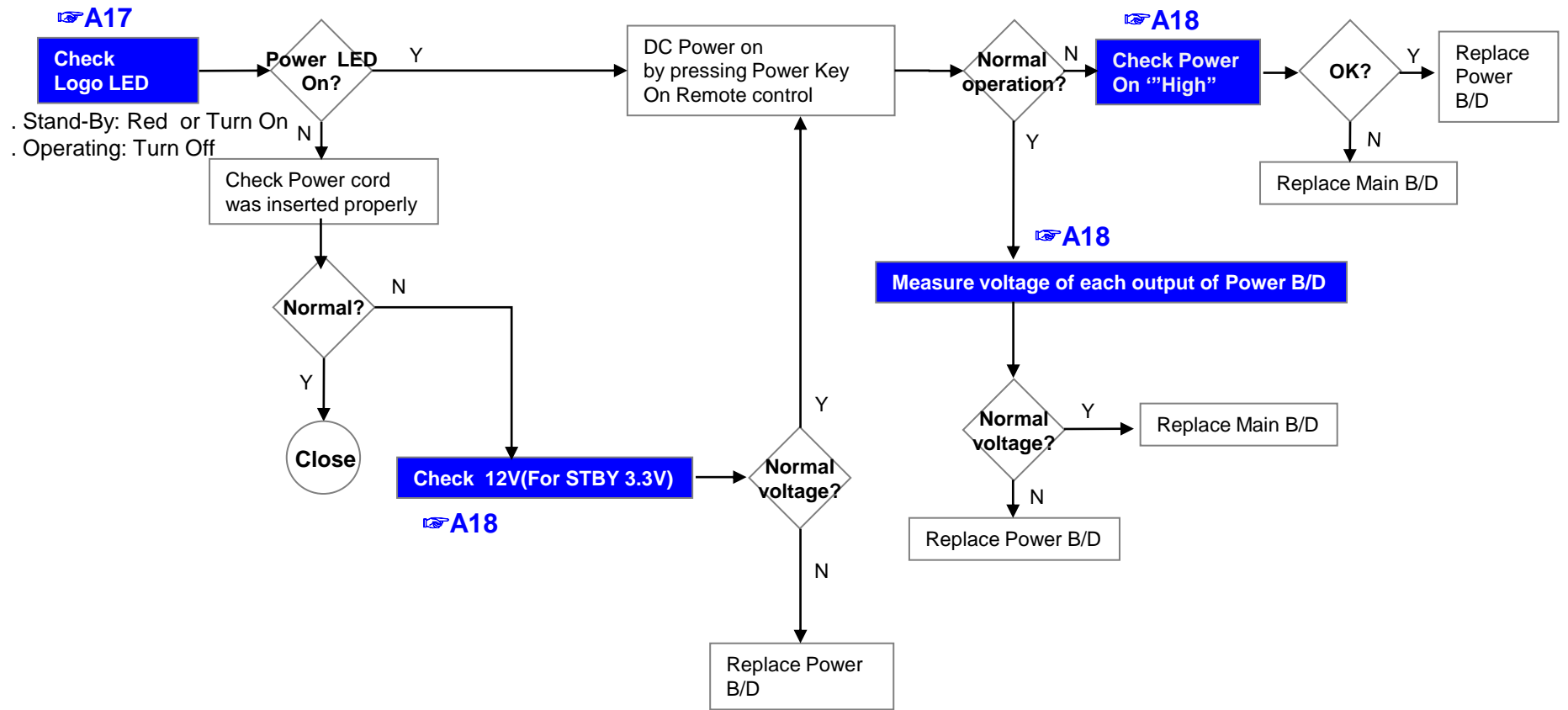

Error symptom	B. Power error		Established date	
	Off when on, off while viewing, power auto on/off		Revised date	7/16

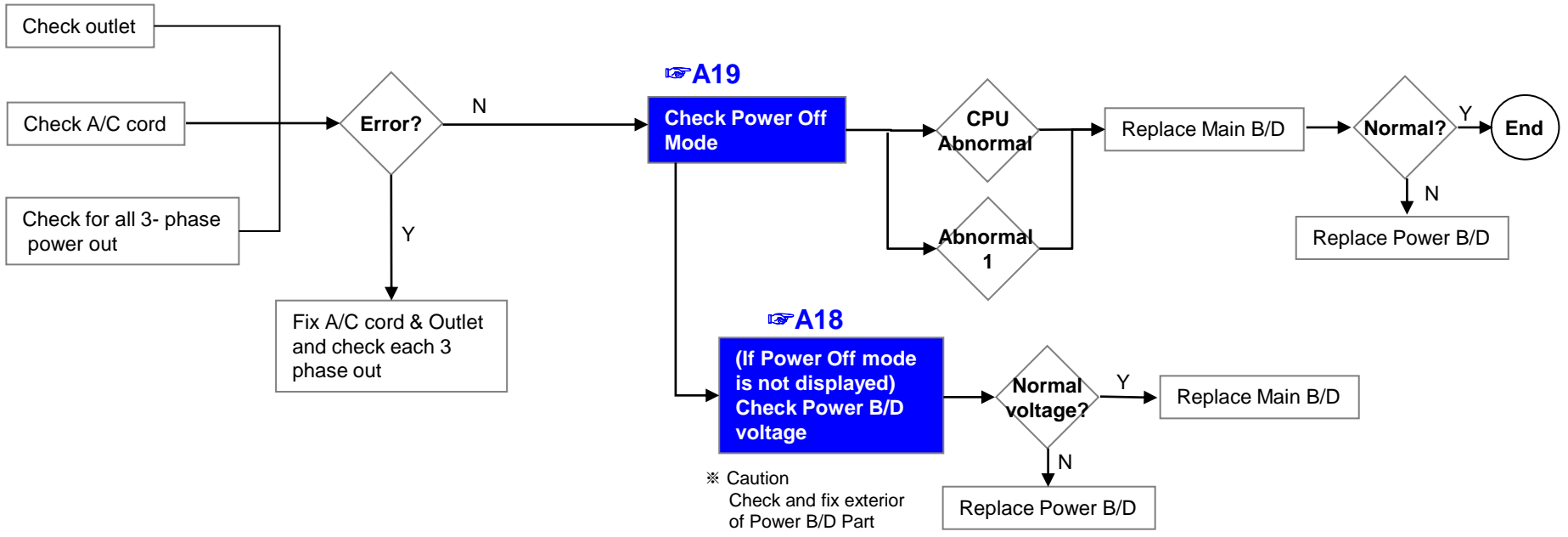

* Please refer to the all cases which can be displayed on power off mode.

Status	Power off List	Explanation
Normal	"POWEROFF_REMOTEKEY"	Power off by REMOTE CONTROL
	"POWEROFF_OFFTIMER"	Power off by OFF TIMER
	"POWEROFF_SLEEPTIMER"	Power off by SLEEP TIMER
	"POWEROFF_INSTOP"	Power off by INSTOP KEY
	"POWEROFF_AUTOOFF"	Power off by AUTO OFF
	"POWEROFF_ONTIMER"	Power off by ON TIMER
	"POWEROFF_RS232C"	Power off by RS232C
	"POWEROFF_RESREC"	Power off by Reserved Record
	"POWEROFF_RECEND"	Power off by End of Recording
	"POWEROFF_SWDOWN"	Power off by S/W Download
Abnormal	"POWEROFF_UNKNOWN"	Power off by unknown status except listed case
	"POWEROFF_ABNORMAL1" "POWEROFF_CPUABNORMAL"	Power off by abnormal status except CPU trouble Power off by CPU Abnormal

Error symptom	C. Audio error	Established date	
	No audio/ Normal video	Revised date	8/16

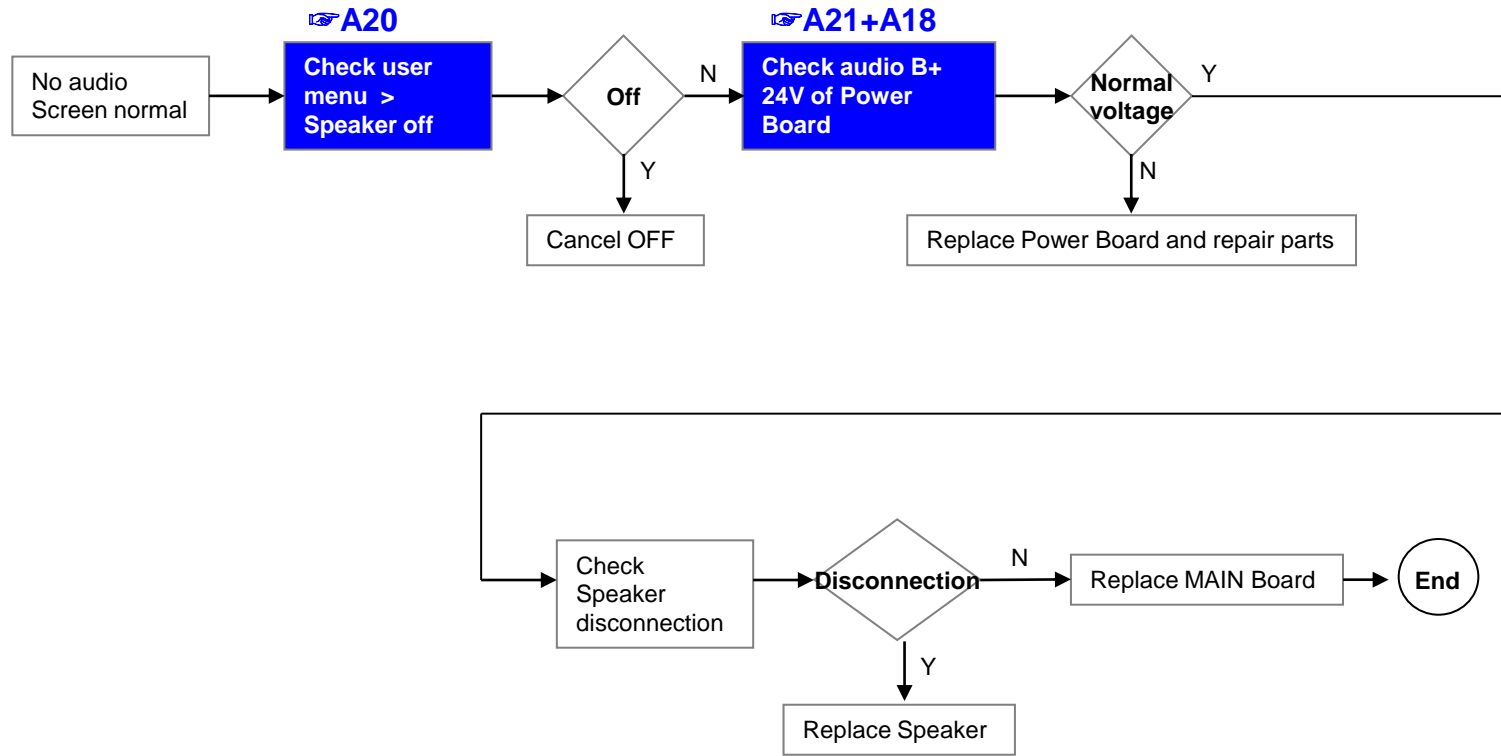

Error symptom	C. Audio error		Established date	
	Wrecked audio/ discontinuation/noise		Revised date	9/16

→ abnormal audio/discontinuation/noise is same after “Check input signal” compared to No audio

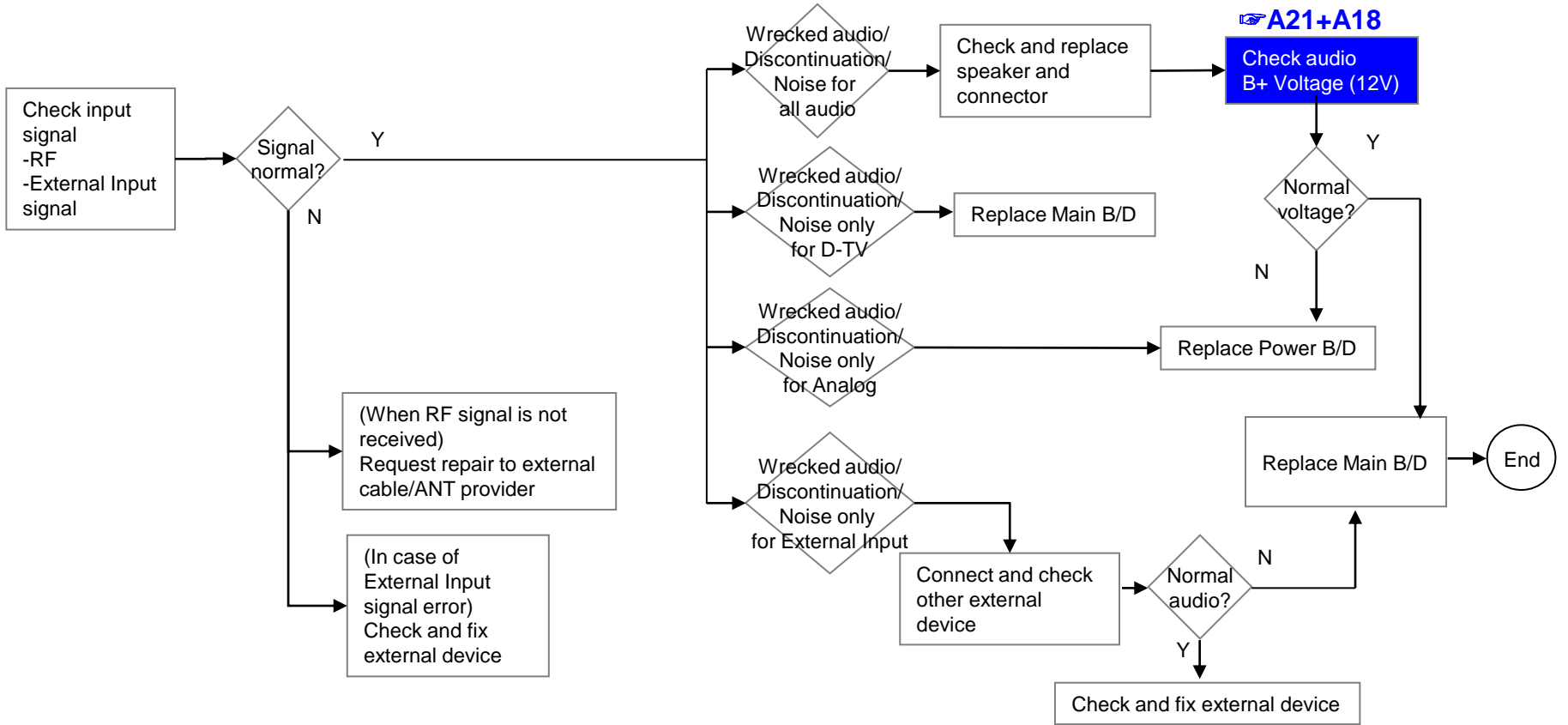

	Error symptom	D. Function error	Established date		
		Remote control & Local switch checking	Revised date		10/16

1. Remote control(R/C) operating error

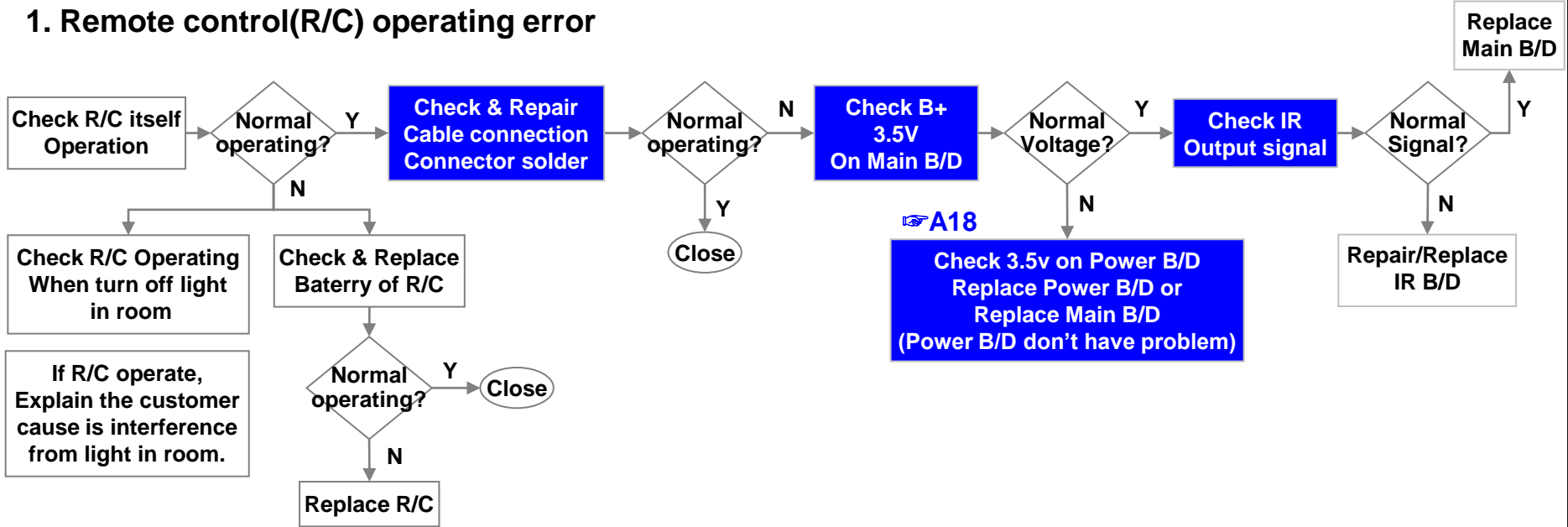

	Error symptom	D. Function error	Established date	
		MR13 operating checking	Revised date	11/16

2. MR15(Magic Remocon) operating error

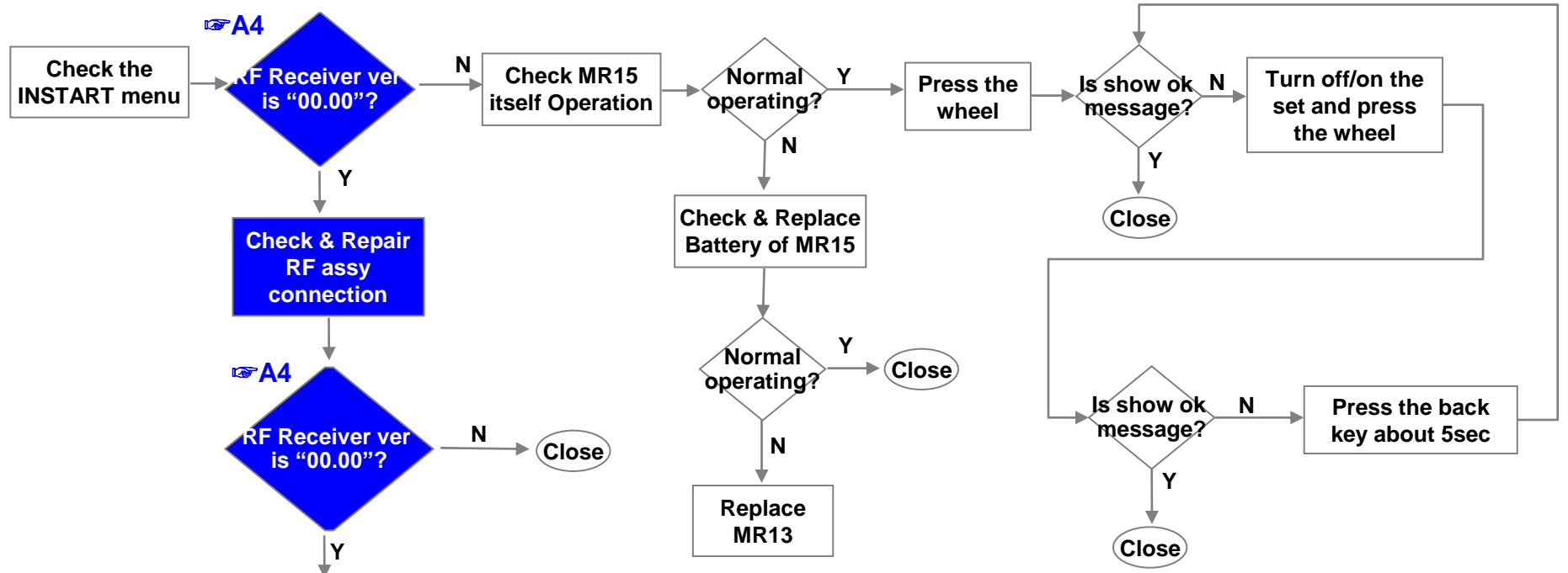

Down load the Firmware
 * INSTART MENU→14.RF Remocon Test→3. Firmware download

* If you conduct the loop at 3times, change the M4.

Error symptom	D. Function error	Established date	
	Wifi operating checking	Revised date	12/16

3.Wifi operating error

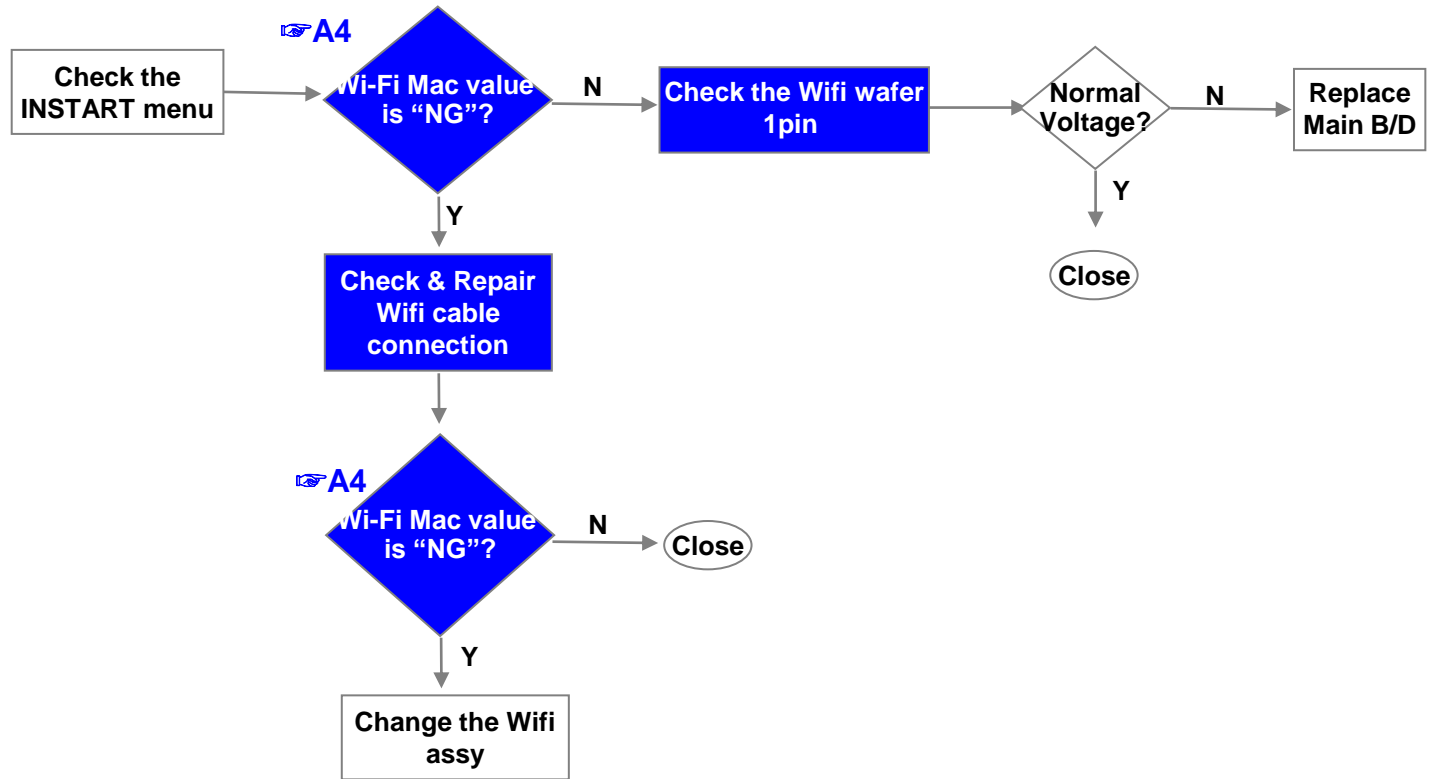

Error symptom	D. Function error	Established date	
	Camera operating checking	Revised date	13/16

4.Camera operating error

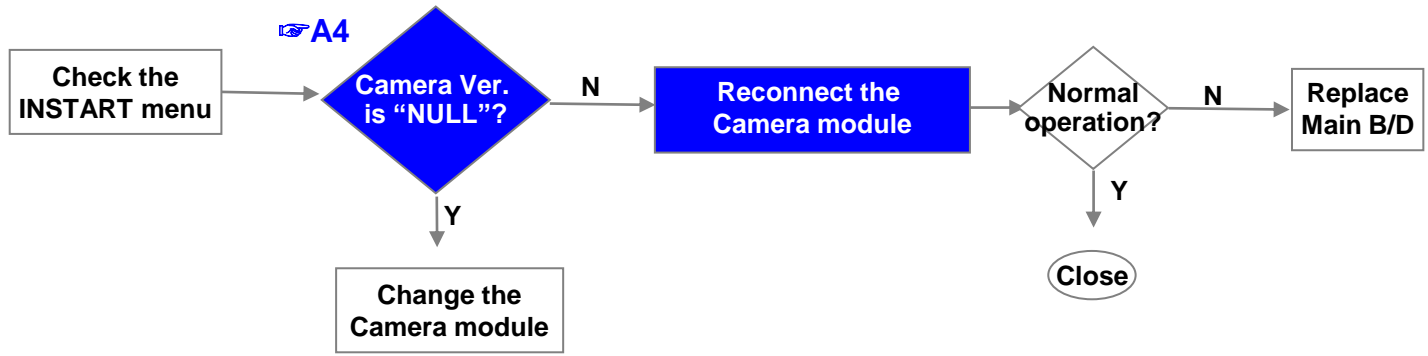

	Error symptom	D. Function error	Established date	
		External device recognition error	Revised date	14/16

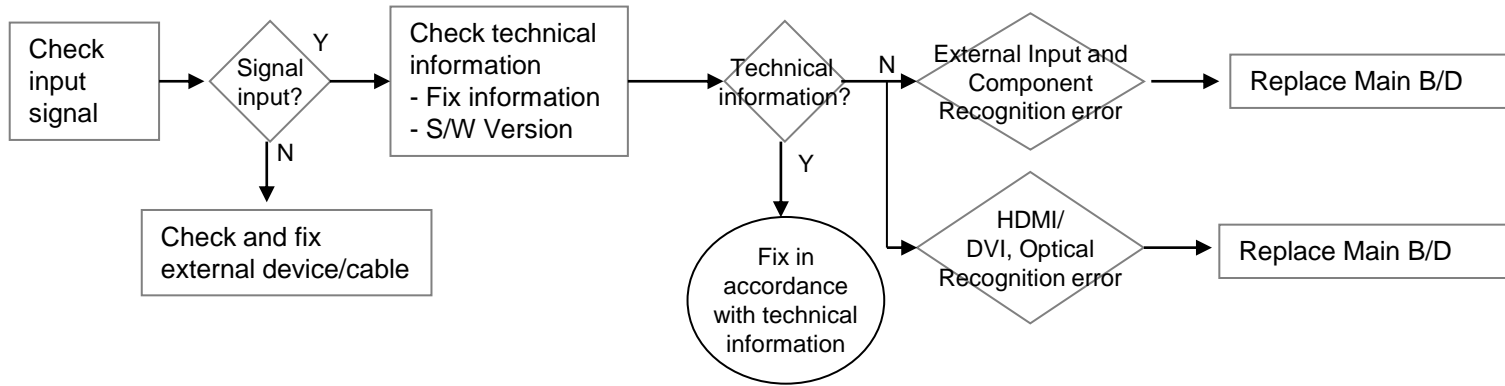

Error symptom	E. Noise	Established date		
	Circuit noise, mechanical noise	Revised date		15/16

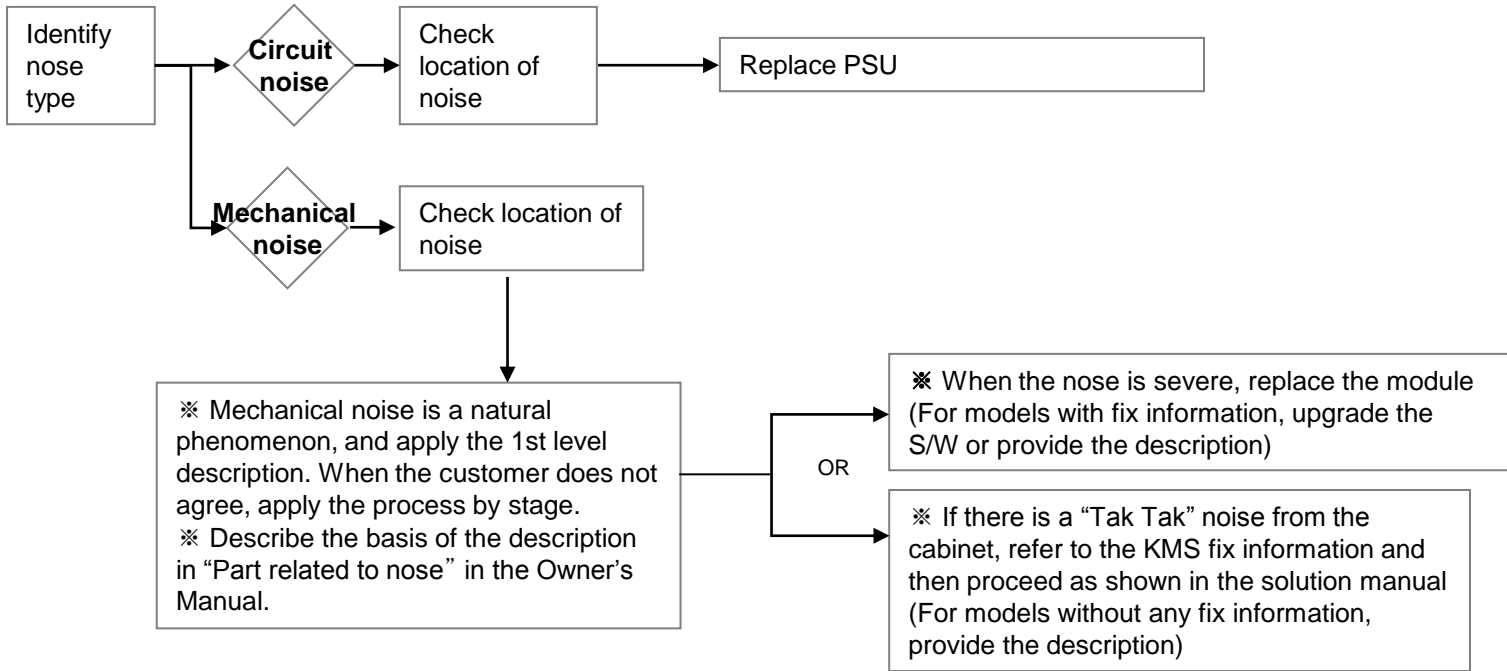

	Error symptom	F. Exterior defect	Established date		
		Exterior defect	Revised date		16/16

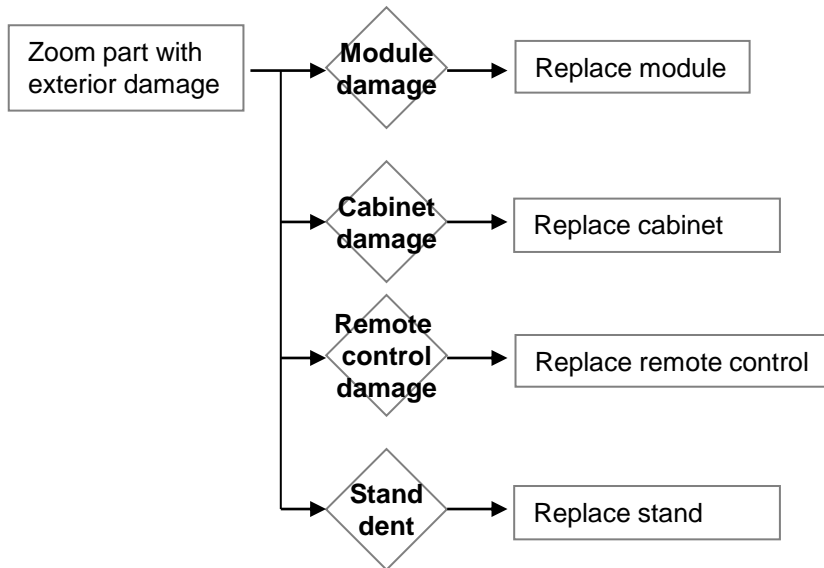

Contents of Standard Repair Process Detail Technical Manual

No.	Error symptom	Content	Page	Remarks
1	A. Video error_ No video/Normal audio	Check back light with naked eye	A1	
2		Check White Balance value	A2	
3	A. Video error_ video error /Video lag/stop	TUNER input signal strength checking method	A3	
4		Version checking method	A4	
5		Tuner Checking Part	A5	
6	A. Video error _Vertical/Horizontal bar, residual image, light spot	Connection diagram	A6	
7	A. Video error_ Color error	Check Link Cable (EPI) reconnection condition	A7	
8		Adjustment Test pattern – ADJ Key	A8	
9	<Appendix> Defected Type caused by T-Con/ Inverter/ Module	Exchange Main Board (1)	A-1/5	
10		Exchange Main Board (2)	A-2/5	
11		Exchange Power Board (PSU)	A-3/5	
12		Exchange Module (1)	A-4/5	
13		Exchange Module (2)	A-5/5	

Contents of Standard Repair Process Detail Technical Manual

No.	Error symptom	Content	Page	Remarks
14	B. Power error_ No power	Check front display LED	A17	
15		Check power input Voltage & ST-BY 3.5V	A18	
16	B. Power error_Off when on, off while viewing	POWER OFF MODE checking method	A19	
17	C. Audio error_ No audio/Normal video	Checking method in menu when there is no audio	A20	
18		Voltage and speaker checking method when there is no audio	A21	
19	E. Etc	Tool option changing method	A22	

Standard Repair Process Detail Technical Manual

	Error symptom	A. Video error_No video/Normal audio	Established date		
	Content	Check back light with naked eye	Revised date		A1

<ALL MODELS>

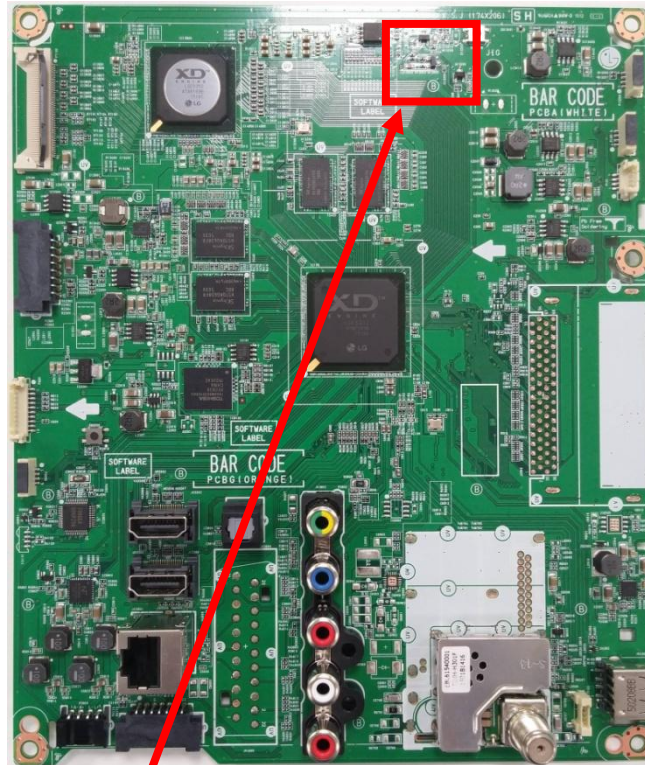

After turning on the power and disassembling the case, check with the naked eye, whether you can see light from locations.

A1

Standard Repair Process Detail Technical Manual

	Error symptom	A. Video error_No video/Normal audio	Established date		
	Content	Check White Balance value	Revised date		A2

<ALL MODELS>

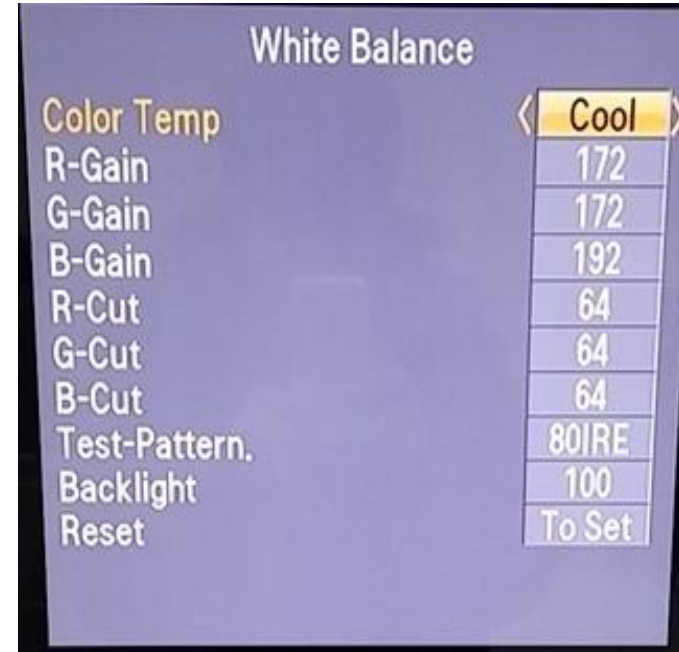
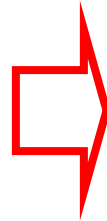
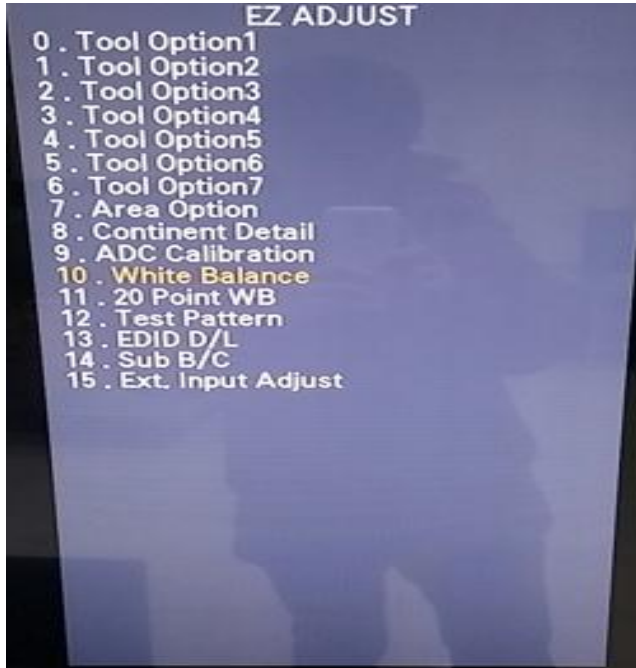

Entry method

1. Press the ADJ button on the remote control for adjustment.
2. Enter into White Balance of item 10.
3. After recording the R, G, B (GAIN, Cut) value of Color Temp (Cool/Medium/Warm), re-enter the value after replacing the MAIN BOARD.

A2

Standard Repair Process Detail Technical Manual

	Error symptom	A. Video error_Video error, video lag/stop	Established date		
	Content	TUNER input signal strength checking method	Revised date		A3

<ALL MODELS>

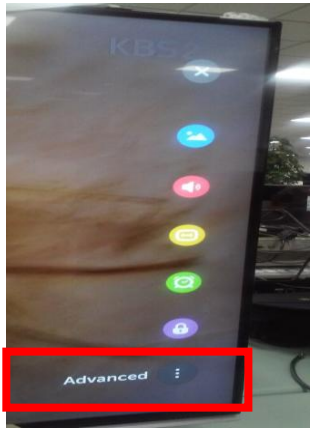

Advanced → Channels → Channel Tuning → Manual Tuning

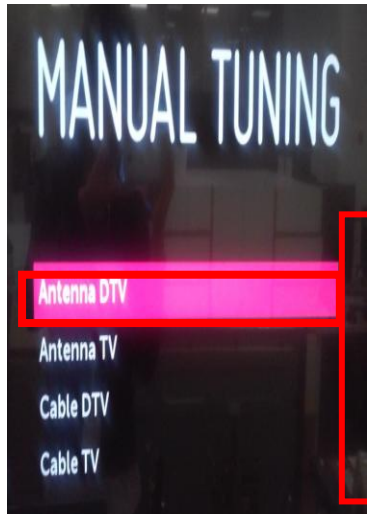
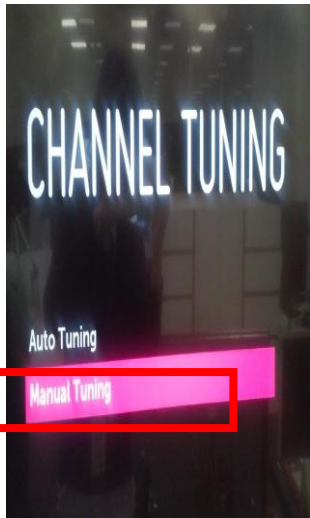

When the signal is strong, use the attenuator (-10dB, -15dB, -20dB etc.)



Standard Repair Process Detail Technical Manual

	Error symptom	A. Video error_Video error, video lag/stop	Established date		
	Content	Version checking method	Revised date		A4

<ALL MODELS>

1. Checking method for remote control for adjustment

Version

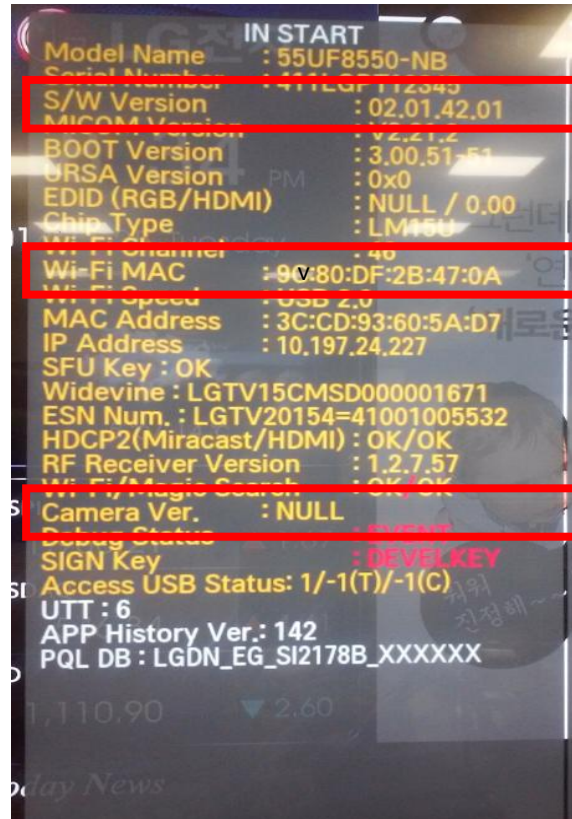

Press the IN-START with the remote control for adjustment

Standard Repair Process Detail Technical Manual

	Error symptom	A. Video error_Video error, video lag/stop	Established date		
	Content	TUNER checking part	Revised date		A5

<ALL MODELS>

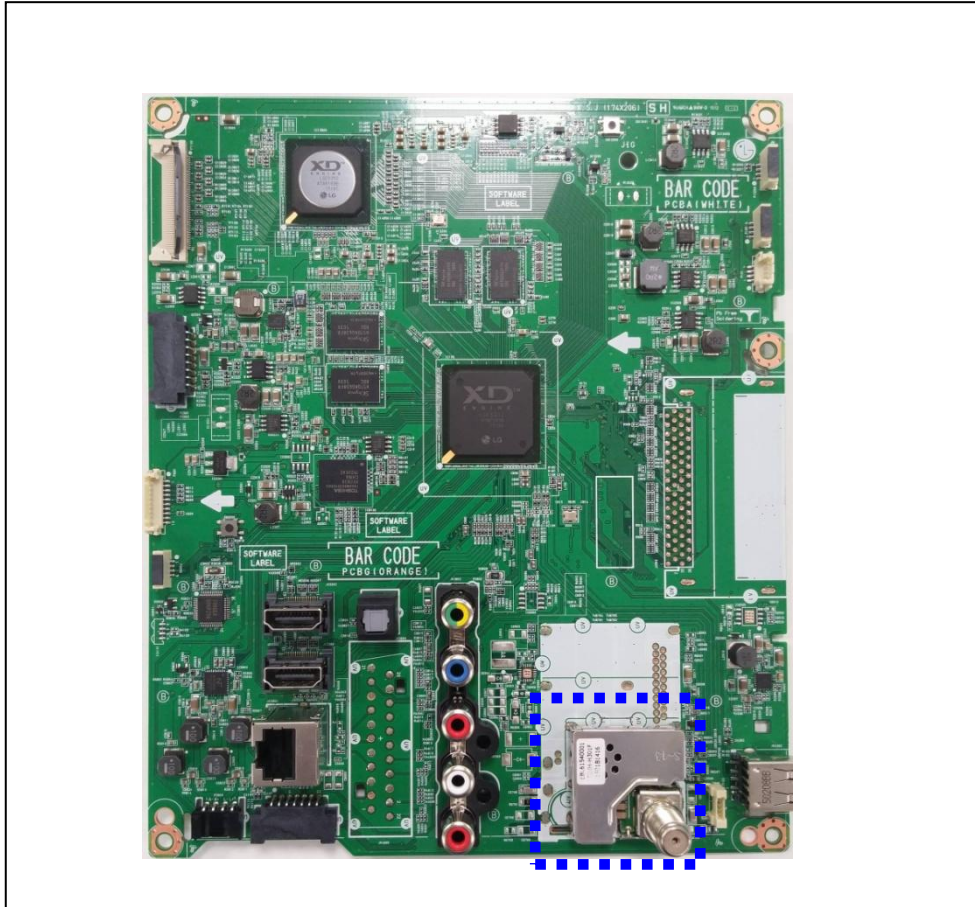

Checking method:

1. Check the signal strength or check whether the screen is normal when the external device is connected.
2. After measuring each voltage from power supply, finally replace the MAIN BOARD.
3. If you can't see the UHD live TV, please connect signal at left side of jack. (Korea model only)

Standard Repair Process Detail Technical Manual

	Error symptom	A. Video error _ Vertical/Horizontal bar, residual image, light spot	Established date		
	Content	connection diagram (1)	Revised date		A6

<ALL MODELS>

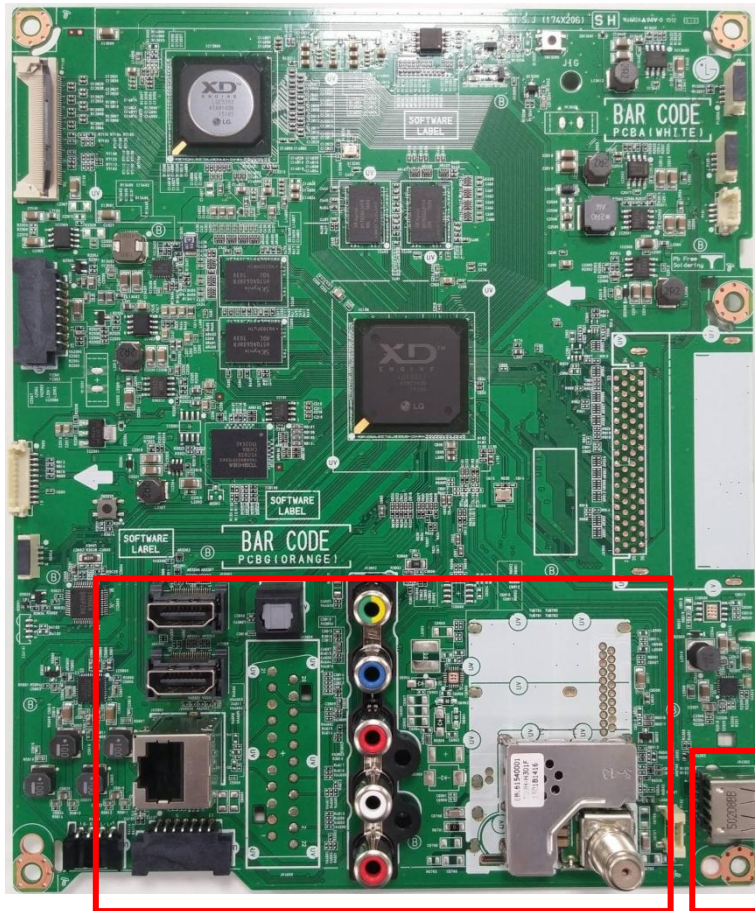

As the part connecting to the external input, check the screen condition by signal

Standard Repair Process Detail Technical Manual

	Error symptom	A. Video error_Color error	Established date		
	Content	Check Link Cable(VX1) reconnection condition	Revised date		A7

<ALL MODELS>

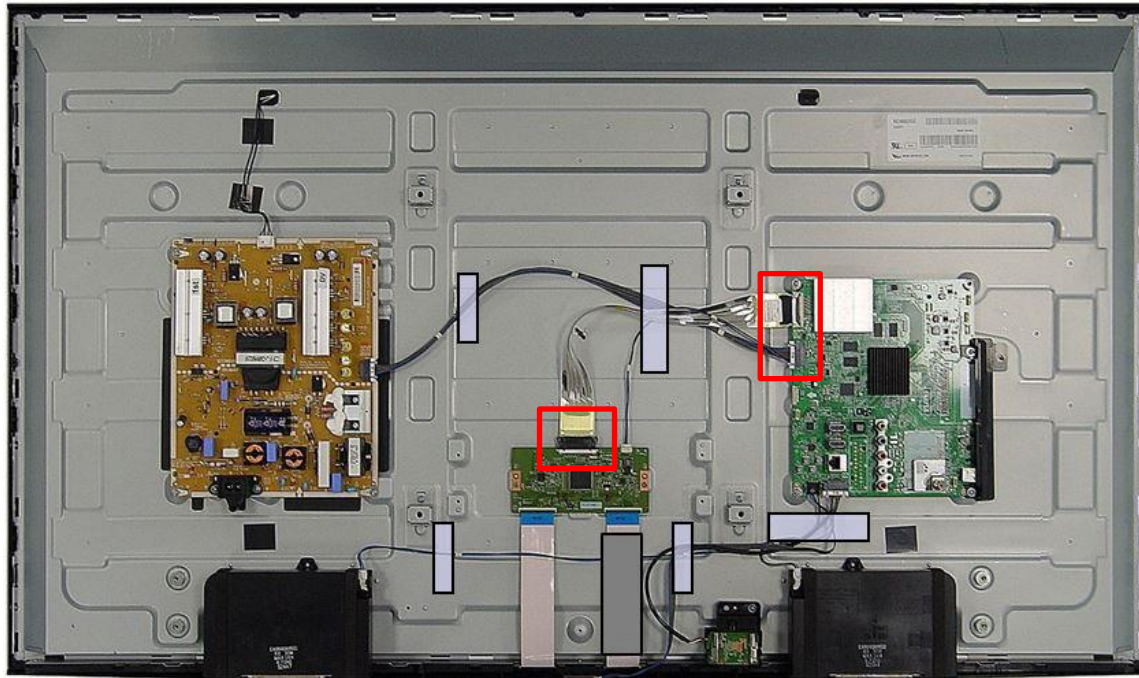

Check the contact condition of the Link Cable, especially dust or mis insertion.

A7

Standard Repair Process Detail Technical Manual

	Error symptom	A. Video error_Color error	Established date		
	Content	Adjustment Test pattern - ADJ Key	Revised date		A8

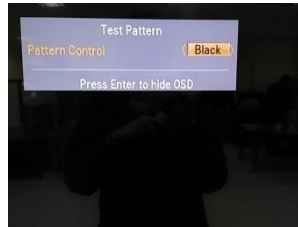
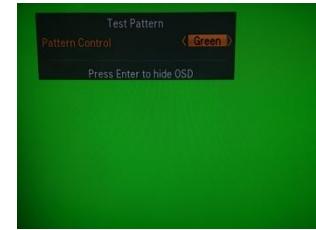
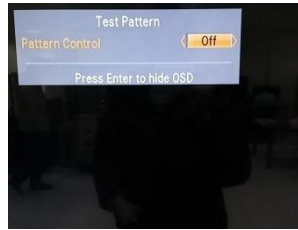
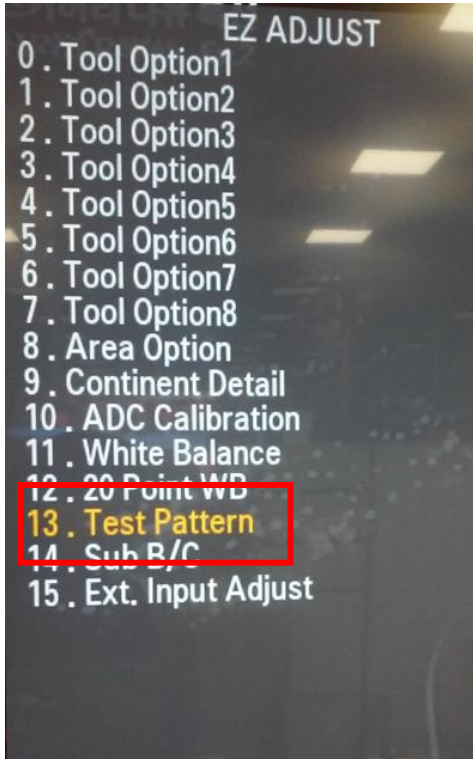

You can view 6 types of patterns using the ADJ Key

Checking item : 1. Defective pixel 2. Residual image 3. MODULE error (ADD-BAR,SCAN BAR..) 4.Video error (Classification of MODULE or Main-B/D!)

Appendix : Exchange Main Board (1)



Solder defect, CNT Broken

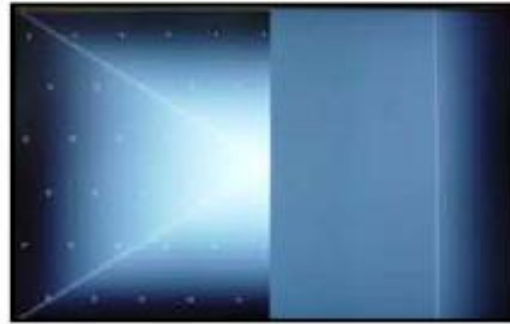

Solder defect, CNT Broken

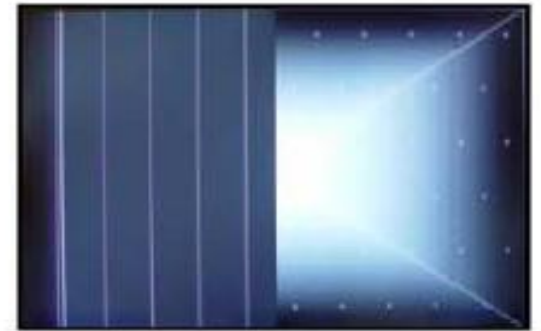

Solder defect, CNT Broken



Solder defect, CNT Broken

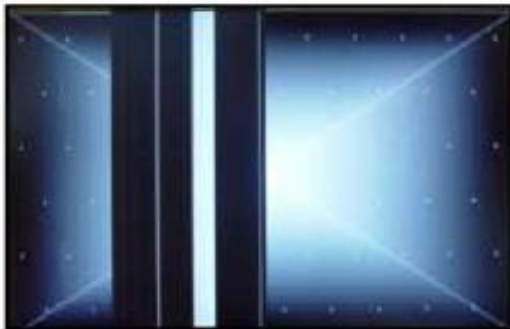

Solder defect, CNT Broken



Abnormal Power Section

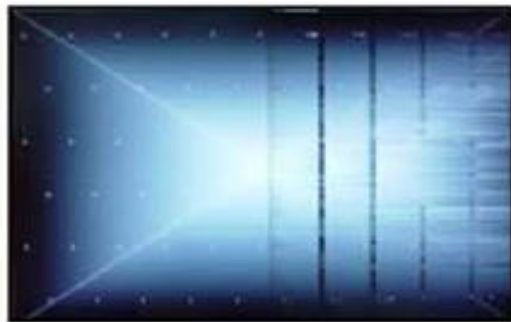

Solder defect, Short/Crack



Abnormal Power Section



Solder defect, Short/Crack

Appendix : Exchange Main Board (2)



Abnormal Power Section



Abnormal Power Section



Solder defect, Short/Crack



Solder defect, Short/Crack

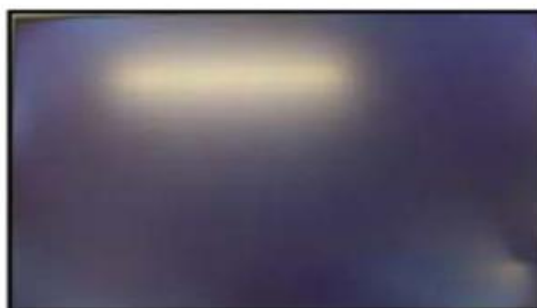

Fuse Open, Abnormal power section



Abnormal Display



GRADATION



Noise



GRADATION

Appendix : Exchange Power Board (PSU)



No Light



Dim Light

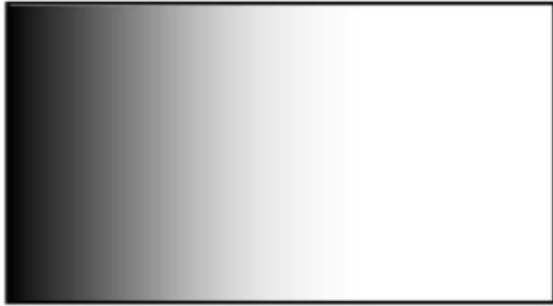

Dim Light

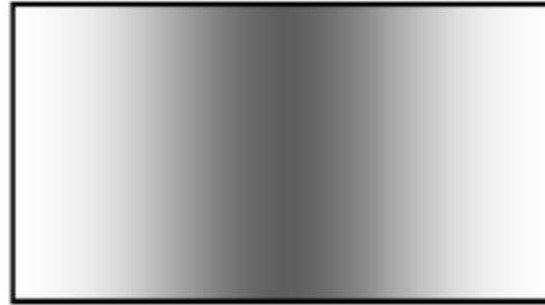

Dim Light



No picture/Sound Ok

Appendix : Exchange the Module (1)



Panel Mura, Light leakage



Panel Mura, Light leakage



Press damage

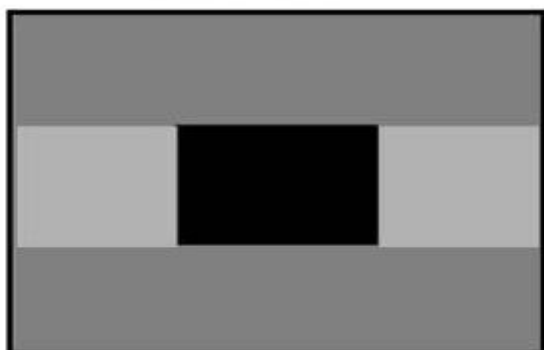

Crosstalk



Press damage



Crosstalk



Press damage

Un-repairable Cases

In this case please exchange the module.

Appendix : Exchange the Module (2)

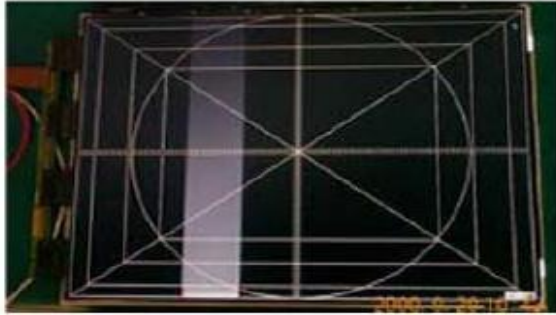

Vertical Block
Source TAB IC Defect



Vertical Line
Source TAB IC Defect



Vertical Block
Source TAB IC Defect



Horizontal Block
Gate TAB IC Defect



Horizontal Block
Gate TAB IC Defect

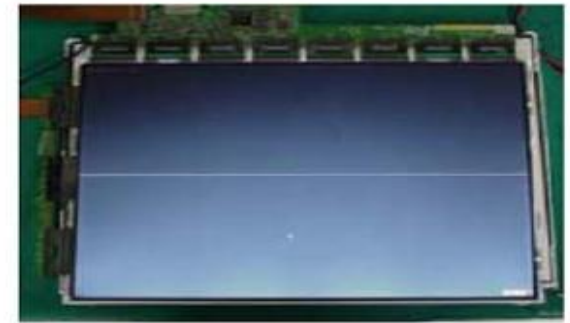

Horizontal line
Gate TAB IC Defect



Horizontal Block
Gate TAB IC Defect

Un-repairable Cases
In this case please exchange the module.

A - 5/5

Standard Repair Process Detail Technical Manual

	Error symptom	B. Power error _No power	Established date		
	Content	Check front Power Indicator	Revised date		A17

<LM14A>

ST-BY condition: On or Off
Power ON condition: Turn Off

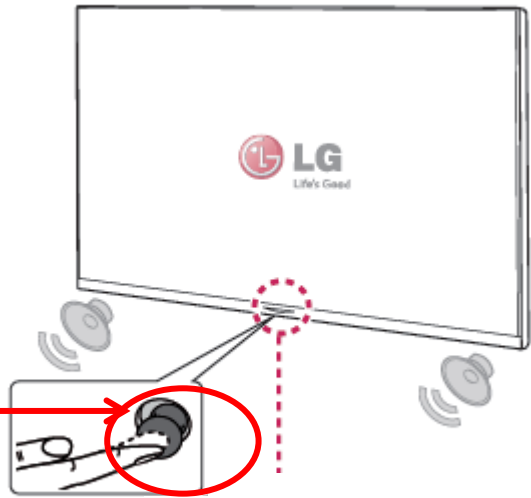

Standard Repair Process Detail Technical Manual

	Error symptom	B. Power error _No power	Established date	
	Content	Check power input voltage and ST-BY 3.5V	Revised date	A18

Check the DC 12V

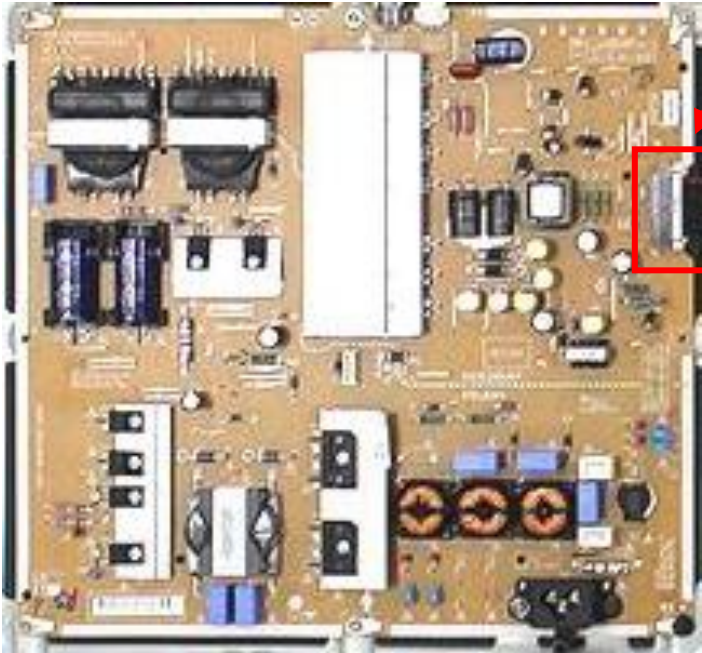

1	RL_ON	2	PWM_DIM2
3	GND	4	12V
5	12V	6	12V
7	12V	8	12V
9	GND	10	GND
11	INV_CTL	12	PWM_DIM1

A18

Standard Repair Process Detail Technical Manual

	Error symptom	B. Power error _Off when on, off whiling viewing	Established date		
	Content	POWER OFF MODE checking method	Revised date		A19

<ALL MODELS>

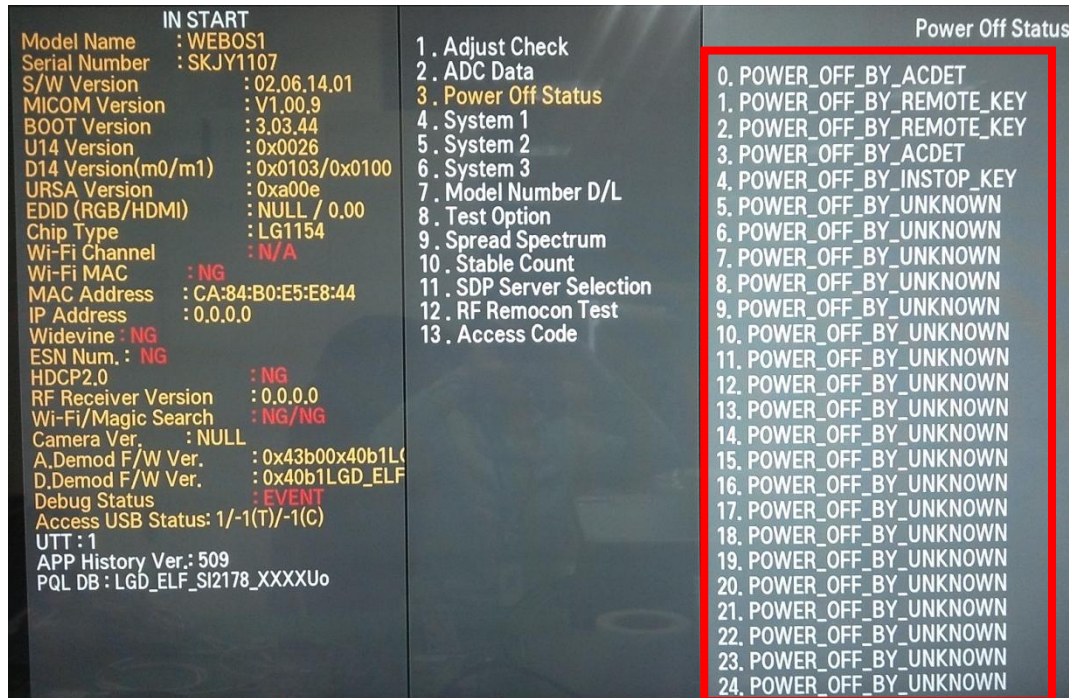

Entry method

1. Press the IN-START button of the remote control for adjustment
2. Check the entry into adjustment item 3

A19

Standard Repair Process Detail Technical Manual

	Error symptom	C. Audio error_No audio/Normal video	Established date		
	Content	Checking method in menu when there is no audio	Revised date		A20

<ALL MODELS>

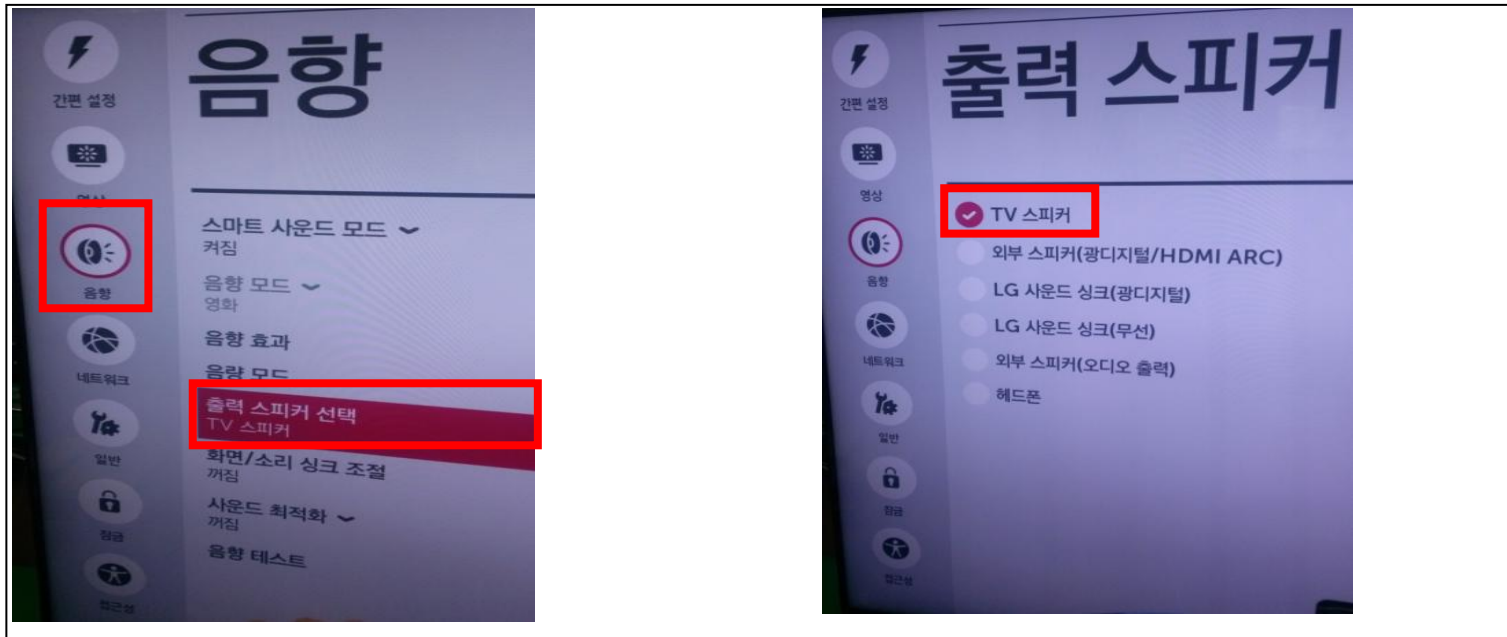

Checking method

1. Press the Setting button on the remote control
2. Select the Sound function of the Menu
3. Select the Sound Out
4. Select TV Speaker

A20

Standard Repair Process Detail Technical Manual

Error symptom	C. Audio error_No audio/Normal video	Established date		
Content	Voltage and speaker checking method when there is no audio	Revised date		A21

<All Models>



1	RL_ON	2	PWM_DIM2
3	GND	4	12V
5	12V	6	12V
7	12V	8	12V
9	GND	10	GND
11	INV_CTL	12	PWM_DIM1

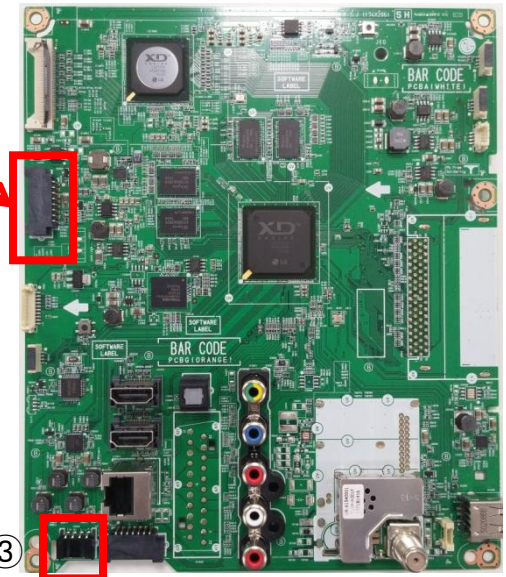

Checking order when there is no audio

1. Check the contact condition of or 12V connector of Main Board

2. Measure the 12V input voltage supplied from Power Board (If there is no input voltage, remove and check the connector)

3. Connect the tester RX1 to the speaker terminal and if you hear the Chik Chik sound when you touch the GND and output terminal, the speaker is normal.

1	SPK_R-
2	SPK_R+
3	SPK_L-
4	SPK_L+