



LG

Life's Good

Internal Use Only

LED TV

SERVICE MANUAL

CHASSIS : 6L60N

MODEL : 50UH5500

CAUTION

BEFORE SERVICING THE CHASSIS,
READ THE SAFETY PRECAUTIONS IN THIS MANUAL.

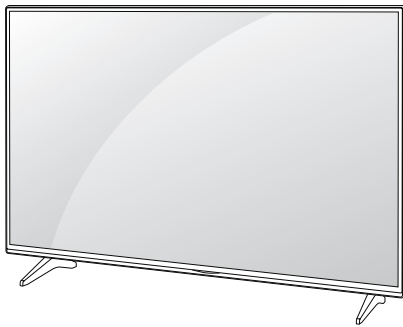

CONTENTS

CONTENTS	2
SAFETY PRECAUTIONS	3
SERVICING PRECAUTIONS	4
SPECIFICATION	6
ADJUSTMENT INSTRUCTION	14
BLOCK DIAGRAM.....	26
EXPLODED VIEW	34
DISASSEMBLY	35
SCHEMATIC CIRCUIT DIAGRAM	APPENDIX
TROUBLE SHOOTING GUIDE	APPENDIX

SAFETY PRECAUTIONS

IMPORTANT SAFETY NOTICE

Many electrical and mechanical parts in this chassis have special safety-related characteristics. These parts are identified by \triangle in the Schematic Diagram and Exploded View.

It is essential that these special safety parts should be replaced with the same components as recommended in this manual to prevent Shock, Fire, or other Hazards.

Do not modify the original design without permission of manufacturer.

General Guidance

An **isolation Transformer should always be used** during the servicing of a receiver whose chassis is not isolated from the AC power line. Use a transformer of adequate power rating as this protects the technician from accidents resulting in personal injury from electrical shocks.

It will also protect the receiver and its components from being damaged by accidental shorts of the circuitry that may be inadvertently introduced during the service operation.

If any fuse (or Fusible Resistor) in this TV receiver is blown, replace it with the specified.

When replacing a high wattage resistor (Oxide Metal Film Resistor, over 1 W), keep the resistor 10 mm away from PCB.

Keep wires away from high voltage or high temperature parts.

Before returning the receiver to the customer,

always perform an **AC leakage current check** on the exposed metallic parts of the cabinet, such as antennas, terminals, etc., to be sure the set is safe to operate without damage of electrical shock.

Leakage Current Cold Check(Antenna Cold Check)

With the instrument AC plug removed from AC source, connect an electrical jumper across the two AC plug prongs. Place the AC switch in the on position, connect one lead of ohm-meter to the AC plug prongs tied together and touch other ohm-meter lead in turn to each exposed metallic parts such as antenna terminals, phone jacks, etc.

If the exposed metallic part has a return path to the chassis, the measured resistance should be between 1 M Ω and 5.2 M Ω .

When the exposed metal has no return path to the chassis the reading must be infinite.

An other abnormality exists that must be corrected before the receiver is returned to the customer.

Leakage Current Hot Check (See below Figure)

Plug the AC cord directly into the AC outlet.

Do not use a line Isolation Transformer during this check.

Connect 1.5 K / 10 watt resistor in parallel with a 0.15 uF capacitor between a known good earth ground (Water Pipe, Conduit, etc.) and the exposed metallic parts.

Measure the AC voltage across the resistor using AC voltmeter with 1000 ohms/volt or more sensitivity.

Reverse plug the AC cord into the AC outlet and repeat AC voltage measurements for each exposed metallic part. Any voltage measured must not exceed 0.75 volt RMS which corresponds to 0.5 mA.

In case any measurement is out of the limits specified, there is possibility of shock hazard and the set must be checked and repaired before it is returned to the customer.

Leakage Current Hot Check circuit

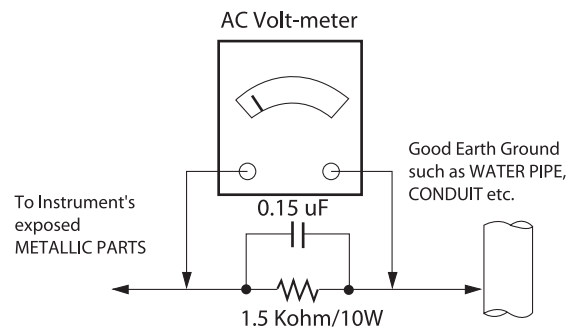

When 25A is impressed between Earth and 2nd Ground for 1 second, Resistance must be less than 0.1 Ω

*Base on Adjustment standard

SERVICING PRECAUTIONS

CAUTION: Before servicing receivers covered by this service manual and its supplements and addenda, read and follow the **SAFETY PRECAUTIONS** on page 3 of this publication.
NOTE: If unforeseen circumstances create conflict between the following servicing precautions and any of the safety precautions on page 3 of this publication, always follow the safety precautions. Remember: Safety First.

General Servicing Precautions

1. Always unplug the receiver AC power cord from the AC power source before;
 - a. Removing or reinstalling any component, circuit board module or any other receiver assembly.
 - b. Disconnecting or reconnecting any receiver electrical plug or other electrical connection.
 - c. Connecting a test substitute in parallel with an electrolytic capacitor in the receiver.
CAUTION: A wrong part substitution or incorrect polarity installation of electrolytic capacitors may result in an explosion hazard.
2. Test high voltage only by measuring it with an appropriate high voltage meter or other voltage measuring device (DVM, FETVOM, etc) equipped with a suitable high voltage probe. Do not test high voltage by "drawing an arc".
3. Do not spray chemicals on or near this receiver or any of its assemblies.
4. Unless specified otherwise in this service manual, clean electrical contacts only by applying the following mixture to the contacts with a pipe cleaner, cotton-tipped stick or comparable non-abrasive applicator; 10 % (by volume) Acetone and 90 % (by volume) isopropyl alcohol (90 % - 99 % strength)
CAUTION: This is a flammable mixture.
Unless specified otherwise in this service manual, lubrication of contacts is not required.
5. Do not defeat any plug/socket B+ voltage interlocks with which receivers covered by this service manual might be equipped.
6. Do not apply AC power to this instrument and/or any of its electrical assemblies unless all solid-state device heat sinks are correctly installed.
7. Always connect the test receiver ground lead to the receiver chassis ground before connecting the test receiver positive lead.
Always remove the test receiver ground lead last.
8. Use with this receiver only the test fixtures specified in this service manual.
CAUTION: Do not connect the test fixture ground strap to any heat sink in this receiver.

Electrostatically Sensitive (ES) Devices

Some semiconductor (solid-state) devices can be damaged easily by static electricity. Such components commonly are called Electrostatically Sensitive (ES) Devices. Examples of typical ES devices are integrated circuits and some field-effect transistors and semiconductor "chip" components. The following techniques should be used to help reduce the incidence of component damage caused by static by static electricity.

1. Immediately before handling any semiconductor component or semiconductor-equipped assembly, drain off any electrostatic charge on your body by touching a known earth ground. Alternatively, obtain and wear a commercially available discharging wrist strap device, which should be removed to prevent potential shock reasons prior to applying power to the unit under test.

2. After removing an electrical assembly equipped with ES devices, place the assembly on a conductive surface such as aluminum foil, to prevent electrostatic charge buildup or exposure of the assembly.
3. Use only a grounded-tip soldering iron to solder or unsolder ES devices.
4. Use only an anti-static type solder removal device. Some solder removal devices not classified as "anti-static" can generate electrical charges sufficient to damage ES devices.
5. Do not use freon-propelled chemicals. These can generate electrical charges sufficient to damage ES devices.
6. Do not remove a replacement ES device from its protective package until immediately before you are ready to install it. (Most replacement ES devices are packaged with leads electrically shorted together by conductive foam, aluminum foil or comparable conductive material).
7. Immediately before removing the protective material from the leads of a replacement ES device, touch the protective material to the chassis or circuit assembly into which the device will be installed.
CAUTION: Be sure no power is applied to the chassis or circuit, and observe all other safety precautions.
8. Minimize bodily motions when handling unpackaged replacement ES devices. (Otherwise harmless motion such as the brushing together of your clothes fabric or the lifting of your foot from a carpeted floor can generate static electricity sufficient to damage an ES device.)

General Soldering Guidelines

1. Use a grounded-tip, low-wattage soldering iron and appropriate tip size and shape that will maintain tip temperature within the range or 500 °F to 600 °F.
2. Use an appropriate gauge of RMA resin-core solder composed of 60 parts tin/40 parts lead.
3. Keep the soldering iron tip clean and well tinned.
4. Thoroughly clean the surfaces to be soldered. Use a small wire-bristle (0.5 inch, or 1.25 cm) brush with a metal handle. Do not use freon-propelled spray-on cleaners.
5. Use the following unsoldering technique
 - a. Allow the soldering iron tip to reach normal temperature. (500 °F to 600 °F)
 - b. Heat the component lead until the solder melts.
 - c. Quickly draw the melted solder with an anti-static, suction-type solder removal device or with solder braid.
CAUTION: Work quickly to avoid overheating the circuit board printed foil.
6. Use the following soldering technique.
 - a. Allow the soldering iron tip to reach a normal temperature (500 °F to 600 °F)
 - b. First, hold the soldering iron tip and solder the strand against the component lead until the solder melts.
 - c. Quickly move the soldering iron tip to the junction of the component lead and the printed circuit foil, and hold it there only until the solder flows onto and around both the component lead and the foil.
CAUTION: Work quickly to avoid overheating the circuit board printed foil.
 - d. Closely inspect the solder area and remove any excess or splashed solder with a small wire-bristle brush.

IC Remove/Replacement

Some chassis circuit boards have slotted holes (oblong) through which the IC leads are inserted and then bent flat against the circuit foil. When holes are the slotted type, the following technique should be used to remove and replace the IC. When working with boards using the familiar round hole, use the standard technique as outlined in paragraphs 5 and 6 above.

Removal

1. Desolder and straighten each IC lead in one operation by gently prying up on the lead with the soldering iron tip as the solder melts.
2. Draw away the melted solder with an anti-static suction-type solder removal device (or with solder braid) before removing the IC.

Replacement

1. Carefully insert the replacement IC in the circuit board.
2. Carefully bend each IC lead against the circuit foil pad and solder it.
3. Clean the soldered areas with a small wire-bristle brush. (It is not necessary to reapply acrylic coating to the areas).

"Small-Signal" Discrete Transistor Removal/Replacement

1. Remove the defective transistor by clipping its leads as close as possible to the component body.
2. Bend into a "U" shape the end of each of three leads remaining on the circuit board.
3. Bend into a "U" shape the replacement transistor leads.
4. Connect the replacement transistor leads to the corresponding leads extending from the circuit board and crimp the "U" with long nose pliers to insure metal to metal contact then solder each connection.

Power Output, Transistor Device

Removal/Replacement

1. Heat and remove all solder from around the transistor leads.
2. Remove the heat sink mounting screw (if so equipped).
3. Carefully remove the transistor from the heat sink of the circuit board.
4. Insert new transistor in the circuit board.
5. Solder each transistor lead, and clip off excess lead.
6. Replace heat sink.

Diode Removal/Replacement

1. Remove defective diode by clipping its leads as close as possible to diode body.
2. Bend the two remaining leads perpendicular y to the circuit board.
3. Observing diode polarity, wrap each lead of the new diode around the corresponding lead on the circuit board.
4. Securely crimp each connection and solder it.
5. Inspect (on the circuit board copper side) the solder joints of the two "original" leads. If they are not shiny, reheat them and if necessary, apply additional solder.

Fuse and Conventional Resistor

Removal/Replacement

1. Clip each fuse or resistor lead at top of the circuit board hollow stake.
2. Securely crimp the leads of replacement component around notch at stake top.

3. Solder the connections.

CAUTION: Maintain original spacing between the replaced component and adjacent components and the circuit board to prevent excessive component temperatures.

Circuit Board Foil Repair

Excessive heat applied to the copper foil of any printed circuit board will weaken the adhesive that bonds the foil to the circuit board causing the foil to separate from or "lift-off" the board. The following guidelines and procedures should be followed whenever this condition is encountered.

At IC Connections

To repair a defective copper pattern at IC connections use the following procedure to install a jumper wire on the copper pattern side of the circuit board. (Use this technique only on IC connections).

1. Carefully remove the damaged copper pattern with a sharp knife. (Remove only as much copper as absolutely necessary).
2. Carefully scratch away the solder resist and acrylic coating (if used) from the end of the remaining copper pattern.
3. Bend a small "U" in one end of a small gauge jumper wire and carefully crimp it around the IC pin. Solder the IC connection.
4. Route the jumper wire along the path of the out-away copper pattern and let it overlap the previously scraped end of the good copper pattern. Solder the overlapped area and clip off any excess jumper wire.

At Other Connections

Use the following technique to repair the defective copper pattern at connections other than IC Pins. This technique involves the installation of a jumper wire on the component side of the circuit board.

1. Remove the defective copper pattern with a sharp knife. Remove at least 1/4 inch of copper, to ensure that a hazardous condition will not exist if the jumper wire opens.
2. Trace along the copper pattern from both sides of the pattern break and locate the nearest component that is directly connected to the affected copper pattern.
3. Connect insulated 20-gauge jumper wire from the lead of the nearest component on one side of the pattern break to the lead of the nearest component on the other side. Carefully crimp and solder the connections.
CAUTION: Be sure the insulated jumper wire is dressed so the it does not touch components or sharp edges.

SPECIFICATION

NOTE : Specifications and others are subject to change without notice for improvement.

1. Application range

This spec sheet is applied to the LED TV used UA65R chassis

2. Test condition

Each part is tested as below without special notice.

- (1) Temperature : 25 °C ± 5 °C(77±9°F), CST : 40 °C±5 °C
- (2) Relative Humidity: 65 % ± 10 %
- (3) Power Voltage
Standard input voltage (100~240V@ 50/60Hz)
* Standard Voltage of each products is marked by models.
- (4) Specification and performance of each parts are followed each drawing and specification by part number in accordance with BOM.
- (5) The receiver must be operated for about 20 minutes prior to the adjustment.

3. Test method

- (1) Performance: LGE TV test method followed
- (2) Demanded other specification
 - Safety : UL, CSA, CE, IEC specification
 - EMC : FCC, ICES, CE, IEC specification
 - Wireless : Wireless HD Specification (Option)

4. General Specification

4.1. Model Specification

No	Item		Specification	Remark
1	Market		North America	
2	Broadcasting system		ATSC / NTSC-M, 64 & 256 QAM	
3	Available Channel		VHF : 2~13	
			UHF : 14~69	
			DTV : 2-69	
			CATV : 1 ~ 135	
			CADTV : 1 ~ 135	
4	Receiving system		Digital : ATSC, 64 & 256 QAM Analog : NTSC-M	
5	Video Input		NTSC-M	Rear RCA
6	Component Input		Y/Cb/Cr, Y/ Pb/Pr	Rear RCA
7	HDMI Input	HDMI 3	DTV format, Support HDCP2.2/ PC (HDMI version 1.4)	Side,
		HDMI 2	DTV format, Support HDCP2.2/ PC (HDMI version 1.4/2.0)	Side, Support ARC only HDMI2
		HDMI 1	DTV format, Support HDCP2.2/ PC (HDMI version 1.4/2.0)	Side,
8	Audio Input		Component / AV Audio	L/R Input ; Rear Component and av use same jack ; Rear
9	SPDIF out(1EA)		Optical Audio out	Rear (1EA),
10	USB Input(3EA)		EMF, DivX HD, For SVC (download)	Side(1)/Rear(2) :JPEG, MP3, DivX HD (Exception, UA65S: USB 1EA)

4.2. Module Specification

No	Item	Specification		Remark
1	Display Screen Device	50" wide color display module		Module name: 7626-T5000Q-Y340
2	Aspect Ratio	16:9		All
4	Operating Environment	TFT	1) Temp. : 0 ~ 40 deg 2) Humidity : 0 ~ 85%	LGE SPEC
		ALEF	Temp. : 0 ~ 50 deg Humidity : 20 ~ 90%	
5	Storage Environment	TFT	Temp. : -20 ~ 60 deg Humidity : 10 ~ 90%	
		ALEF	Temp. : -20 ~ 60 deg Humidity : 10 ~ 90%	
6	Input Voltage	AC100 ~ 240V, 50/60Hz		
7	Display Colors	1.07 B (10-bit)		LGD
		1.07G colors (8-bit+FRC)		V580DJ2-KS5
		1.067G		V500DJ2-KS5
	Surface Treatment	Hard coating (2H), Anti-glare		

5. External input format

5.1. 2D Mode

5.1.1. Component input(Y, CB/PB, CR/PR)

No	Resolution	H-freq(kHz)	V-freq.(Hz)	Pixel clock(MHz)	Proposed
1	720*480	15.73	60	13.5135	SDTV ,DVD 480I
2	720*480	15.73	59.94	13.5	SDTV ,DVD 480I
3	720*480	31.50	60	27.027	SDTV 480P
4	720*480	31.47	59.94	27.0	SDTV 480P
5	1280*720	45.00	60.00	74.25	HDTV 720P
6	1280*720	44.96	59.94	74.176	HDTV 720P
7	1920*1080	33.75	60.00	74.25	HDTV 1080I
8	1920*1080	33.72	59.94	74.176	HDTV 1080I
9	1920*1080	67.500	60	148.50	HDTV 1080P
10	1920*1080	67.432	59.94	148.352	HDTV 1080P

5.1.2. HDMI Input (PC/DTV)

No.	Resolution	H-freq(kHz)	V-freq.(kHz)	Pixel clock(MHz)	Proposed	
	HDMI-PC					DDC
1	640*350	31.46	70.09	25.17	EGA	X
2	720*400	31.46	70.08	28.32	DOS	O
3	640*480	31.46	59.94	25.17	VESA(VGA)	O
4	800*600	37.87	60.31	40.00	VESA(SVGA)	O
5	1024*768	48.36	60.00	65.00	VESA(XGA)	O
6	1152*864	54.34	60.05	80.00	VESA	O
7	1280*1024	63.98	60.02	108.00	VESA (SXGA)	O
8	1360*768	47.71	60.01	85.50	VESA (WXGA)	O
9	1920*1080	67.5	60	148.5	WUXGA(Reduced Blanking)	O
10	3840*2160	67.5	30	297.00	Only UD Model	O
11	3840*2160	56.25	25.00	297.00	Only UD Model	O
12	3840*2160	54	24	297.00	Only UD Model	O
13	4096*2160	53.95	23.97	297	Only UD Model	O
14	4096*2160	54	24	297	Only UD Model	O

	HDMI-DTV				
1	640 * 480	31.46	59.94	25.125	SDTV 480P
2	640 * 480	31.5	60	25.125	SDTV 480P
3	720 * 480	31.5	60	27.027	SDTV 480P
4	720 * 480	31.47	59.94	27.00	SDTV 480P
5	1280*720	45.00	60.00	74.25	HDTV 720P
6	1280*720	44.96	59.94	74.176	HDTV 720P
7	1920*1080	33.75	60.00	74.25	HDTV 1080I
8	1920*1080	33.72	59.94	74.176	HDTV 1080I
9	1920*1080	67.50	60	148.50	HDTV 1080P
10	1920*1080	67.43	59.94	148.35	HDTV 1080P
11	1920*1080	27.00	24.00	74.25	HDTV 1080P
12	1920*1080	26.97	23.97	74.176	HDTV 1080P
13	1920*1080	33.75	30.00	74.25	HDTV 1080P
14	1920*1080	33.71	29.97	74.176	HDTV 1080P
15	3840*2160	67.5	30.00	297.00	UDTV 2160P
16	3840*2160	61.43	29.97	296.703	UDTV 2160P
17	3840*2160	56.25	25.00	297.00	UDTV 2160P
18	3840*2160	54.0	24.00	297.00	UDTV 2160P
19	3840*2160	53.95	23.98	296.703	UDTV 2160P
20	3840*2160	135	59.94	594	UDTV 2160P
21	3840*2160	135	60	594	UDTV 2160P
22	4096*2160	53.95	23.98	296.703	UDTV 2160P
23	4096*2160	54	24.00	297	UDTV 2160P
24	4096*2160	56.25	25.00	297	UDTV 2160P
25	4096*2160	61.43	29.97	296.703	UDTV 2160P
26	4096*2160	67.5	30.00	297	UDTV 2160P
27	4096*2160	135	59.94	594	UDTV 2160P
28	4096*2160	135	60.00	594	UDTV 2160P

5.2. 3D Mode

5.2.1. HDMI Input 1.4b (3D supported mode automatically)

No	Resolution	H-freq(kHz)	V-freq.(Hz)	Pixel clock (MHz)	VIC	3D input proposed mode	Proposed
1	640*480	31.46 / 31.5	59.94/ 60	25.17/25.2	1	Top-and-Bottom Side-by-side(half)	Secondary(SDTV 480P) Secondary(SDTV 480P)
		62.93 / 63	59.94/ 60	50.35/50.4	1	Frame packing Line alternative	Secondary(SDTV 480P) (SDTV 480P)
		31.46 / 31.5	59.94/ 60	50.35/50.4	1	Side-by-side(Full)	(SDTV 480P)
2	720*480	31.46 / 31.5	59.94 / 60	27.00/27.03	2,3	Top-and-Bottom Side-by-side(half)	Secondary(SDTV 480P) Secondary(SDTV 480P)
		62.93 / 63	59.94 / 60	54/54.06	2,3	Frame packing Line alternative	Secondary(SDTV 480P) (SDTV 480P)
		31.46 / 31.5	59.94 / 60	54/54.06	2,3	Side-by-side(Full)	(SDTV 480P)
3	1280*720	44.96 / 45	59.94 / 60	74.18/74.25	4	Top-and-Bottom Side-by-side(half)	Primary(HDTV 720P) Primary(HDTV 720P)
		89.91 / 90	59.94 / 60	148.35/148.5	4	Frame packing Line alternative	Primary(HDTV 720P) (HDTV 720P)
		44.96 / 45	59.94 / 60	148.35/148.5	4	Side-by-side(Full)	(HDTV 720P)
4	1920*1080	33.72 / 33.75	59.94 / 60	74.18/74.25	5	Top-and-Bottom Side-by-side(half)	Secondary(HDTV 1080I) Primary(HDTV 1080I)
		67.43 / 67.5	59.94 / 60	148.35/148.5	5	Frame packing Field alternative	Primary(HDTV 1080I) (HDTV 1080I)
		33.72 / 33.75	59.94 / 60	148.35/148.5	5	Side-by-side(Full)	(HDTV 1080I)
		26.97 / 27	23.97 / 24	74.18/74.25	32	Top-and-Bottom Side-by-side(half)	Primary(HDTV 1080P) Primary(HDTV 1080P)
		43.94 / 54	23.97 / 24	148.35/148.5	32	Frame packing Line alternative	Primary(HDTV 1080P) (HDTV 1080P)
		26.97 / 27	23.97 / 24	148.35/148.5	32	Side-by-side(Full)	(HDTV 1080P)
		28.125	25	74.25	33	Top-and-Bottom Side-by-side(half)	Secondary(HDTV 1080P) Secondary(HDTV 1080P)
		56.25	25	148.5	33	Frame packing Line alternative	Secondary(HDTV 1080P) (HDTV 1080P)
		28.125	25	148.5	33	Side-by-side(Full)	(HDTV 1080P)
		33.716 / 33.75	29.976 / 30.00	74.18/74.25	34	Top-and-Bottom Side-by-side(half)	Primary(HDTV 1080P) Secondary(HDTV 1080P)
		67.432 / 67.5	29.976 / 30.00	148.35/148.5	34	Frame packing Line alternative	Primary(HDTV 1080P) (HDTV 1080P)
		33.716 / 33.75	29.976 / 30.00	148.35/148.5	34	Side-by-side(Full)	(HDTV 1080P)
67.43 / 67.5	59.94 / 60	148.35/148.50	16	Top-and-Bottom Side-by-side(half)	Primary(HDTV 1080P) Secondary(HDTV 1080P)		

5.2.2. HDMI 1.4/2.0(3D Supported mode manually)

No	Resolution	H-freq(kHz)	V-freq.(Hz)	Pixel clock (MHz)	Proposed	3D input proposed mode
1.	720*480	31.5	60	27.03	SDTV 480P	2D to 3D, Side by Side(Half), Top & Bottom, Checker Board, Frame Sequential, Row Interleaving, Column Interleaving
2.	1280*720	45.00	60.00	74.25	HDTV 720P	
3.	1920*1080	33.75	60.00	74.25	HDTV 1080I	2D to 3D, Side by Side(Half), Top & Bottom
4.	1920*1080	27.00	24.00	74.25	HDTV 1080P	2D to 3D, Side by Side(Half), Top & Bottom, Checker Board, Row Interleaving, Column Interleaving
5.	1920*1080	28.12	25	74.25	HDTV 1080P	
6.	1920*1080	33.75	30.00	74.25	HDTV 1080P	
7.	1920*1080	67.50	60.00	148.5	HDTV 1080P	2D to 3D, Side by Side(Half), Top & Bottom, Checker Board, Single Frame Sequential, Row Interleaving, Column Interleaving
8.	3840*2160	53.95	23.976	296.703	HDTV 2160P	
9.	3840*2160	54	24.00	297.00	HDTV 2160P	
10.	3840*2160	56.25	25.00	297.00	HDTV 2160P	
11.	3840*2160	61.43	29.970	296.703	HDTV 2160P	
12.	3840*2160	67.5	30.00	297.00	HDTV 2160P	
13.	4096*2160	53.95	23.976	296.703	HDTV 2160P	
14.	4096*2160	54	24.00	297.00	HDTV 2160P	
15.	4096*2160	56.25	25.00	297.00	HDTV 2160P	
16.	4096*2160	61.43	29.970	296.703	HDTV 2160P	
17.	4096*2160	67.5	30.00	297.00	HDTV 2160P	
18.	3840*2160	135	60	594	HDTV 2160P	2D to 3D, Top & Bottom(half), Side by Side(half), Port3 Only
19.	4096*2160	135	60	594	HDTV 2160P	2D to 3D, Top & Bottom(half), Side by Side(half), Port3 Only

5.2.3. HDMI-PC Input (3D) (3D Supported Mode Manually)

No	Resolution	H-freq(kHz)	V-freq.(Hz)	Pixel clock (MHz)	Proposed	3D input proposed mode
1.	1024*768	48.36	60	65	HDTV 768P	2D to 3D, Side by Side(half), Top & Bottom
2.	1360*768	47.71	60	85.5	HDTV 768P	2D to 3D, Side by Side(half), Top & Bottom
3.	1920*1080	67.500	60	148.50	HDTV 1080P	2D to 3D, Side by Side(half), Top & Bottom, Checker Board, Single Frame Sequential, Row Interleaving, Column Interleaving
4.	3840*2160 4096*2160	54	24.00	296.703	HDTV 2160P	2D to 3D, Top & Bottom(half), Side by Side(half),
		56.25	25.00	297		
		67.5	30.00	296.703		
5.	3840*2160 4096*2160	135	60	594	HDTV 2160P	2D to 3D, Top & Bottom(half), Side by Side(half), Port3 Only
6.	Others	-	-	-	640*350 720*400 640*480 800*600 1152*864	2D to 3D, Side by Side(half), Top & Bottom

5.2.4. RF Input(3D supported mode manually)

No.	Resolution	H-freq(kHz)	V-freq.(Hz)	Pixel clock(MHz)	Proposed	3D input proposed mode
1	1280*720	37.500	50	74.25	HDTV 720P	2D to 3D, Side by Side, Top & Bottom
2	1920*1080	28.125	50	74.25	HDTV 1080I	2D to 3D, Side by Side, Top & Bottom

5.2.5. RF Input (3D supported mode automatically)

No.	Signal	3D input proposed mode
1	Frame Compatible	Side by Side(Half), Top & Bottom

5.2.6. USB, DLNA (Movie) Input (3D supported mode manually)

No.	Resolution	H-freq(kHz)	V-freq.(Hz)	Pixel clock(MHz)	3D input proposed mode
1	Under 704x480	-	-	-	2D to 3D
2	Over 704x480 interlaced	-	-	-	2D to 3D, Side by Side(Half), Top & Bottom
3	Over 704x480 progressive	-	60	-	2D to 3D, Side by Side(Half), Top & Bottom, Checker Board, Row Interleaving, Column Interleaving, Frame Sequential
4	Over 704x480 progressive	-	others	-	2D to 3D, Side by Side(Half), Top & Bottom, Checker Board, Row Interleaving, Column Interleaving
5	Over 2160P	-	24/25/30/60	-	2D to 3D, Side by Side(Half), Top & Bottom, USB Only

5.2.7. USB, DLNA (Photo) Input (3D supported mode manually)

No	Resolution	H-freq(kHz)	V-freq.(Hz)	Pixel clock(MHz)	3D input proposed mode
1	USB(Photo)	-	-	-	2D to 3D, Side by Side(Half), Top & Bottom

5.2.8. USB, DNLA Input (3D supported mode automatically)

No	Resolution	H-freq(kHz)	V-freq.(Hz)	Pixel clock(MHz)	3D input proposed mode
1	1080P	33.75	30	-	Side by Side(Half), Top & Bottom, Checker Board, MPO(Photo)
2	2160p	67.5	30	297	MPO(Photo), JPS(Photo)



5.2.9. Component Input(3D supported mode manually)

No.	Resolution	H-freq(kHz)	V-freq.(Hz)	Pixel clock(MHz)	Proposed	Remark
1	1280*720	45.00	60.00	74.25	HDTV 720P	2D to 3D, Side by Side(Half), Top & Bottom
2	1280*720	37.500	50	74.25	HDTV 720P	
3	1920*1080	33.75	60.00	74.25	HDTV 1080I	
4	1920*1080	28.125	50.00	74.25	HDTV 1080I	
5	1920*1080	27.00	24.00	74.25	HDTV 1080P	
6	1920*1080	28.12	25	74.25	HDTV 1080P	
7	1920*1080	33.75	30.00	74.25	HDTV 1080P	
8	1920*1080	67.50	60.00	148.5	HDTV 1080P	
9	1920*1080	56.250	50	148.5	HDTV 1080P	
10	Others	-	-	-	SDTV	

5.2.10. Miracast, Widi (3D supported mode manually)

No	Resolution	H-freq(kHz)	V-freq.(Hz)	Pixel clock(MHz)	3D input proposed mode
1	1024X768p	-	30 / 60	-	2D to 3D, Side by Side(Half), Top & Bottom
2	1280x720p	-	30 / 60	-	
3	1920X1080p	-	30 / 60	-	
4	Others	-	-	-	2D to 3D

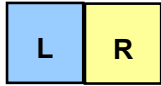
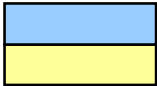
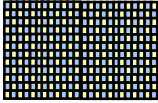
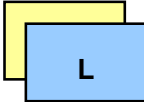
**Remark: 3D Input mode

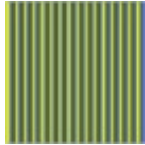
No.	Side by Side	Top & Bottom	Checkerboard	Single Frame Sequential	Frame Packing	Line Interleaving	Column Interleaving
1							

4.2. MAC address, ESN, Widevine, HDCP2.0 key D/L

4.2.1. Equipment & Condition

- (1) Play file: keydownload.exe

4.2.2. Communication Port connection

- (1) Key Write: Com 1,2,3,4 and 115200 (Baudrate)
- (2) Barcode: Com 1,2,3,4 and 9600 (Baudrate)

4.2.3. Download process

- (1) Select the download items.
- (2) Mode check: Online Only
- (3) Check the test process : DETECT -> MAC -> Widevine
- (4) Play: START
- (5) Check of result: Ready, Test, OK or NG

4.2.4. Communication Port connection

- (1) Connect: PCBA Jig -> RS-232C Port == PC -> RS-232C Port

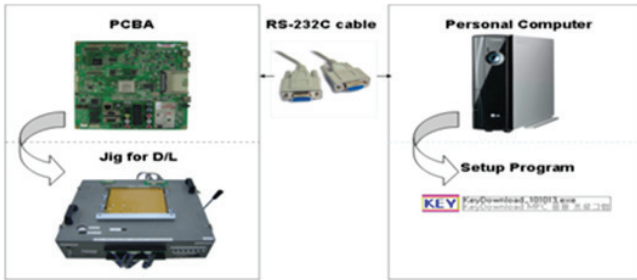

4.2.5. Download

- (1) Models(MAC + Widevine + ESN): Korea model(K2Lp)

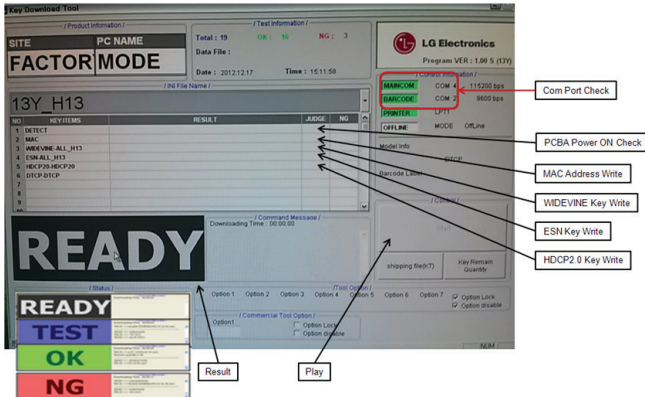

4.3. LAN Inspection

4.3.1. Equipment & Condition

- Each other connection to LAN Port of IP Hub and Jig

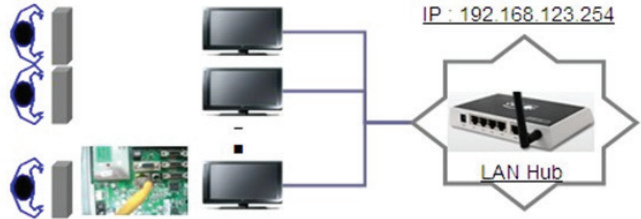

4.3.2. LAN inspection solution

- LAN Port connection with PCB
- Network setting at MENU Mode of TV
- Setting automatic IP
- Setting state confirmation
 - If automatic setting is finished, you confirm IP and MAC Address.

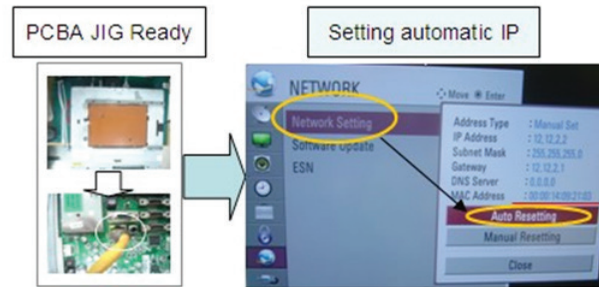

4.3.3. LAN PORT INSPECTION (PING TEST)

Connect: SET -> LAN Port == PC -> LAN Port



- (1) Play the LAN Port Test PROGRAM.
- (2) Input IP set up for an inspection to Test Program.
 - * IP Number : 12.12.2.2.

4.3.4. LAN PORT inspection (PING TEST)

- (1) Play the LAN Port Test Program.
- (2) connect each other LAN Port Jack.
- (3) Play Test (F9) button and confirm OK Message.
- (4) remove LAN CABLE



4.4. Model name & Serial number Download

4.4.1. Model name & Serial number D/L

- Press "Power on" key of service remocon.(Baud rate : 115200 bps)
- Connect RS-232C Signal to USB Cable to USB.
- Write Serial number by use USB port.
- Must check the serial number at Instart menu.

■ Method & Notice

- A. Serial number D/L is using of scan equipment.
- B. Setting of scan equipment operated by Manufacturing Technology Group.
- C. Serial number D/L must be conformed when it is produced in production line, because serial number D/L is mandatory by D-book 4.0

* Manual Download (Model Name and Serial Number)

If the TV set is downloaded By OTA or Service man, Sometimes model name or serial number is initialized. (not always)

It is impossible to download by bar code scan, so It need Manual download.

- a. Press the 'INSTART' key of ADJ remote controller.
- b. Go to the menu '7. Model Number D/L' like below photo.
- c. Input the Factory model name or Serial number like below photo.

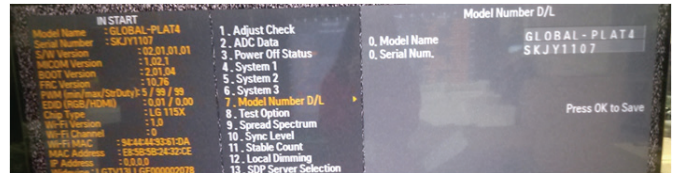

- d. Check the model name INSTART menu -> Factory name displayed
- e. Check the Diagnostics (DTV country only) -> Buyer model displayed

4.5. WIFI MAC ADDRESS CHECK

4.5.1. Using RS232 Command

	Command	Set ACK
Transmission	[A][J][Set ID][20][Cr]	[O][K][x] or [N][G]

- Check the menu on in-start

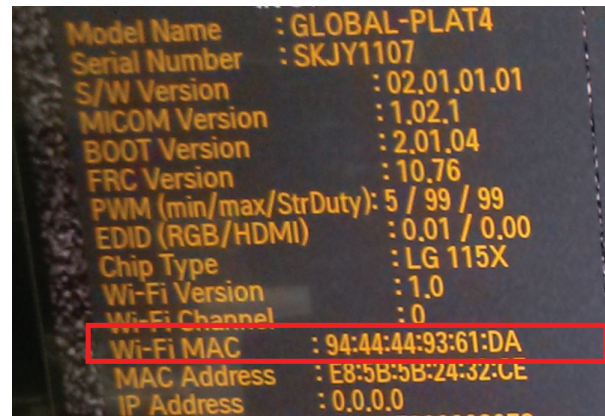

5. Manual Adjustment

5.1. ADC adjustment is not needed because of OTP (Auto ADC adjustment)

5.2. EDID

(The Extended Display Identification Data) / DDC (Display Data Channel) download

5.2.1. Overview

It is a VESA regulation. A PC or a MNT will display an optimal resolution through information sharing without any necessity of user input. It is a realization of "Plug and Play".

5.2.2. Equipment

- Since embedded EDID data is used, EDID download JIG, HDMI cable and D-sub cable are not need.
- Adjust remocon

5.2.3. Download method

- (1) Press Adj. key on the Adjust remocon, then select "12.EDID D/L".
By pressing Enter key, enter EDID D/L menu
- (2) Select [Start] button by pressing Enter key, HDMI1 / HDMI2 / HDMI3 / HDMI4 are Writing and display OK or NG.



5.2.4. EDID DATA

- Reference
- HDMI1 ~ HDMI3
- In the data of EDID, bellows may be different by Input mode

	0	1	2	3	4	5	6	7	8	9	A	B	C	D	E	F
0x00	00	FF	FF	FF	FF	FF	FF	00	1E	6D	ⓐ		ⓑ			
0x01	ⓒ		01	03	80	A0	5A	78	0A	EE	91	A3	54	4C	99	26
0x02	0F	50	54	A1	8	00	31	40	45	40	61	40	71	40	81	80
0x03	01	01	01	01	01	01	02	3A	80	18	71	38	2D	40	58	2C
0x04	45	00	40	84	63	00	00	1E	66	21	50	B0	51	00	1B	30
0x05	40	70	36	00	40	84	63	00	00	1E	00	00	00	FD	00	3A
0x06	3E	1E	53	10	00	0A	20	20	20	20	20	20	ⓓ			
0x07	ⓔ														01	ⓕ
0x00	02	03	3A	F1	4E	10	9F	04	13	05	14	03	02	12	20	21
0x01	22	15	01	29	3D	06	C0	15	07	50	ⓖ					
0x02	ⓗ															
0x03	ⓙ		10	28	10	E3	05	03	01	02	3A	80	18	71	38	
0x04	2D	40	58	2C	45	00	40	84	63	00	00	1E	01	1D	80	18
0x05	71	1C	16	20	58	2C	25	00	40	84	63	00	00	9E	01	1D
0x06	00	72	51	D0	1E	20	6E	28	55	00	40	84	63	00	00	1E
0x07	00	00	00	00	00	00	00	00	00	00	00	00	00	00	00	ⓚ

- ⓐ Product ID
- ⓑ Serial No: Controlled on production line.
- ⓒ Month, Year: Controlled on production line:
ex) Monthly : '01' -> '01'
Year : '2016' -> '1A'
- ⓓ Model Name(Hex): LGTV
- ⓔ Checksum(LG TV): Changeable by total EDID data.
- ⓕ Vendor Specific(HDMI)

5.2.4.1. EDID

DTS HDMI1 (C/S: 9F,B6)_6G_UHD Deep Color ON
EDID Block 0, Bytes 0-127

	0	1	2	3	4	5	6	7	8	9	A	B	C	D	E	F
0	00	FF	FF	FF	FF	FF	FF	00	1E	6D	01	00	01	01	01	01
10	01	1A	01	03	80	A0	5A	78	0A	EE	91	A3	54	4C	99	26
20	0F	50	54	A1	08	00	31	40	45	40	61	40	71	40	81	80
30	01	01	01	01	01	01	08	E8	00	30	F2	70	5A	80	B0	58
40	8A	00	40	84	63	00	00	1E	02	3A	80	18	71	38	2D	40
50	58	2C	45	00	40	84	63	00	00	1E	00	00	00	FD	00	3A
60	3E	1E	88	3C	00	0A	20	20	20	20	20	20	00	00	00	FC
70	00	4C	47	20	54	56	0A	20	20	20	20	20	20	20	01	9F
	0	1	2	3	4	5	6	7	8	9	A	B	C	D	E	F
0	02	03	3A	F1	50	61	90	22	20	05	04	03	02	01	5D	5E
10	5F	66	62	63	64	29	3D	06	C0	15	07	50	09	57	07	6E
20	03	0C	00	10	00	B8	3C	20	00	80	01	02	03	04	67	D8
30	5D	C4	01	78	80	03	E3	05	C0	00	E3	0F	01	10	E3	06
40	07	01	01	1D	80	18	71	1C	16	20	58	2C	25	00	40	84
50	63	00	00	9E	66	21	50	B0	51	00	1B	30	40	70	36	00
60	40	84	63	00	00	1E	00	00	00	00	00	00	00	00	00	00
70	00	00	00	00	00	00	00	00	00	00	00	00	00	00	00	B6

#DTS HDMI1 (C/S: 9F, 11)_3G_UHD Deep Color OFF
EDID Block 0, Bytes 0-127

	0	1	2	3	4	5	6	7	8	9	A	B	C	D	E	F
0	00	FF	FF	FF	FF	FF	FF	00	1E	6D	01	00	01	01	01	01
10	01	1A	01	03	80	A0	5A	78	0A	EE	91	A3	54	4C	99	26
20	0F	50	54	A1	08	00	31	40	45	40	61	40	71	40	81	80
30	01	01	01	01	01	01	08	E8	00	30	F2	70	5A	80	B0	58
40	8A	00	40	84	63	00	00	1E	02	3A	80	18	71	38	2D	40
50	58	2C	45	00	40	84	63	00	00	1E	00	00	00	FD	00	3A
60	3E	1E	88	3C	00	0A	20	20	20	20	20	20	00	00	00	FC
70	00	4C	47	20	54	56	0A	20	20	20	20	20	20	20	01	9F

EDID Block 1, Bytes 128-255

	0	1	2	3	4	5	6	7	8	9	A	B	C	D	E	F
0	02	03	36	F1	50	61	90	22	20	05	04	03	02	01	5D	5E
10	5F	66	62	63	64	29	3D	06	C0	15	07	50	09	57	07	6E
20	03	0C	00	10	00	B8	3C	20	00	80	01	02	03	04	E3	0E
30	61	66	E3	06	07	01	01	1D	80	18	71	1C	16	20	58	2C
40	25	00	40	84	63	00	00	9E	66	21	50	0	51	00	1B	30
50	40	70	36	00	40	84	63	00	00	1E	00	00	00	00	00	00
60	00	00	00	00	00	00	00	00	00	00	00	00	00	00	00	00
70	00	00	00	00	00	00	00	00	00	00	00	00	00	00	00	11

#DTS HDMI2 (C/S: 9F,A6)_6G_UHD Deep Color ON
EDID Block 0, Bytes 0-127

	0	1	2	3	4	5	6	7	8	9	A	B	C	D	E	F
0	00	FF	FF	FF	FF	FF	FF	00	1E	6D	01	00	01	01	01	01
10	01	1A	01	03	80	A0	5A	78	0A	EE	91	A3	54	4C	99	26
20	0F	50	54	A1	08	00	31	40	45	40	61	40	71	40	81	80
30	01	01	01	01	01	01	08	E8	00	30	F2	70	5A	80	B0	58
40	8A	00	40	84	63	00	00	1E	02	3A	80	18	71	38	2D	40
50	58	2C	45	00	40	84	63	00	00	1E	00	00	00	FD	00	3A
60	3E	1E	88	3C	00	0A	20	20	20	20	20	20	00	00	00	FC
70	00	4C	47	20	54	56	0A	20	20	20	20	20	20	20	01	9F

	0	1	2	3	4	5	6	7	8	9	A	B	C	D	E	F
0	02	03	3A	F1	50	61	90	22	20	05	04	03	02	01	5D	5E
10	5F	66	62	63	64	29	3D	06	C0	15	07	50	09	57	07	6E
20	03	0C	00	20	00	B8	3C	20	00	80	01	02	03	04	67	D8
30	5D	C4	01	78	80	03	E3	05	C0	00	E3	0F	01	10	E3	06
40	07	01	01	1D	80	18	71	1C	16	20	58	2C	25	00	40	84
50	63	00	00	9E	66	21	50	B0	51	00	1B	30	40	70	36	00
60	40	84	63	00	00	1E	00	00	00	00	00	00	00	00	00	00
70	00	00	00	00	00	00	00	00	00	00	00	00	00	00	00	A6

#DTS HDMI2 (C/S: 9F 01)_3G_UHD Deep Color OFF
EDID Block 0, Bytes 0-127

	0	1	2	3	4	5	6	7	8	9	A	B	C	D	E	F
0	00	FF	FF	FF	FF	FF	FF	00	1E	6D	01	00	01	01	01	01
10	01	1A	01	03	80	A0	5A	78	0A	EE	91	A3	54	4C	99	26
20	0F	50	54	A1	08	00	31	40	45	40	61	40	71	40	81	80
30	01	01	01	01	01	01	08	E8	00	30	F2	70	5A	80	B0	58
40	8A	00	40	84	63	00	00	1E	02	3A	80	18	71	38	2D	40
50	58	2C	45	00	40	84	63	00	00	1E	00	00	00	FD	00	3A
60	3E	1E	88	3C	00	0A	20	20	20	20	20	20	00	00	00	FC
70	00	4C	47	20	54	56	0A	20	20	20	20	20	20	20	01	9F

EDID Block 1, Bytes 128-255

	0	1	2	3	4	5	6	7	8	9	A	B	C	D	E	F
0	02	03	36	F1	50	61	90	22	20	05	04	03	02	01	5D	5E
10	5F	66	62	63	64	29	3D	06	C0	15	07	50	09	57	07	6E
20	03	0C	00	20	00	B8	3C	20	00	80	01	02	03	04	E3	0E
30	61	66	E3	06	07	01	01	1D	80	18	71	1C	16	20	58	2C
40	25	00	40	84	63	00	00	9E	66	21	50	0	51	00	1B	30
50	40	70	36	00	40	84	63	00	00	1E	00	00	00	00	00	00
60	00	00	00	00	00	00	00	00	00	00	00	00	00	00	00	00
70	00	00	00	00	00	00	00	00	00	00	00	00	00	00	00	01

#DTS HDMI3 (C/S: 9F, 96)_6G_UHD Deep Color ON
EDID Block 0, Bytes 0-127

	0	1	2	3	4	5	6	7	8	9	A	B	C	D	E	F
0	00	FF	FF	FF	FF	FF	FF	00	1E	6D	01	00	01	01	01	01
10	01	1A	01	03	80	A0	5A	78	0A	EE	91	A3	54	4C	99	26
20	0F	50	54	A1	08	00	31	40	45	40	61	40	71	40	81	80
30	01	01	01	01	01	01	08	E8	00	30	F2	70	5A	80	B0	58
40	8A	00	40	84	63	00	00	1E	02	3A	80	18	71	38	2D	40
50	58	2C	45	00	40	84	63	00	00	1E	00	00	00	FD	00	3A
60	3E	1E	88	3C	00	0A	20	20	20	20	20	20	20	00	00	FC
70	00	4C	47	20	54	56	0A	20	20	20	20	20	20	20	01	9F

EDID Block 1, Bytes 128-255

	0	1	2	3	4	5	6	7	8	9	A	B	C	D	E	F
0	02	03	3A	F1	50	61	90	22	20	05	04	03	02	01	5D	5E
10	5F	66	62	63	64	29	3D	06	C0	15	07	50	09	57	07	6E
20	03	0C	00	30	00	B8	3C	20	00	80	01	02	03	04	67	D8
30	5D	C4	01	78	80	03	E3	05	C0	00	E3	0F	01	10	E3	06
40	07	01	01	1D	80	18	71	1C	16	20	58	2C	25	00	40	84
50	63	00	00	9E	66	21	50	B0	51	00	1B	30	40	70	36	00
60	40	84	63	00	00	1E	00	00	00	00	00	00	00	00	00	00
70	00	00	00	00	00	00	00	00	00	00	00	00	00	00	00	96

#DTS HDMI3 (C/S: 9F F1)_3G_UHD Deep Color OFF
EDID Block 0, Bytes 0-127

	0	1	2	3	4	5	6	7	8	9	A	B	C	D	E	F
0	00	FF	FF	FF	FF	FF	FF	00	1E	6D	01	00	01	01	01	01
10	01	1A	01	03	80	A0	5A	78	0A	EE	91	A3	54	4C	99	26
20	0F	50	54	A1	08	00	31	40	45	40	61	40	71	40	81	80
30	01	01	01	01	01	01	08	E8	00	30	F2	70	5A	80	B0	58
40	8A	00	40	84	63	00	00	1E	02	3A	80	18	71	38	2D	40
50	58	2C	45	00	40	84	63	00	00	1E	00	00	00	FD	00	3A
60	3E	1E	88	3C	00	0A	20	20	20	20	20	20	20	00	00	FC
70	00	4C	47	20	54	56	0A	20	20	20	20	20	20	20	01	9F

EDID Block 1, Bytes 128-255

	0	1	2	3	4	5	6	7	8	9	A	B	C	D	E	F
0	02	03	36	F1	50	61	90	22	20	05	04	03	02	01	5D	5E
10	5F	66	62	63	64	29	3D	06	C0	15	07	50	09	57	07	6E
20	03	0C	00	30	00	B8	3C	20	00	80	01	02	03	04	E3	0E
30	61	66	E3	06	07	01	01	1D	80	18	71	1C	16	20	58	2C
40	25	00	40	84	63	00	00	9E	66	21	50	0	51	00	1B	30
50	40	70	36	00	40	84	63	00	00	1E	00	00	00	00	00	00
60	00	00	00	00	00	00	00	00	00	00	00	00	00	00	00	00
70	00	00	00	00	00	00	00	00	00	00	00	00	00	00	00	F1

#AC3 HDMI1 (C/S: 9F,BF)_6G_UHD Deep Color ON

	0	1	2	3	4	5	6	7	8	9	A	B	C	D	E	F
0	00	FF	FF	FF	FF	FF	FF	00	1E	6D	01	00	01	01	01	01
10	01	1A	01	03	80	A0	5A	78	0A	EE	91	A3	54	4C	99	26
20	0F	5														

PCM HDMI1 (C/S: 9F,8C)_3G_UHD Deep Color OFF

0	0	1	2	3	4	5	6	7	8	9	A	B	C	D	E	F
0	00	FF	FF	FF	FF	FF	FF	00	1E	6D	01	00	01	01	01	01
10	01	1A	01	03	80	A0	5A	78	0A	EE	91	A3	54	4C	99	26
20	0F	50	54	A1	08	00	31	40	45	40	61	40	71	40	81	80
30	01	01	01	01	01	01	08	E8	00	30	F2	70	5A	80	B0	58
40	8A	00	40	84	63	00	00	1E	02	3A	80	18	71	38	2D	40
50	58	2C	45	00	40	84	63	00	00	1E	00	00	00	FD	00	3A
60	3E	1E	88	3C	00	0A	20	20	20	20	20	20	00	00	00	FC
70	00	4C	47	20	54	56	0A	20	20	20	20	20	20	20	01	9F
0	0	1	2	3	4	5	6	7	8	9	A	B	C	D	E	F
0	02	03	30	F1	50	61	10	22	20	05	04	03	02	01	5D	5E
10	5F	66	62	63	64	23	09	57	07	6E	03	0C	00	10	00	B8
20	3C	20	00	80	01	02	03	04	E3	0E	61	66	E3	06	07	01
30	01	1D	80	18	71	1C	16	20	58	2C	25	00	40	84	63	00
40	00	9E	66	21	50	B0	51	00	1B	30	40	70	36	00	40	84
50	63	00	00	1E	00	00	00	00	00	00	00	00	00	00	00	00
60	00	00	00	00	00	00	00	00	00	00	00	00	00	00	00	00
70	00	00	00	00	00	00	00	00	00	00	00	00	00	00	00	8C

PCM HDMI3 (C/S: 9F,11)_6G_UHD Deep Color ON

0	0	1	2	3	4	5	6	7	8	9	A	B	C	D	E	F
0	00	FF	FF	FF	FF	FF	FF	00	1E	6D	01	00	01	01	01	01
10	01	1A	01	03	80	A0	5A	78	0A	EE	91	A3	54	4C	99	26
20	0F	50	54	A1	08	00	31	40	45	40	61	40	71	40	81	80
30	01	01	01	01	01	01	08	E8	00	30	F2	70	5A	80	B0	58
40	8A	00	40	84	63	00	00	1E	02	3A	80	18	71	38	2D	40
50	58	2C	45	00	40	84	63	00	00	1E	00	00	00	FD	00	3A
60	3E	1E	88	3C	00	0A	20	20	20	20	20	20	20	20	00	FC
70	00	4C	47	20	54	56	0A	20	20	20	20	20	20	20	01	9F
0	0	1	2	3	4	5	6	7	8	9	A	B	C	D	E	F
0	02	03	34	F1	50	61	10	22	20	05	04	03	02	01	5D	5E
10	5F	66	62	63	64	23	09	57	07	6E	03	0C	00	30	00	B8
20	3C	20	00	80	01	02	03	04	67	D8	5D	C4	01	78	80	03
30	E3	05	C0	00	E3	0F	01	10	E3	06	07	01	01	1D	80	18
40	71	1C	16	20	58	2C	25	00	40	84	63	00	00	9E	66	21
50	50	B0	51	00	1B	30	40	70	36	00	40	84	63	00	00	1E
60	00	00	00	00	00	00	00	00	00	00	00	00	00	00	00	00
70	00	00	00	00	00	00	00	00	00	00	00	00	00	00	00	11

PCM HDMI1 (C/S: 9F,21)_6G_UHD Deep Color ON

0	0	1	2	3	4	5	6	7	8	9	A	B	C	D	E	F
0	00	FF	FF	FF	FF	FF	FF	00	1E	6D	01	00	01	01	01	01
10	01	1A	01	03	80	A0	5A	78	0A	EE	91	A3	54	4C	99	26
20	0F	50	54	A1	08	00	31	40	45	40	61	40	71	40	81	80
30	01	01	01	01	01	01	08	E8	00	30	F2	70	5A	80	B0	58
40	8A	00	40	84	63	00	00	1E	02	3A	80	18	71	38	2D	40
50	58	2C	45	00	40	84	63	00	00	1E	00	00	00	FD	00	3A
60	3E	1E	88	3C	00	0A	20	20	20	20	20	20	00	00	00	FC
70	00	4C	47	20	54	56	0A	20	20	20	20	20	20	20	01	9F
0	0	1	2	3	4	5	6	7	8	9	A	B	C	D	E	F
0	02	03	34	F1	50	61	10	22	20	05	04	03	02	01	5D	5E
10	5F	66	62	63	64	23	09	57	07	6E	03	0C	00	20	00	B8
20	3C	20	00	80	01	02	03	04	67	D8	5D	C4	01	78	80	03
30	E3	05	C0	00	E3	0F	01	10	E3	06	07	01	01	1D	80	18
40	71	1C	16	20	58	2C	25	00	40	84	63	00	00	9E	66	21
50	50	B0	51	00	1B	30	40	70	36	00	40	84	63	00	00	1E
60	00	00	00	00	00	00	00	00	00	00	00	00	00	00	00	00
70	00	00	00	00	00	00	00	00	00	00	00	00	00	00	00	21

PCM HDMI3 (C/S: 9F,6C)_3G_UHD Deep Color OFF

0	0	1	2	3	4	5	6	7	8	9	A	B	C	D	E	F
0	FF	FF	FF	FF	FF	FF	FF	00	1E	6D	01	00	01	01	01	01
10	1A	01	03	80	A0	5A	78	0A	EE	91	A3	54	4C	99	26	26
20	50	54	A1	08	00	31	40	45	40	61	40	71	40	81	80	80
30	01	01	01	01	01	01	08	E8	00	30	F2	70	5A	80	B0	58
40	00	40	84	63	00	00	1E	02	3A	80	18	71	38	2D	40	40
50	2C	45	00	40	84	63	00	00	1E	00	00	00	00	FD	00	3A
60	1E	88	3C	00	0A	20	20	20	20	20	20	20	00	00	00	FC
70	4C	47	20	54	56	0A	20	20	20	20	20	20	20	20	01	9F
0	0	1	2	3	4	5	6	7	8	9	A	B	C	D	E	F
0	02	03	30	F1	50	61	10	22	20	05	04	03	02	01	5D	5E
10	5F	66	62	63	64	23	09	57	07	6E	03	0C	00	30	00	B8
20	3C	30	00	80	01	02	03	04	E3	0E	61	66	E3	06	07	01
30	01	1D	80	18	71	1C	16	20	58	2C	25	00	40	84	63	00
40	00	9E	66	21	50	B0	51	00	1B	30	40	70	36	00	40	84
50	63	00	00	1E	00	00	00	00	00	00	00	00	00	00	00	00
60	00	00	00	00	00	00	00	00	00	00	00	00	00	00	00	00
70	00	00	00	00	00	00	00	00	00	00	00	00	00	00	00	6C

PCM HDMI2 (C/S: 9F,7C)_3G_UHD Deep Color OFF

0	0	1	2	3	4	5	6	7	8	9	A	B	C	D	E	F
0	00	FF	FF	FF	FF	FF	FF	00	1E	6D	01	00	01	01	01	01
10	01	1A	01	03	80	A0	5A	78	0A	EE	91	A3	54	4C	99	26
20	0F	50	54	A1	08	00	31	40	45	40	61	40	71	40	81	80
30	01	01	01	01	01	01	08	E8	00	30	F2	70	5A	80	B0	58
40	8A	00	40	84	63	00	00	1E	02	3A	80	18	71	38	2D	40
50	58	2C	45	00	40	84	63	00	00	1E	00	00	00	FD	00	3A
60	3E	1E	88	3C	00	0A	20	20	20	20	20	20	00	00	00	FC
70	00	4C	47	20	54	56	0A	20	20	20	20	20	20	20	01	9F
0	0	1	2	3	4	5	6	7	8	9	A	B	C	D	E	F
0	02	03	30	F1	50	61	10	22	20	05	04	03	02	01	5D	5E
10	5F	66	62	63	64	23	09	57	07	6E	03	0C	00	20	00	B8
20	3C	20	00	80	01	02	03	04	E3	0E	61	66	E3	06	07	01
30	01	1D	80	18	71	1C	16	20	58	2C	25	00	40	84	63	00
40	00	9E	66	21	50	B0	51	00	1B	30	40	70	36	00	40	84
50	63	00	00	1E	00	00	00	00	00	00	00	00	00	00	00	00
60	00	00	00	00	00	00	00	00	00	00	00	00	00	00	00	00
70	00	00	00	00	00	00	00	00	00	00	00	00	00	00	00	7C

* Checksum (HDMI 1/2/3/4)

2D ONLY	PCM	
	3G	6G
HDMI1	0x9F, 0x8C	0x9F, 0x31
HDMI2	0x9F, 0x7C	0x9F, 0x21
HDMI3	0x9F, 0x6C	0x9F, 0x11

2D ONLY	AC3	
	3G	6G
HDMI1	0x9F, 0x1A	0x9F, 0xBF
HDMI2	0x9F, 0x0A	0x9F, 0xAF
HDMI3	0x9F, 0xFA	0x9F, 0x9F

2D ONLY	DTS	
	3G	6G
HDMI1	0x9F, 0x11	0x9F, 0xB6
HDMI2	0x9F, 0x01	0x9F, 0xA6
HDMI3	0x9F, 0xF1	0x9F, 0x96

5.3. Camera Port Inspection

- (1) Objective : To check how it connects between Camera and PCBA normally, and their Function
- (2) Test Method : This Inspection is available only Power-Only Status.
 - 1) Push Camera Up
 - 2) Camera's Preview picture appears on TV Set
 - 3) Push Camera Down

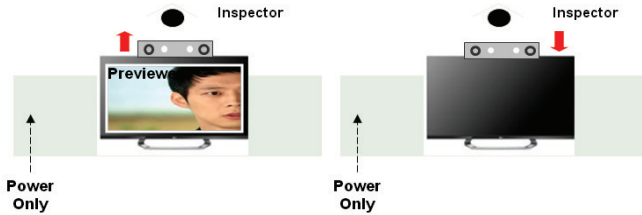

(3) RS-232C Command

RS-232C COMMAND			Explanation
CMD	DATA	ID	
Ai	00	23	Camera Function Start.
Ai	00	24	Camera Function End.

5.4. V-COM Adjust

(ONLY FOR EPI model, 43/49/55UH6600, 43/49/55UH6500)

5.4.1. Overview

- V-COM adj. Objective & How-it-works
- Objective: To reduce each Panel's V-COM voltage deviation
- How-it-works: When V-COM gain in the adjust-OSD of each SET is at default value, each SET can have flicker by each Panel's V-COM voltage deviation. In order to prevent flicker of each SET, find the desired each Panel's V-COM voltage value.
- Adj. condition: normal temperature
 - 1) Surrounding Temperature: 25 °C ± 5 °C
 - 2) Warm-up time: About 5 Min
 - 3) Surrounding Humidity: 20% ~ 80%

5.4.2. Equipment

- (1) Color Analyzer: CA-310 (LED Module : CH 14) or CM-H505
- (2) Adj. Computer (During auto adj., RS-232C protocol is needed)
- (3) Adjust Remocon
- (4) Signal : internal flicker Pattern in SET
 - Color Analyzer Matrix should be calibrated using CS-100

5.4.3. Equipment connection MAP

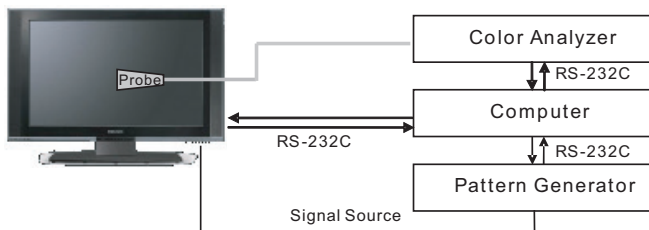

* If TV internal pattern is used, not needed

5.4.4. Adj. Command (Protocol)

<Command Format>
CMD ID DATA CR RF

- CMD: Command
- ID : Command
- Data : Command
- (Ex) [Send: va 00 00\r\n]

(1) RS-232C Command used during auto-adj.

RS-232C COMMAND			Explanation
CMD	DATA	ID	
va	00	00	V-com pattern
vb	00	00 ~ FE	V-com adj.(internal Flicker pattern)
wb	00	FF	V-com adj. completed

5.4.5. Adjustment method

- (1) Set TV in POWER-ONLY mode using POWER ONLY key
 - (2) Zero calibrate probe then place it on the center of the Display
 - (3) Connect Cable (RS-232C to USB)
 - (4) Select Model in "V-com adj. Program" and begin "V-com adj."
 - (5) When V-com adj. is complete (OK)
 - (6) Remove probe and RS-232C to USB cable to complete adj.
- V-com Adj. must begin as start command "va 00 00" , and finish as end command "wb 00 ff"

▪ V-com adjust data

	43" inch		49" inch		55" inch		65" inch	
	hex	dec	hex	dec	hex	dec	hex	dec
Max	B4	180	8B	139	85	133	AB	171
Default	96	150	6D	109	68	104	8D	141
Min	78	120	4F	79	49	73	6F	111

5.4.5.1 Manual adj. method
TBD

5.5. White Balance Adjustment

5.5.1. Overview

5.5.1.1. W/B adj. Objective & How-it-works

- (1) Objective: To reduce each Panel's W/B deviation
- (2) How-it-works: When R/G/B gain in the OSD is at 192, it means the panel is at its Full Dynamic Range. In order to prevent saturation of Full Dynamic range and data, one of R/G/B is fixed at 192, and the other two is lowered to find the desired value.
- (3) Adj. condition: normal temperature
 - Surrounding Temperature: 25±5 °C
 - Warm-up time: About 5 Min
 - Surrounding Humidity: 20% ~ 80%

5.5.2. Equipment

- (1) Color Analyzer: CA-210 (LED Module : CH 14)
 - (2) Adj. Computer (During auto adj., RS-232C protocol is needed)
 - (3) Adjust Remocon
 - (4) Video Signal Generator MSPG-925F 720p/204-Gray (Model: 217, Pattern: 49)
- ※ Color Analyzer Matrix should be calibrated using CS-1000

5.5.3. Equipment connection MAP

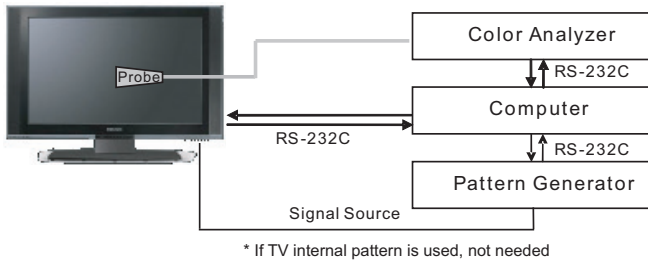

5.5.4. Adj. Command (Protocol)

<Command Format>

START 6E A 50 A LEN A 03 A CMD A 00 A VAL A CS A STOP

- LEN: Number of Data Byte to be sent
 - CMD : Command
 - VAL : FOS Data value
 - CS : Checksum of sent data
 - A : Acknowledge
- (Ex) [Send: JA_00_DD] / [Ack: A_00_okDDX]

(1) RS-232C Command used during auto-adj.

RS-232C COMMAND			Explanation
CMD	DATA	ID	
wb	00	00	Begin White Balance adj.
wb	00	10	Gain adj.(internal white pattern)
wb	00	1f	Gain adj. completed
wb	00	20	Offset adj.(internal white pattern)
wb	00	2f	Offset adj. completed
wb	00	ff	End White Balance adj. (internal pattern disappears)

(Ex) wb 00 00 -> Begin white balance auto-adj.

wb 00 10 -> Gain adj.

ja 00 ff -> Adj. data

jb 00 c0

...

...

wb 00 1f -> Gain adj. complete

* (wb 00 20(start), wb 00 2f(endc)) -> Off-set adj.

wb 00 ff -> End white balance auto adj.

(2) Adjustment Map

Applied Model : ALL MODELS

	Adj. item	Command (lower caseASCII)		Data Range (Hex.)		Default (Decimal)
		CMD1	CMD2	MIN	MAX	
Cool	R Gain	j	g	00	C0	TBD
	G Gain	j	h	00	C0	TBD
	B Gain	j	i	00	C0	TBD
	R Cut					TBD
	G Cut					TBD
	B Cut					TBD
Medium	R Gain	j	a	00	C0	TBD
	G Gain	j	b	00	C0	TBD
	B Gain	j	c	00	C0	TBD
	R Cut					TBD
	G Cut					TBD
	B Cut					TBD
Warm	R Gain	j	d	00	C0	TBD
	G Gain	j	e	00	C0	TBD
	B Gain	j	f	00	C0	TBD
	R Cut					TBD
	G Cut					TBD

5.5.5. Adjustment method

5.5.5.1. Auto WB calibration

- (1) Set TV in adj. mode using POWER ONNY key
- (2) Zero calibrate probe then place it on the center of the Display
- (3) Connect Cable (RS-232C to USB)
- (4) Select mode in adj. Program and begin adj.
- (5) When adj. is complete (OK Sign), check adj. status pre mode(Warm, Medium, Cool)
- (6) Remove probe and RS-232C to USB cable to complete adj.
 - W/B Adj. must begin as start command "wb 00 00" , and finish as end command "wb 00 ff", and Adj. offset if need

5.5.5.2. Manual adj. method

- (1) Set TV in Adj. mode using POWER ON
- (2) Zero Calibrate the probe of Color Analyzer, then place it on the center of LCD module within 10cm of the surface..
- (3) Press ADJ key -> EZ adjust using adj. R/C -> 7. White-Balance then press the cursor to the right (KEY▶).
(When KEY(▶) is pressed 216 Gray internal pattern will be displayed)
- (4) One of R Gain / G Gain / B Gain should be fixed at 192, and the rest will be lowered to meet the desired value.
- (5) Adj. is performed in COOL, MEDIUM, WARM 3 modes of color temperature.

** R-fix adjustment

Adjust modes (Cool), Fix the R gain to 210 (default data) and change the others (G/B Gain).

- Adjust the R gain more than 210 (If G gain or B gain is less than 0 , R gain can adjust more than 210) and change the others (G/B Gain).

- Adjust two modes (Medium / Warm), Fix the one of R/G/B gain to 192 (default data) and decrease the others.

▪ If internal pattern is not available, use RF input. In EZ Adj. menu 7.White Balance, you can select one of 2 Test-pattern: ON, OFF. Default is inner(ON). By selecting OFF, you can adjust using RF signal in 216 Gray pattern.

▪ Adj. condition and cautionary items

(1) Lighting condition in surrounding area

Surrounding lighting should be lower 10 lux. Try to isolate adj. area into dark surrounding.

(2) Probe location

- LCD : Color Analyzer (CA-210) probe should be within 10cm and perpendicular of the module surface (80°~ 100°)

(3) Aging time

- After Aging Start, Keep the Power ON status during 5 Minutes.

- In case of LCD, Back-light on should be checked using no signal or Full-white pattern.

5.5.6. Reference (White Balance Adj. coordinate and color temperature)

- Luminance: 206 Gray
- Standard color coordinate and temperature using CS-1000 (over 26 inch)

Mode	Coordinate		Temp	Δuv
	X	Y		
Cool	0.271	0.270	13,000K	0.0000
Medium	0.283	0.289	9,300K	0.0000
Warm	0.313	0.329	6,500K	0.0000

- Standard color coordinate and temperature using CA-210 (CH 14)

Mode	Coordinate		Temp	Δuv
	X	Y		
Cool	0.271±0.002	0.270±0.002	13000K	0.0000
Medium	0.286±0.002	0.289±0.002	9300K	0.0000
Warm	0.313±0.002	0.329±0.002	6500K	0.0000

5.5.7. EDGE & IOL LED White balance table

- Edge & ALEF LED module change color coordinate because of aging time
- apply under the color coordinate table, for compensated aging time

▪ Luminance: 204 Gray, 80IRE

** Except Gumi winter season(Jan~Feb) and except for winter season (Mar ~ Dec) & Global are same as the table below

- Standard color coordinate and temperature using CA-210(CH-14) – by aging time

	Aging time (Min)	Cool		Medium		Warm	
		X	Y	X	Y	X	Y
		271	270	286	289	313	329
1	0-2	282	289	297	308	324	348
2	3-5	281	287	296	306	323	346
3	6-9	279	284	294	303	321	343
4	10-19	277	280	292	299	319	339
5	20-35	275	277	290	296	317	336
6	36-49	274	274	289	293	316	333
7	50-79	273	272	288	291	315	331
8	80-119	272	271	287	290	314	330
9	Over 120	271	270	286	289	313	329

* Use only AUO, INX, Sharp, CSOT, BOE
(Cool temp Spec is 13000K)

	cool		med		warm	
	x	y	x	y	x	y
spec	271	270	286	289	313	329
target	278	280	293	299	320	339

5.6. Local Dimming Function Check

(Step 1) Turn on TV

(Step 2) At the Local Dimming mode, module Edge Backlight moving right to left

Back light of IOP module moving

(Step 3) confirm the Local Dimming mode

(Step 4) Press "exit" Key

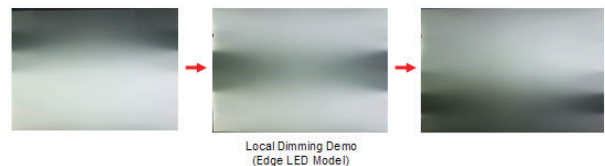

5.7. Magic Motion Remocon test

- Equipment : RF Remocon for test, IR-KEY-Code Remocon for test
- You must confirm the battery power of RF-Remocon before test
(recommend that change the battery per every lot)
- Sequence (test)
 - a) if you select the 'start key(OK)' on the controller, you can pairing with the TV SET.
 - b) You can check the cursor on the TV Screen, when select the 'OK Key' on the controller
 - c) You must remove the pairing with the TV Set by select 'Mute + OK Key' on the controller

5.8. 3D function test

(Pattern Generator MSHG-600, MSPG-6100 [SUPPORT HDMI1.4])
 * HDMI mode NO. 872 , pattern No.83

- (1) Please input 3D test pattern like below (HDMI mode NO. 872 , pattern No.83)



Fig.1
 <HDMI Mode 872번, Pattern No. 83>

- (2) When 3D OSD appear automatically , then select green button



Fig.3
 <OK Key>

- (3) Don't wear a 3D Glasses, Check the picture like below



Fig.2

5.9 HDMI ARC Function Inspection

5.9.1. Test equipment

- Optic Receiver Speaker
- MSHG-600 (SW: 1220 ↑)
- HDMI Cable (for 1.4 version)

5.9.2. Test method

- (1) Insert the HDMI Cable to the HDMI ARC port from the master equipment (HDMI2)
- (2) Check the sound from the TV Set



- (3) Check the Sound from the Speaker or using AV & Optic TEST program (It's connected to MSHG-600)

5.10. EYE-Q Green Function Inspection

- (Step 1) Turn on the TV.
- (Step 2) Press 'EYE' button' on the adjustment remote-controller.
- (Step 3) Cover 'Eye Q sensor' on the front of set with your hands, hold it for 6 seconds.
- (Step 4) Check "the Sensor Data" on the screen, make certain that Data is below 10. If Data isn't below 10 in 6 seconds, Eye Q sensor would be bad. You should change Eye Q sensor.
- (Step 5) Uncover your hands from Eye Q sensor, hold it for 6 seconds.
- (Step 6) Check "Back Light(xxx)" on the screen, check data increase . You should change Eye Q sensor

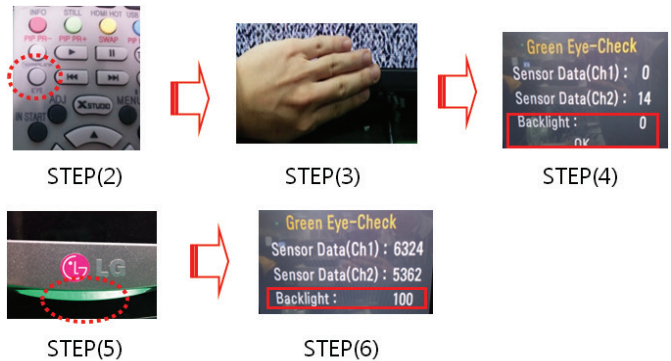

5.11. Ship-out mode check (In-stop)

- After final inspection, press In-Stop key of the Adj. R/C and check that the unit goes to Stand-by mode.

6. GND and Internal Pressure check

6.1. Method

- (1) GND & Internal Pressure auto-check preparation
 - Check that Power Cord is fully inserted to the SET. (If loose, re-insert)
- (2) Perform GND & Internal Pressure auto-check
 - Unit fully inserted Power cord, Antenna cable and A/V arrive to the auto-check process.
 - Connect D-terminal to AV JACK TESTER
 - Auto CONTROLLER(GWS103-4) ON
 - Perform GND TEST
 - If NG, Buzzer will sound to inform the operator.
 - If OK, changeover to I/P check automatically. (Remove CORD, A/V form AV JACK BOX)
 - Perform I/P test
 - If NG, Buzzer will sound to inform the operator.
 - If OK, Good lamp will lit up and the stopper will allow the pallet to move on to next process.

6.2. Checkpoint

- (1) Test voltage
 - GND: 1.5KV/min at 100mA
 - SIGNAL: 3KV/min at 100mA
- (2) TEST time: 1 second
- (3) TEST POINT
 - GND Test = POWER CORD GND and SIGNAL CABLE GND.
 - Hi-pot Test = POWER CORD GND and LIVE & NEUTRAL.
- (4) LEAKAGE CURRENT: At 0.5mArms

7. AUDIO output check

No	Item	Min	Typ	Max	Unit	Remark
1	Audio practical max Output, L/R (Distortion=10% max Output)		10.0 8.10	12.0 10.8	W Vrms	EQ Off AVL Off Clear Voice Off
2	Speaker (8Ω Impedance)		10	12	W	EQ On AVL On Clear Voice On

*Measurement condition:

- (1) RF input: Mono, 1KHz sine wave signal, 100% Modulation
- (2) CVBS, Component: 1KHz sine wave signal (0.4Vrms)
- (3) RGB PC: 1KHz sine wave signal (0.7Vrms)

8. USB S/W Download

(optional, Service only)

- (1) Put the USB Stick to the USB socket
- (2) Automatically detecting update file in USB Stick
 - If your downloaded program version in USB Stick is lower than that of TV set, it didn't work. Otherwise USB data is automatically detected.
- (3) Show the message "Copying files from memory"



- (4) Updating is starting



- (5) Updating Completed, The TV will restart automatically

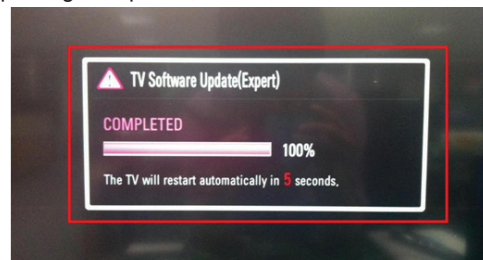

- (6) If your TV is turned on, check your updated version and Tool option.

* If downloading version is more high than your TV have, TV can lost all channel data. In this case, you have to channel recover. If all channel data is cleared, you didn't have a DTV/ATV test on production line.

* After downloading, TOOL OPTION setting is needed again.

- (1) Push "IN-START" key in service remote controller.
- (2) Select "Tool Option 1" and Push "OK" button.
- (3) Punch in the number. (Each model has their number.)

Block Diagram

1. K2Lp Circuit Block Diagram

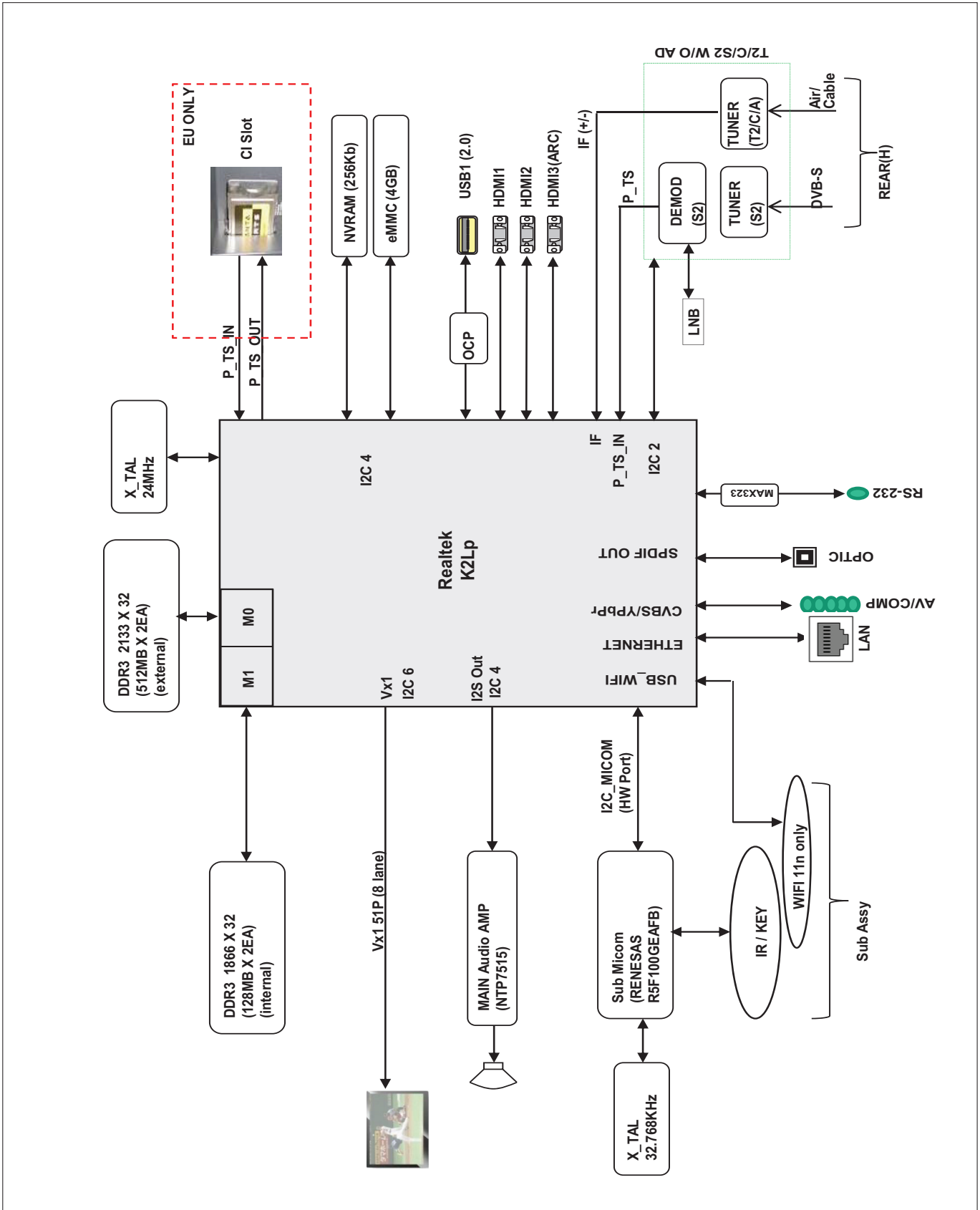

2. K2Lp I2C Block Diagram

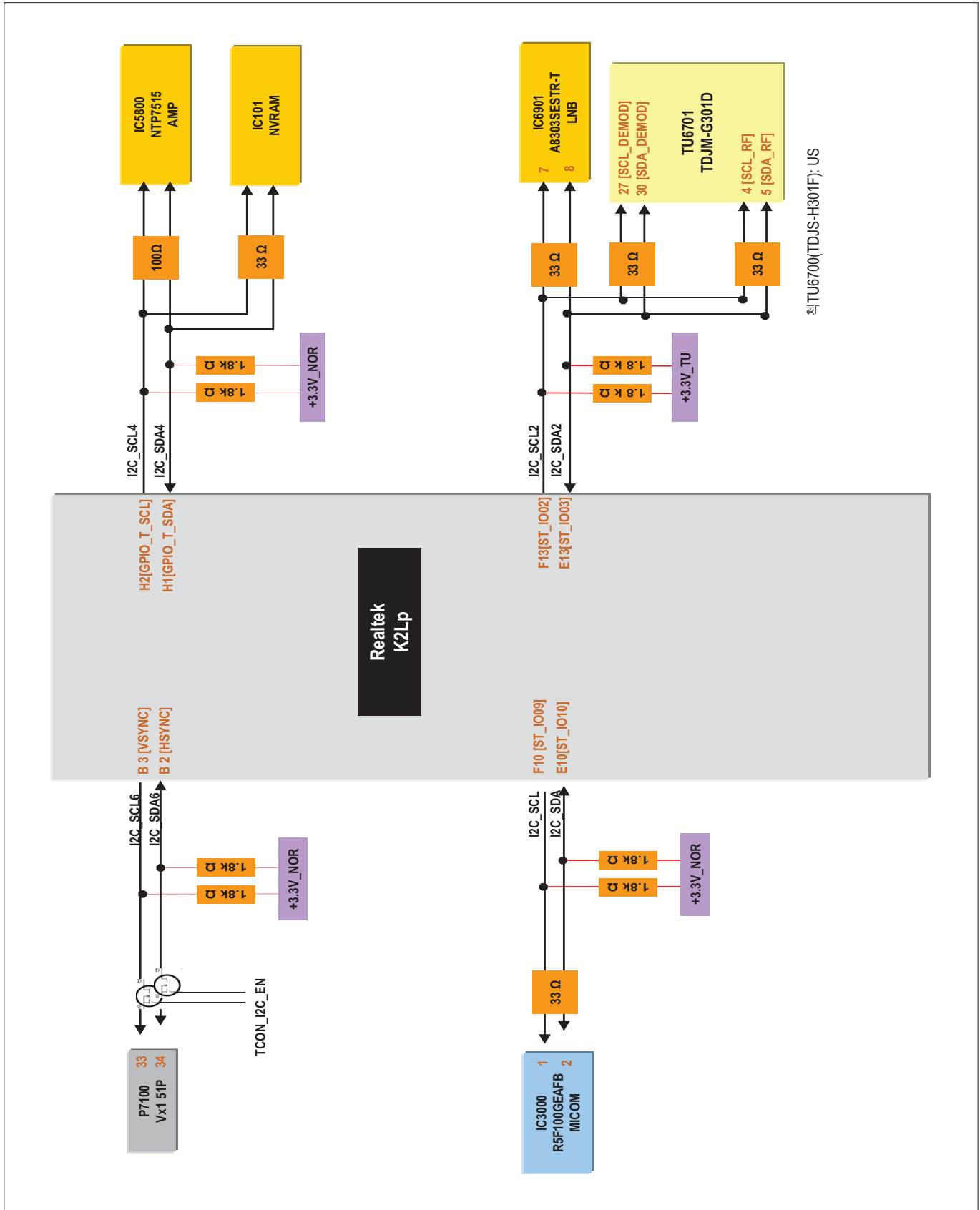

3. K2Lp Power Block

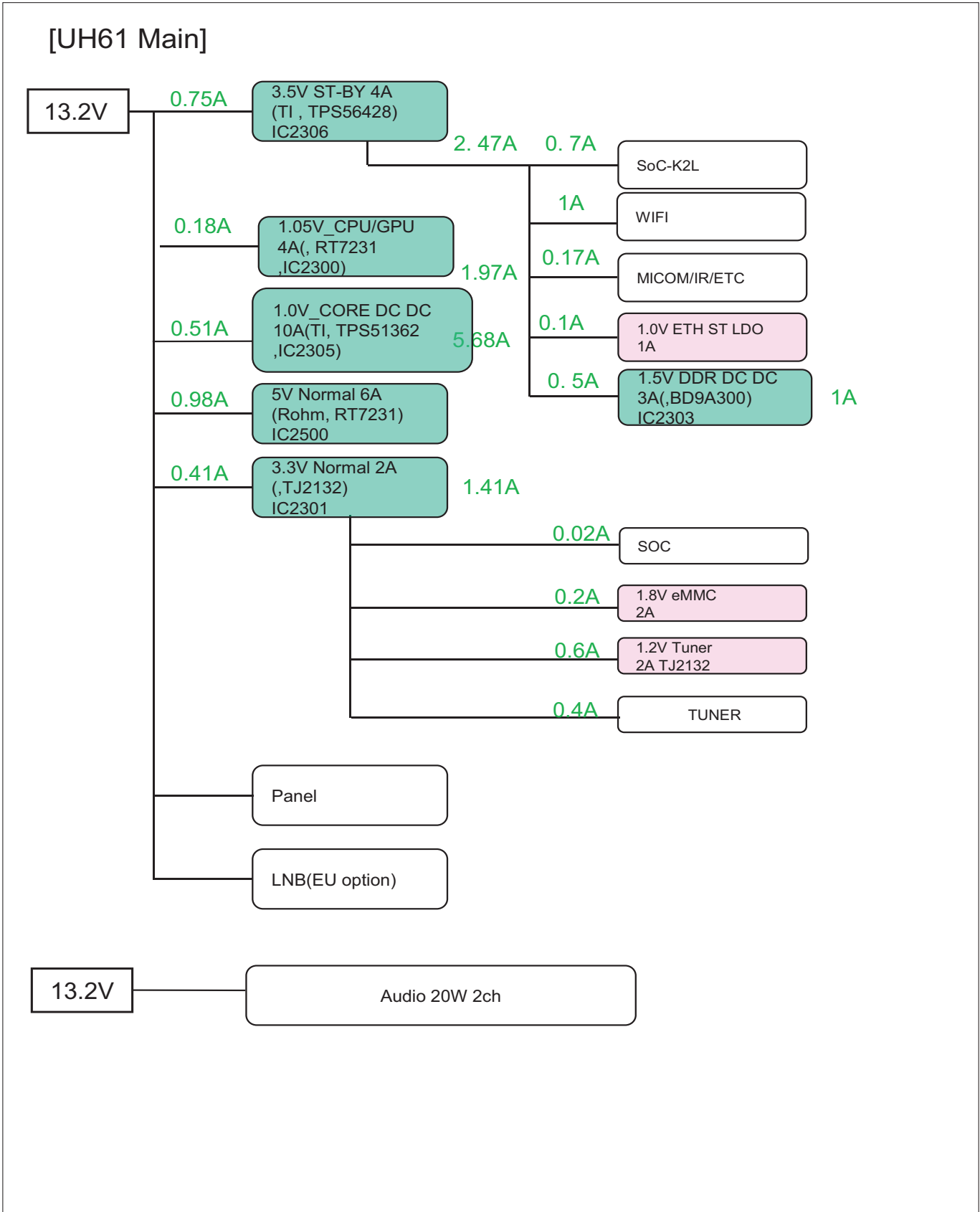

4. Tuner/CI Block Diagram

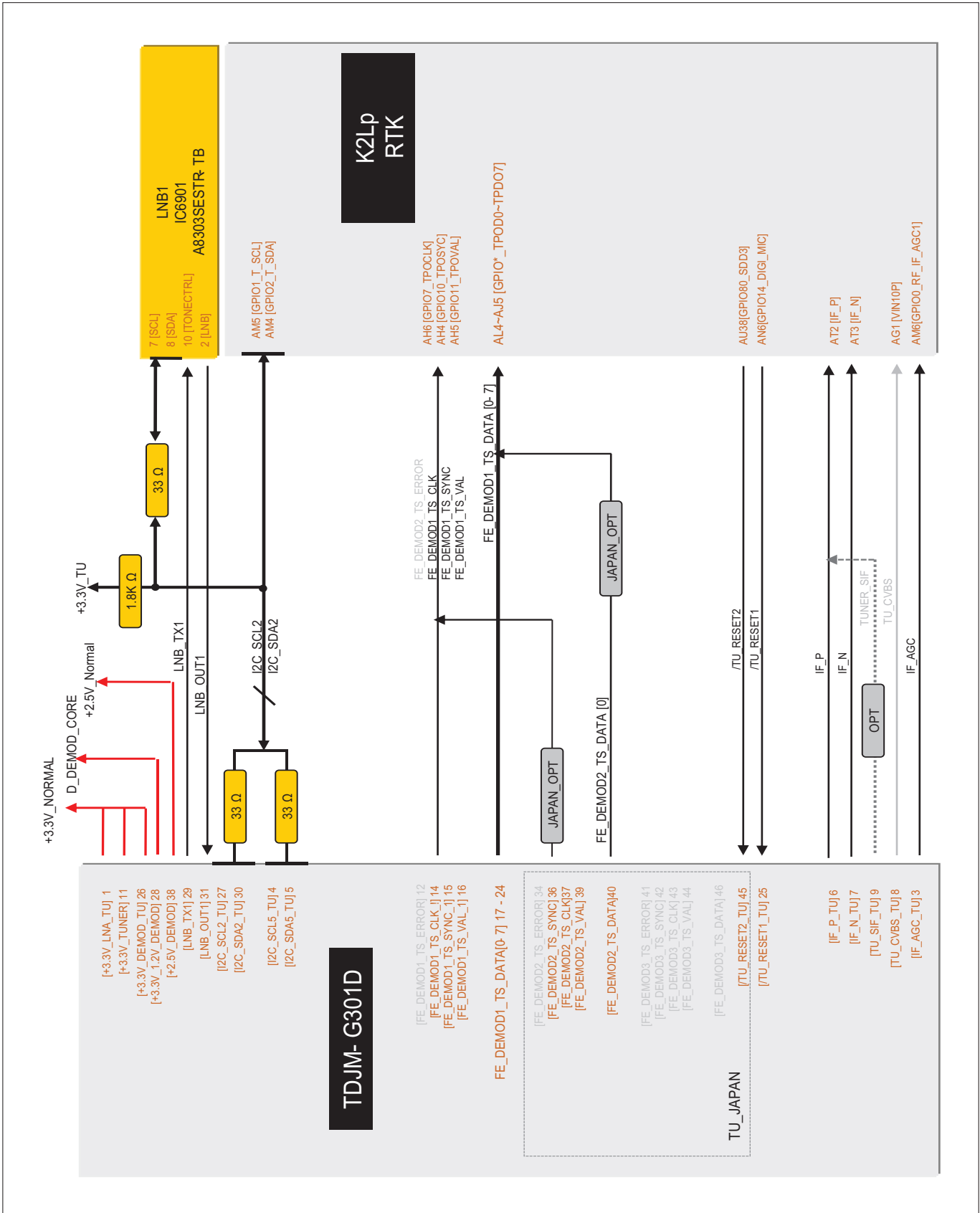

5. Video/Audio In Block Diagram

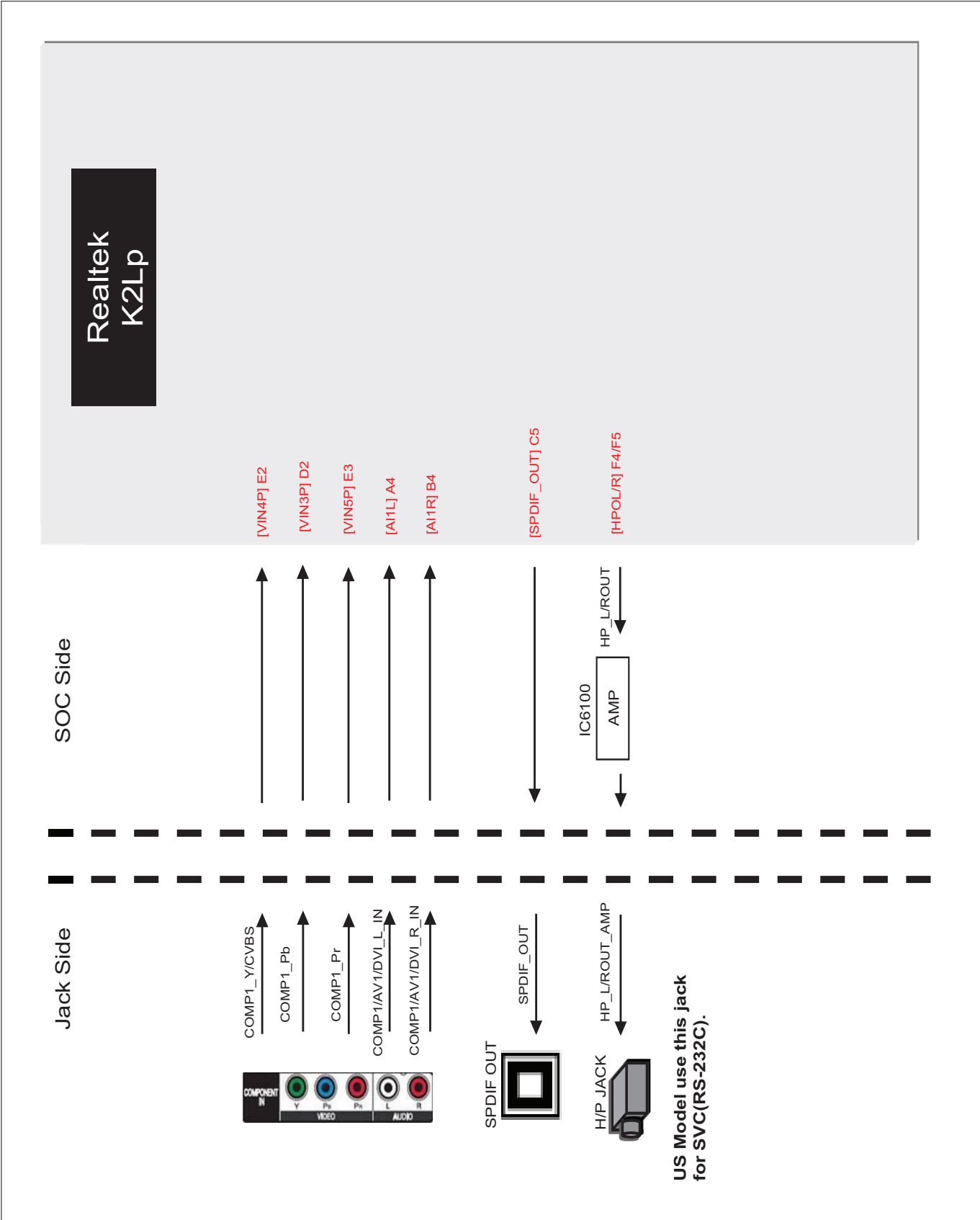

6. Audio Out Block Diagram

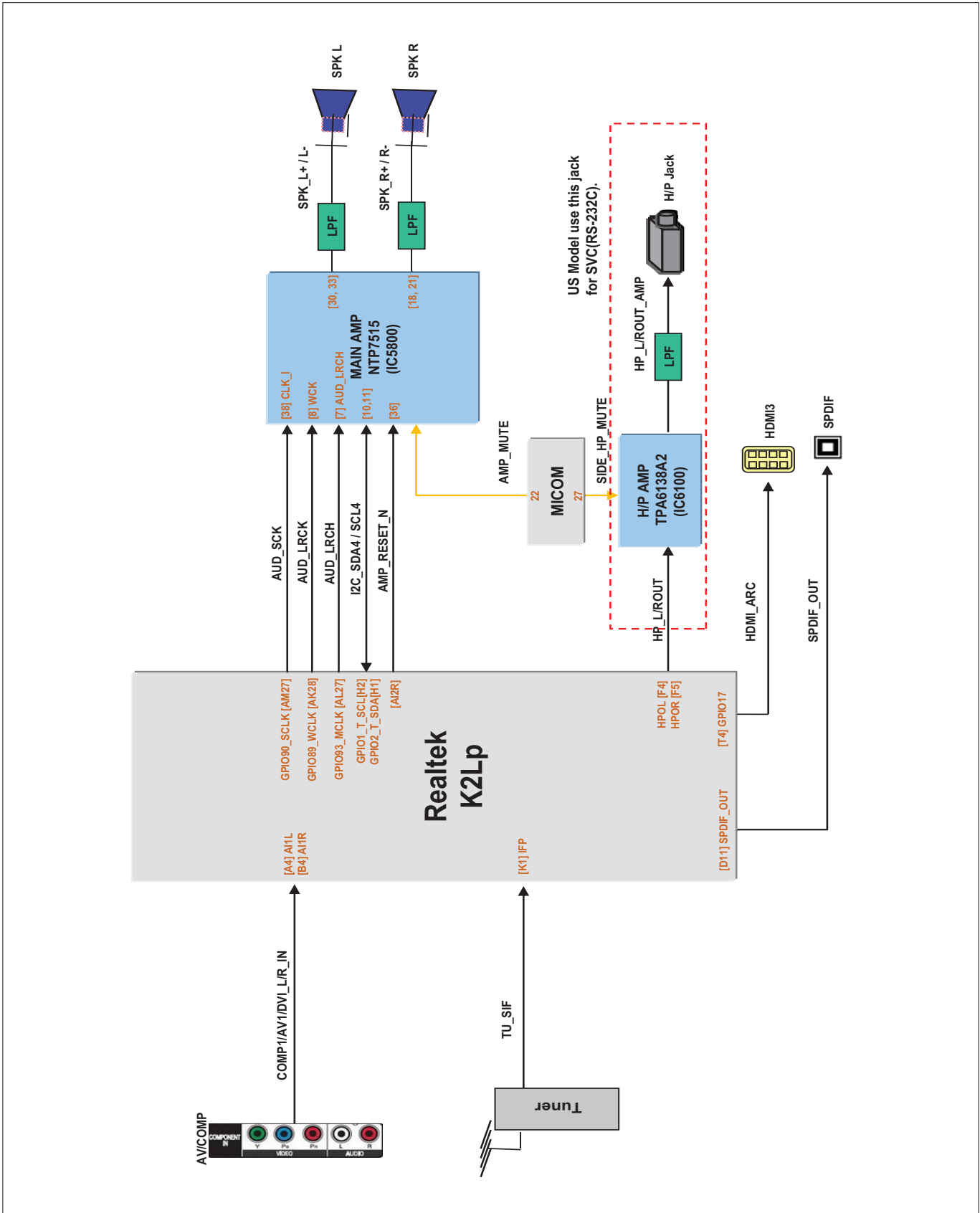

7. HDMI

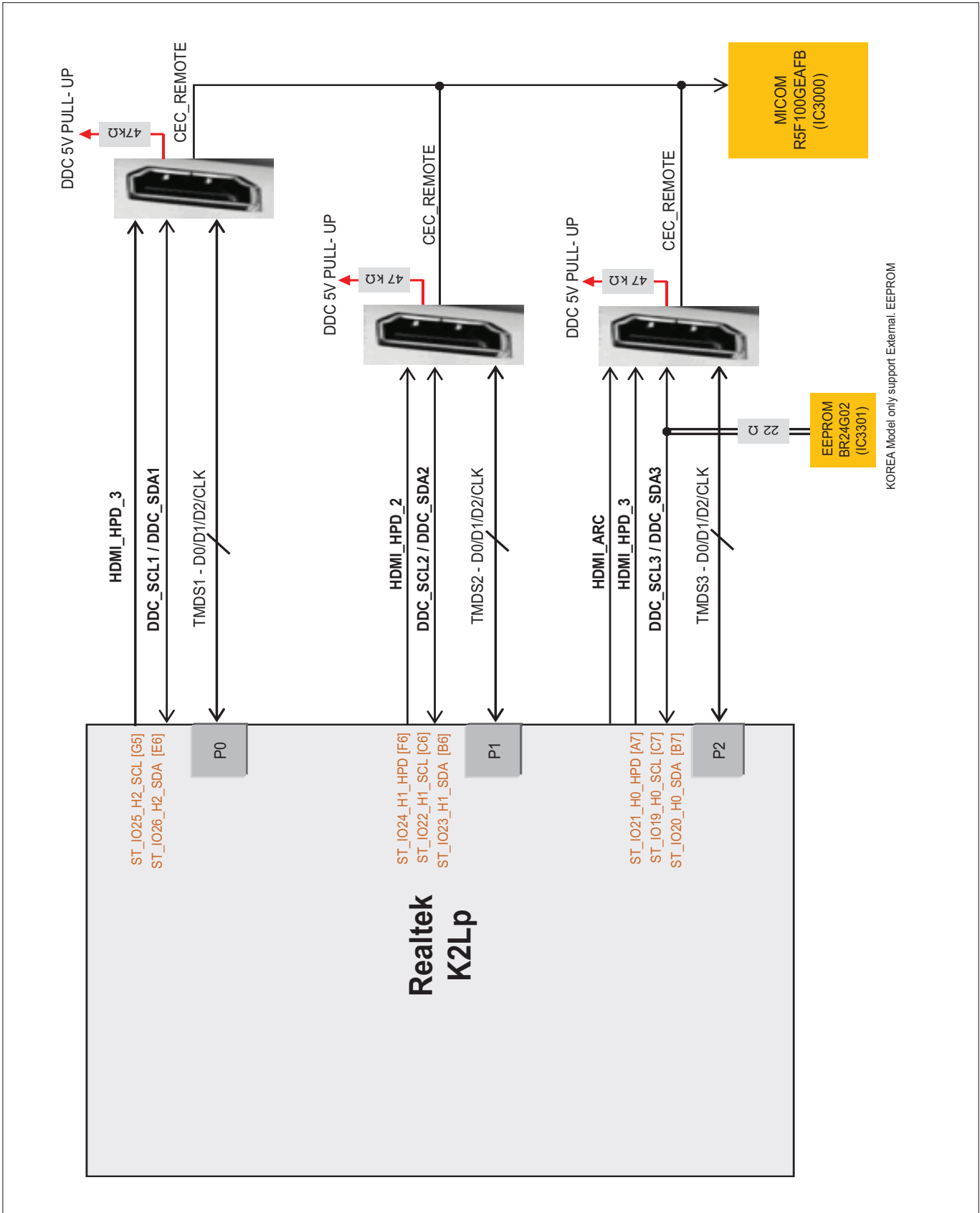

8. USB / WIFI / UART

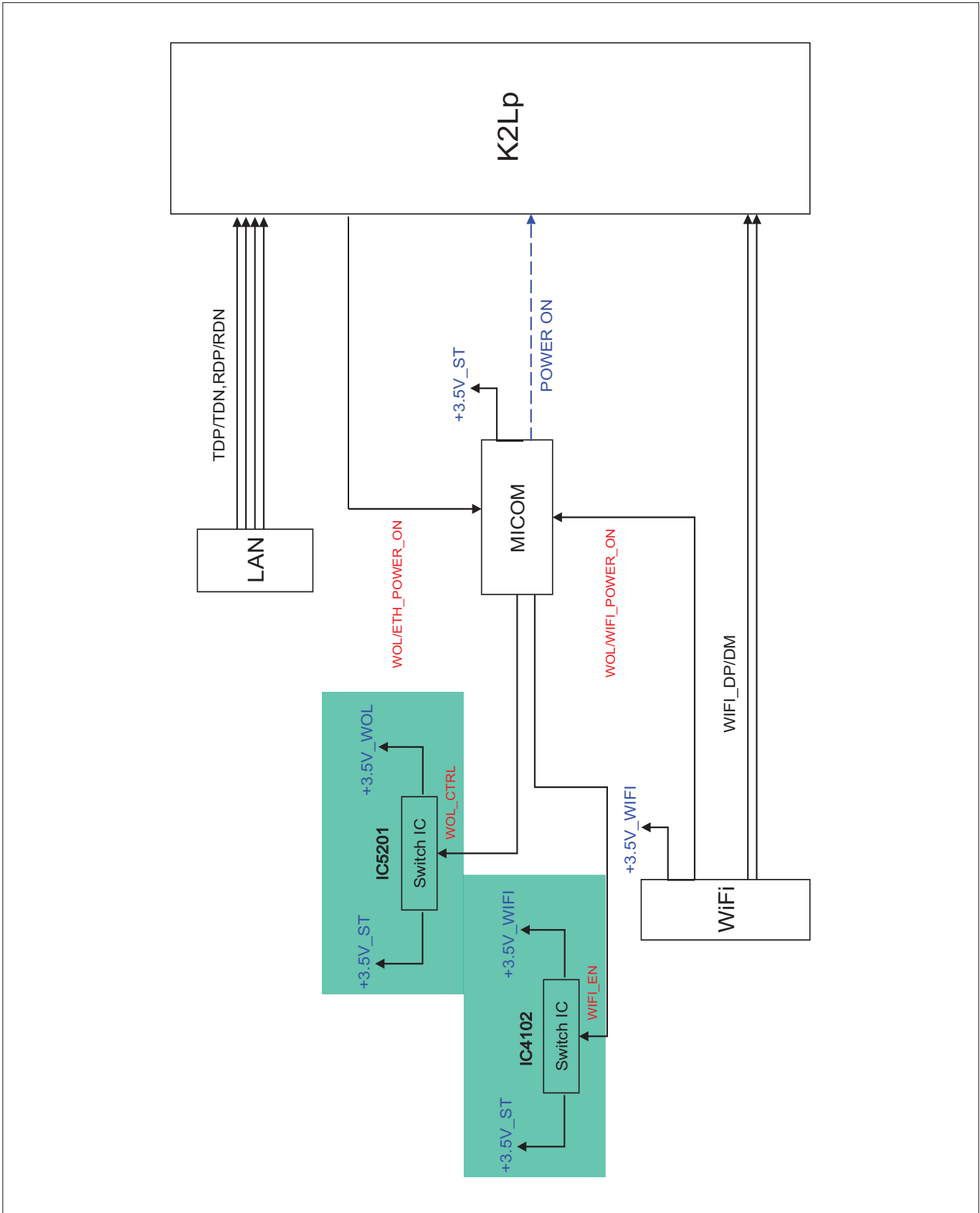

EXPLODED VIEW

IMPORTANT SAFETY NOTICE

Many electrical and mechanical parts in this chassis have special safety-related characteristics. These parts are identified by Δ in the Schematic Diagram and EXPLODED VIEW. It is essential that these special safety parts should be replaced with the same components as recommended in this manual to prevent Shock, Fire, or other Hazards. Do not modify the original design without permission of manufacturer.

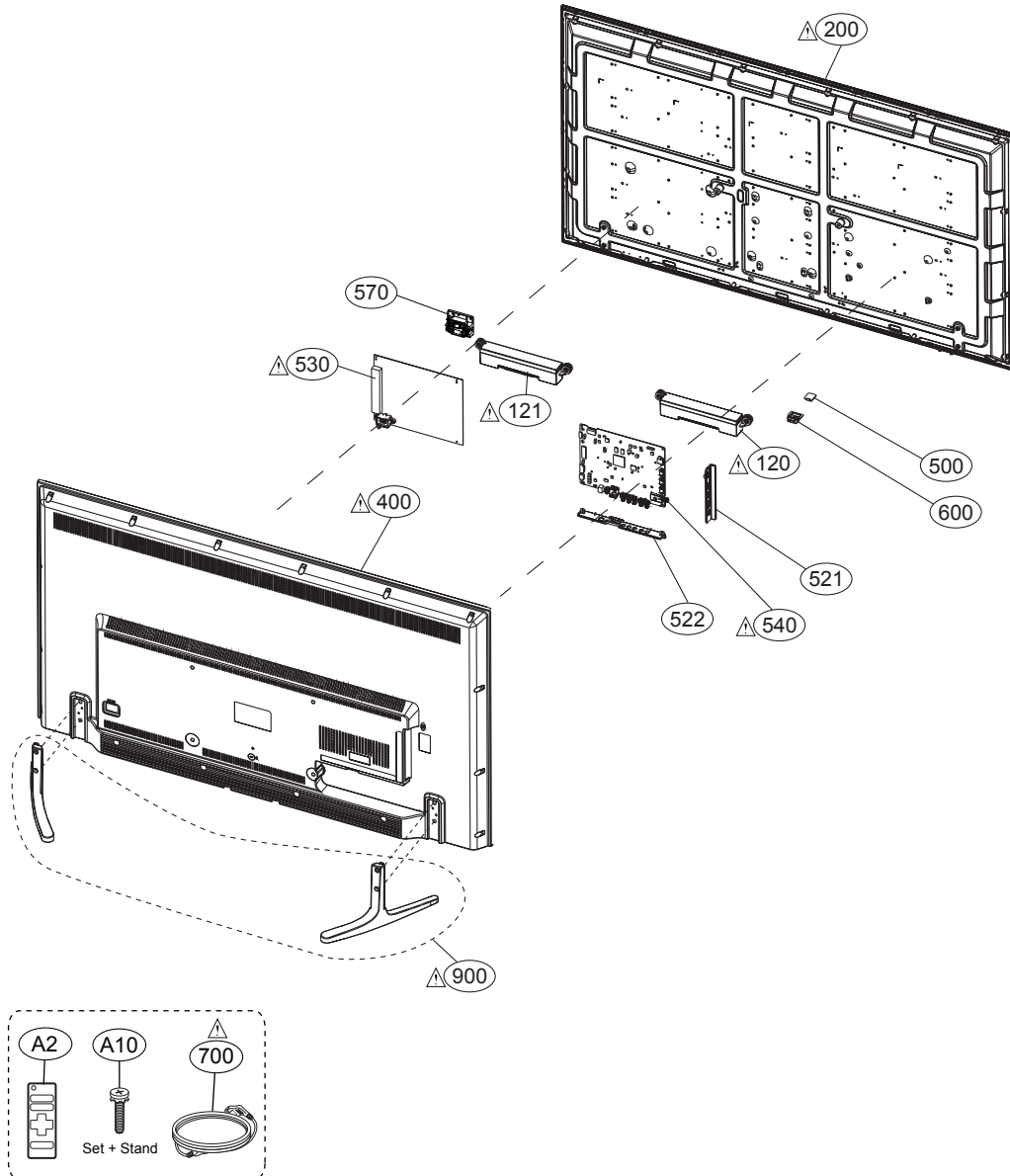

Product Disassembly Process

List the basic steps that should typically be followed to remove components and materials requiring selective treatment:

1	Unlock screw ("A-17EA") and ("B-4EA") to separate back cover assembly. Unlock screw ("C-4EA") to separate the base.	[Fig.1]
2	Separate the cushion (D,E) from backcover.	[Fig.2]
3	Unlock screw ("F-5EA") to separate power board . Unlock screw ("F-4EA") to separate main board and AV bracket(G,H). Unlock screw ("F-8EA") to separate wall mounting bracket.	[Fig.3]
4	Separate the receive assembly from front cover; Separate the receive board from IR LENS; Separate the PC sheet (I) from IR LENS.	[Fig.4]
5	Unlock screw ("A-1EA") to separate wifi assembly from module backcover. Separate the wifi bracket (J) from wifi assembly.	[Fig.5]

1.OPTIONAL: Depending upon the complexity of the disassembly process, a graphic depicting the locations of items contained within the product which require selective treatment (with descriptions and arrows identifying locations) can be inserted below:

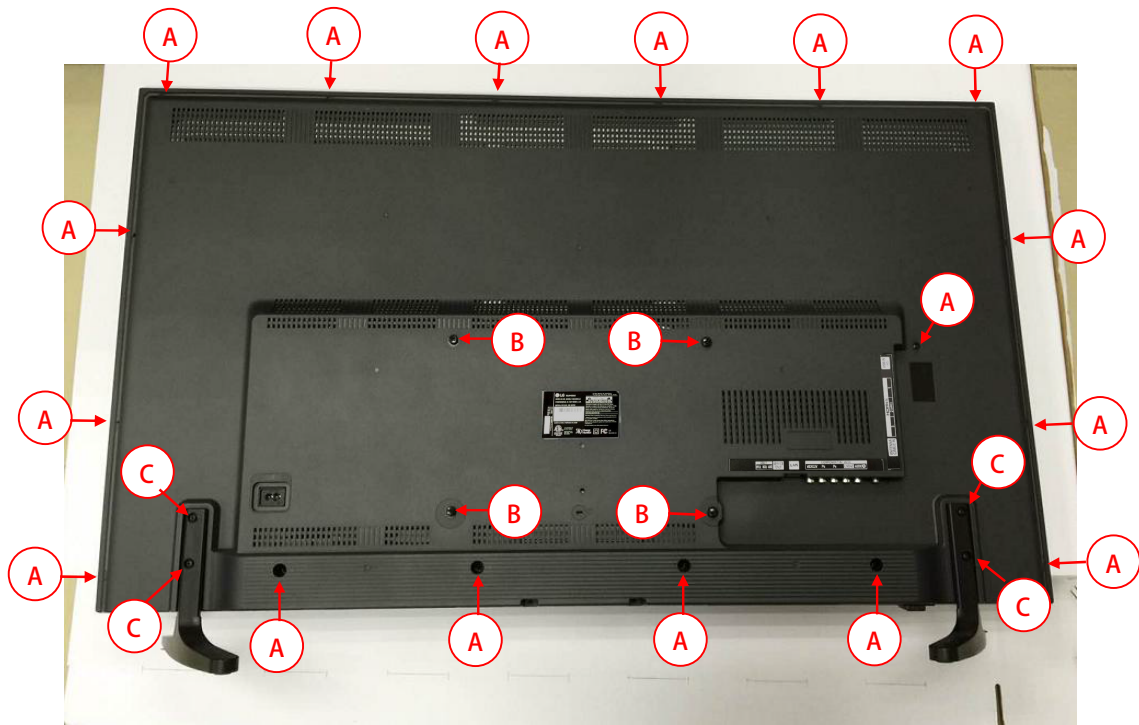

[Fig.1]

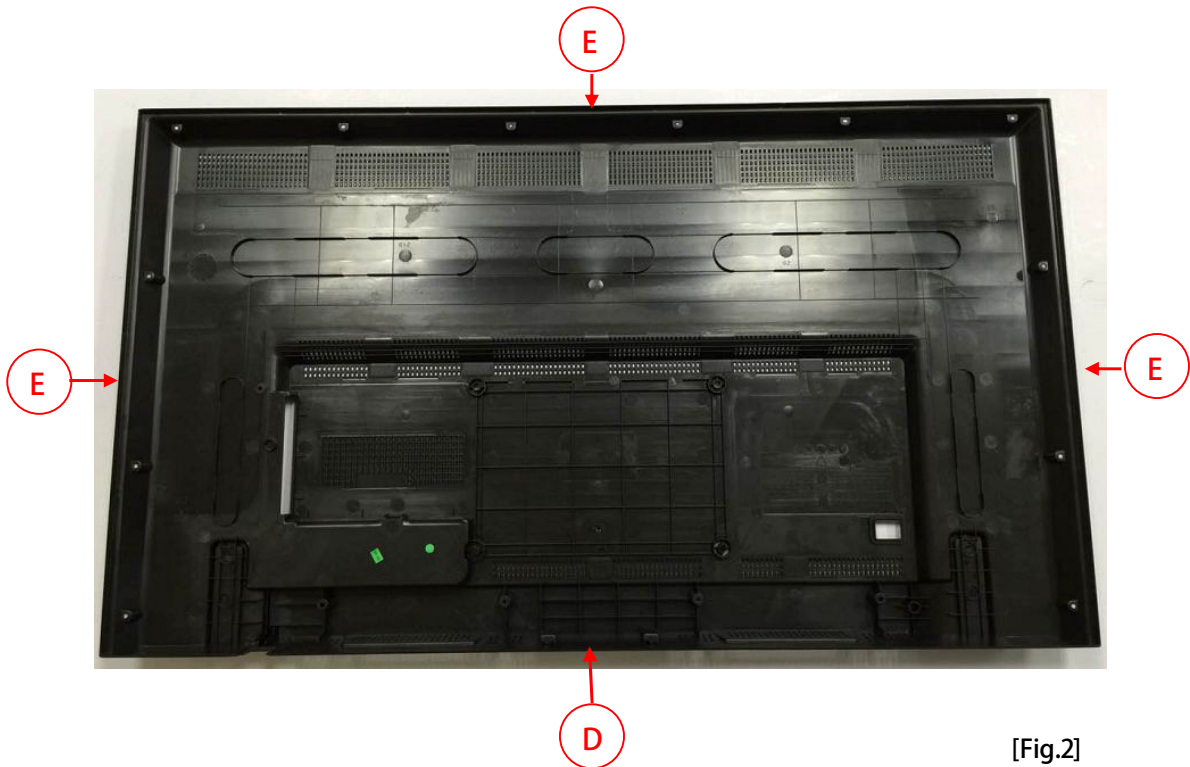

[Fig.2]

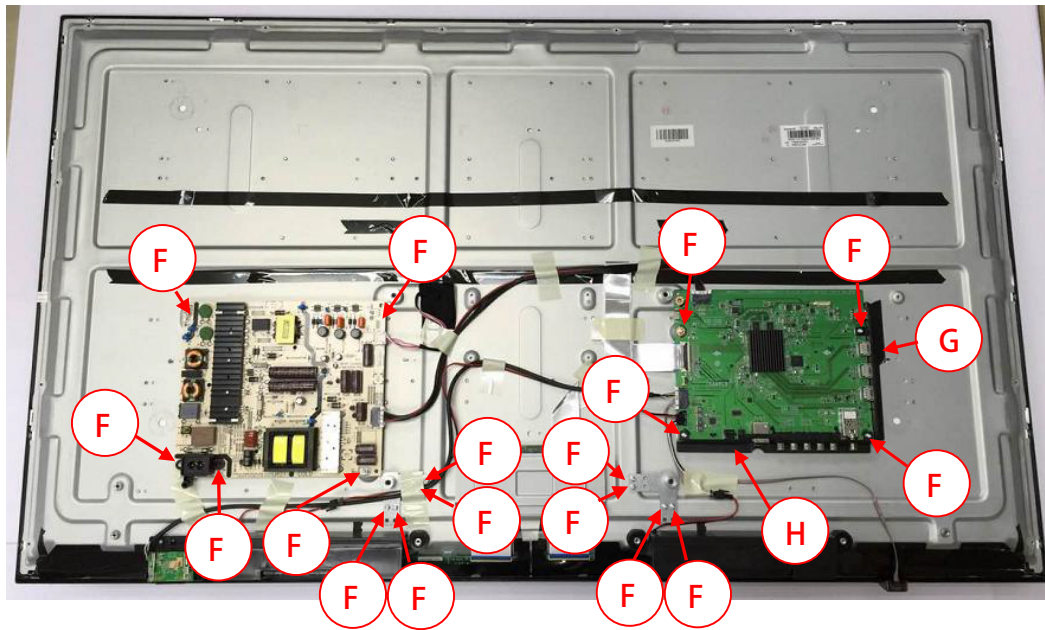

[Fig.3]

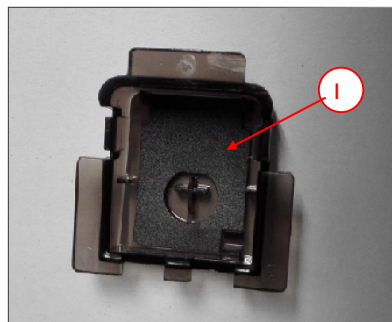
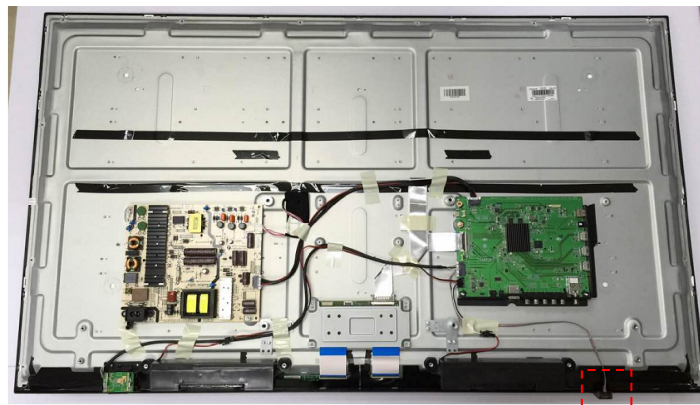

[Fig.4]

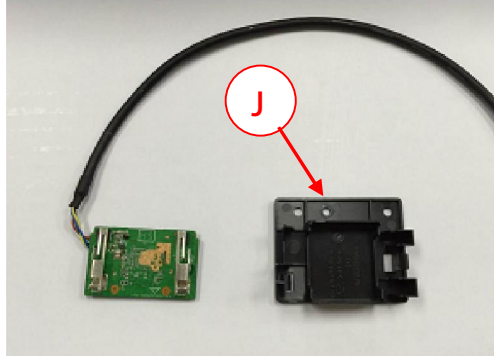
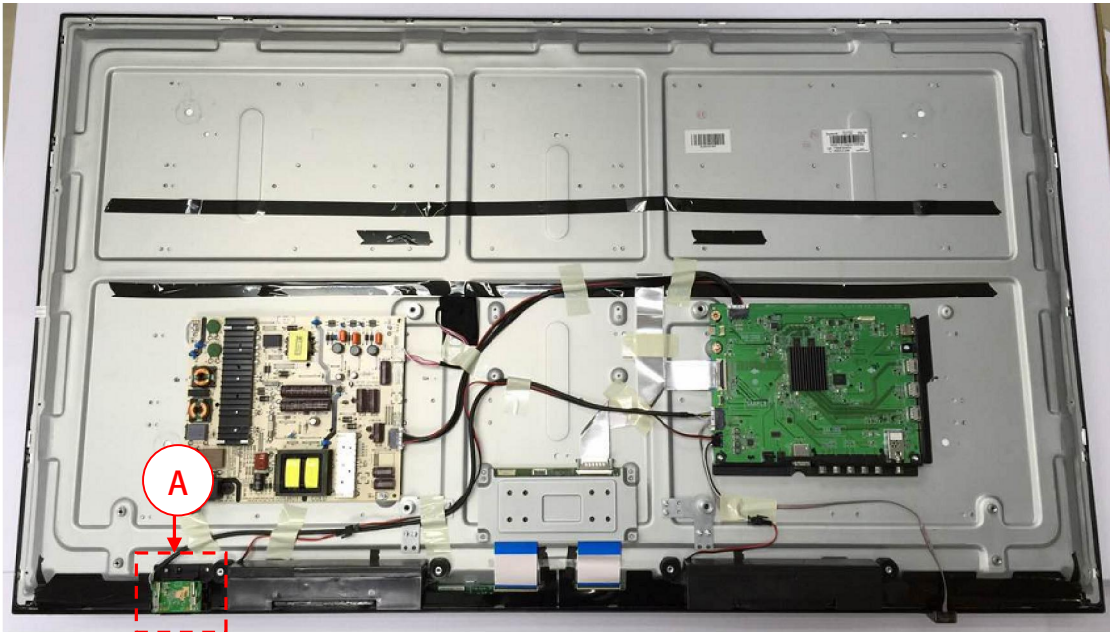

[Fig.5]

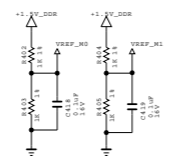
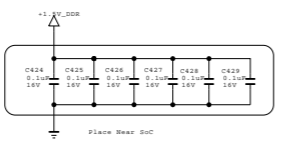
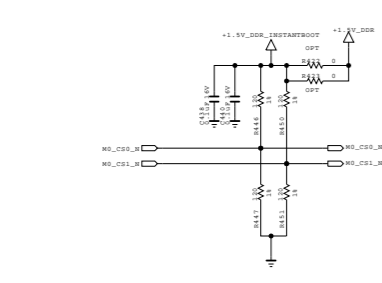
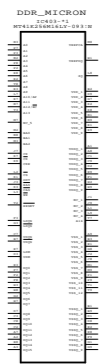
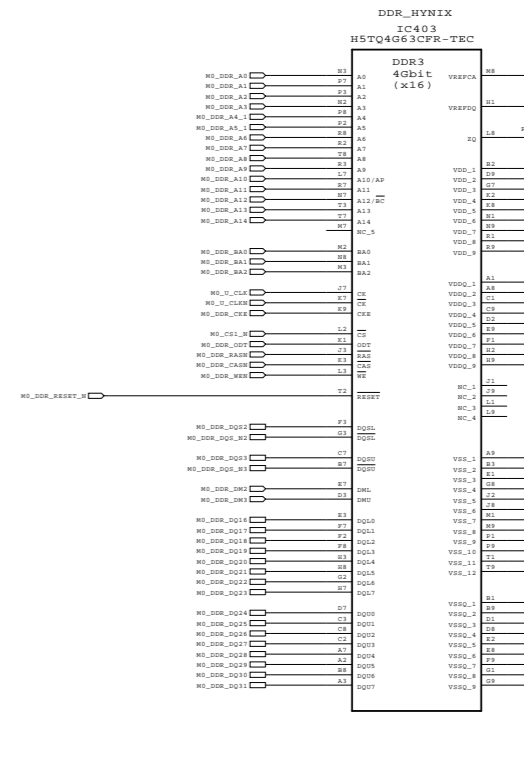
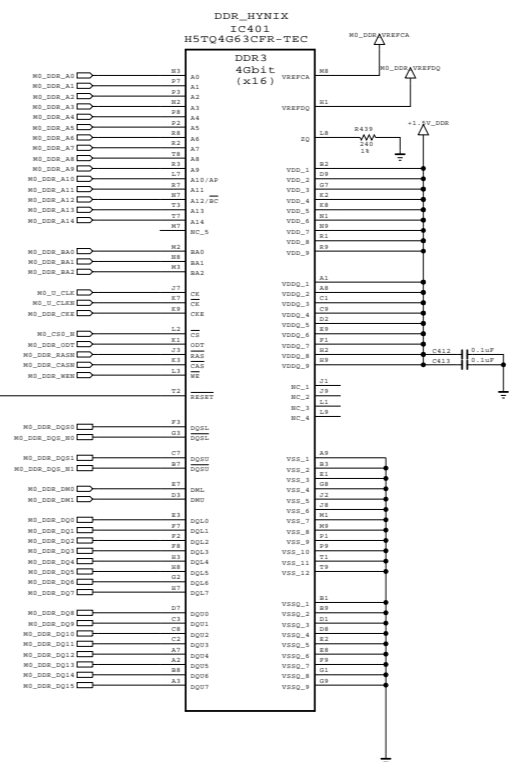
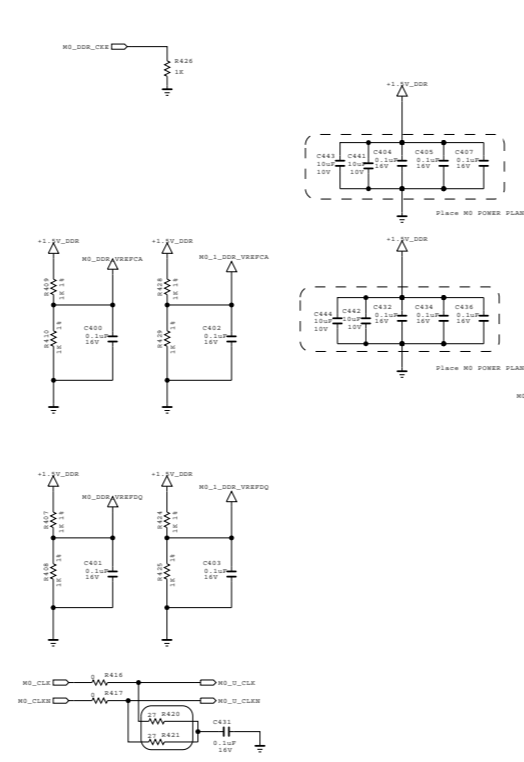
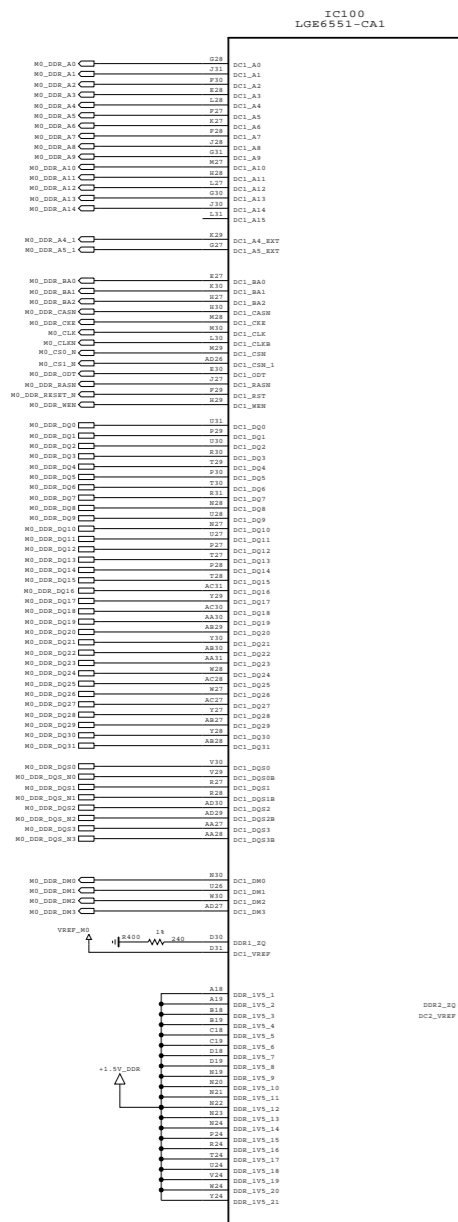

THE SYMBOL MARK OF THIS SCHEMATIC DIAGRAM INCORPORATES SPECIAL FEATURES IMPORTANT FOR PROTECTION FROM X-RADIATION. FIRE AND ELECTRICAL SHOCK HAZARDS, WHEN SERVICING IF IS ESSENTIAL THAT ONLY MANUFACTURERS SPECIFIED PARTS BE USED FOR THE CRITICAL COMPONENTS IN THE SYMBOL MARK OF THE SCHEMATIC.

SECRET
 LGElectronics

LG ELECTRONICS

MODEL	K2L	DATE	2015-04-27
BLOCK	K2L_DDR	SHEET	03

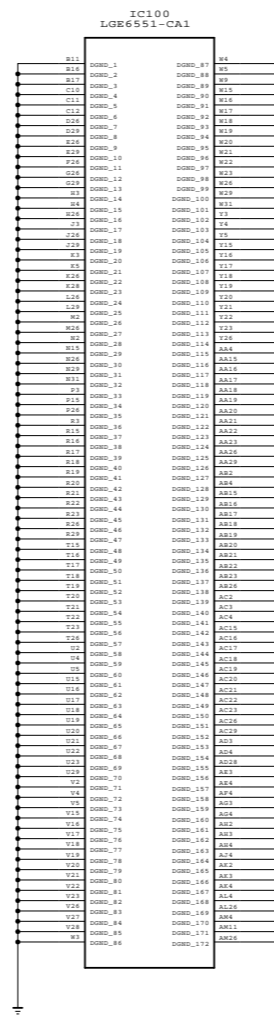

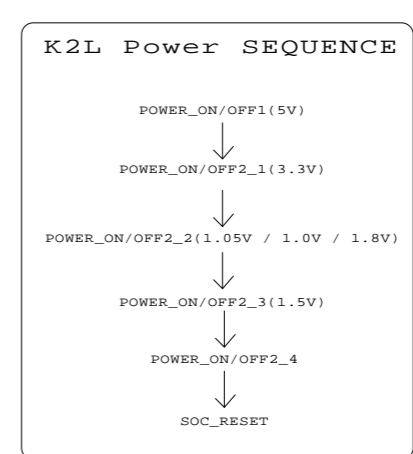
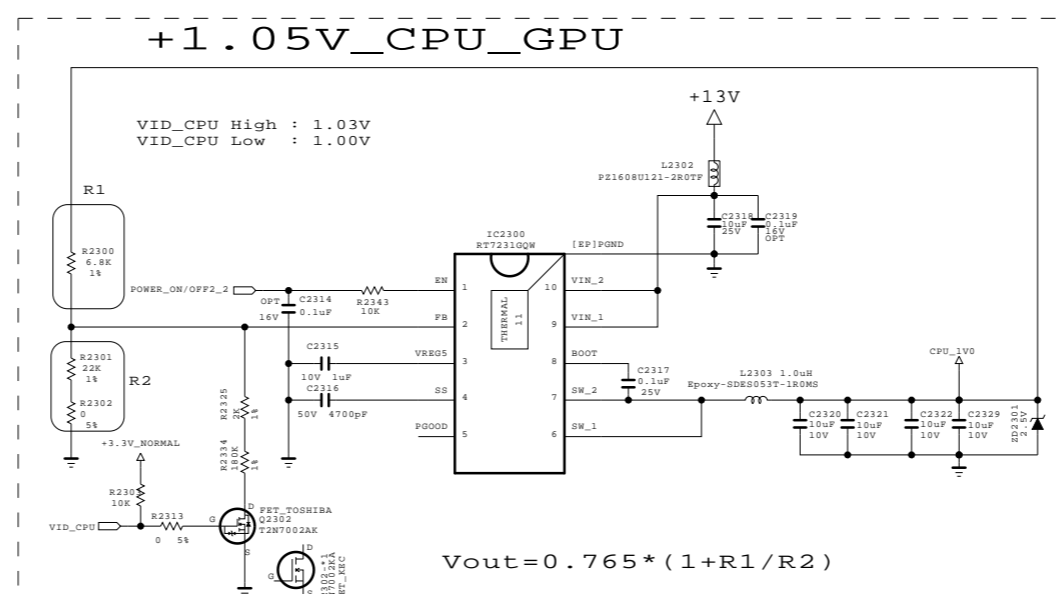
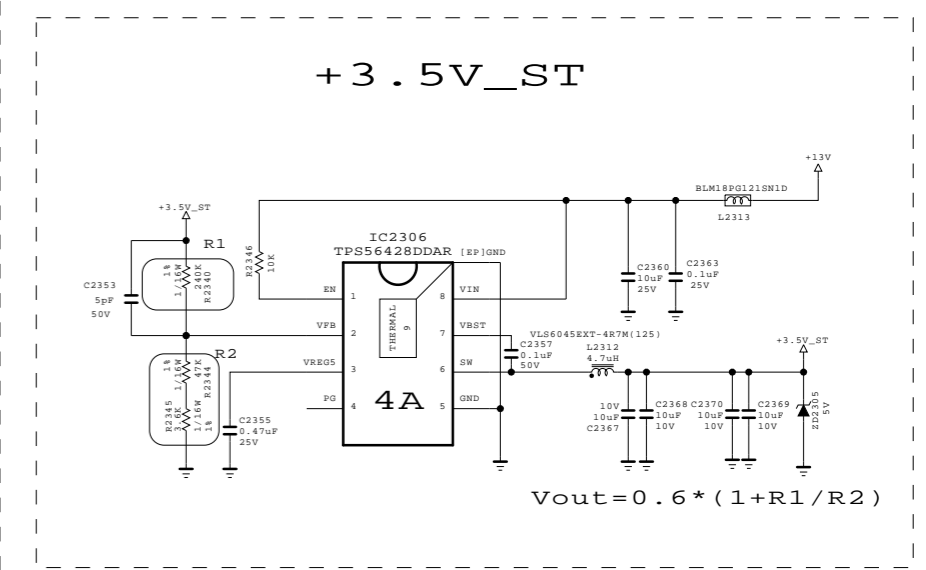
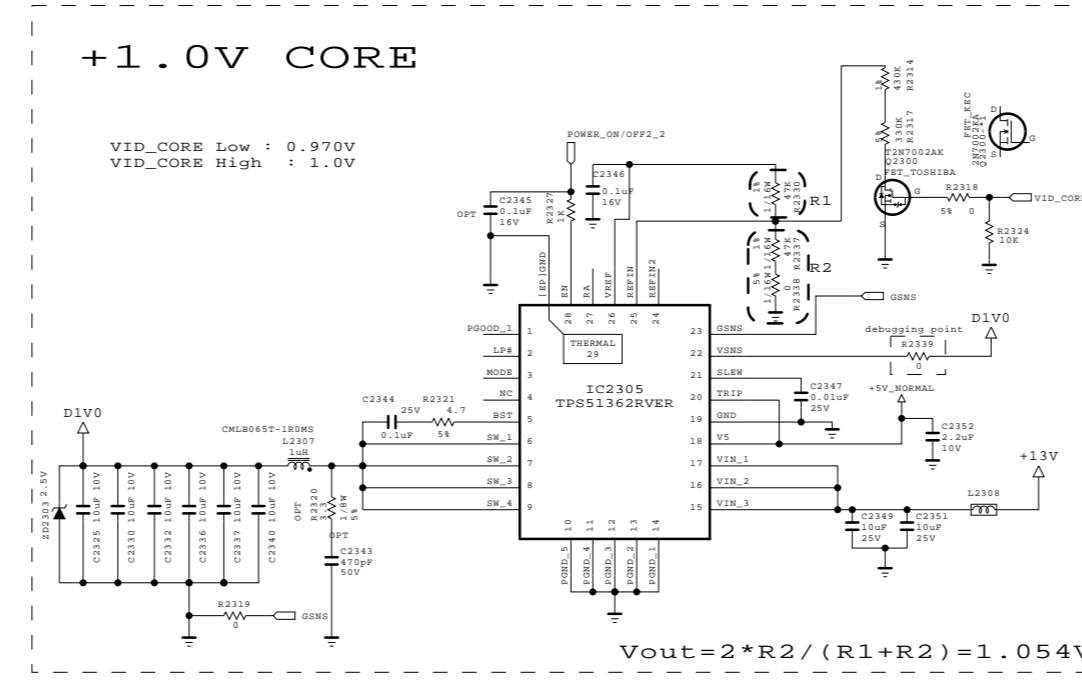
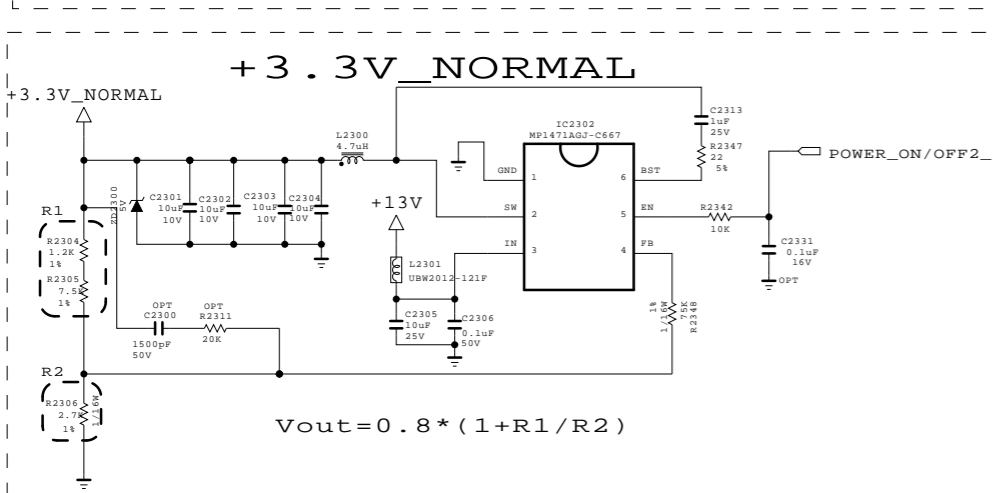
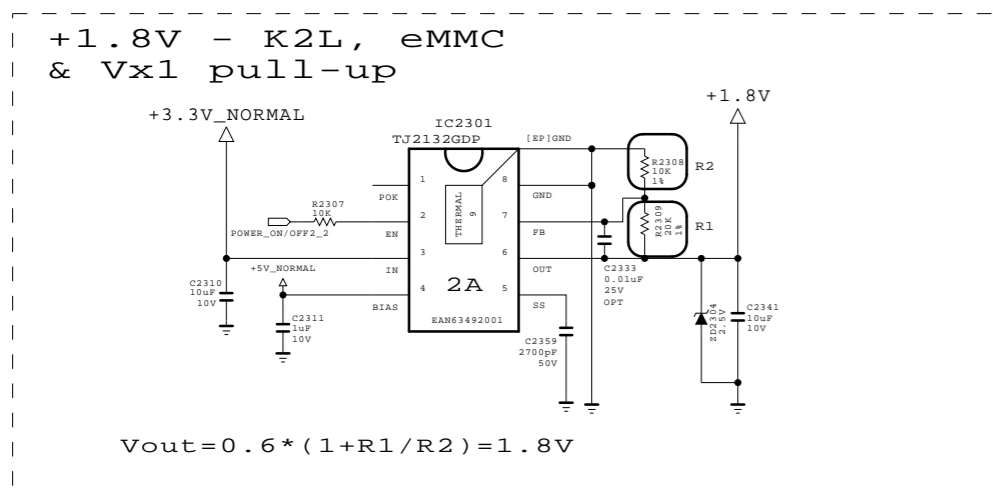
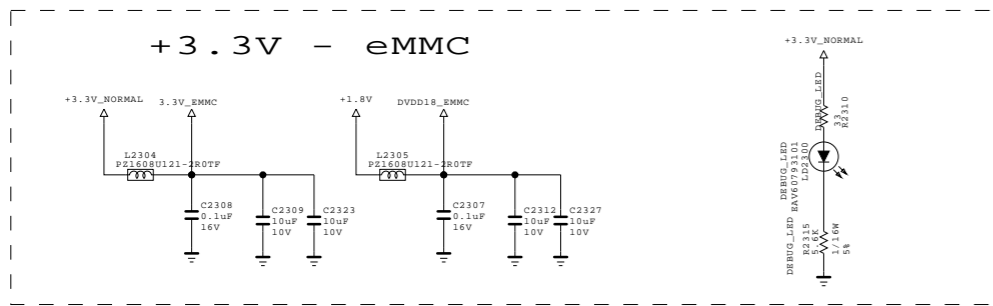
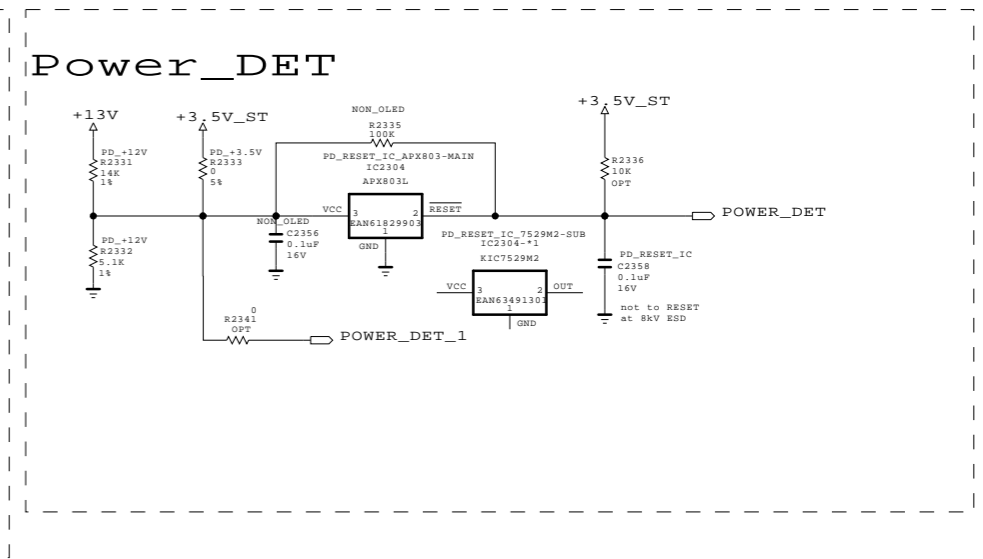
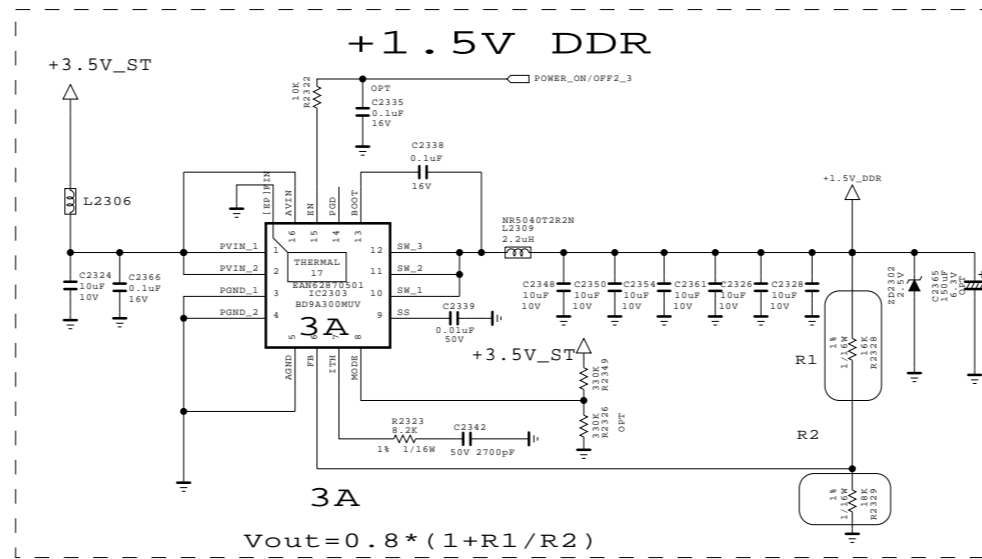

THE SYMBOL MARK OF THIS SCHEMATIC DIAGRAM INCORPORATES SPECIAL FEATURES IMPORTANT FOR PROTECTION FROM X-RADIATION. FIRE AND ELECTRICAL SHOCK HAZARDS, WHEN SERVICING IF IS ESSENTIAL THAT ONLY MANUFACTURES SPECIFIED PARTS BE USED FOR THE CRITICAL COMPONENTS IN THE SYMBOL MARK OF THE SCHEMATIC.

SECRET
LGElectronics



MODEL	K2H	DATE	2015-01-10
BLOCK	PWR_1	SHEET	07

Renesas MICOM

For Debug

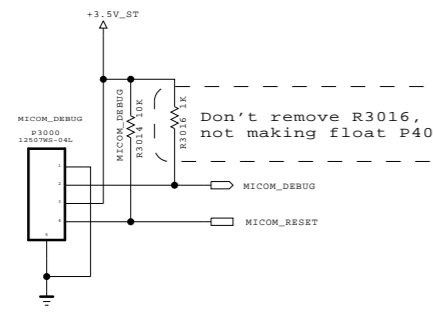

K2L Power SEQUENCE

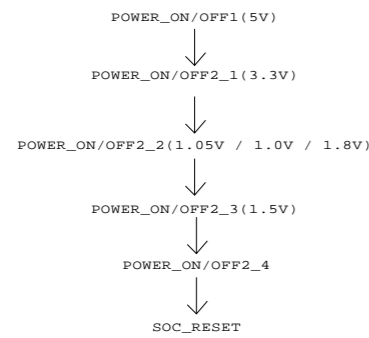

MICOM MODEL OPTION

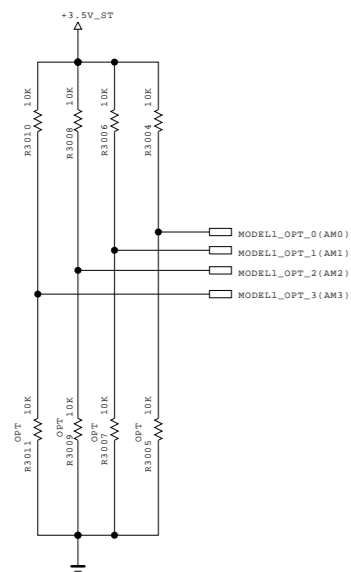

MICOM MODEL OPTION

	0.72V	1.53V	2.27V	3.0V
MODEL_OPT_0	NON LOGO / LCD	LOGO / LCD	NON LOGO / OLED	LOGO / OLED
MODEL_OPT_1	TV	BOX	TV	BOX
MODEL_OPT_2	FHD		UHD	8K
MODEL_OPT_3 (FHD)	M16		ASLR	M2
MODEL_OPT_3 (UHD)	M16	RTK	H15	

For CEC

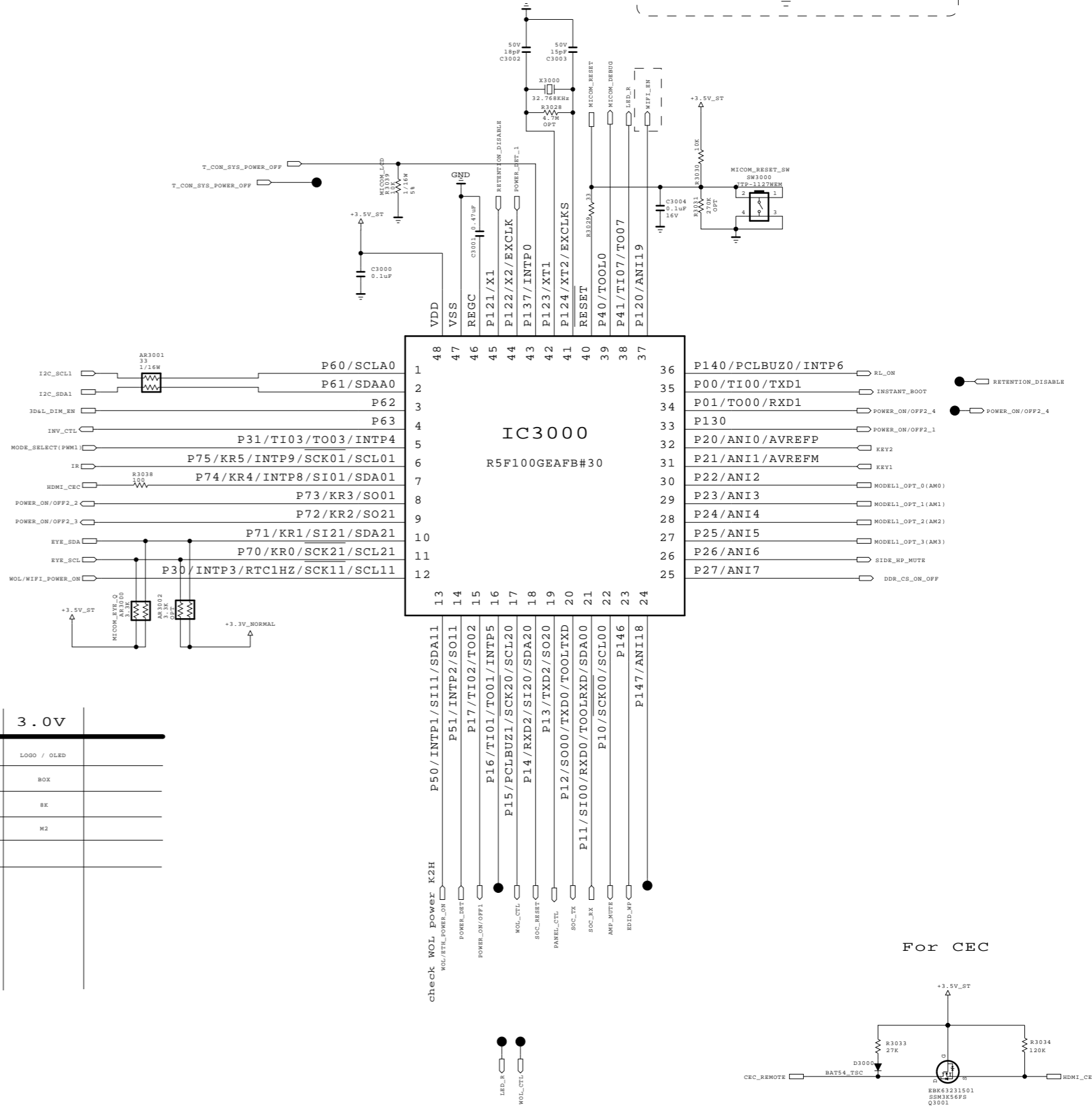
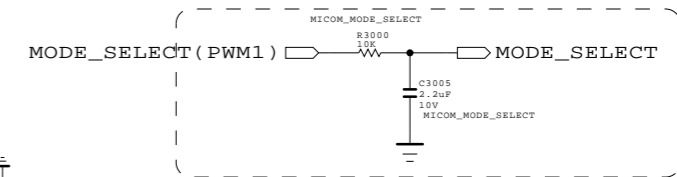
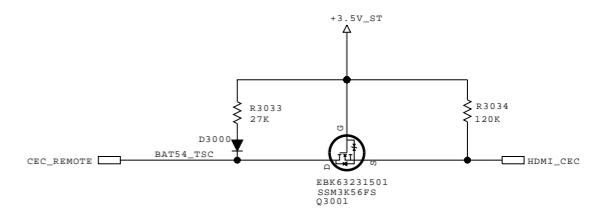

THE SYMBOL MARK OF THIS SCHEMATIC DIAGRAM INCORPORATES SPECIAL FEATURES IMPORTANT FOR PROTECTION FROM X-RADIATION. FIRE AND ELECTRICAL SHOCK HAZARDS, WHEN SERVICING IF IS ESSENTIAL THAT ONLY MANUFACTURERS SPECIFIED PARTS BE USED FOR THE CRITICAL COMPONENTS IN THE SYMBOL MARK OF THE SCHEMATIC.

SECRET
LGElectronics





MODEL	K2L / K2Lp	DATE	2015-06-13
BLOCK	MICOM	SHEET	30 /

MICOM MODEL OPTION

	0.72V (2.7K)	1.53V (8.2K)	2.27V (20K)	3.0V (75K)
MODEL_OPT_0(AM0)	NON LOGO / LCD	LOGO / LCD	NON LOGO / OLED	LOGO / OLED
MODEL_OPT_1(AM1)	TV_NON_EPI	BOX_NON_EPI	TV_EPI	BOX_NON_EPI
MODEL_OPT_2(AM2)	FHD		URD	8K
MODEL_OPT_3(AM3) (FHD)	M16		A5LR	M2
MODEL_OPT_3(AM3) (URD)	M16	RTK	M15	

	0.72V (2.7K)	1.53V (8.2K)	2.27V (20K)	3.0V (75K)
MODEL_OPT_0(AM0)	MICOM_NON_LOGO/LCD R3005-*1 2.7K	MICOM_LOGO/LCD R3005-*2 8.2K	MICOM_NON_LOGO/OLED R3005-*3 20K	MICOM_LOGO/OLED R3005-*4 75K
MODEL_OPT_1(AM1)	MICOM_TV_NON_EPI R3007-*1 2.7K		MICOM_TV_EPI R3007-*3 20K	
MODEL_OPT_2(AM2)	MICOM_FHD R3009-*1 2.7K		MICOM_URD R3009-*3 20K	MICOM_8K R3009-*4 75K
MODEL_OPT_3(AM3) (FHD)	MICOM_M16 R3011-*1 2.7K	MICOM_RTK R3011-*2 8.2K	MICOM_M15/A5LR R3011-*3 20K	MICOM_M2 R3011-*4 75K
MODEL_OPT_3(AM3) (URD)				

THE  SYMBOL MARK OF THIS SCHEMATIC DIAGRAM INCORPORATES SPECIAL FEATURES IMPORTANT FOR PROTECTION FROM X-RADIATION. FIRE AND ELECTRICAL SHOCK HAZARDS, WHEN SERVICING IF IS ESSENTIAL THAT ONLY MANUFACTURES SPECIFIED PARTS BE USED FOR THE CRITICAL COMPONENTS IN THE  SYMBOL MARK OF THE SCHEMATIC.

SECRET
LGElectronics



MODEL	K2H	DATE	2015-01-10
BLOCK	MODEL OPTION	SHEET	30 /

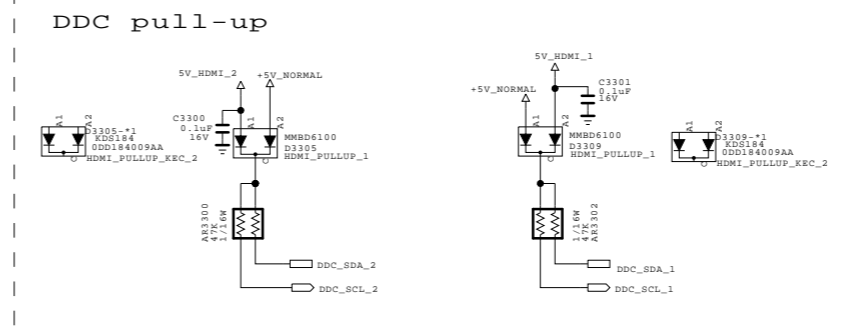
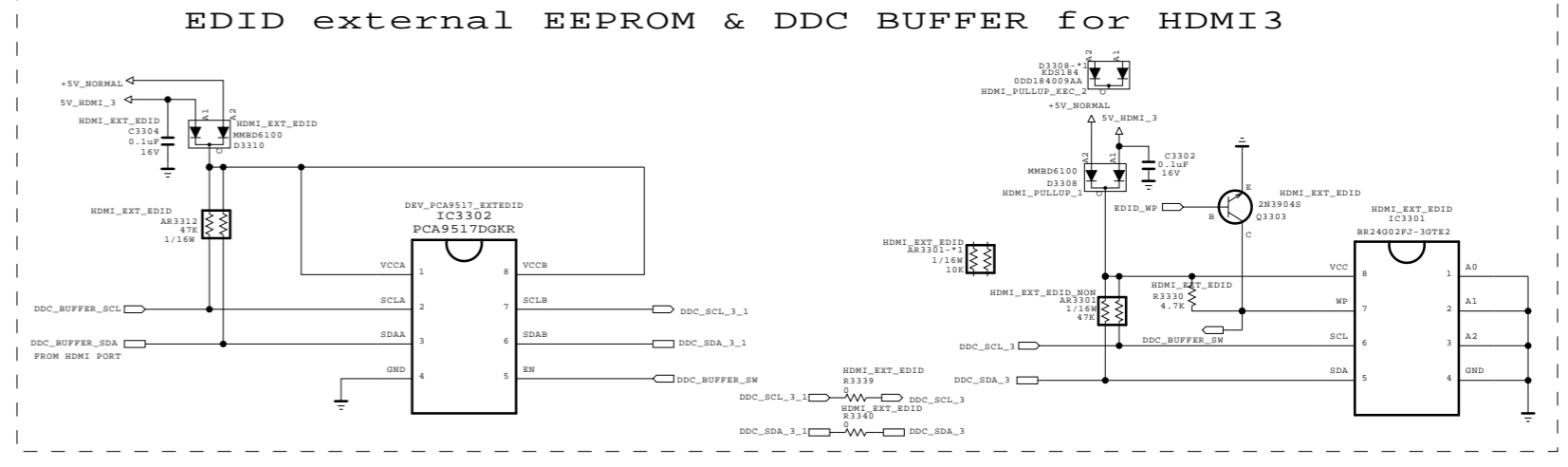
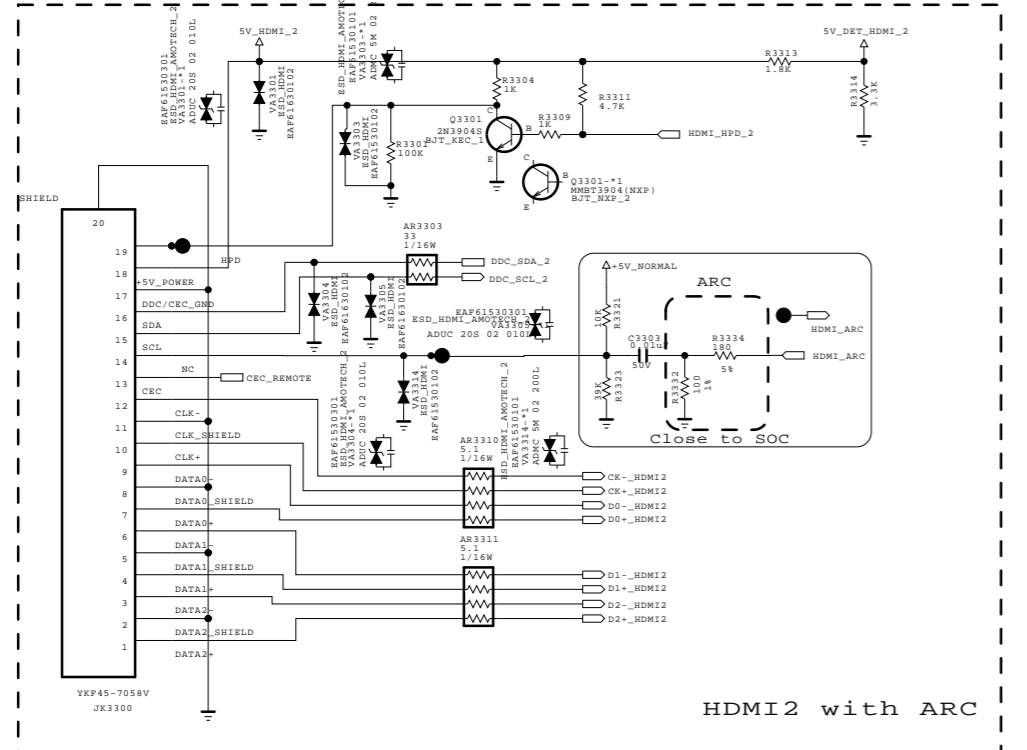
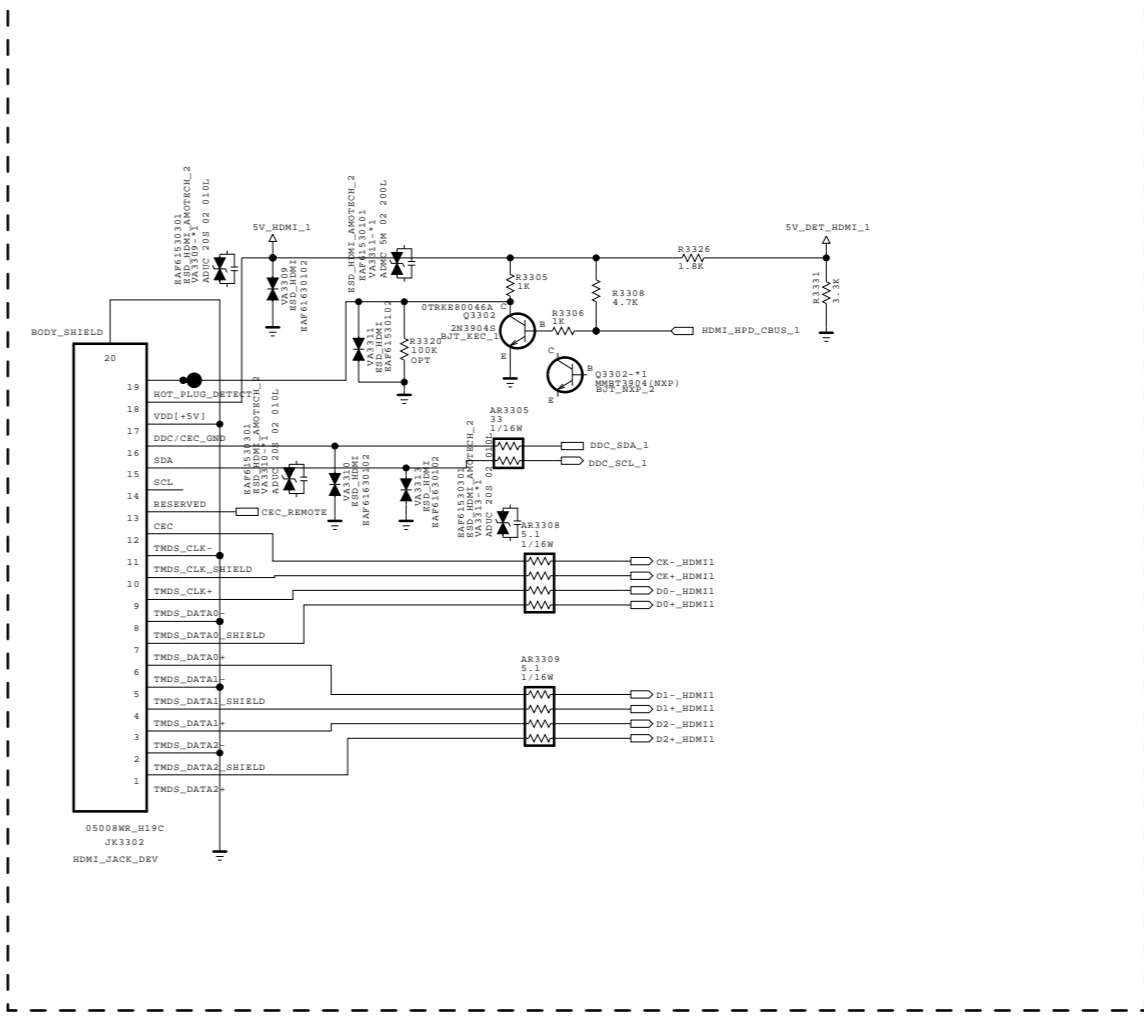
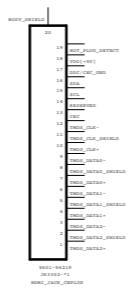
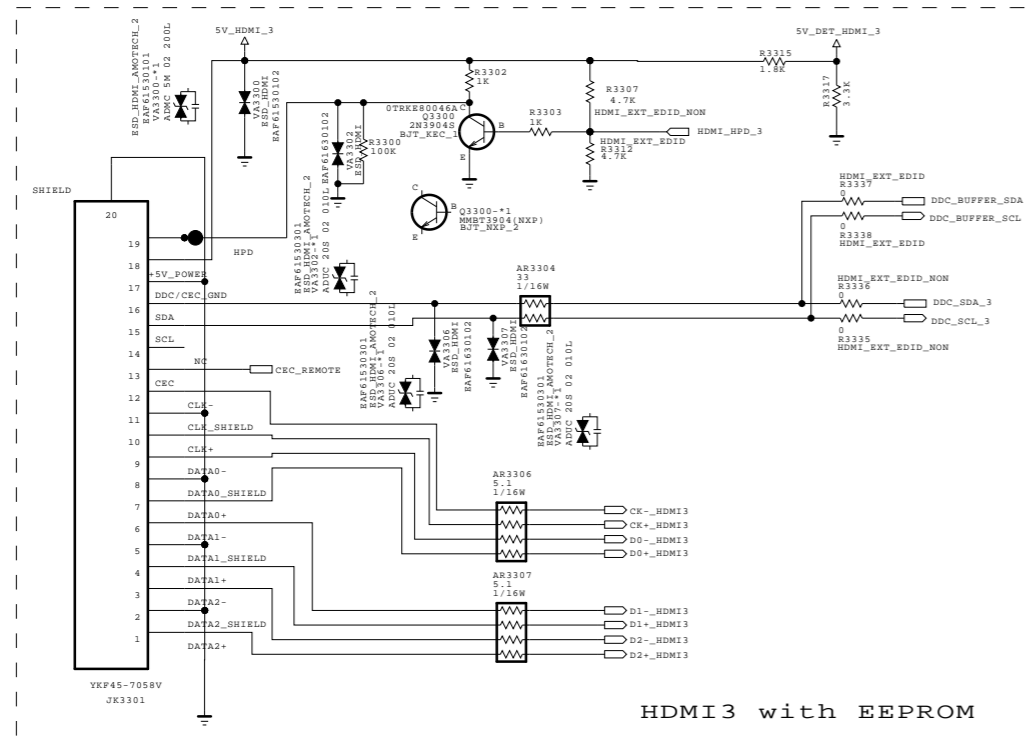

THE SYMBOL MARK OF THIS SCHEMATIC DIAGRAM INCORPORATES SPECIAL FEATURES IMPORTANT FOR PROTECTION FROM X-RADIATION. FIRE AND ELECTRICAL SHOCK HAZARDS, WHEN SERVICING IF IS ESSENTIAL THAT ONLY MANUFACTURES SPECIFIED PARTS BE USED FOR THE CRITICAL COMPONENTS IN THE SYMBOL MARK OF THE SCHEMATIC.

SECRET
LGElectronics



MODEL	K2L	DATE	2015-01-10
BLOCK	HDMI	SHEET	33

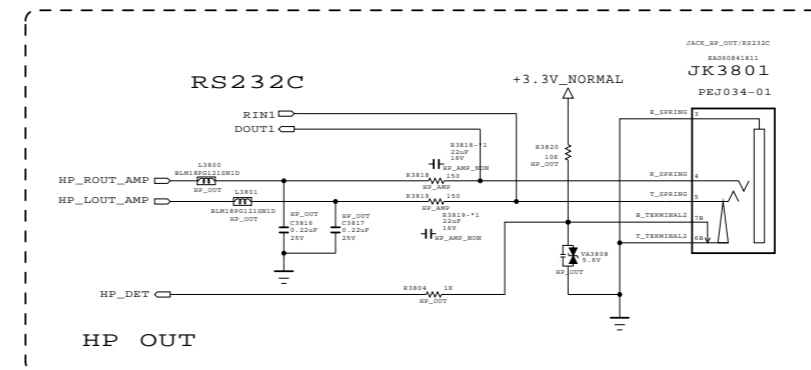
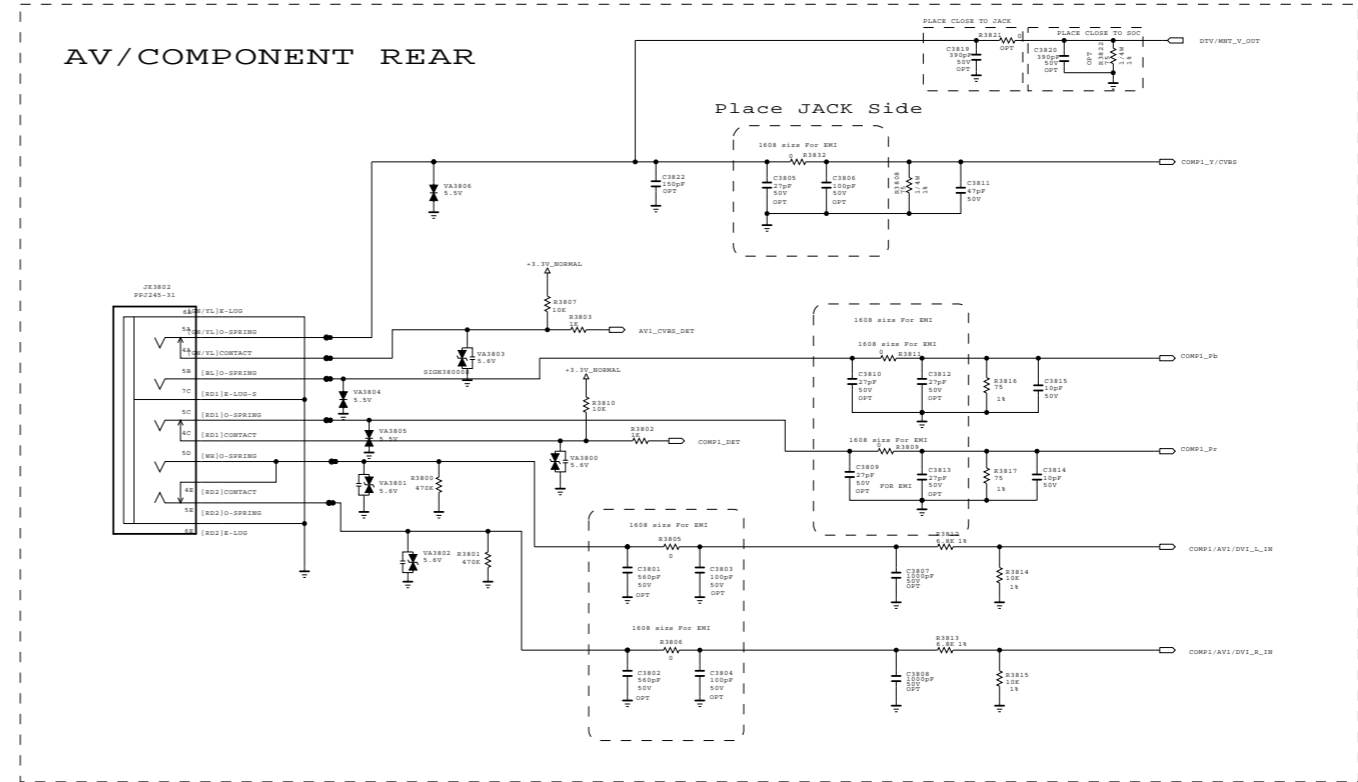
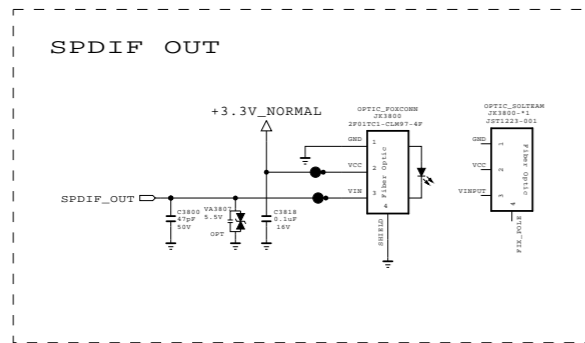

THE SYMBOL MARK OF THIS SCHEMATIC DIAGRAM INCORPORATES SPECIAL FEATURES IMPORTANT FOR PROTECTION FROM X-RADIATION. FIRE AND ELECTRICAL SHOCK HAZARDS, WHEN SERVICING IF IS ESSENTIAL THAT ONLY MANUFACTURERS SPECIFIED PARTS BE USED FOR THE CRITICAL COMPONENTS IN THE SYMBOL MARK OF THE SCHEMATIC.

SECRET
LGElectronics

LG ELECTRONICS

MODEL	UF71/7500	DATE	2014-07-24
BLOCK	JACK_COMMON_H	SHEET	38 /

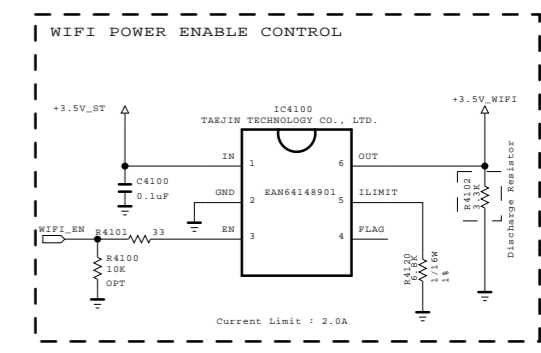
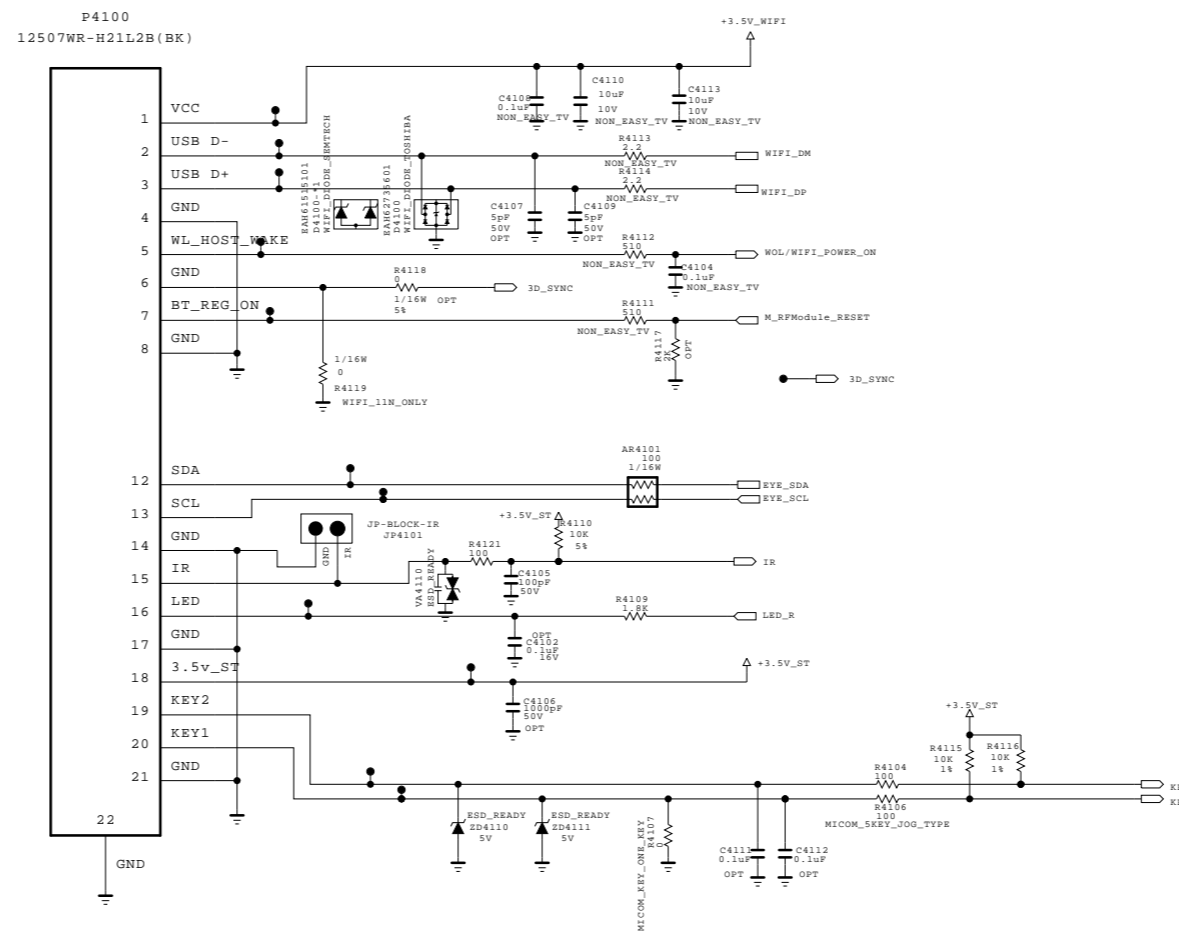
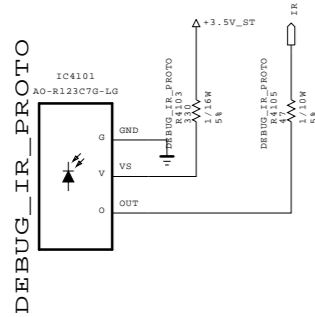

THE SYMBOL MARK OF THIS SCHEMATIC DIAGRAM INCORPORATES SPECIAL FEATURES IMPORTANT FOR PROTECTION FROM X-RADIATION. FIRE AND ELECTRICAL SHOCK HAZARDS, WHEN SERVICING IF IS ESSENTIAL THAT ONLY MANUFACTURES SPECIFIED PARTS BE USED FOR THE CRITICAL COMPONENTS IN THE SYMBOL MARK OF THE SCHEMATIC.

SECRET
LGElectronics





MODEL	UF71/7500	DATE	2014-05-19
BLOCK	IR/KEY	SHEET	12 /

USB2.0 2Port

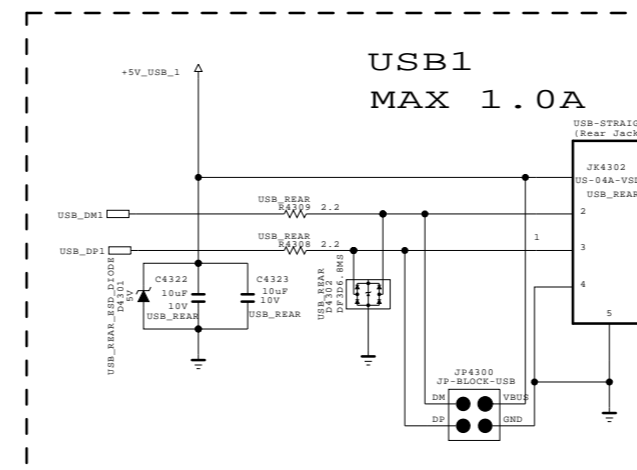
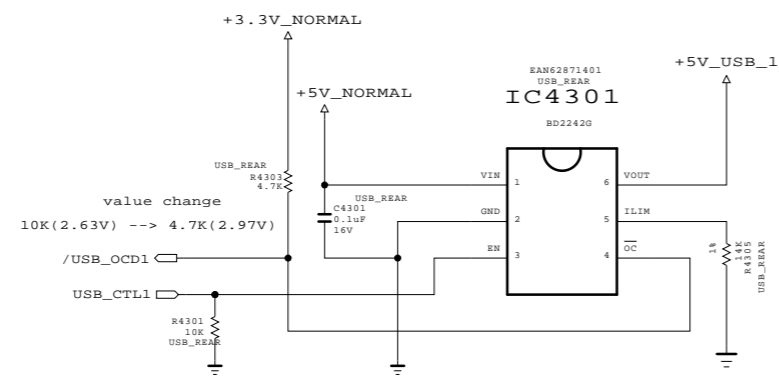
OCP USB2_2.0



THE  SYMBOL MARK OF THIS SCHEMATIC DIAGRAM INCORPORATES SPECIAL FEATURES IMPORTANT FOR PROTECTION FROM X-RADIATION. FIRE AND ELECTRICAL SHOCK HAZARDS, WHEN SERVICING IF IS ESSENTIAL THAT ONLY MANUFACTURES SPECIFIED PARTS BE USED FOR THE CRITICAL COMPONENTS IN THE  SYMBOL MARK OF THE SCHEMATIC.

SECRET
LGElectronics



MODEL	K2L	DATE	2015-04-27
BLOCK	USB2.0 jack	SHEET	13 /

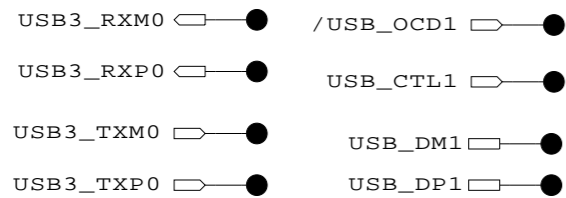
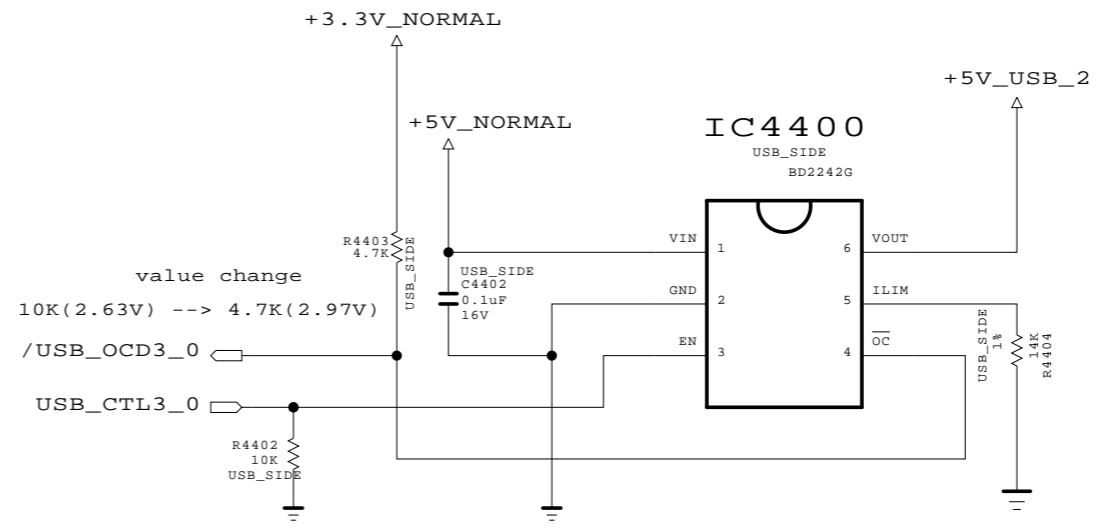
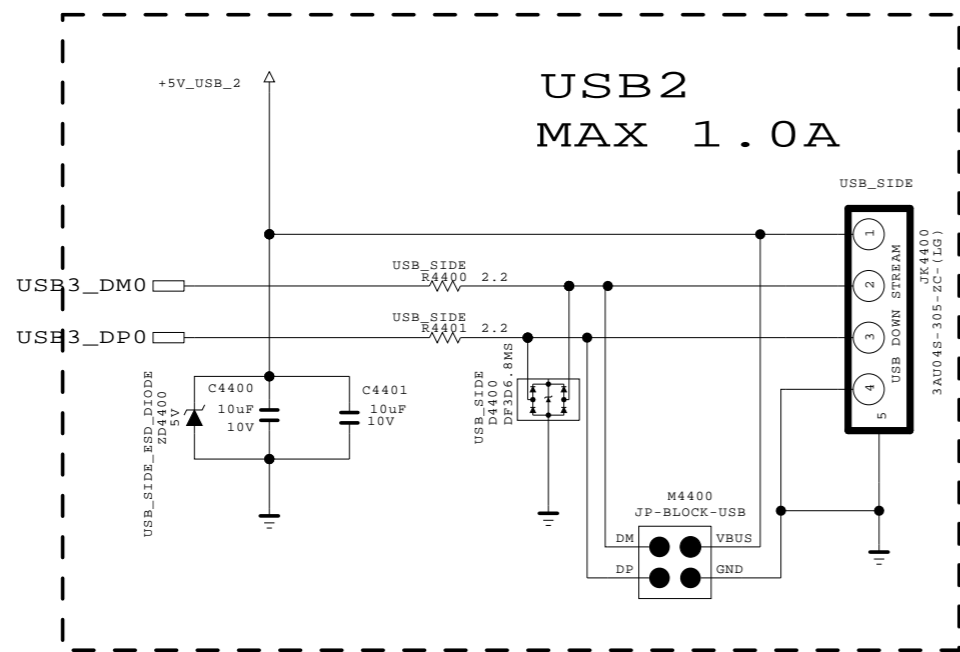

THE SYMBOL MARK OF THIS SCHEMATIC DIAGRAM INCORPORATES SPECIAL FEATURES IMPORTANT FOR PROTECTION FROM X-RADIATION. FIRE AND ELECTRICAL SHOCK HAZARDS, WHEN SERVICING IF IS ESSENTIAL THAT ONLY MANUFACTURERS SPECIFIED PARTS BE USED FOR THE CRITICAL COMPONENTS IN THE SYMBOL MARK OF THE SCHEMATIC.

SECRET
LGElectronics



MODEL	K2H	DATE	2015.02.11
BLOCK	USB 2 & 3	SHEET	15 / 26

043.sht

Ethernet Block

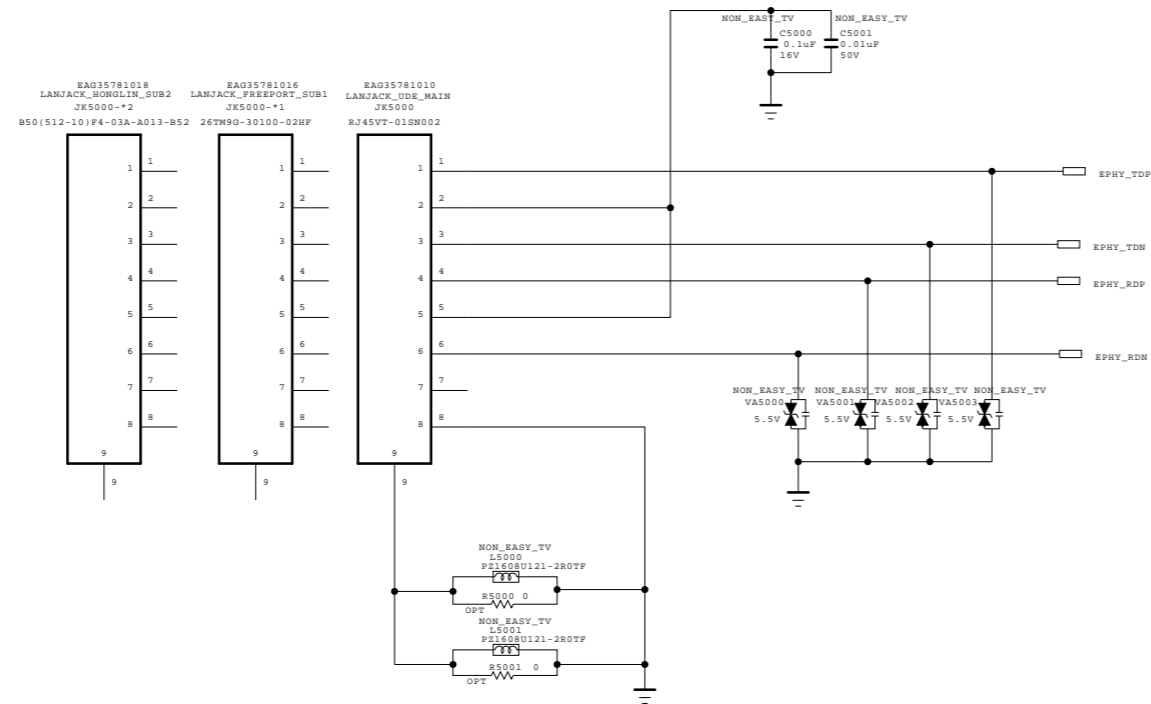

THE SYMBOL MARK OF THIS SCHEMATIC DIAGRAM INCORPORATES SPECIAL FEATURES IMPORTANT FOR PROTECTION FROM X-RADIATION. FIRE AND ELECTRICAL SHOCK HAZARDS, WHEN SERVICING IF IS ESSENTIAL THAT ONLY MANUFACTURES SPECIFIED PARTS BE USED FOR THE CRITICAL COMPONENTS IN THE SYMBOL MARK OF THE SCHEMATIC.

SECRET
LGElectronics



MODEL	K2H	DATE	2014-12-15
BLOCK	LAN_H	SHEET	50 /

AUDIO AMP (NTP7515)

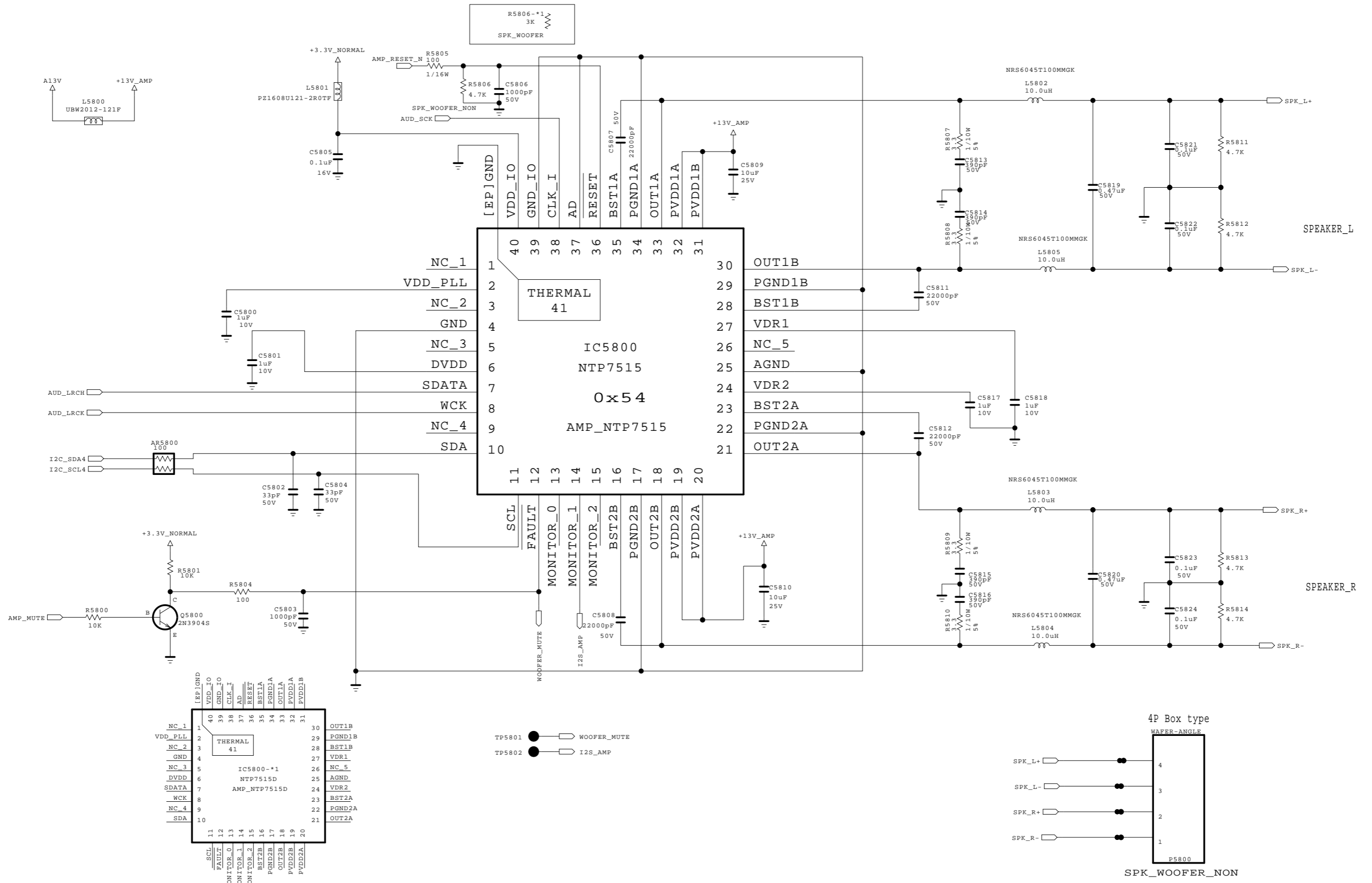



THE ⚠ SYMBOL MARK OF THIS SCHEMATIC DIAGRAM INCORPORATES SPECIAL FEATURES IMPORTANT FOR PROTECTION FROM X-RADIATION. FIRE AND ELECTRICAL SHOCK HAZARDS, WHEN SERVICING IF IS ESSENTIAL THAT ONLY MANUFACTURES SPECIFIED PARTS BE USED FOR THE CRITICAL COMPONENTS IN THE ⚠ SYMBOL MARK OF THE SCHEMATIC.

SECRET	LG ELECTRONICS
LGElectronics	

MODEL		DATE	2014-10-17
BLOCK	MAIN_AMP	SHEET	58 /

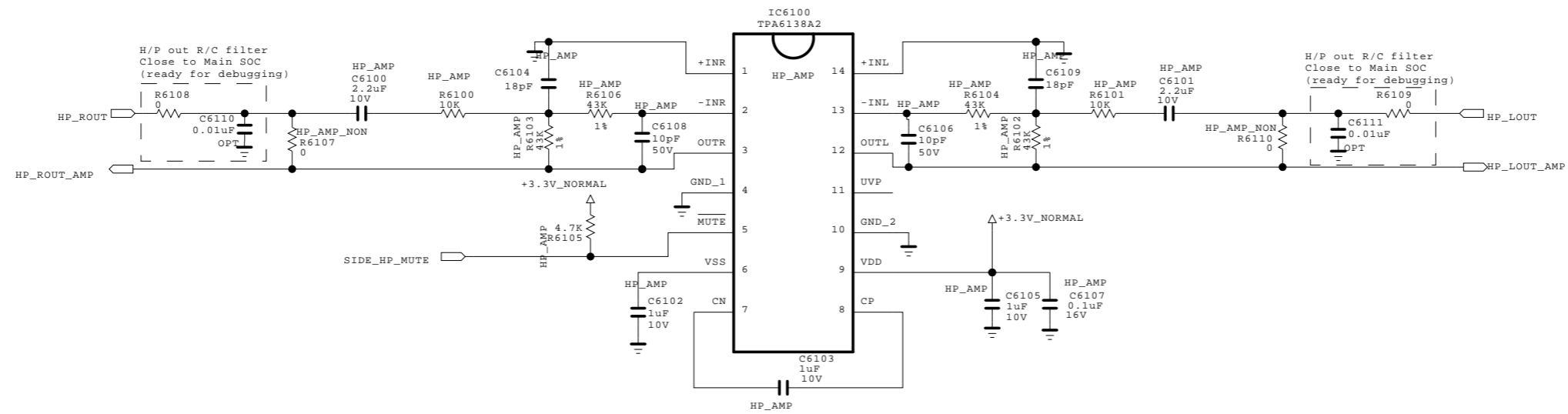
EARPHONE AMP



THE  SYMBOL MARK OF THIS SCHEMATIC DIAGRAM INCORPORATES SPECIAL FEATURES IMPORTANT FOR PROTECTION FROM X-RADIATION. FIRE AND ELECTRICAL SHOCK HAZARDS, WHEN SERVICING IF IS ESSENTIAL THAT ONLY MANUFACTURERS SPECIFIED PARTS BE USED FOR THE CRITICAL COMPONENTS IN THE  SYMBOL MARK OF THE SCHEMATIC.

SECRET
LGElectronics



MODEL	K2H	DATE	2014-11-22
BLOCK	HP_AMP	SHEET	61 /

● FE_DEMOD1_TS_ERROR
● FE_DEMOD2_TS_ERROR

1. should be guarded by ground
2. No via on both of them
3. Signal Width >= 12mils
Signal to Signal Width = 12mils
Ground Width >= 24mils

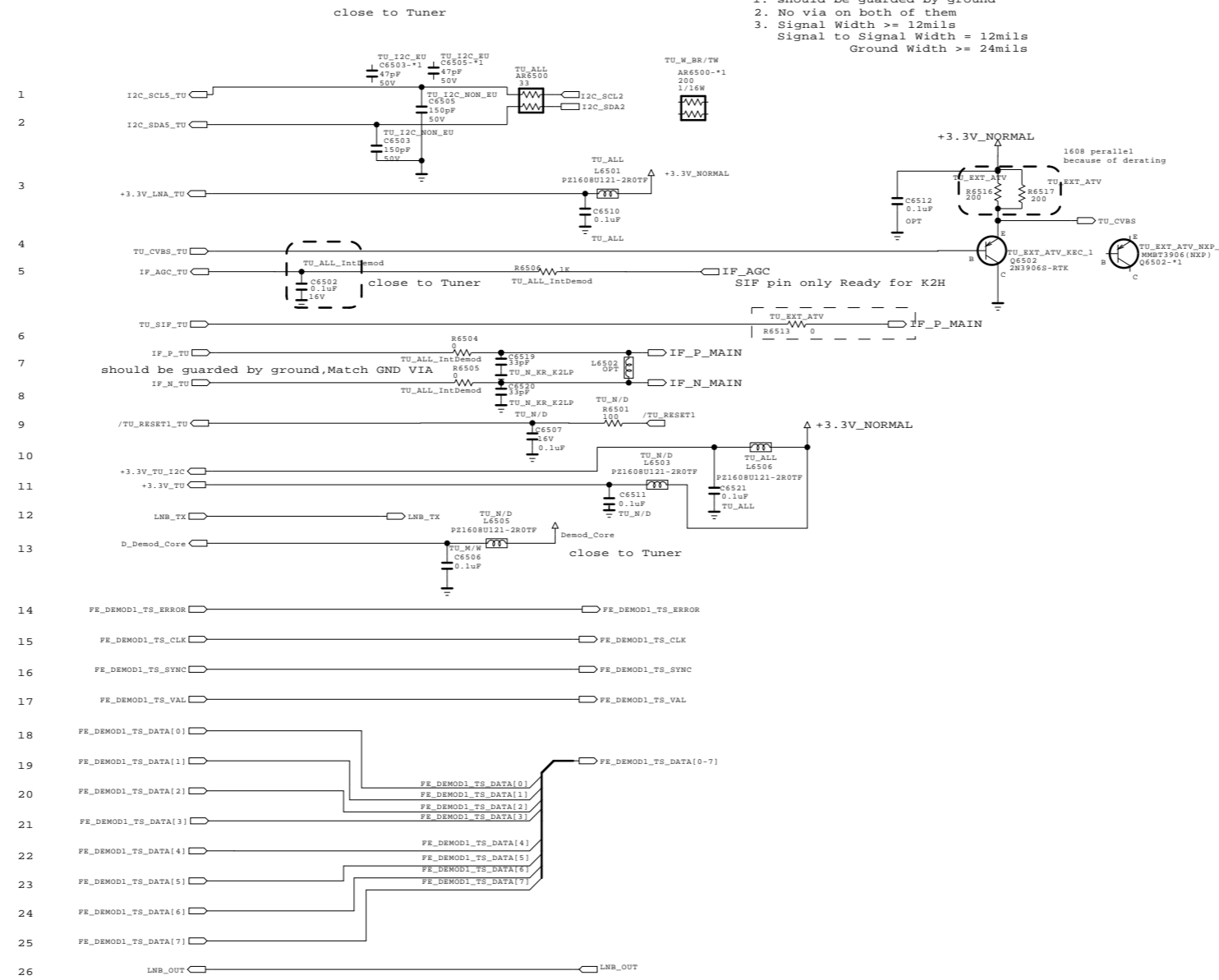

Global F/E Option Name
 1. TU
 2. Tuner Name = TDJ'H',TDj'M'...
 3. Country Name = KR,US,BR,EU ...

Example of Option name
 TU_ALL_IntDemod = All Tuner type for Internal demod
 TU_M/W = apply TDSM&TDSW Type Tuner

14' Tuner Type for Global
 TDJ'H'-G101D : Half NIM for EU,AJJA
 TDJ'H'-H101F : Half NIM for US, KR
 TDJ'K'-T101F : Half NIM for TW
 TDJ'M'-C301D,F : FULL NIM for China
 TDJ'M'-B101F : Brazil NIM with Isolater Type
 TDJ'M'-K101F : colombia NIM
 TDJ'M'-G101D,G105D,G151D : EU Combo&Full NIM
 TDJ'M'-H101F,H151F : Korea PIP tuner
 TDJ'W'-A151D : AJJA T2 PIP

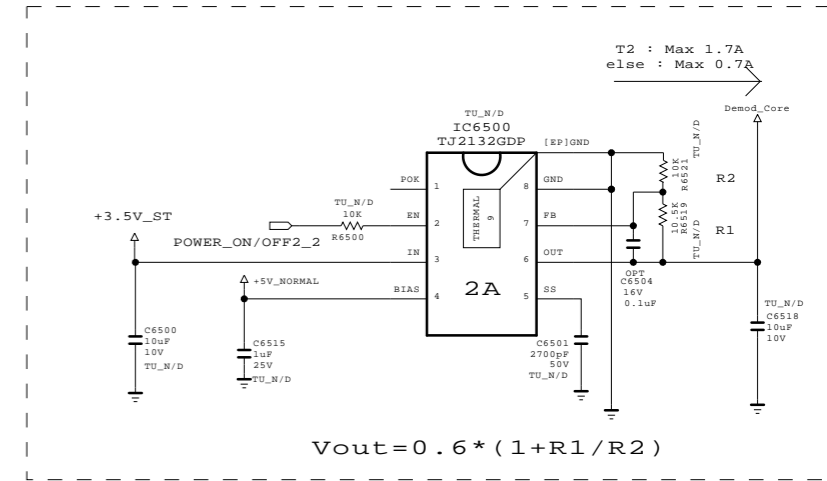

THE SYMBOL MARK OF THIS SCHEMATIC DIAGRAM INCORPORATES SPECIAL FEATURES IMPORTANT FOR PROTECTION FROM X-RADIATION. FIRE AND ELECTRICAL SHOCK HAZARDS, WHEN SERVICING IF IS ESSENTIAL THAT ONLY MANUFACTURES SPECIFIED PARTS BE USED FOR THE CRITICAL COMPONENTS IN THE SYMBOL MARK OF THE SCHEMATIC.

SECRET
 LGElectronics



MODEL	K2H	DATE	2014-10-17
BLOCK	TU_CIRCUIT	SHEET	18

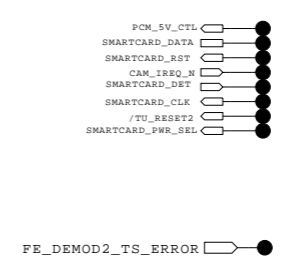
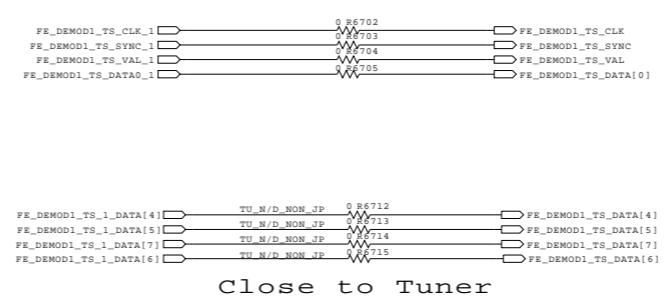
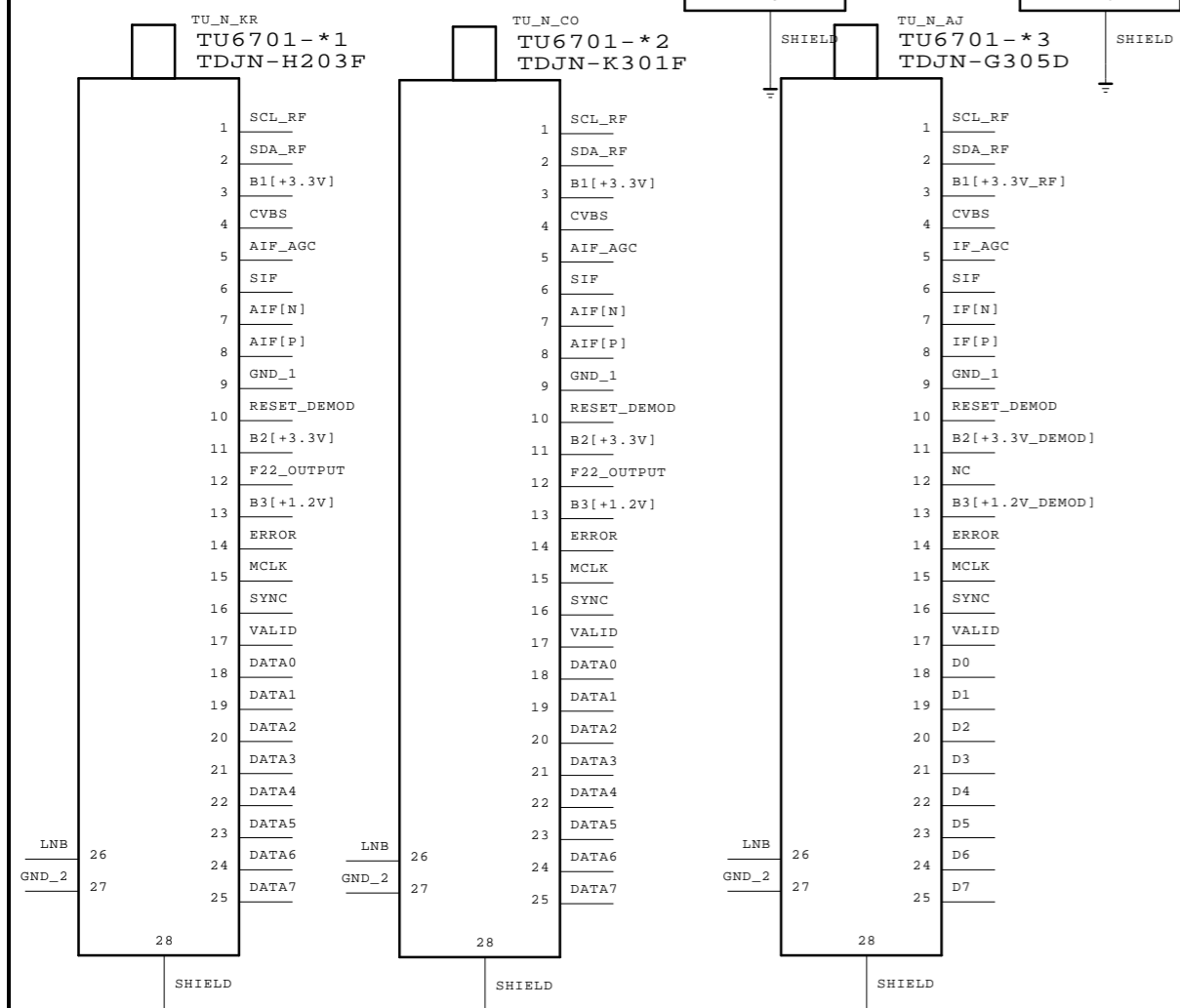
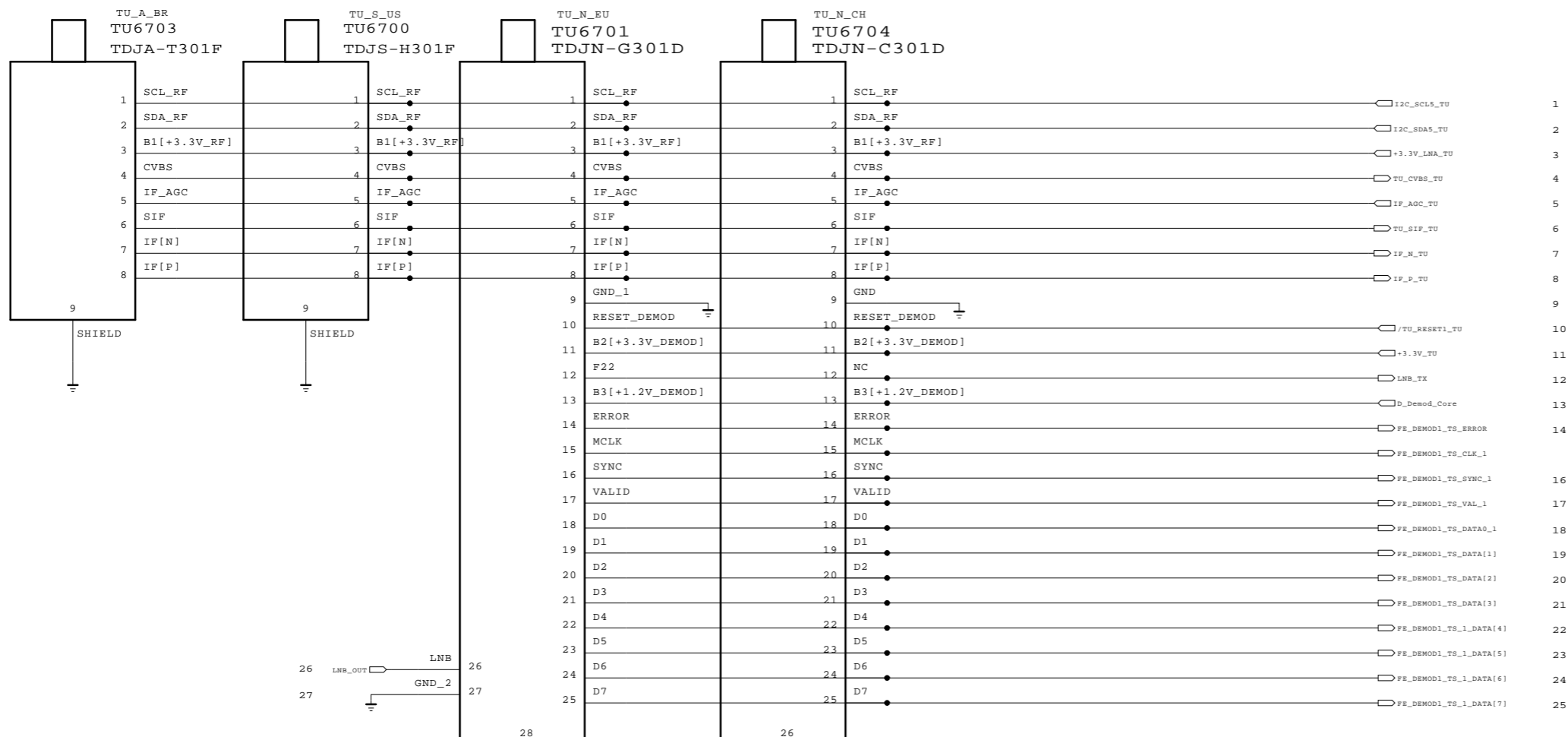

THE SYMBOL MARK OF THIS SCHEMATIC DIAGRAM INCORPORATES SPECIAL FEATURES IMPORTANT FOR PROTECTION FROM X-RADIATION. FIRE AND ELECTRICAL SHOCK HAZARDS, WHEN SERVICING IF IS ESSENTIAL THAT ONLY MANUFACTURES SPECIFIED PARTS BE USED FOR THE CRITICAL COMPONENTS IN THE SYMBOL MARK OF THE SCHEMATIC.

SECRET
 LGElectronics



MODEL	K2H	DATE	2014-09-11
BLOCK	TU_SYMBOL_H	SHEET	19

LNB PART (DVB-S2)

OPTION ; LNB

Input trace widths should be sized to conduct at least 3A
Output trace widths should be sized to conduct at least 2A

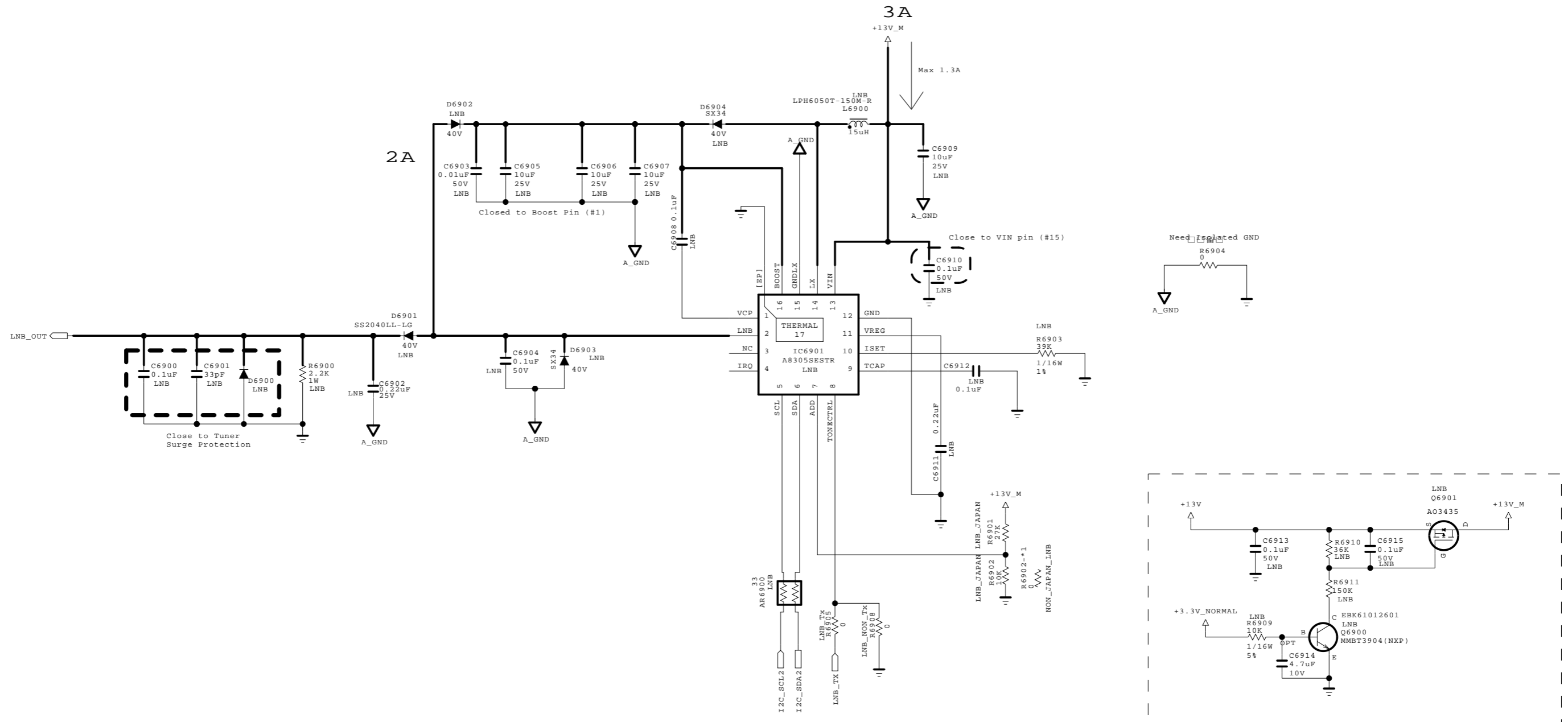

THE ⚠ SYMBOL MARK OF THIS SCHEMATIC DIAGRAM INCORPORATES SPECIAL FEATURES IMPORTANT FOR PROTECTION FROM X-RADIATION. FIRE AND ELECTRICAL SHOCK HAZARDS, WHEN SERVICING IF IS ESSENTIAL THAT ONLY MANUFACTURES SPECIFIED PARTS BE USED FOR THE CRITICAL COMPONENTS IN THE ⚠ SYMBOL MARK OF THE SCHEMATIC.

SECRET	
LGElectronics	

MODEL	K2H	DATE	2014-08-25
BLOCK	LNB	SHEET	20 /

[51P Vx1 output wafer]

LGD/BOE_PANEL_VX1
P7100
SP14-11592-01-51Pin

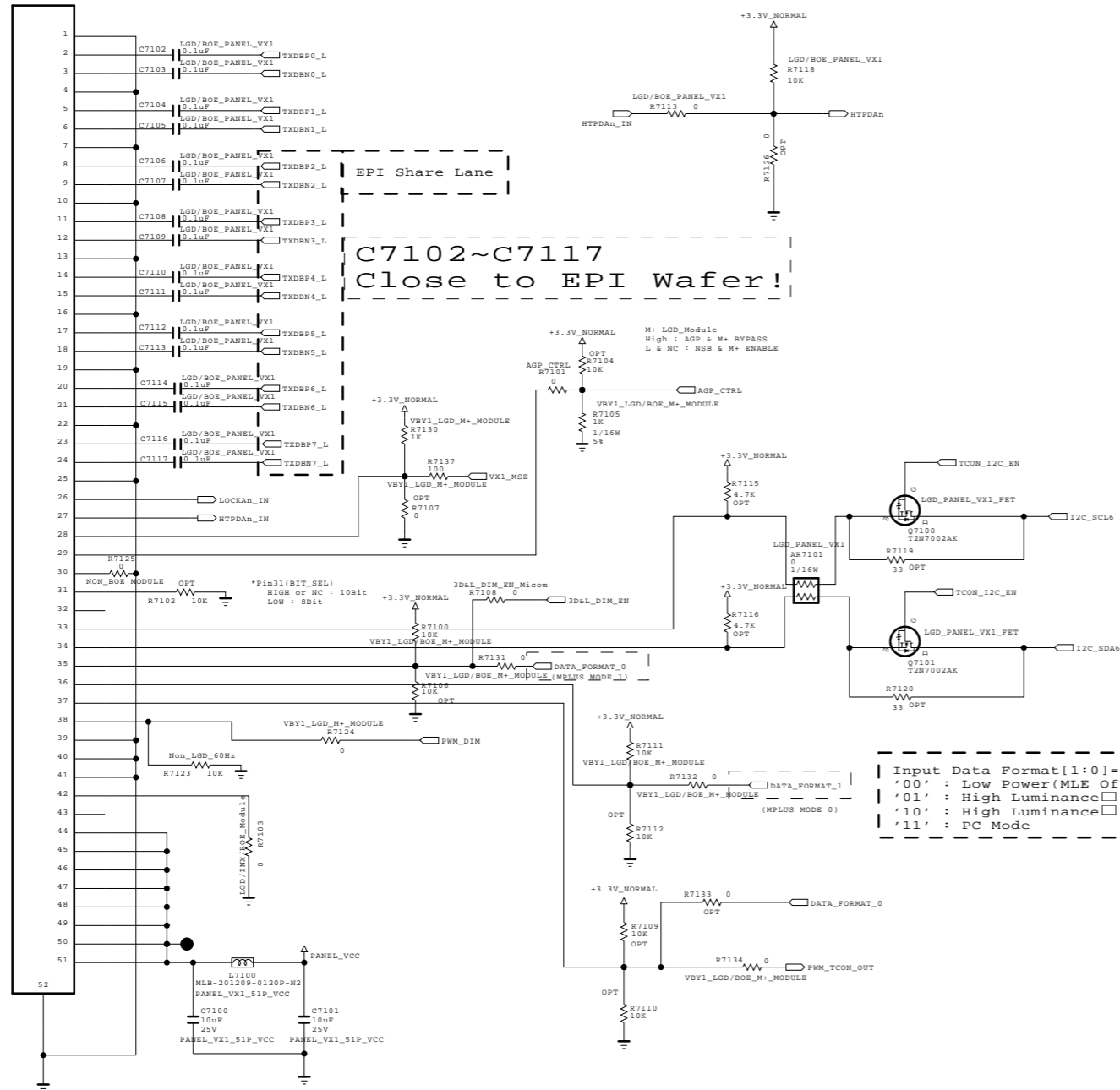

Input Data Format[1:0]=[35pin:36pin]
 '00' : Low Power (MLE Off)
 '01' : High Luminance (MLEB3)
 '10' : High Luminance (MLE1,2)
 '11' : PC Mode

Data Input Format[1:0]
 *Mode 1 (NON Division)
 - Data Format 0 (Pin37) = Low
 - Data Format 1 (Pin36) = Low
 *Mode 3 (4 Division)
 - Data Format 0 (Pin37) = Low
 - Data Format 1 (Pin36) = High

Must be assigned at Vx1 51p wafer !!!

SECRET
 LGElectronics



MODEL	K2H	DATE	2014-08-27
BLOCK	Vx1 51P	SHEET	21

eMMC I/F

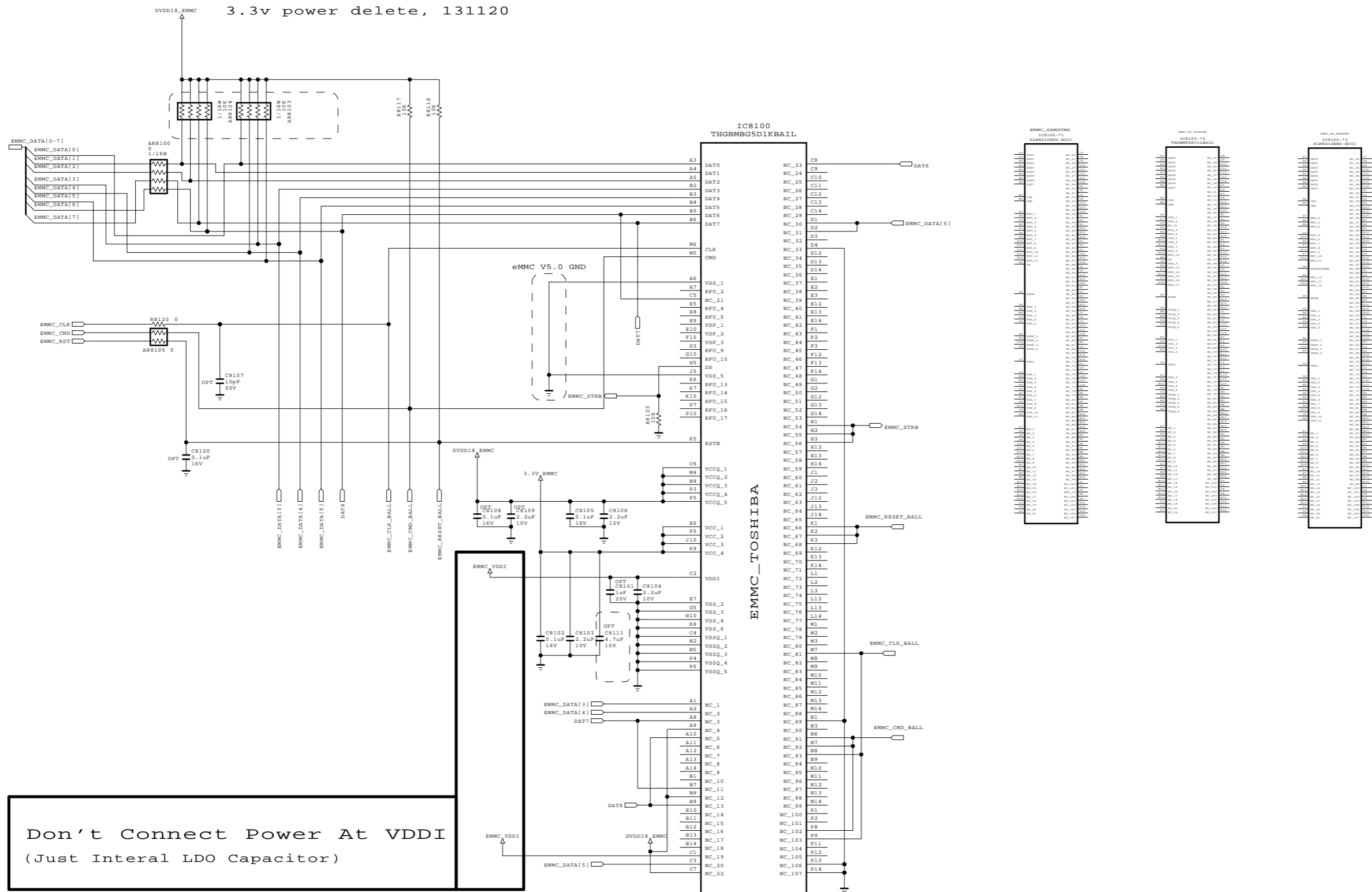

Don't Connect Power At VDD1
(Just Internal LDO Capacitor)

THE SYMBOL MARK OF THIS SCHEMATIC DIAGRAM INCORPORATES SPECIAL FEATURES IMPORTANT FOR PROTECTION FROM X-RADIATION. FIRE AND ELECTRICAL SHOCK HAZARDS, WHEN SERVICING IF IS ESSENTIAL THAT ONLY MANUFACTURERS SPECIFIED PARTS BE USED FOR THE CRITICAL COMPONENTS IN THE SYMBOL MARK OF THE SCHEMATIC.

SECRET
LGElectronics



MODEL	K2H	DATE	2014-11-17
BLOCK	eMMC	SHEET	81 /

RS-232C Control INTERFACE

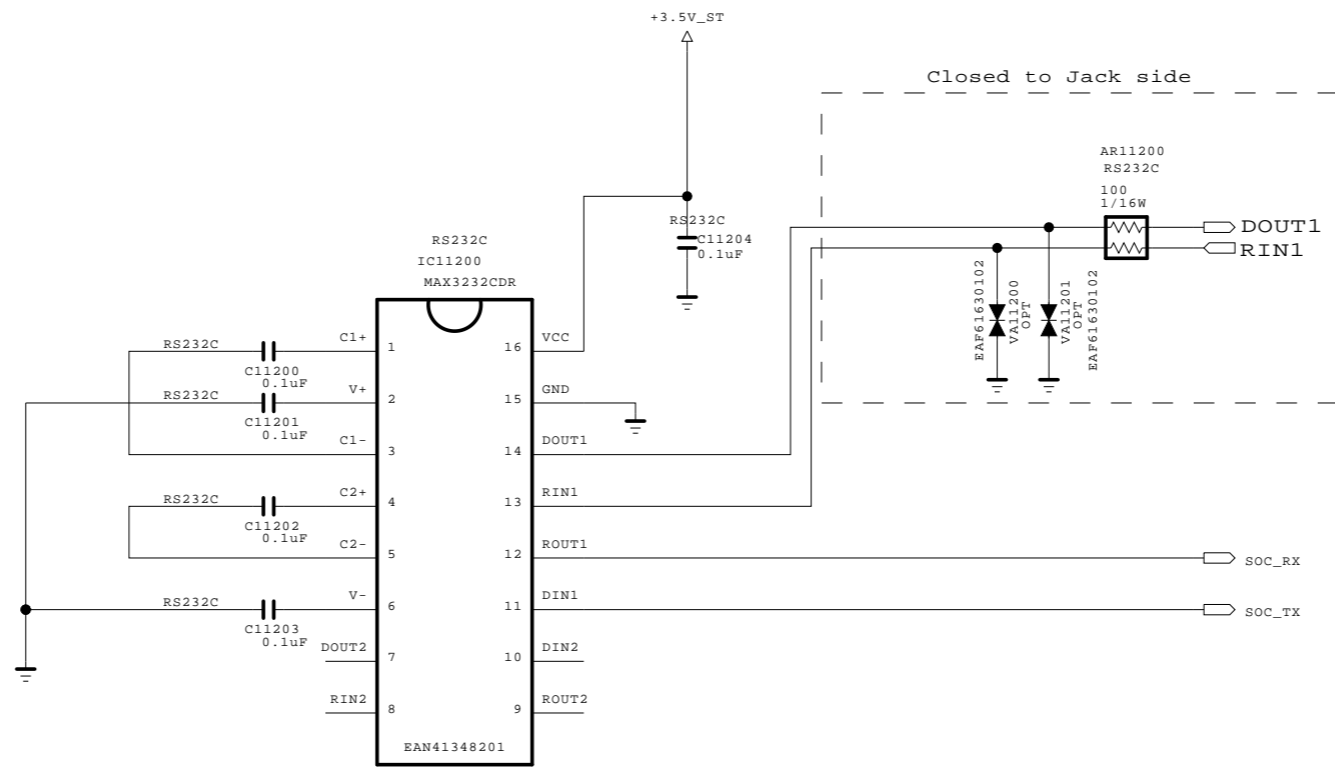

THE SYMBOL MARK OF THIS SCHEMATIC DIAGRAM INCORPORATES SPECIAL FEATURES IMPORTANT FOR PROTECTION FROM X-RADIATION. FIRE AND ELECTRICAL SHOCK HAZARDS, WHEN SERVICING IF IS ESSENTIAL THAT ONLY MANUFACTURERS SPECIFIED PARTS BE USED FOR THE CRITICAL COMPONENTS IN THE SYMBOL MARK OF THE SCHEMATIC.

SECRET
LGElectronics



MODEL	UF71/7500	DATE	2014-05-19
BLOCK	RS232C	SHEET	22 /



TROUBLE SHOOTING GUIDE

Contents of Standard Repair Process

No.	Error symptom (High category)	Error symptom (Mid category)	Page	Remarks
1	A. Video error	No video/Normal audio	1	
2		No video/No audio	2	
3		Picture broken/ Freezing	3	
4		Color error	4	
5		Vertical/Horizontal bar, residual image, light spot, external device color error	5	
6	B. Power error	No power	6	
7		Off when on, off while viewing, power auto on/off	7	
8	C. Audio error	No audio/Normal video	8	
9		Wrecked audio/discontinuation/noise	9	
10	D. Function error	Remote control & Local switch checking	10	
11		MR15 operating checking	11	Not used
12		Wifi operating checking	12	
13		Camera operating checking	13	Not used
14		External device recognition error	14	
15	E. Noise	Circuit noise, mechanical noise	15	
16	F. Exterior error	Exterior defect	16	

First of all, Check whether there is SVC Bulletin in GSCS System for these model.

**Overview for '16 ULTRA HD Model
K2Lp
(Hardware)**

'16 ULTRA HD New Feature 1. HDMI

- All HDMI ports support ULTRA HD Deep Color.

Classification	HDMI1.4	HDMI2.0 3Gbps	HDMI2.0 6Gbps 4K@60Hz 4:2:2 10bit	HDCP2.2	ARC	MHL	HDMI1.4 Legacy
HDMI 3	○	○	○	○	X	X	○
HDMI 2	○	○	○	○	○	X	○
HDMI 1	○	○	○	○	X	X	○

- If the device connected to Input Port also supports ULTRA HD Deep Color, your picture may be Clearer.

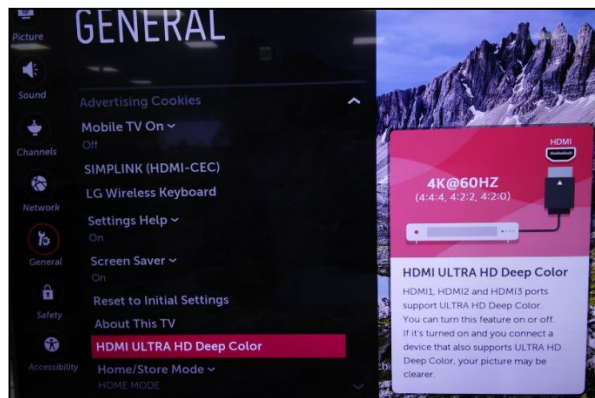

- Home > Settings > General > HDMI ULTRA HD Deep Color:
 - On : Support 4K @ 60 Hz (4:4:4, 4:2:2, 4:2:0)
 - Off : Support 4K @ 60 Hz (4:2:0)

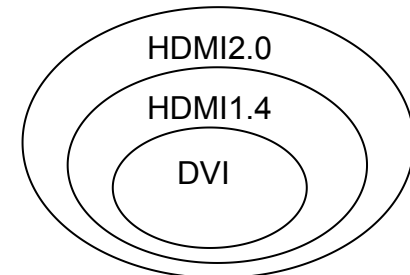

LCD TV Repair Guide

`16 years New Models

< Applicable Model >

UH55

Main PCB(210X183)

UH55

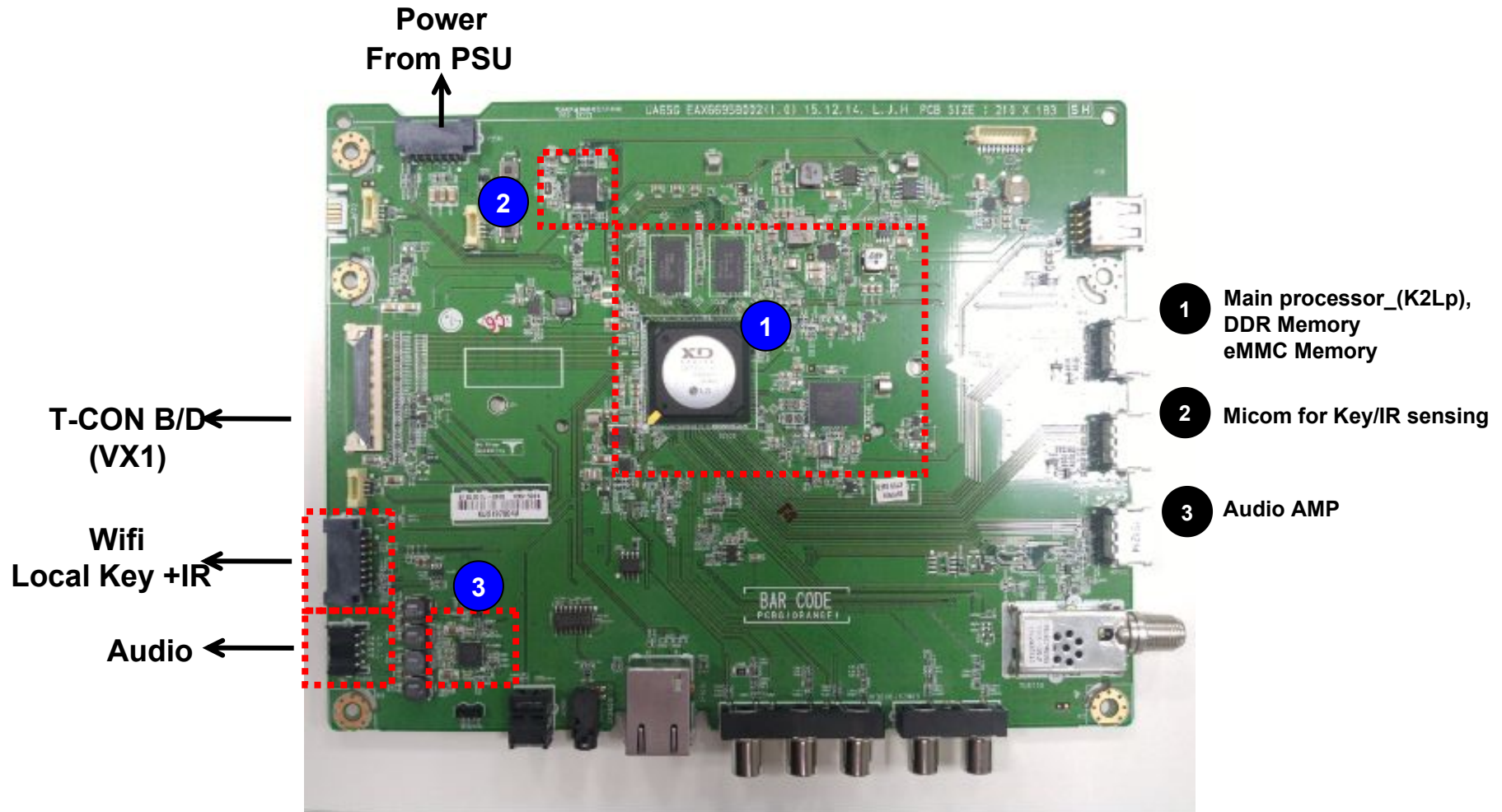

`16Y ULTRA HD Block Diagram

Contents

0. **System Overview (Main External)**
1. **K2Lp Block Diagram (External)**
2. **K2Lp Block Diagram (Internal)**
3. **K2Lp I2C Diagram**
4. **K2Lp Power Block Diagram**
5. **Tuner/CI Block Diagram**
6. **Video/Audio In Block Diagram**
7. **Audio Out Block Diagram**
8. **HDMI**
9. **USB / WIFI / UART**
10. **WOL**

2015.12.22

TV Product Development Team 1

0. System Overview (Main External)

- ONLY 60HZ(T120) Model

<15 year UHD model>

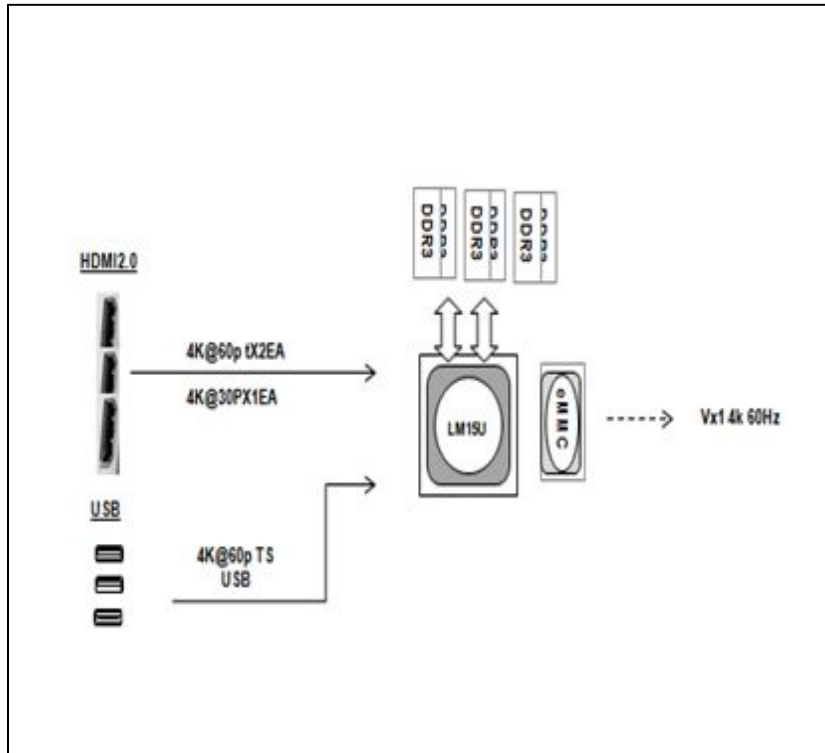

<16 year UHD model>

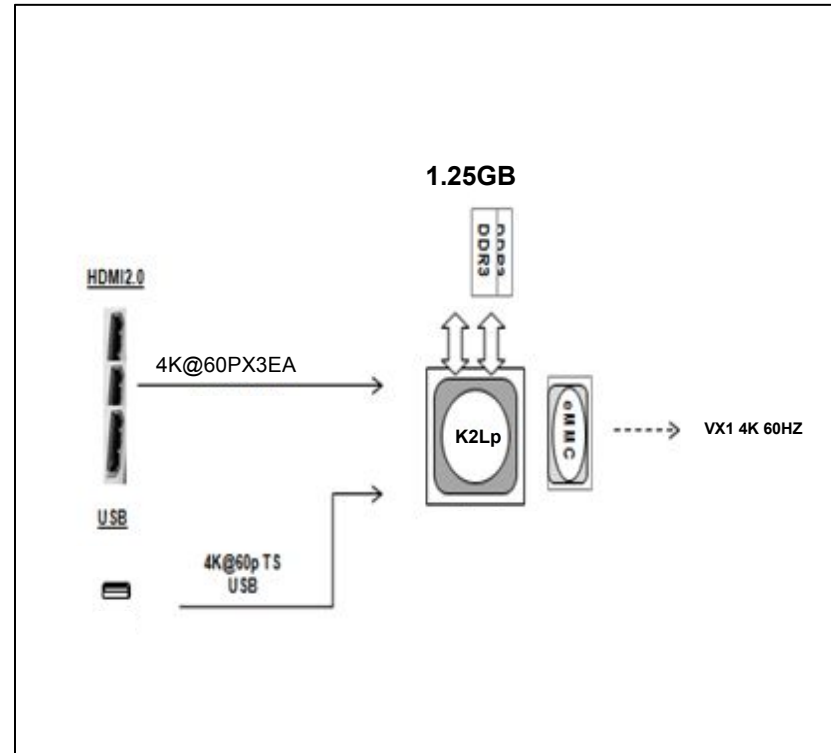

1. K2Lp Circuit Block Diagram

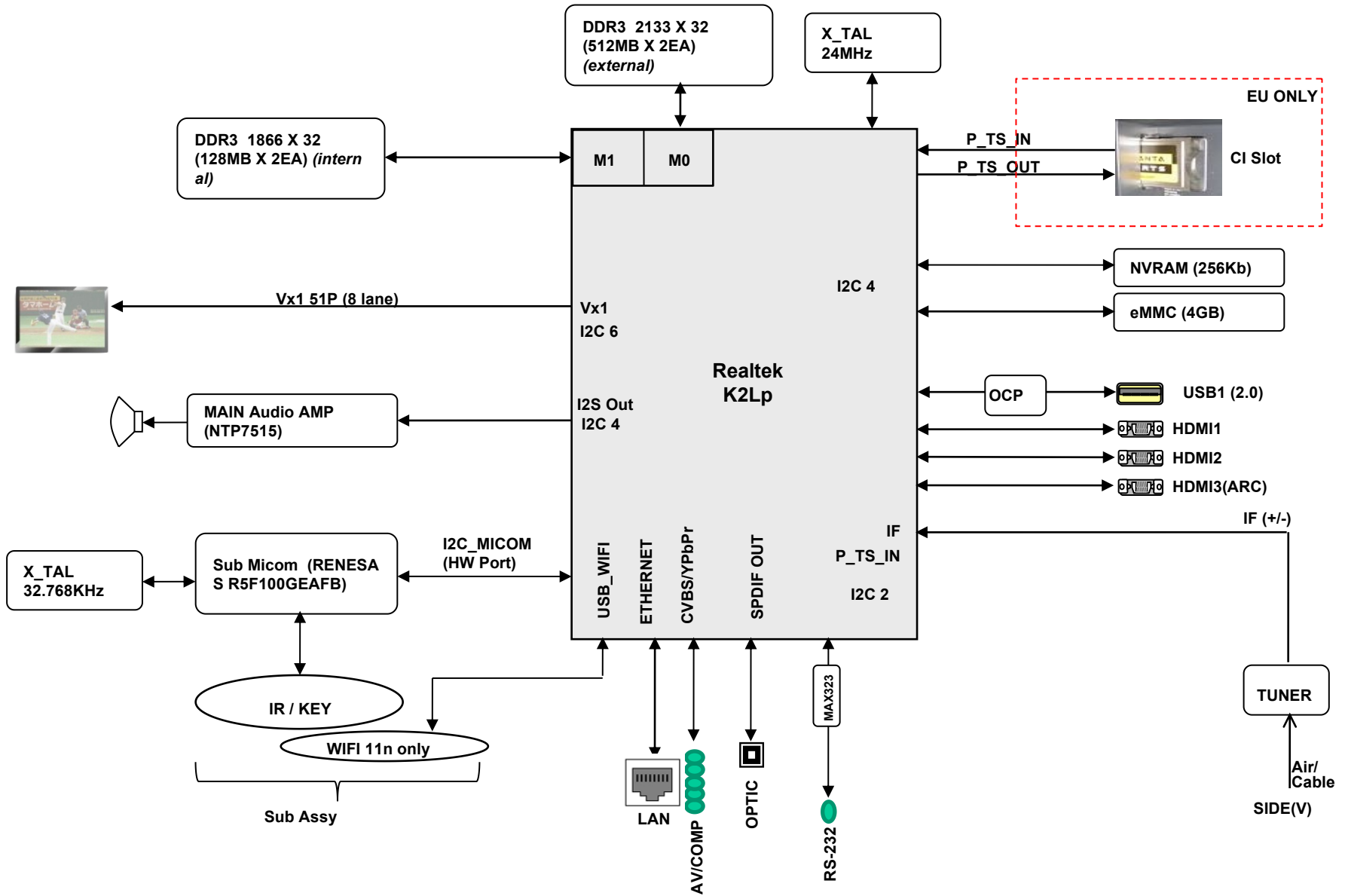

LGE Confidential

2. K2Lp Block Diagram (Internal)

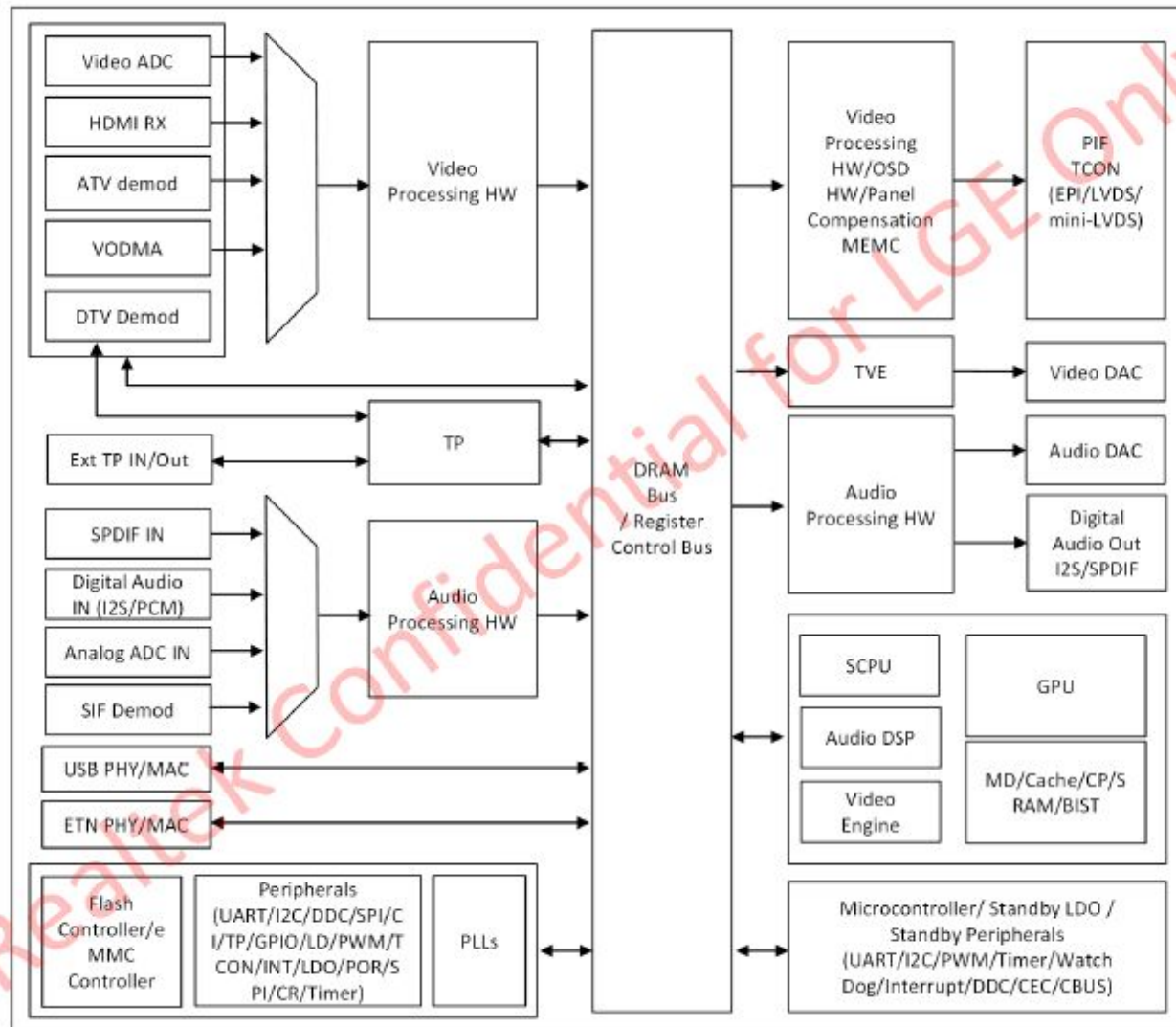

3. K2Lp I2C Block Diagram

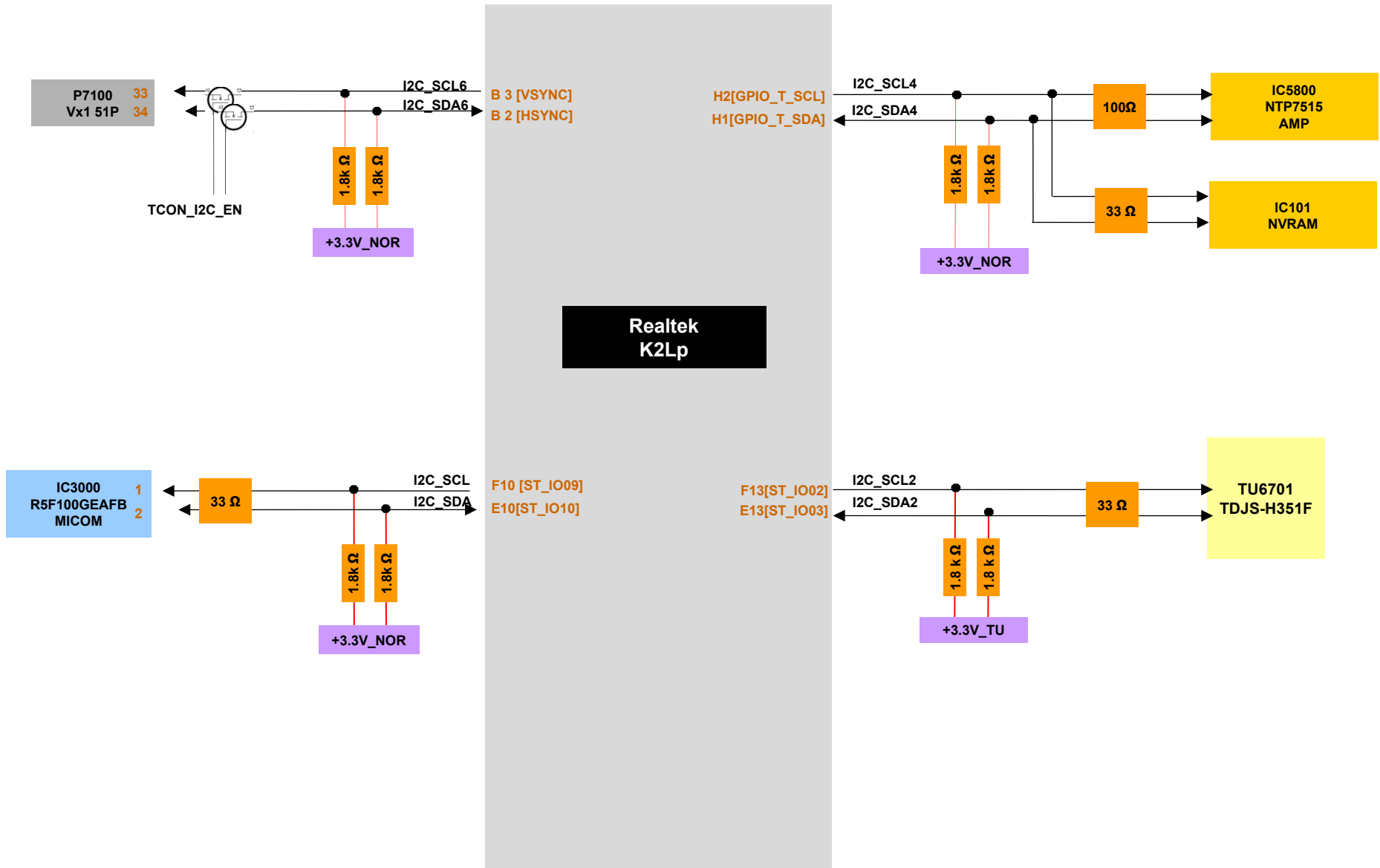

LGE Confidential

4. K2Lp Power Block Diagram

[UH55 Main]

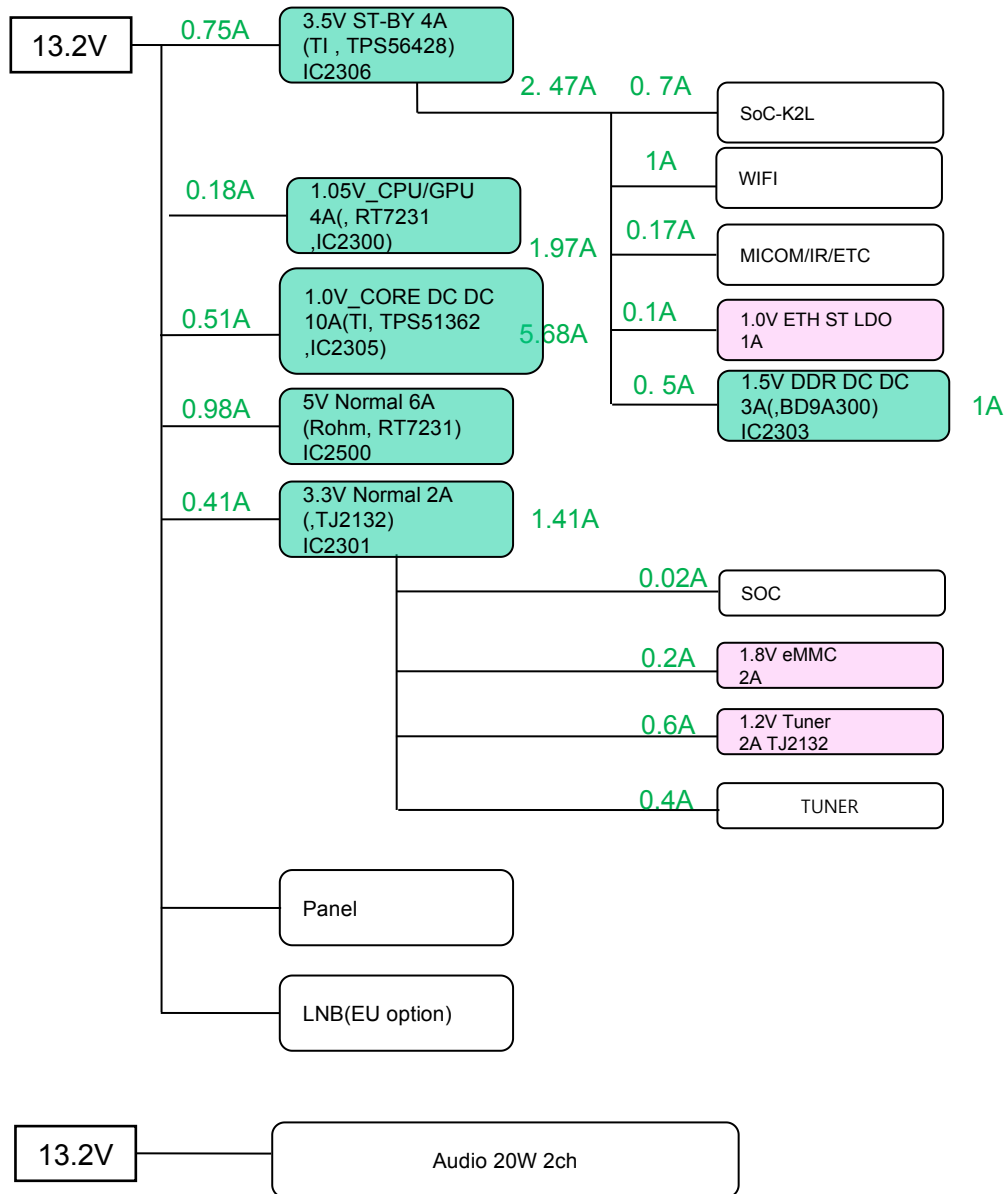

5. Tuner/CI Block Diagram

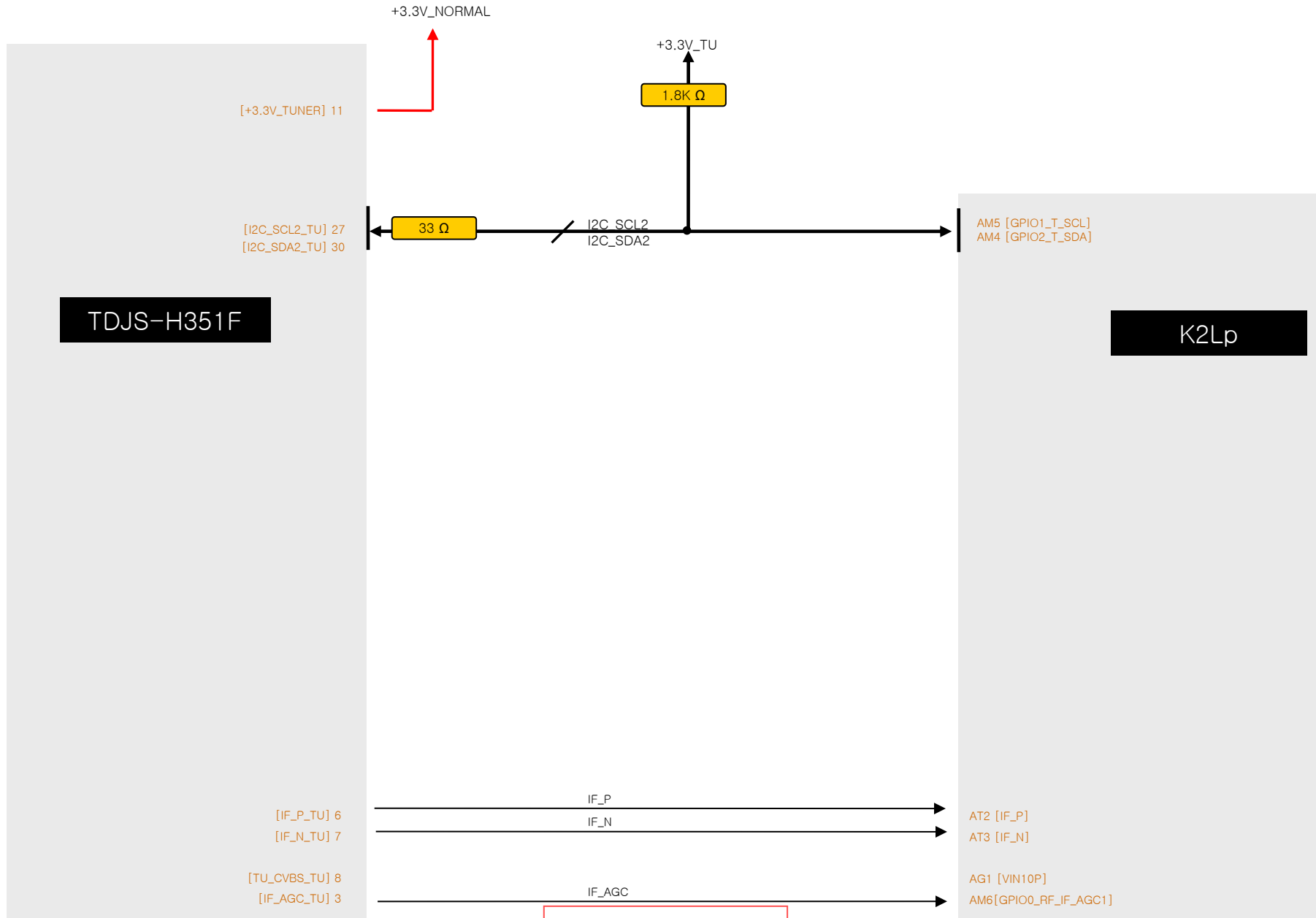

LGE Confidential

6. Video/Audio In Block Diagram

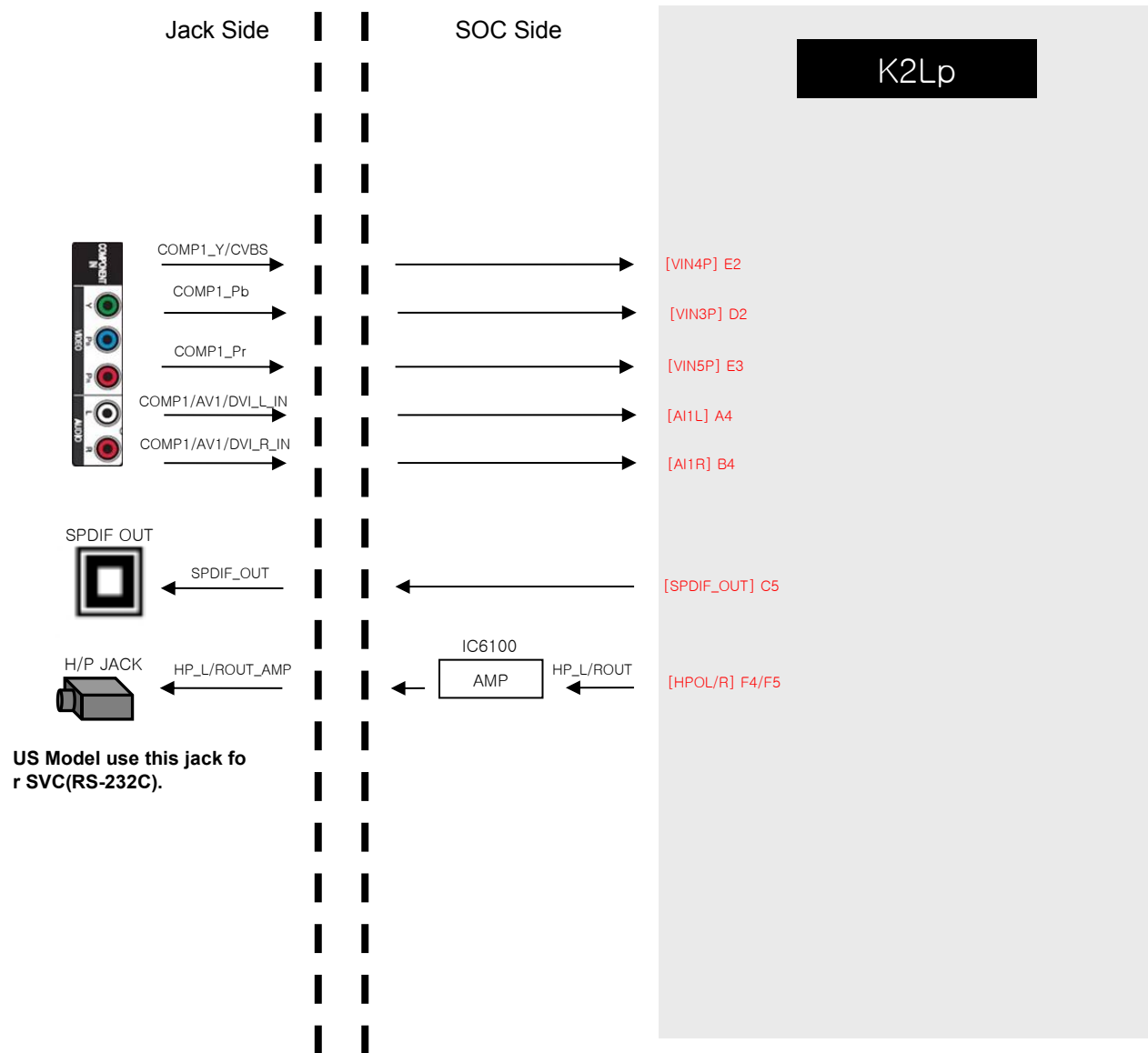

7. Audio Out Block Diagram

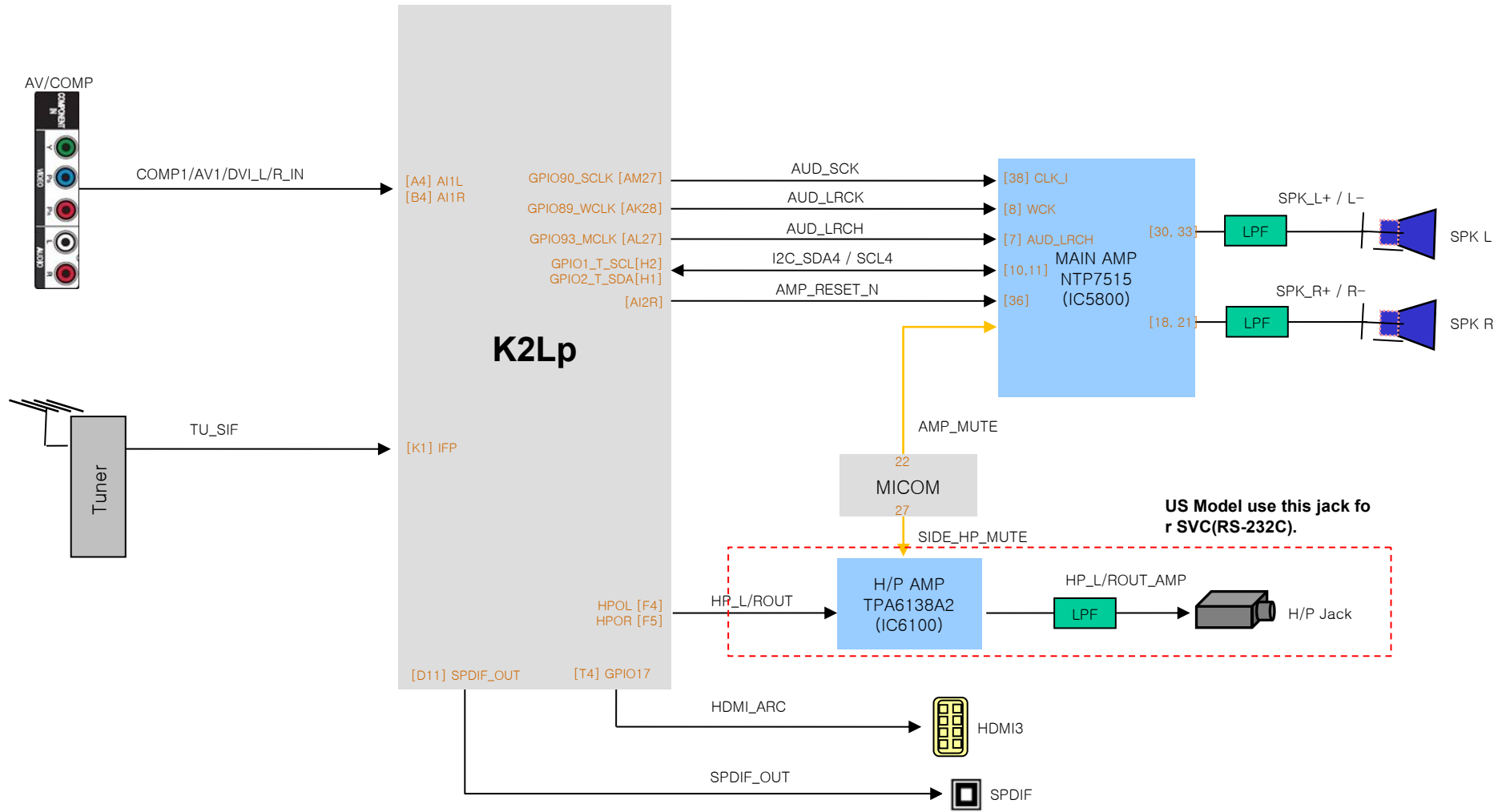

LGE Confidential

8. HDMI

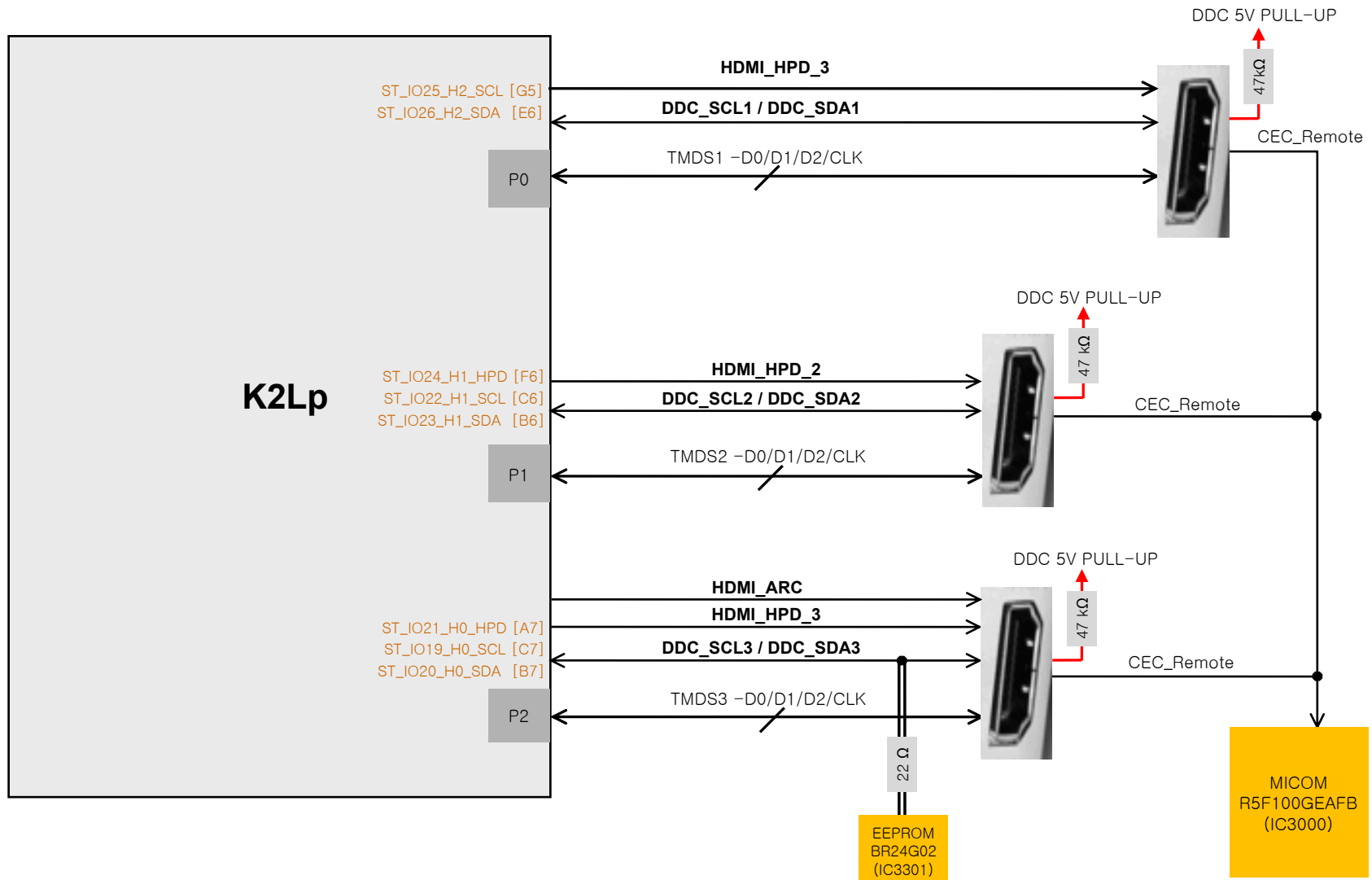

KOREA Model only support External. EEPROM

LGE Confidential

9. USB / WIFI / UART

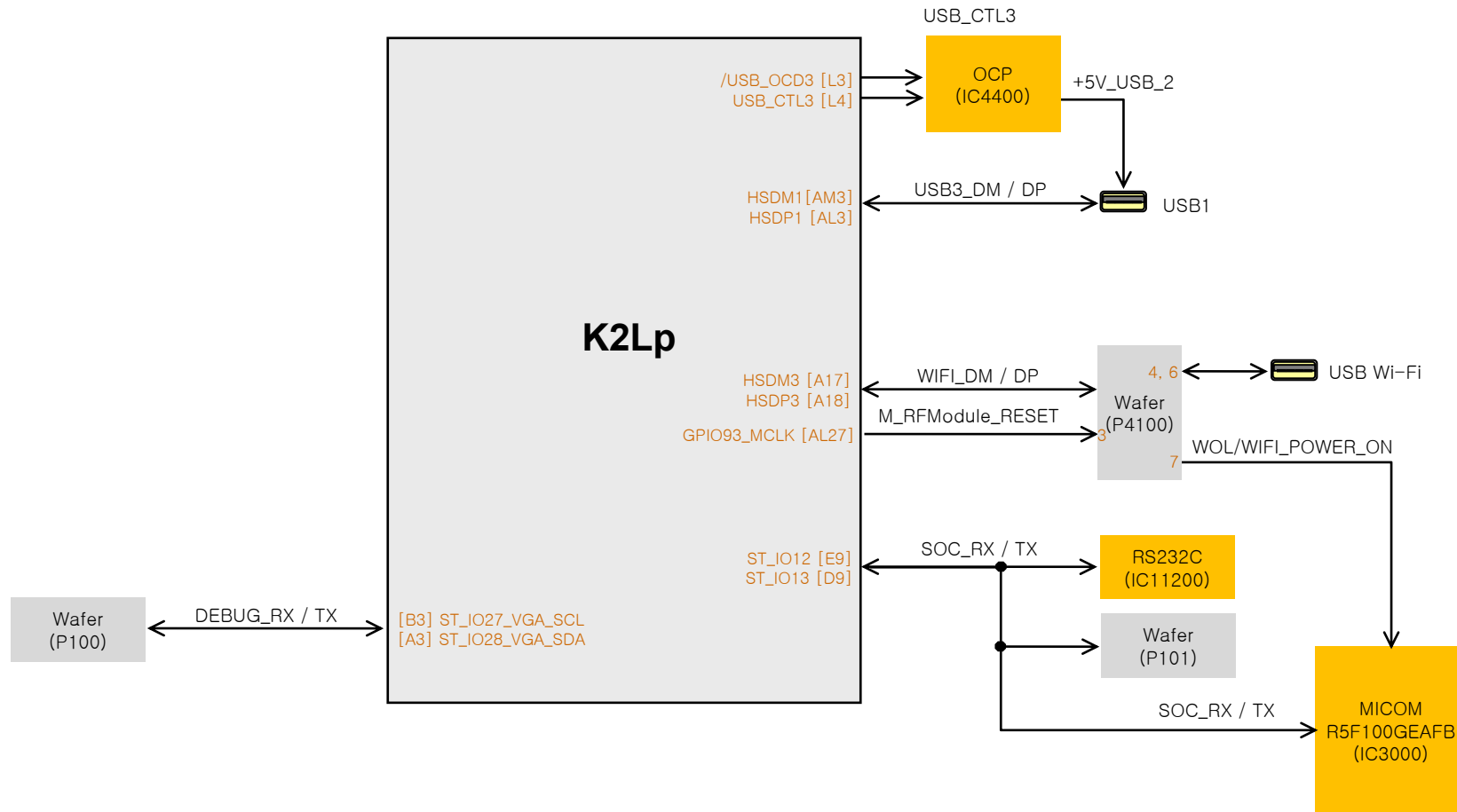

10. WOL

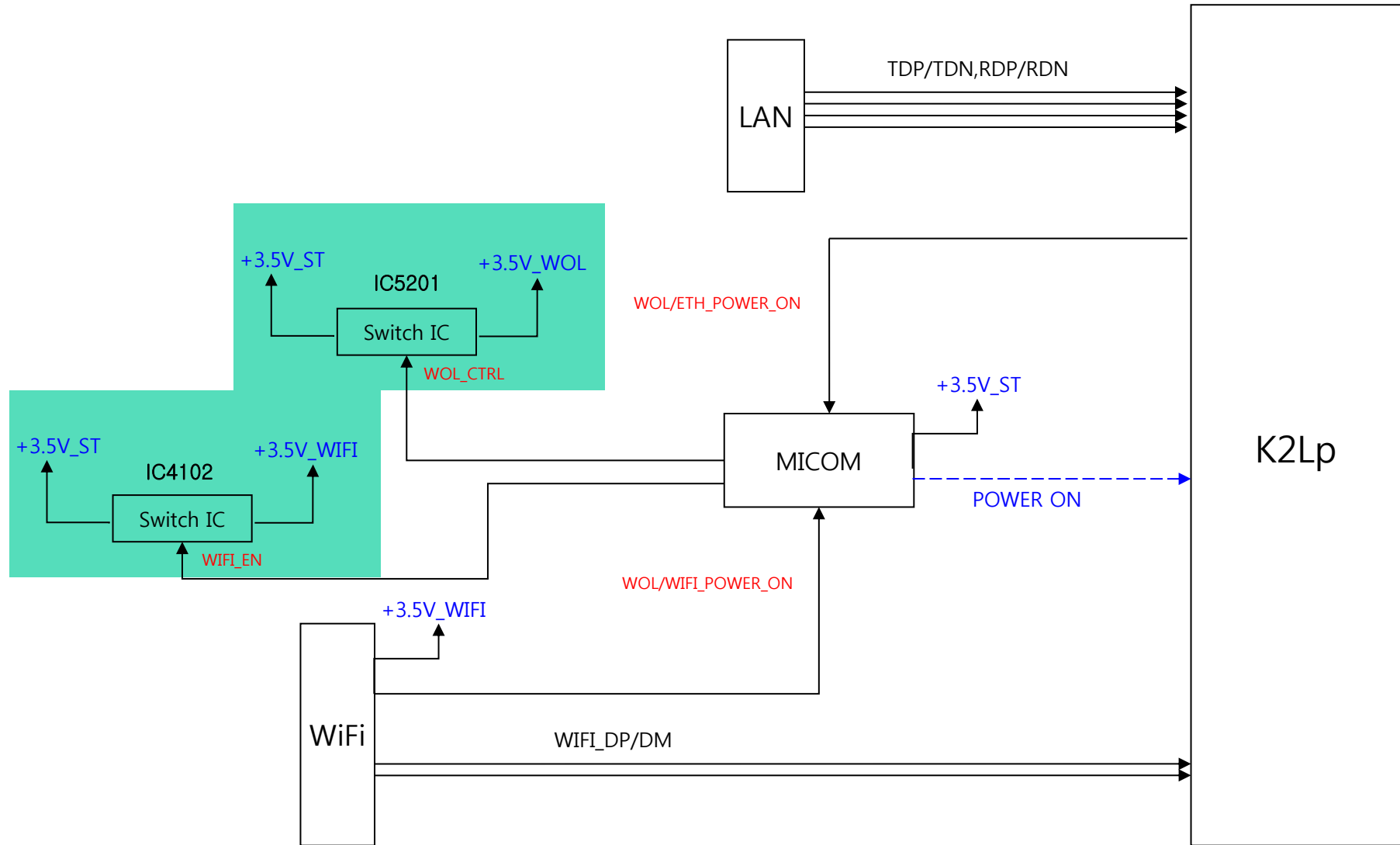

TROUBLE SHOOTING GUIDE

Contents of Standard Repair Process

No.	Error symptom (High category)	Error symptom (Mid category)	Page	Remarks
1	A. Video error	No video/Normal audio	1	
2		No video/No audio	2	
3		Picture broken/ Freezing	3	
4		Color error	4	
5		Vertical/Horizontal bar, residual image, light spot, external device color error	5	
6	B. Power error	No power	6	
7		Off when on, off while viewing, power auto on/off	7	
8	C. Audio error	No audio/Normal video	8	
9		Wrecked audio/discontinuation/noise	9	
10	D. Function error	Remote control & Local switch checking	10	
11		MR15 operating checking	11	Not used
12		Wifi operating checking	12	
13		Camera operating checking	13	Not used
14		External device recognition error	14	
15		E. Noise	Circuit noise, mechanical noise	15
16	F. Exterior error	Exterior defect	16	

First of all, Check whether there is SVC Bulletin in GSCS System for these model.

Standard Repair Process

LCD TV	Error symptom	A. Video error	Established date	
		No video/ Normal audio	Revised date	1/16

**First of all, Check whether all of cables between board is inserted properly or not.
(Main B/D↔ Power B/D, VX1 Cable, Speaker Cable, IR B/D Cable,,)**

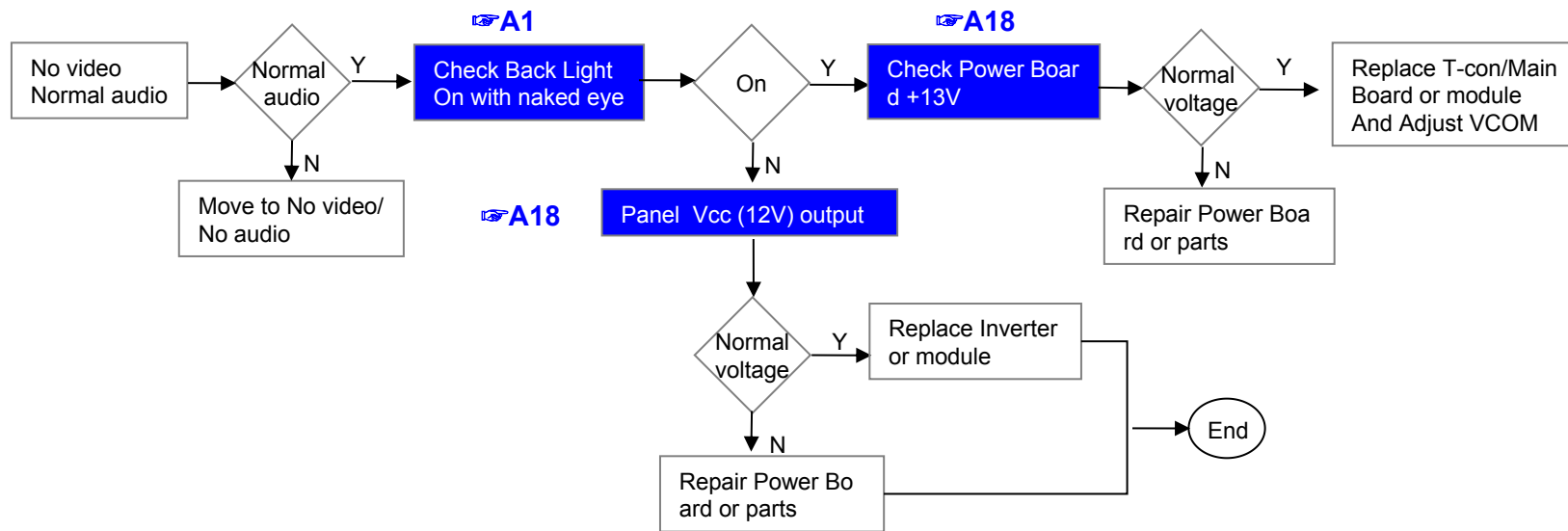

※Precaution A4 & A2



Standard Repair Process

	Error symptom	A. Video error	Established date		
		No video/ No audio	Revised date		2/16

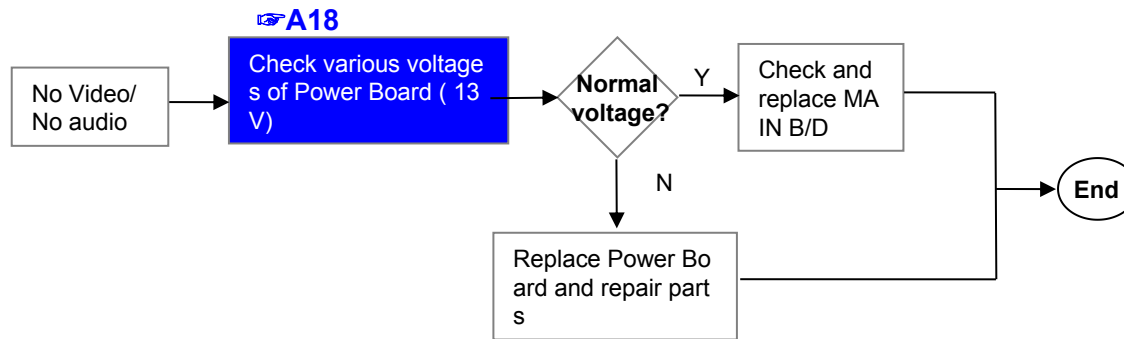

Standard Repair Process

	Error symptom	A. Video error	Established date		
		Picture broken/ Freezing	Revised date		3/16

A3

Check RF Signal level

- . By using Digital signal level meter
- . By using Diagnostics menu on OSD
(All Settings→ Channels→ Channel Tuning→ Manual Tuning → Signal Strength, Signal Quality)
- Signal strength (Normal : over 50%)
- Signal Quality (Normal: over 50%)

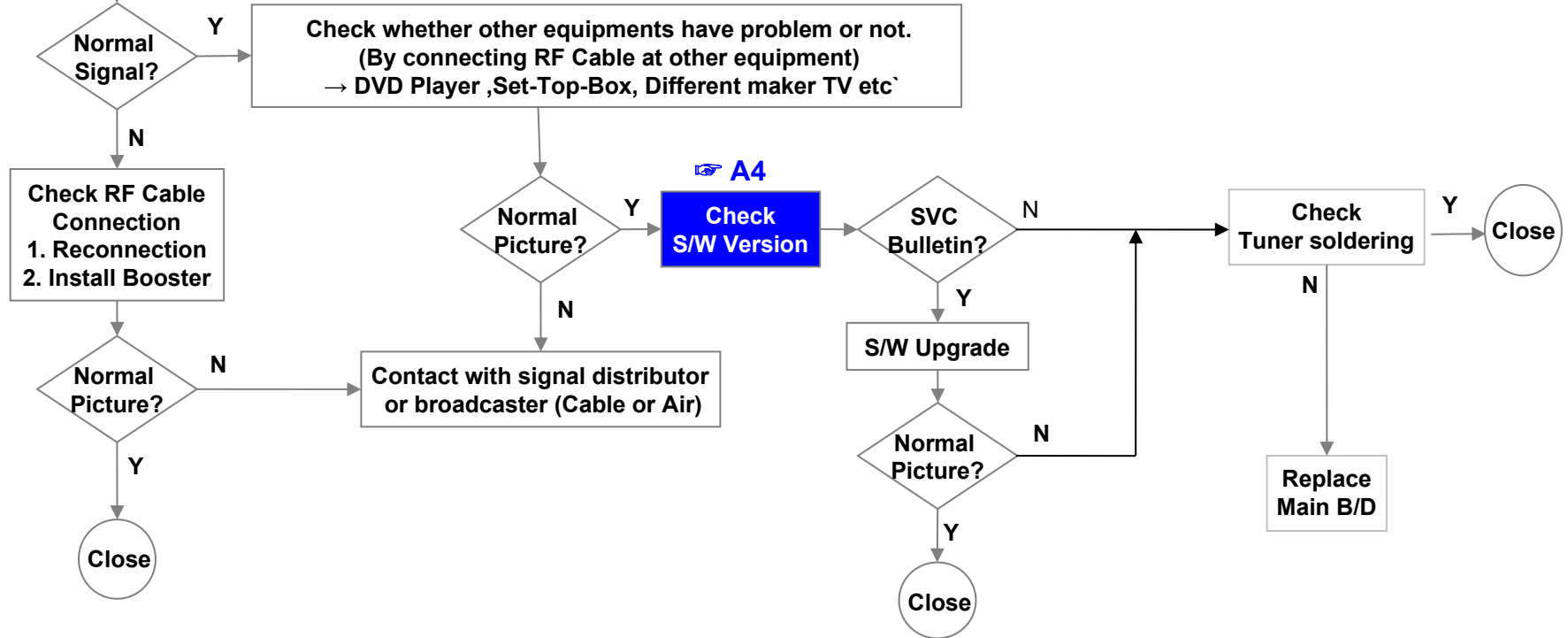

Standard Repair Process

Error symptom	A. Video error	Established date	
	Color error	Revised date	4/16

A6

Check color by input
-External Input
-COMPONENT
-AV
-HDMI

A7

※ Check and replace Link Cable (V by one) and contact condition

A8

Check Test pattern

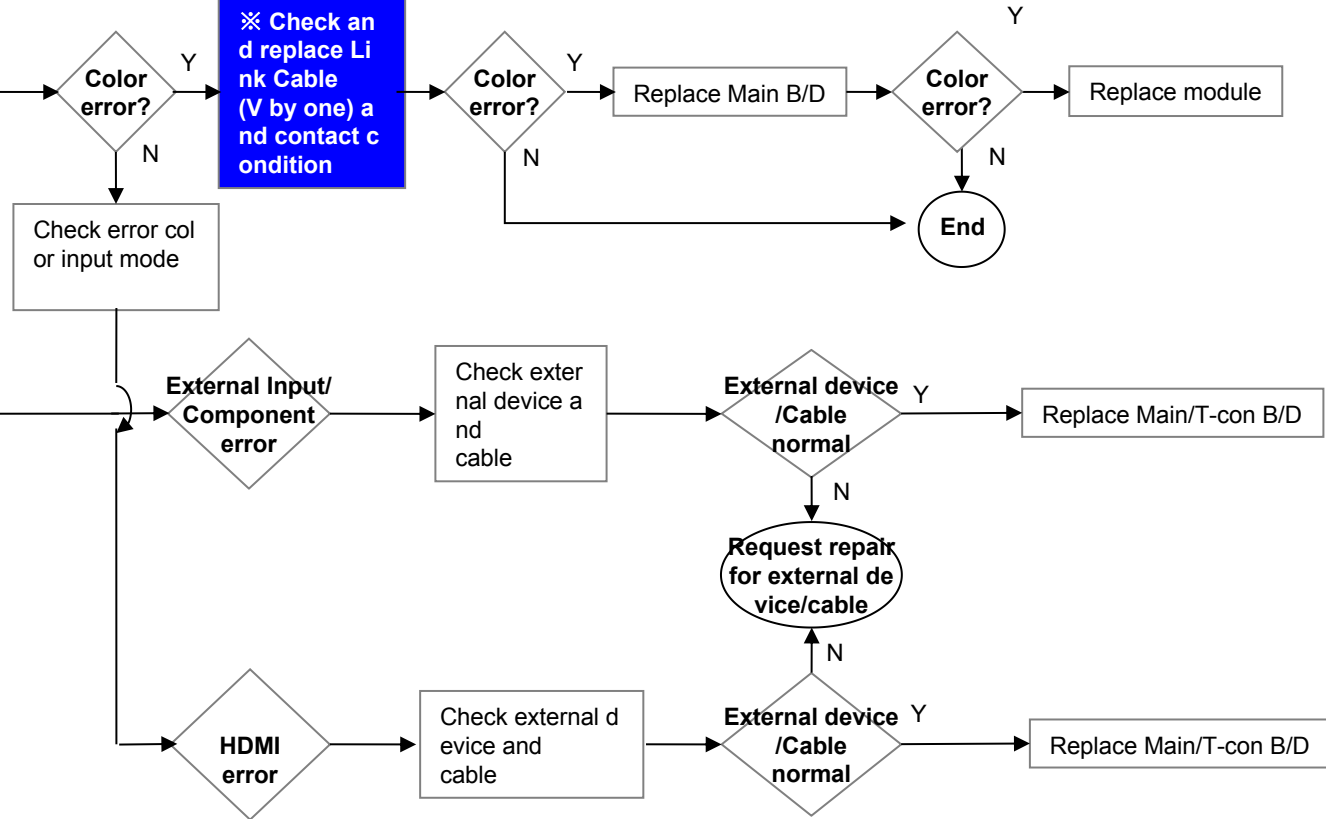

Standard Repair Process

	Error symptom	A. Video error	Established date	
		Vertical / Horizontal bar, residual image, light spot, external device color error	Revised date	5/16

Vertical/Horizontal bar, residual image, light spot

A6

Check color condition by input
-External Input
-Component
-HDMI

Screen normal?

Check external device connection condition

Normal?

A7

Check and replace Link Cable

Screen normal?

For LGD panel

For other panel

Replace Module

Replace Main/T-con B/D (adjust VCOM)

Replace Main B/D

End

A8

Check Test pattern

Replace module

Request repair for external device

End

End

External device screen error-Color error

Check S/W Version

Check version

S/W Upgrade

Normal screen?

End

Check screen condition by input
-External Input
-Component
-HDMI

External Input error

Component error

HDMI/DVI

Connect other external device and cable
(Check normal operation of External Input, Component, and HDMI by connecting Jig, pattern Generator, Set-top Box etc.)

Connect other external device and cable
(Check normal operation of External Input, Component, and HDMI by connecting Jig, pattern Generator, Set-top Box etc.)

Screen normal?

Request repair for external device

Screen normal?

Replace Main/T-con B/D

Replace Main /T-con B/D

Standard Repair Process

	Error symptom	B. Power error	Established date		
		No power	Revised date		6/16

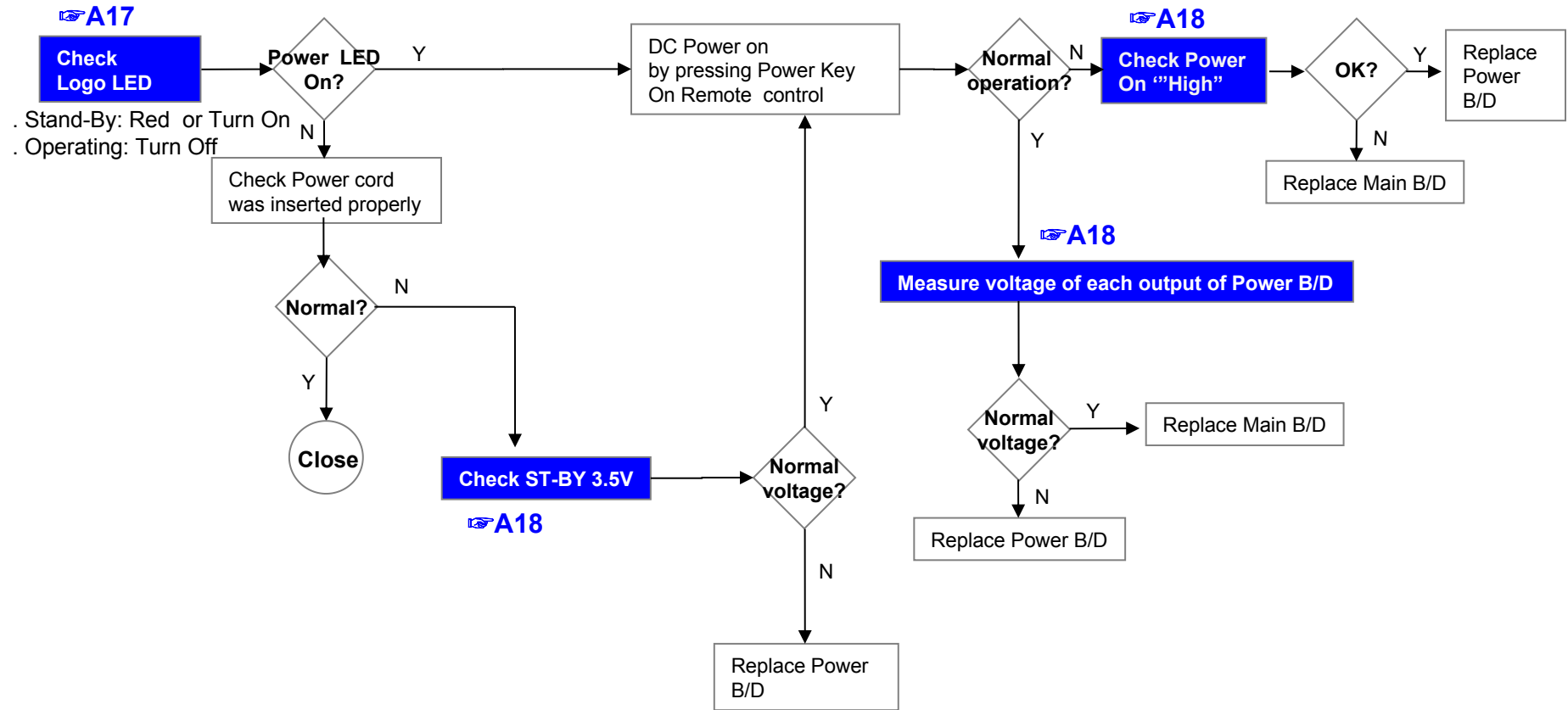

Standard Repair Process

	Error symptom	B. Power error	Established date	
		Off when on, off while viewing, power auto on/off	Revised date	7/16

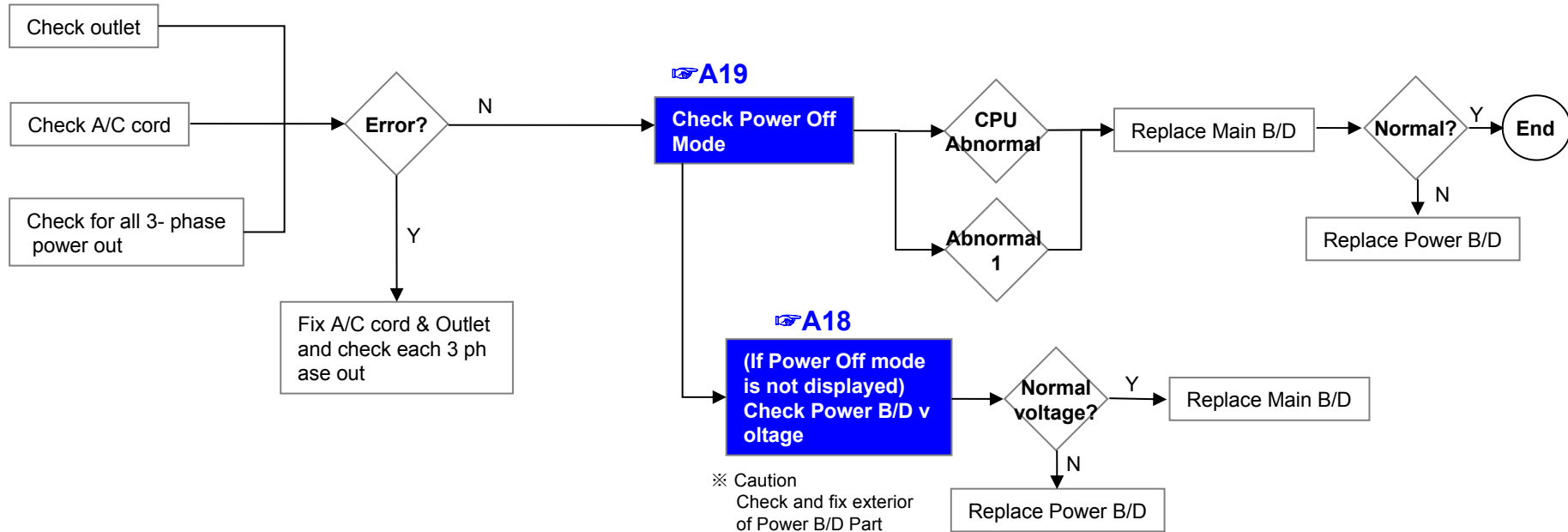

* Please refer to the all cases which can be displayed on power off mode.

Status	Power off List	Explanation
Normal	"POWEROFF_Remote KEY"	Power off by Remote CONTROL
	"POWEROFF_OFFTIMER"	Power off by OFF TIMER
	"POWEROFF_SLEEPTIMER"	Power off by SLEEP TIMER
	"POWEROFF_INSTOP"	Power off by INSTOP KEY
	"POWEROFF_AUTOOFF"	Power off by AUTO OFF
	"POWEROFF_ONTIMER"	Power off by ON TIMER
	"POWEROFF_RS232C"	Power off by RS232C
	"POWEROFF_RESREC"	Power off by Reserved Record
	"POWEROFF_RECEND"	Power off by End of Recording
	"POWEROFF_SWDOWN"	Power off by S/W Download
	"POWEROFF_UNKNOWN"	Power off by unknown status except listed case
Abnormal	"POWEROFF_ABNORMAL1"	Power off by abnormal status except CPU trouble
	"POWEROFF_CPUABNORMAL"	Power off by CPU Abnormal

Standard Repair Process

	Error symptom	C. Audio error	Established date		
		No audio/ Normal video	Revised date		8/16

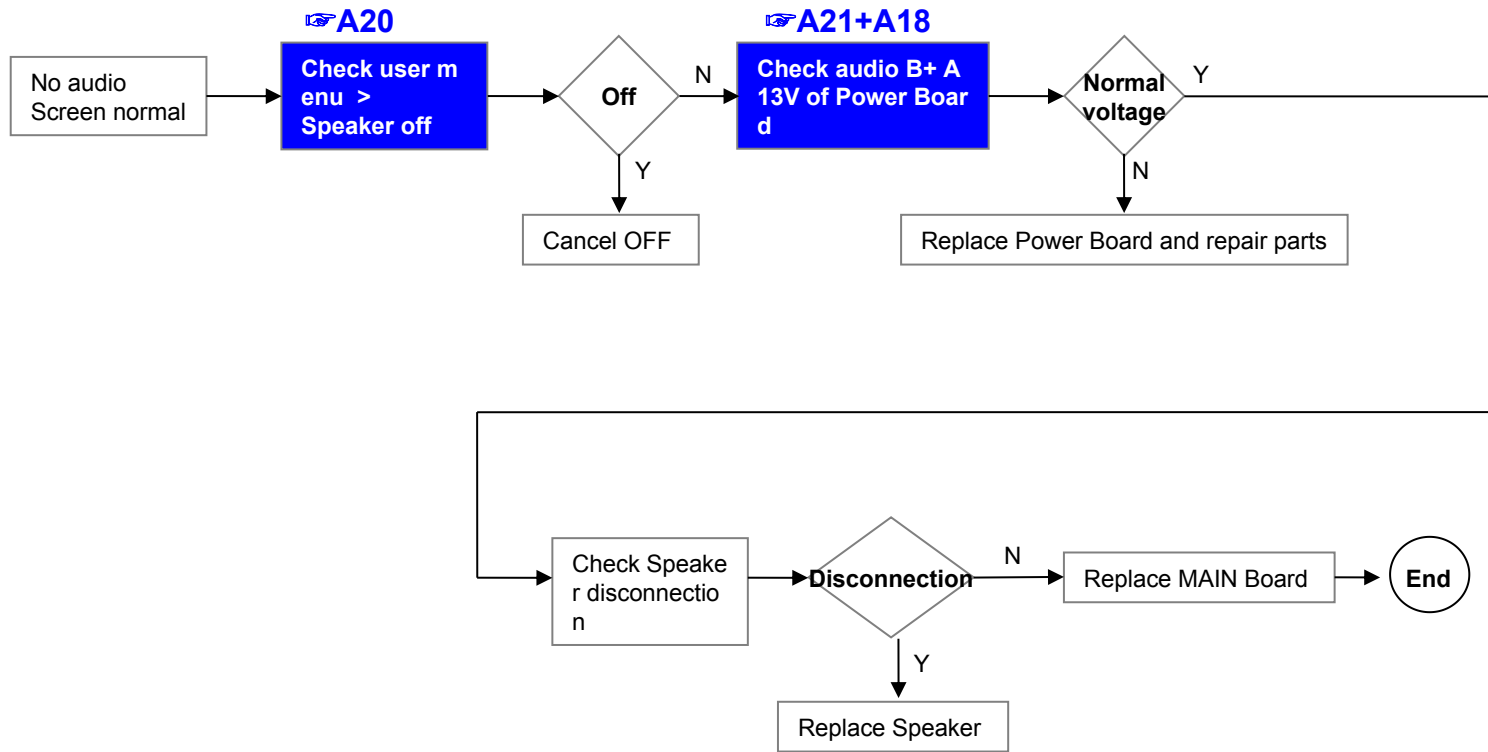

Standard Repair Process

	Error symptom	C. Audio error	Established date	
		Wrecked audio/ discontinuation/noise	Revised date	9/16

→ abnormal audio/discontinuation/noise is same after "Check input signal" compared to No audio

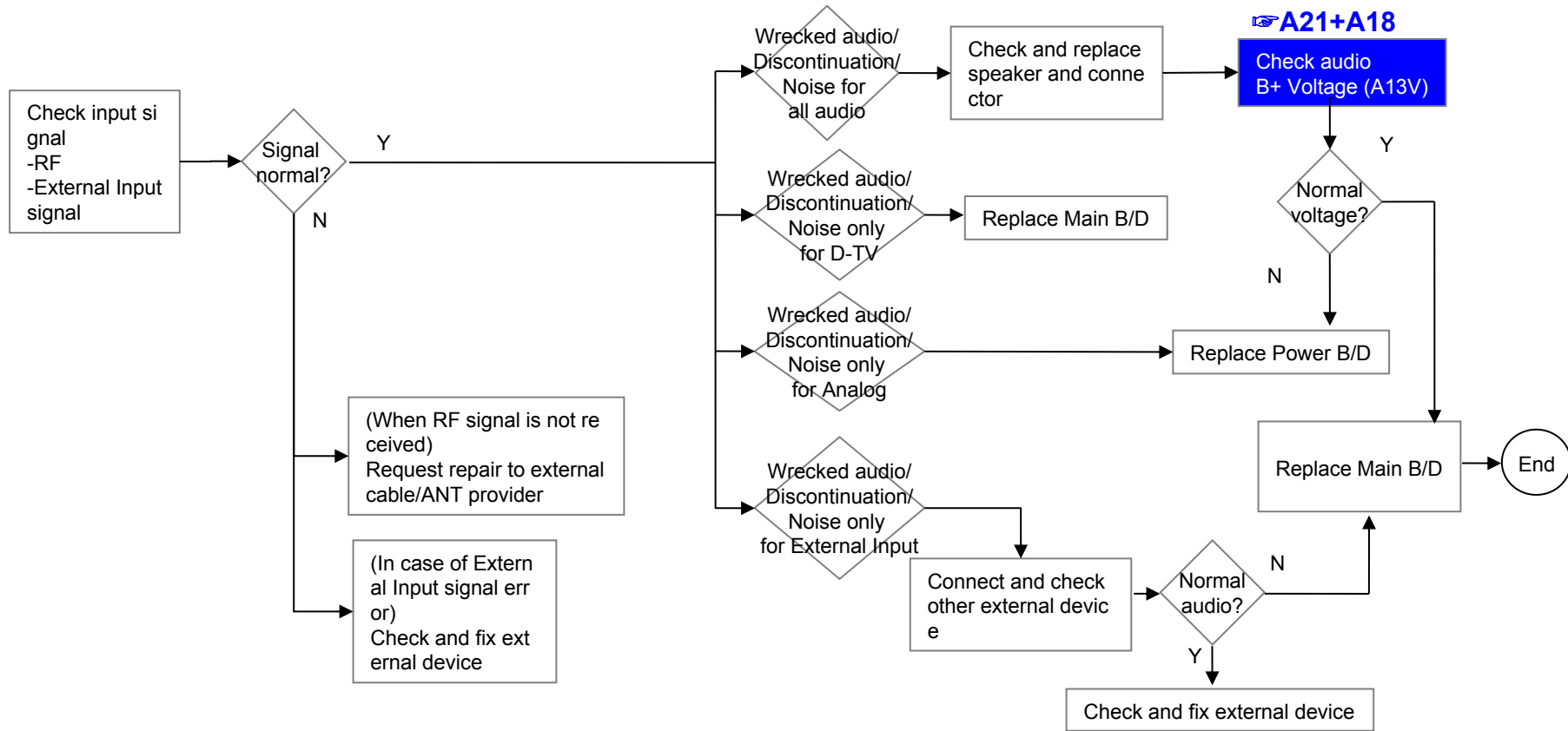

Standard Repair Process

	Error symptom	D. Function error	Established date		
		Remote control & Local switch checking	Revised date		10/16

1. Remote control(R/C) operating error

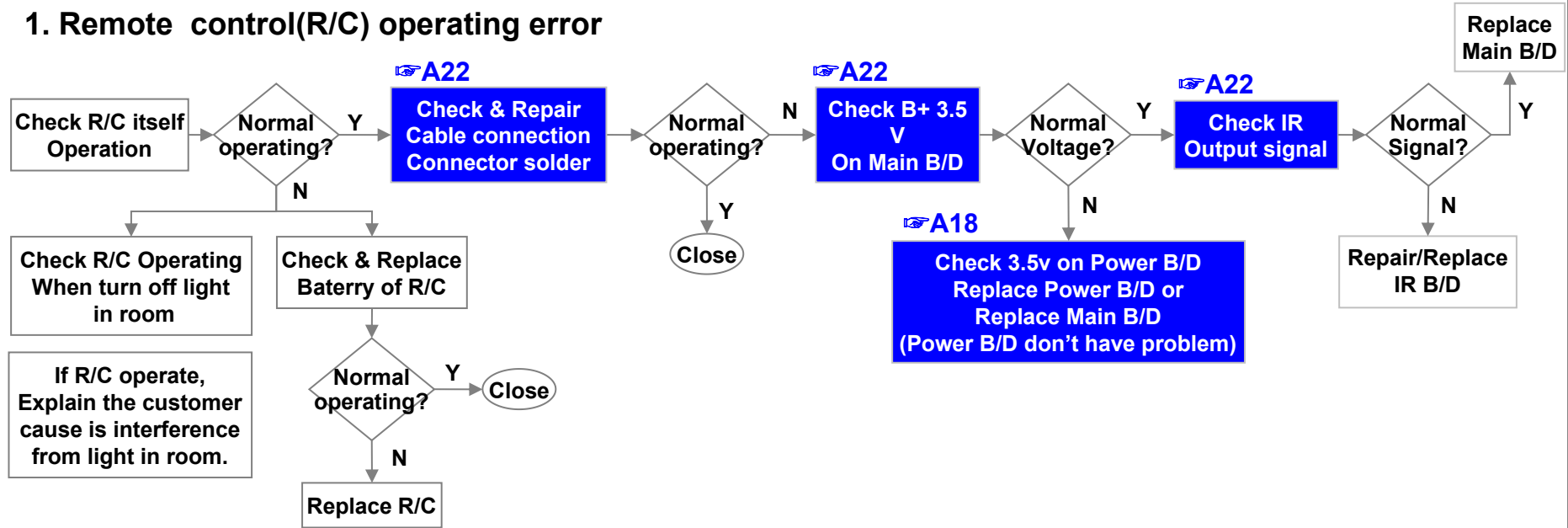

	Error symptom	D. Function error	Established date		
		MR13 operating checking	Revised date		11/16

2. MR15(Magic Remocon) operating error (UH55 Model doesn't support Magic Remocon)

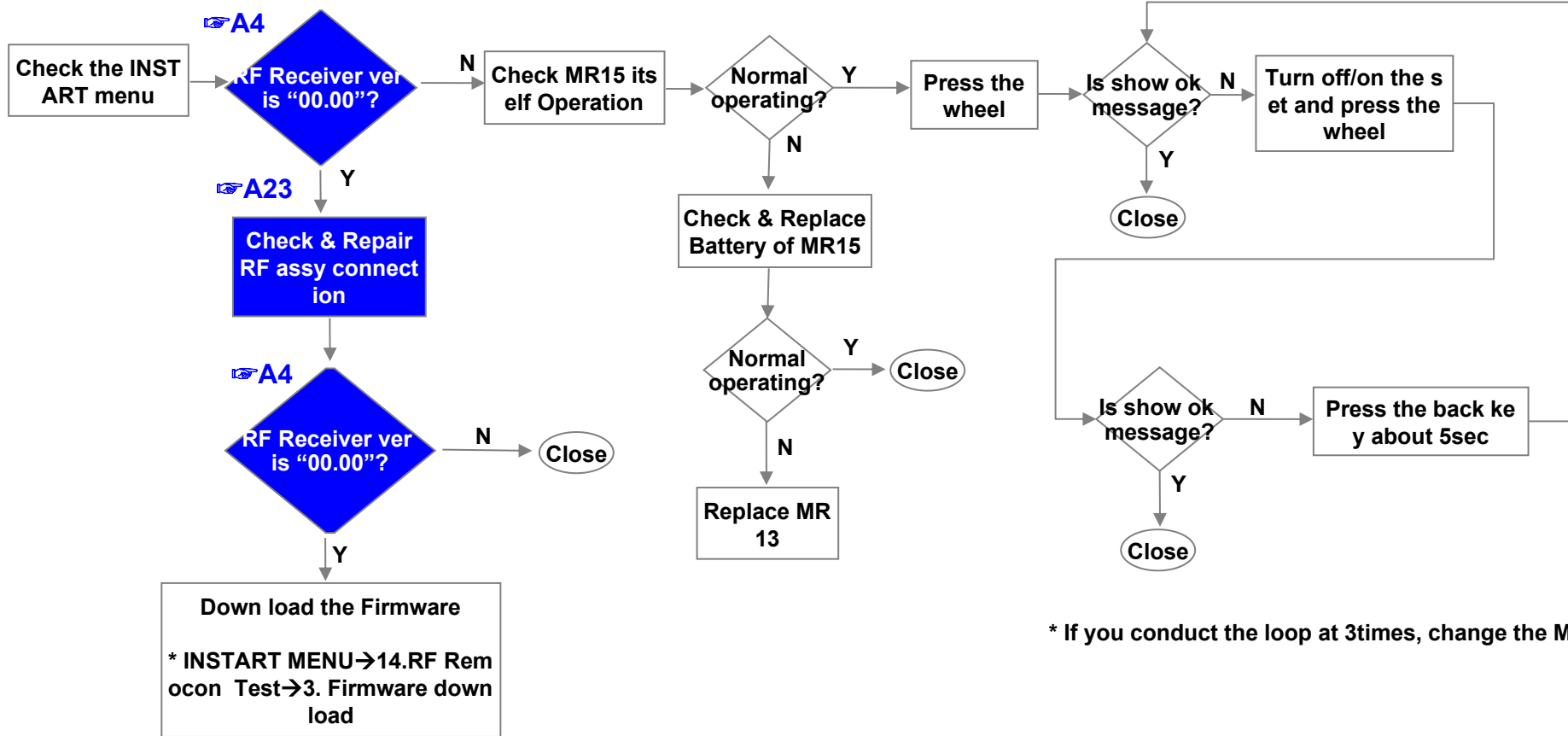

	Error symptom	D. Function error	Established date		
		Wifi operating checking	Revised date		12/16

3.Wifi operating error

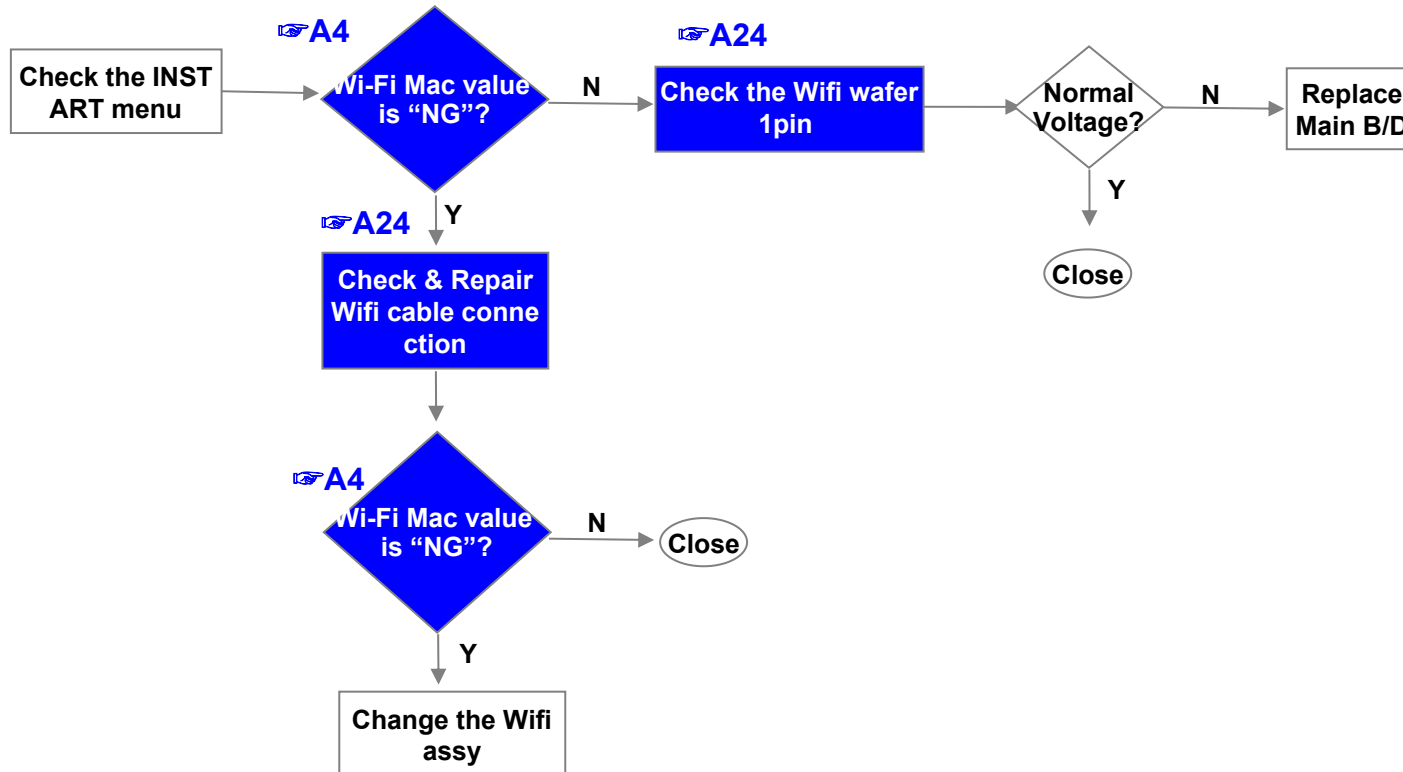

Standard Repair Process

	Error symptom	D. Function error	Established date		
		Camera operating checking	Revised date		13/16

4.Camera operating error (*Camera operation is not support*)

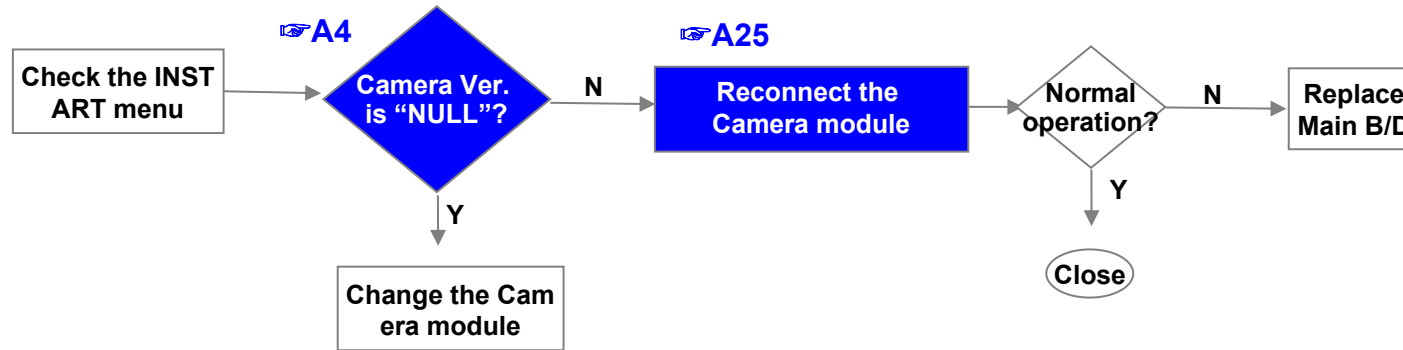

Standard Repair Process

	Error symptom	D. Function error	Established date	
		External device recognition error	Revised date	14/16

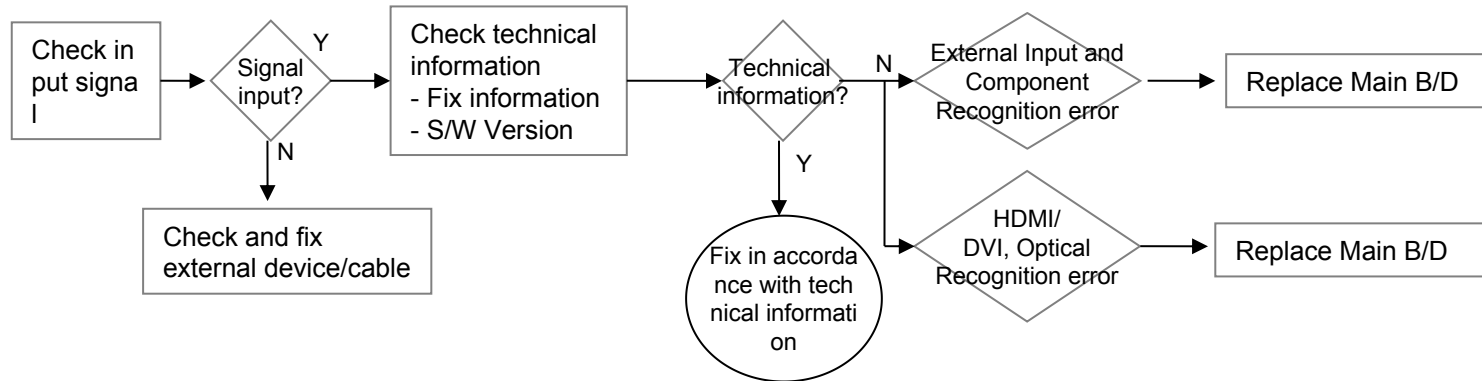

Standard Repair Process

	Error symptom	E. Noise	Established date		
		Circuit noise, mechanical noise	Revised date		15/16

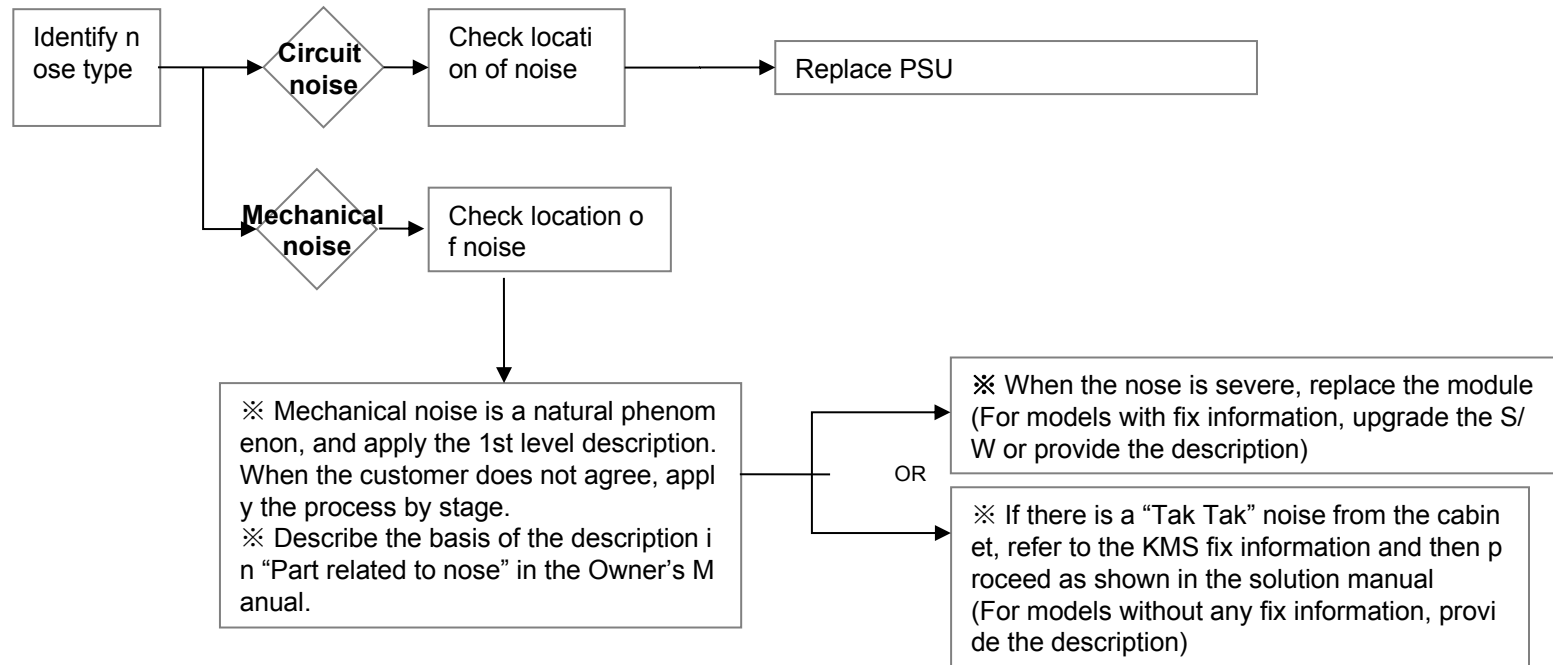

Standard Repair Process

	Error symptom	F. Exterior defect	Established date		
		Exterior defect	Revised date		16/16

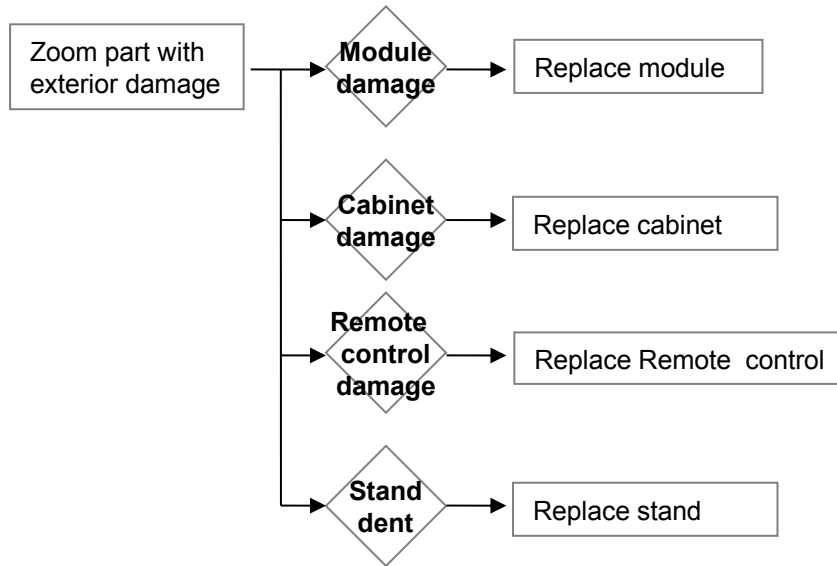

Contents of Standard Repair Process Detail Technical Manual

No.	Error symptom	Content	Page	Remarks
1	A. Video error_ No video/Normal audio	Check LCD back light with naked eye	A1	
2		Check White Balance value	A2	
3	A. Video error_ video error /Video lag/ stop	TUNER input signal strength checking method	A3	
4		Version checking method	A4	
5		Tuner Checking Part	A5	
6	A. Video error _Vertical/Horizontal bar, residual image, light spot	Connection diagram	A6	
7	A. Video error_ Color error	Check Link Cable reconnection condition	A7	
8		Adjustment Test pattern – ADJ Key	A8	
9	<Appendix> Defected Type caused by T-Con/ Inverter/ Module	Exchange Main Board (1)	A-1/5	
10		Exchange Main Board (2)	A-2/5	
11		Exchange Power Board (PSU)	A-3/5	
12		Exchange Module (1)	A-4/5	
13		Exchange Module (2)	A-5/5	

Contents of Standard Repair Process Detail Technical Manual

No.	Error symptom	Content	Page	Remarks
14	B. Power error_ No power	Check front display LED	A17	
15		Check power input Voltage & ST-BY 3.5V	A18	
16	B. Power error_Off when on, off while viewing	POWER OFF MODE checking method	A19	
17	C. Audio error_ No audio/Normal video	Checking method in menu when there is no audio	A20	
18		Voltage and speaker checking method when there is no audio	A21	
19	D. Function error	Remote control operation checking method	A22	
20		Motion Remote operation checking method	A23	Not Used
21		Wifi operation checking method	A24	
22		Camera operation checking method	A25	Not Used
23	E. Etc	Tool option changing method	A26	

Standard Repair Process Detail Technical Manual

	Error symptom	A. Video error_No video/Normal audio	Established date		
	Content	Check White Balance value	Revised date		A2

<ALL MODELS>

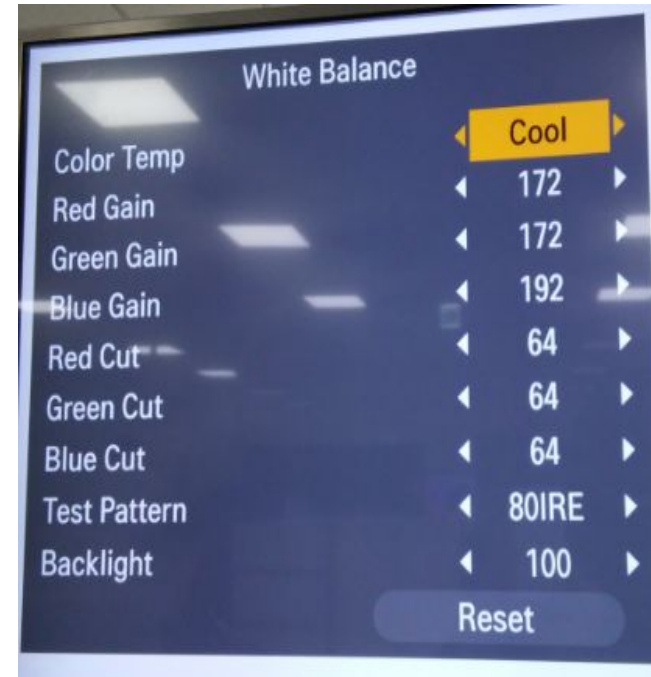
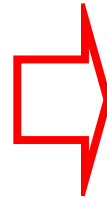
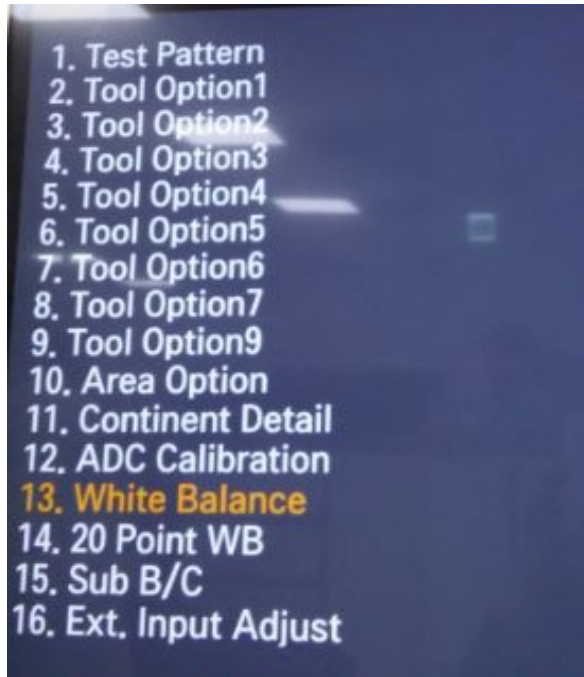

Entry method

1. Press the ADJ button on the Remote control for adjustment.
2. Enter into White Balance of item 13.
3. After recording the R, G, B (GAIN, Cut) value of Color Temp (Cool/Medium/Warm), re-enter the value after replacing the MAIN BOARD.

Standard Repair Process Detail Technical Manual

	Error symptom	A. Video error_Video error, video lag/stop	Established date		
	Content	TUNER input signal strength checking method	Revised date		A3

<ALL MODELS>

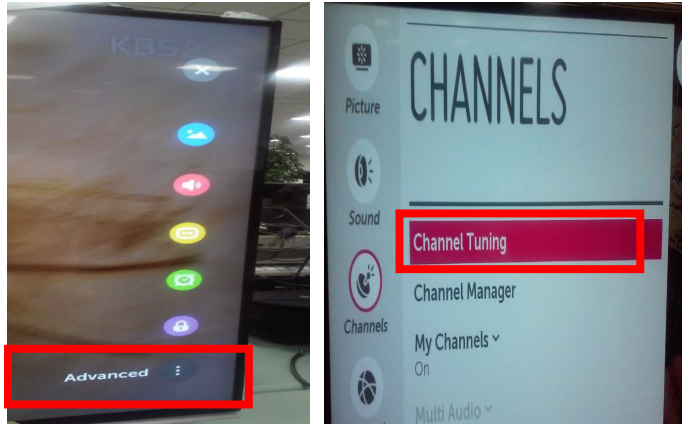

Advanced → Channels → Channel Tuning → Manual Tuning

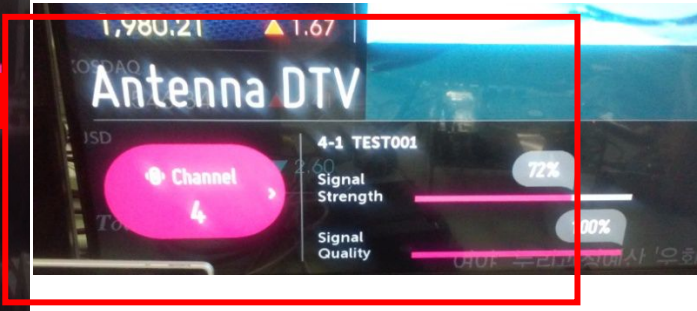
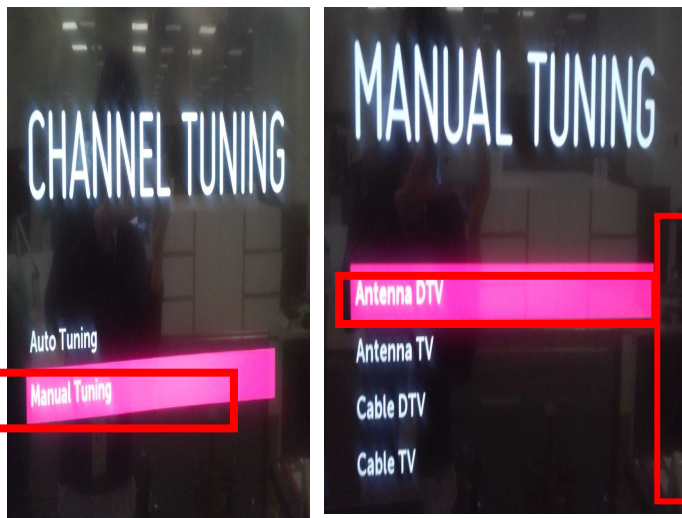

When the signal is strong, use the attenuator (-10dB, -15dB, -20dB etc.)



Standard Repair Process Detail Technical Manual

	Error symptom	A. Video error_Video error, video lag/stop	Established date		
	Content	Version checking method	Revised date		A4

<ALL MODELS>

1. Checking method for Remote control for adjustment

Version

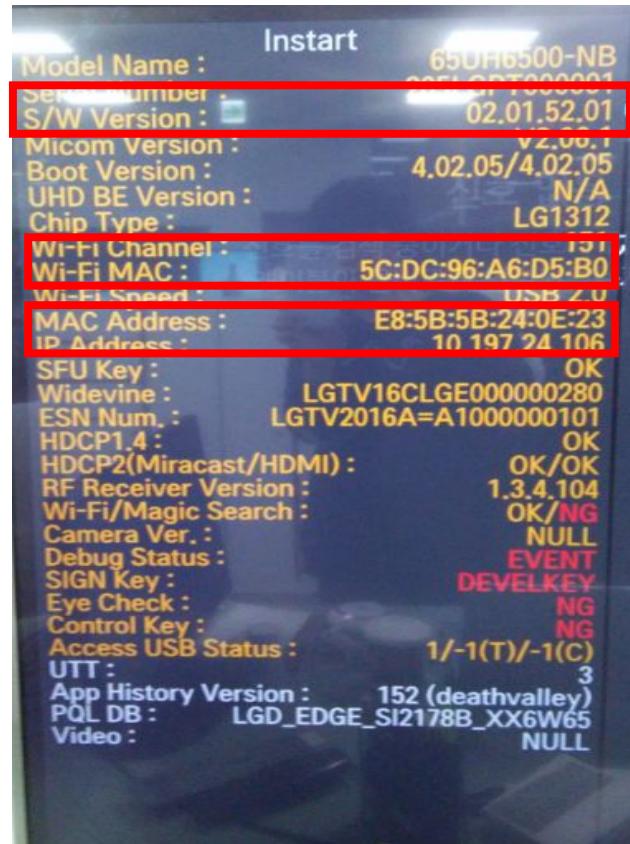

Press the IN-START with the Remote control for adjustment

Standard Repair Process Detail Technical Manual

	Error symptom	A. Video error_Video error, video lag/stop	Established date		
	Content	TUNER checking part	Revised date		A5

<ALL MODELS>

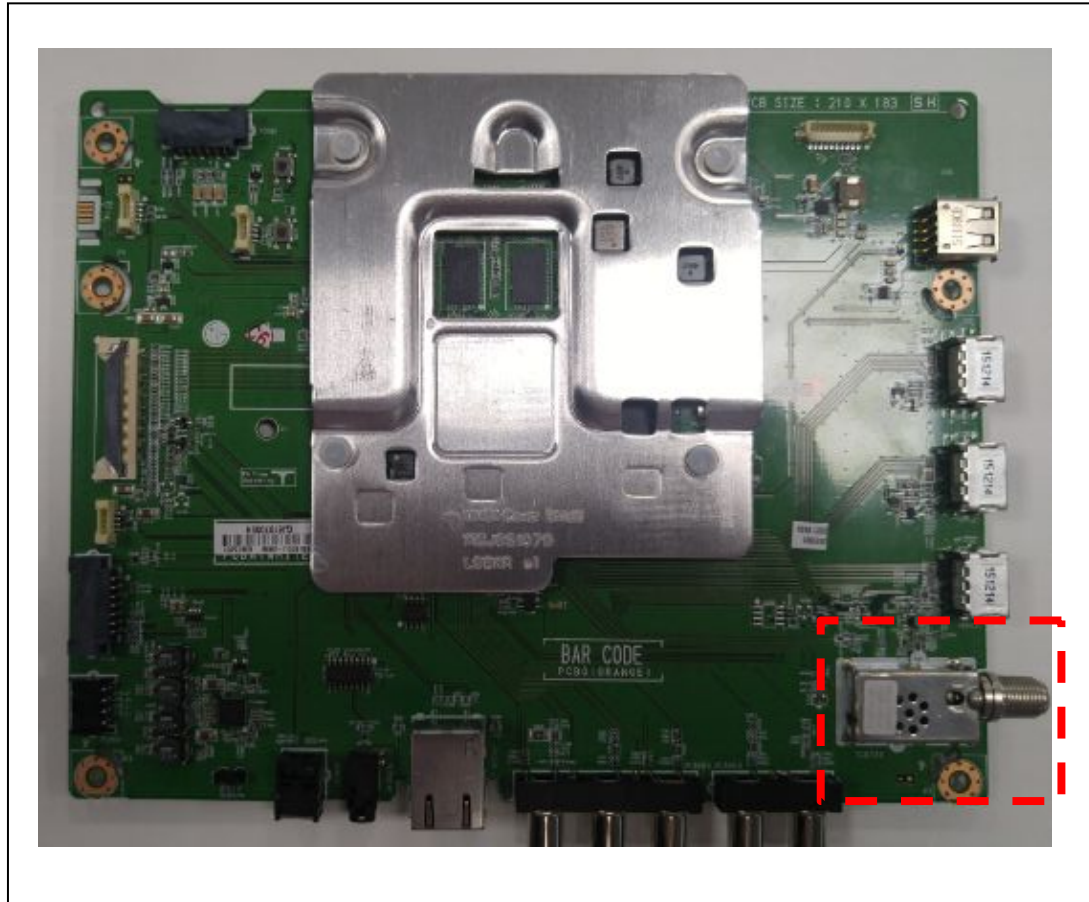

Checking method:

1. Check the signal strength or check whether the screen is normal when the external device is connected.
2. After measuring each voltage from power supply, finally replace the MAIN BOARD.
3. If you can't see the UHD live TV, please connect signal at left side of jack. (Korea model only)

Standard Repair Process Detail Technical Manual

	Error symptom	A. Video error _Vertical/Horizontal bar, residual image, light spot	Established date		
	Content	connection diagram (1)	Revised date		A6

<ALL MODELS>

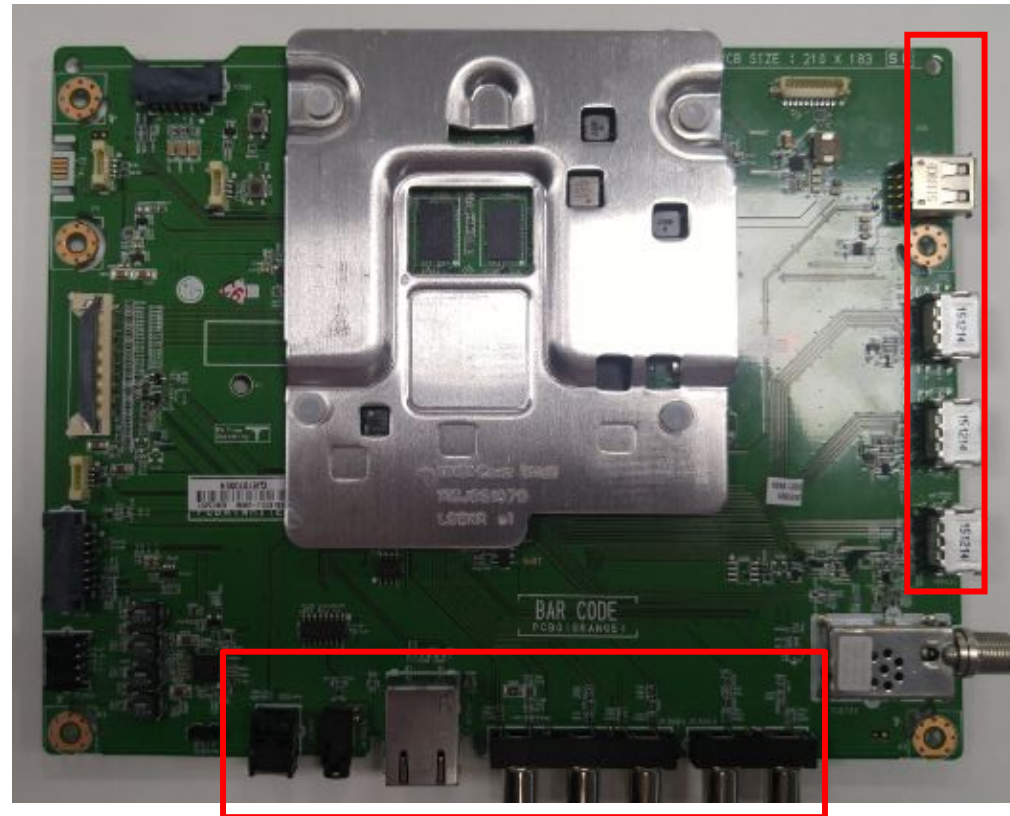

As the part connecting to the external input, check the screen condition by signal

Standard Repair Process Detail Technical Manual

	Error symptom	A. Video error_Color error	Established date		
	Content	Adjustment Test pattern - ADJ Key	Revised date		A8

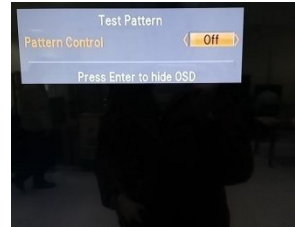
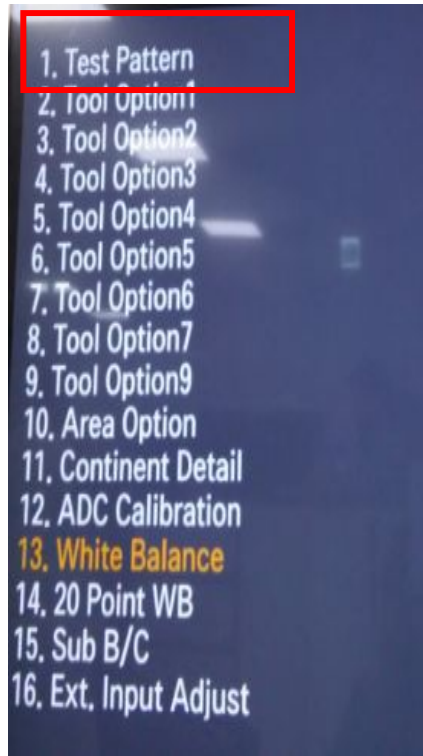

You can view 6 types of patterns using the ADJ Key

Checking item : 1. Defective pixel 2. Residual image 3. MODULE error (ADD-BAR,SCAN BAR..)
4.Video error (Classification of MODULE or Main-B/D!)

Appendix : Exchange Main Board (1)



Solder defect, CNT Broken

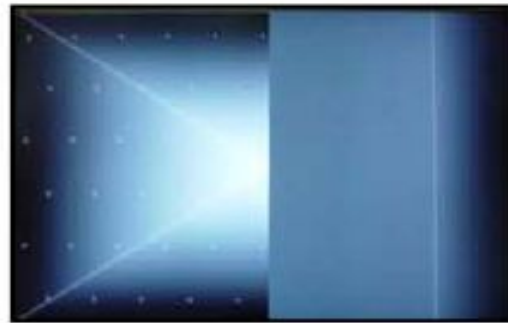

Solder defect, CNT Broken

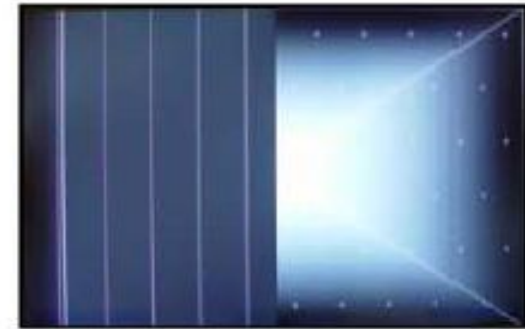

Solder defect, CNT Broken



Solder defect, CNT Broken

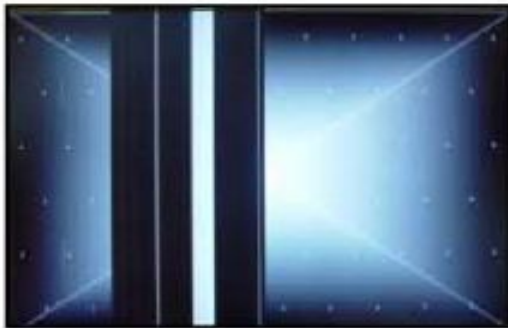

Solder defect, CNT Broken



Abnormal Power Section

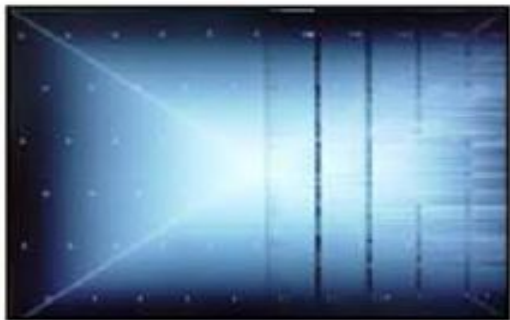

Solder defect, Short/Crack



Abnormal Power Section



Solder defect, Short/Crack

Appendix : Exchange Main Board (2)

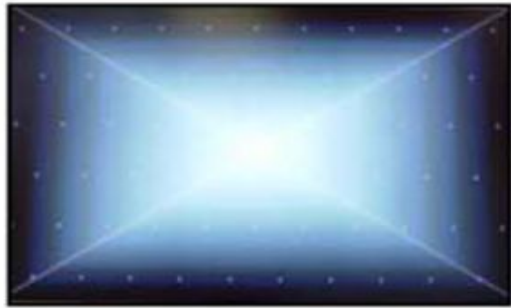

Abnormal Power Section



Abnormal Power Section



Solder defect, Short/Crack



Solder defect, Short/Crack



Fuse Open, Abnormal power section



Abnormal Display



GRADATION



Noise



GRADATION

Appendix : Exchange Power Board (PSU)



No Light



Dim Light

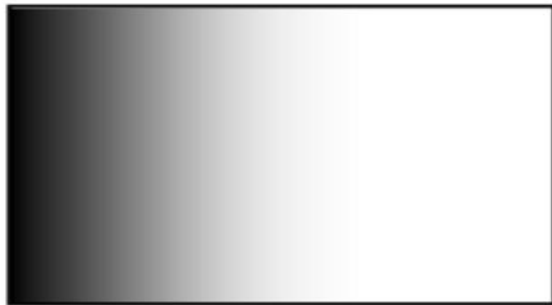

Dim Light

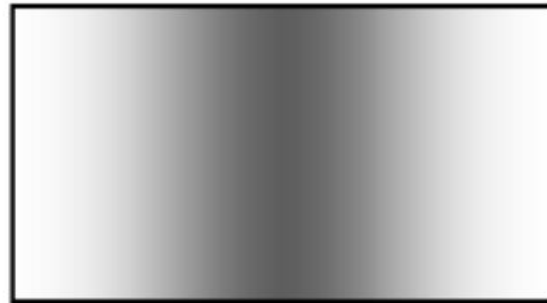

Dim Light



No picture/Sound Ok

Appendix : Exchange the Module (1)



Panel Mura, Light leakage



Panel Mura, Light leakage



Press damage

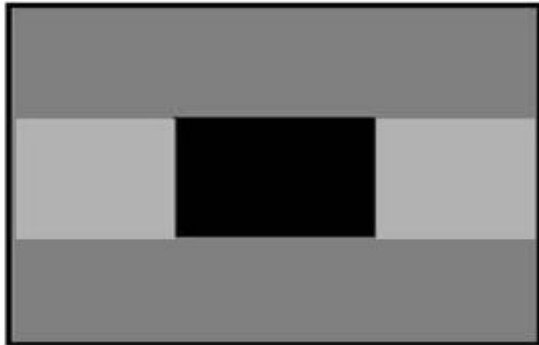

Crosstalk



Press damage



Crosstalk



Press damage

Un-repairable Cases

In this case please exchange the module.

Appendix : Exchange the Module (2)

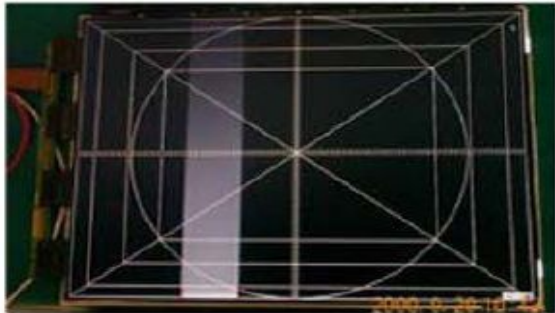

Vertical Block
Source TAB IC Defect



Vertical Line
Source TAB IC Defect



Vertical Block
Source TAB IC Defect



Horizontal Block
Gate TAB IC Defect



Horizontal Block
Gate TAB IC Defect

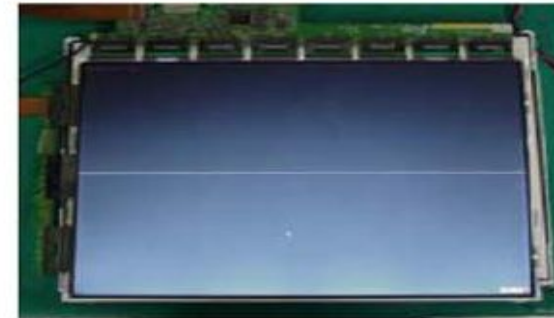

Horizontal line
Gate TAB IC Defect



Horizontal Block
Gate TAB IC Defect

Un-repairable Cases

In this case please exchange the module.

Standard Repair Process Detail Technical Manual

	Error symptom	B. Power error _No power	Established date		
	Content	Check front Power Indicator	Revised date		A17

<50/65UH55>

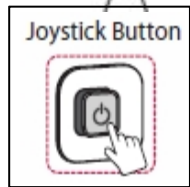

Joystick button

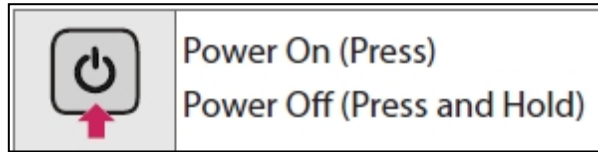

ST-BY condition: On or Off
Power ON condition: Turn Off

North America model doesn't use lum.sensor

Standard Repair Process Detail Technical Manual

	Error symptom	B. Power error _No power	Established date	
	Content	Check power input voltage and ST-BY 3.5V	Revised date	A18

Check the DC 13.2V

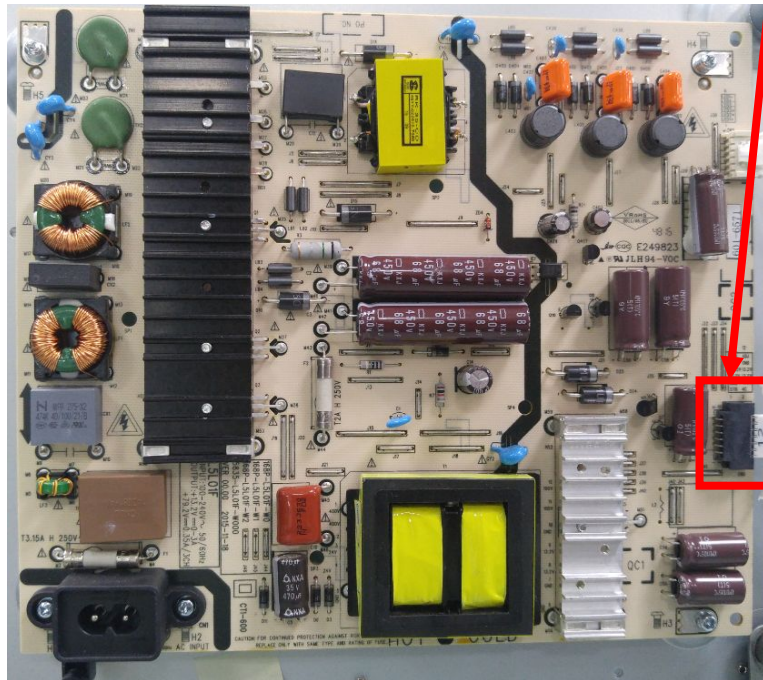

50UH5500-UA

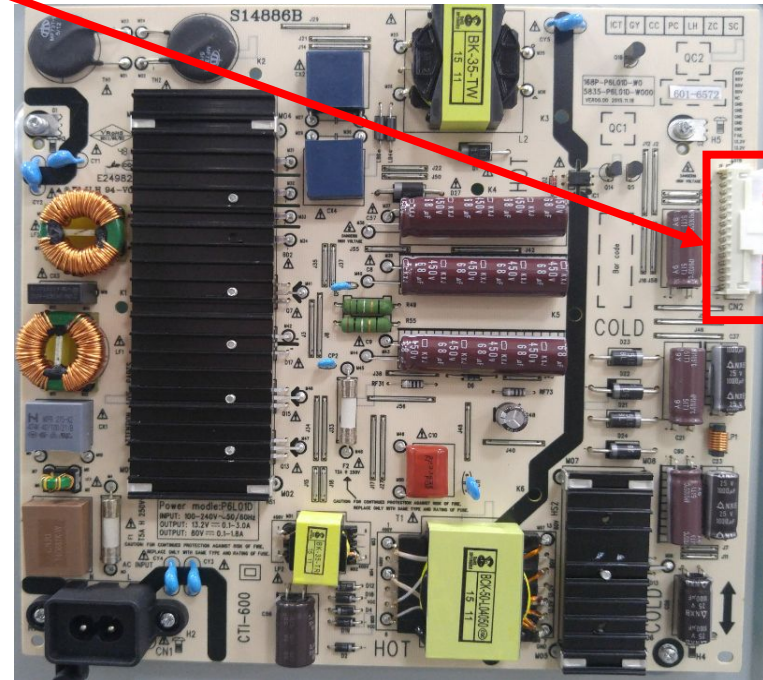

65UH5500-UA

Standard Repair Process Detail Technical Manual

	Error symptom	B. Power error _Off when on, off whiling viewing	Established date		
	Content	POWER OFF MODE checking method	Revised date		A19

<ALL MODELS>

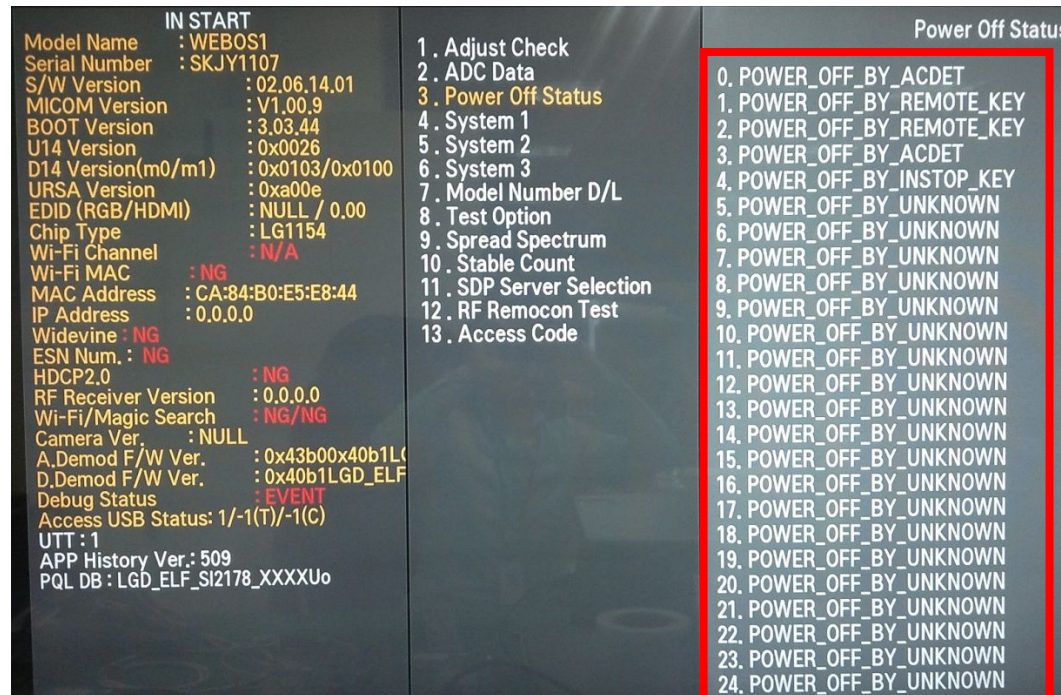

Entry method

1. Press the IN-START button of the Remote control for adjustment
2. Check the entry into adjustment item 3

Standard Repair Process Detail Technical Manual

	Error symptom	C. Audio error_No audio/Normal video	Established date		
	Content	Checking method in menu when there is no audio	Revised date		A20

<ALL MODELS>

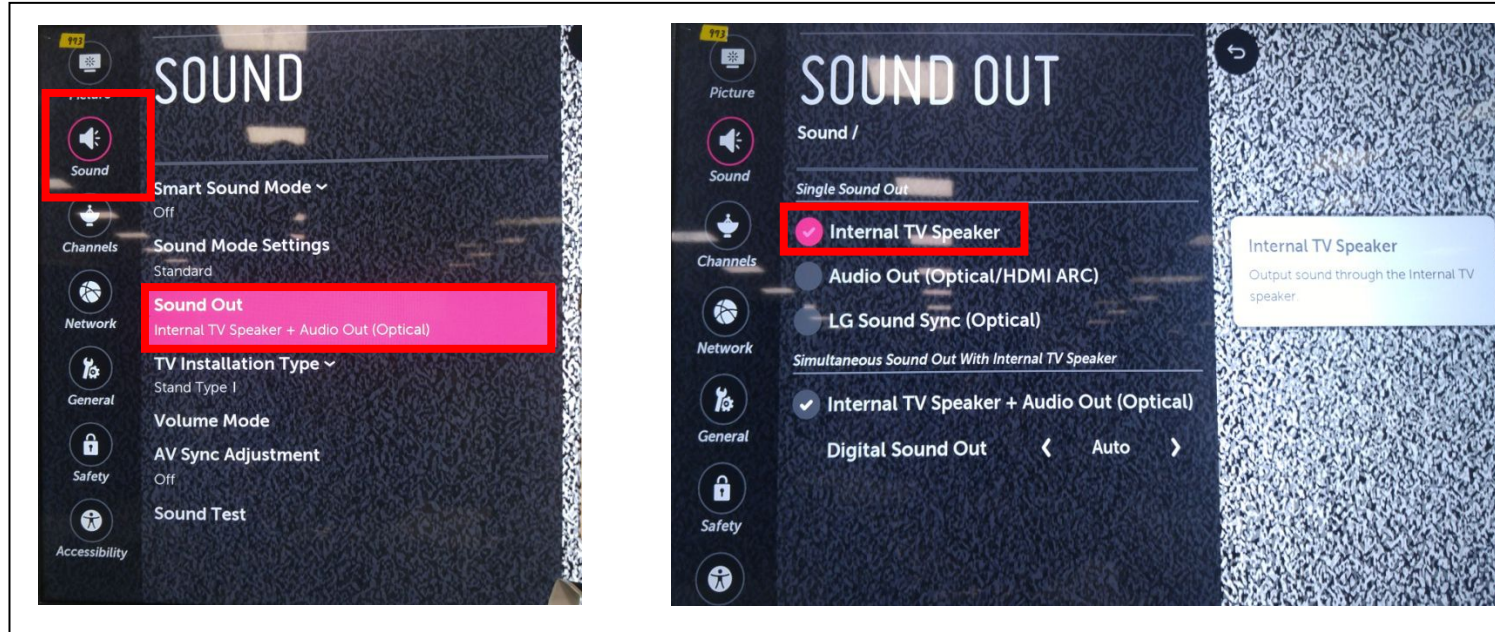

Checking method

1. Press the Setting button on the Remote control
2. Select the Sound function of the Menu
3. Select the Sound Out
4. Select TV Speaker

Standard Repair Process Detail Technical Manual

	Error symptom	C. Audio error_No audio/Normal video	Established date	
	Content	Voltage and speaker checking method when there is no audio	Revised date	A21

<50/65UH5500-UA>

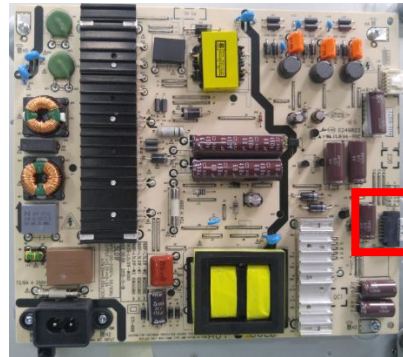

50UH5500-UA

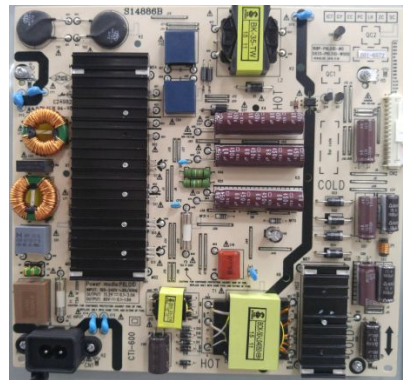

65UH5500-UA

P201 YEONHO (SMAW200-H12S5K)			
Pin No.	Assignment	Pin No.	Assignment
1	PWR-ON	2	N.C
3	GND	4	13.2V
5	13.2V	6	13.2V
7	13.2V	8	13.2V
9	GND	10	GND
11	MS	12	P-DIM1

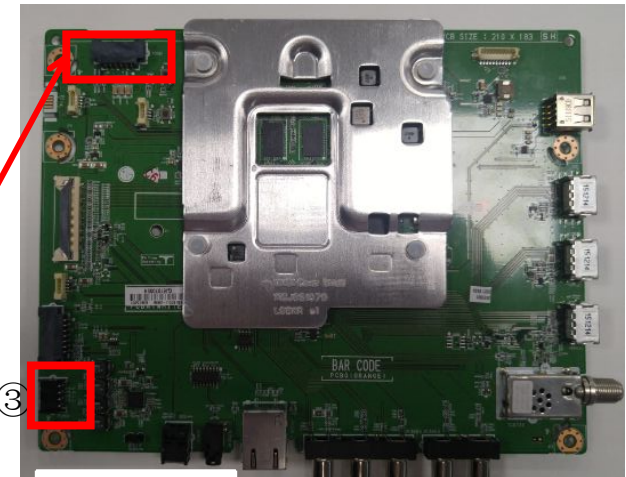

- 1 SPK_R-
- 2 SPK_R+
- 3 SPK_L-
- 4 SPK_L+

Checking order when there is no audio

1. Check the contact condition of or 13V connector of Main Board

2. Measure the 13V input voltage supplied from Power Board
(If there is no input voltage, remove and check the connector)

3. Connect the tester RX1 to the speaker terminal and if you hear the Chik Chik sound when you touch the GND and output terminal, the speaker is normal.

Standard Repair Process Detail Technical Manual

	Error symptom	D. Function error	Established date		
	Content	Remote control operation checking method	Revised date		A22

<50/65UH5500-UA>

①

IR & Control Key front



IR & Control Key Rear

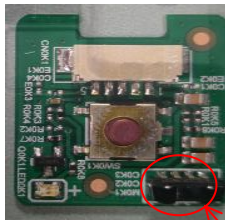

IR

②

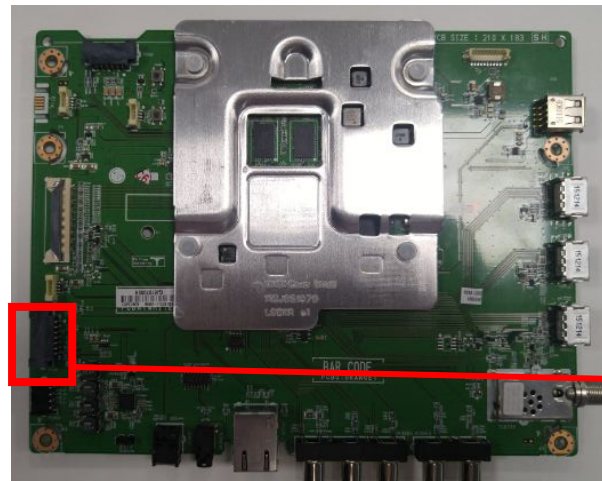

③

- 1 GND
- 2 +3.5V_WIFI
- 3 WOL/WIFI_POWER_ON_JACK
- 4 WIFI_DM_JACK
- 5 GND
- 6 WIFI_DP_JACK
- 7 NC
- 8 NC
- 9 GND
- 10 KEY2
- 11 IR
- 12 +3.5V_ST
- 13 LED_R_JACK
- 14 GND
- 15 GND

Checking order to check Remote control

Checking order

1. Check IR cable condition between IR & Main board. (Check picture number ① and ②)
2. Check the standby 3.5V on the terminal 15 pin (③)
3. AS checking the Pre-Amp (IR LED light), the power is in ON condition, an Analog Tester needle should move slowly, otherwise, it's defective.

Standard Repair Process Detail Technical Manual

	Error symptom	D. Function error	Established date		
	Content	Remote controperation checking method	Revised date		A22

< 50/65UH5500-UA >

① Wifi Front

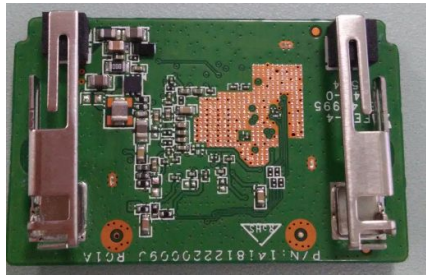

Wifi Rear

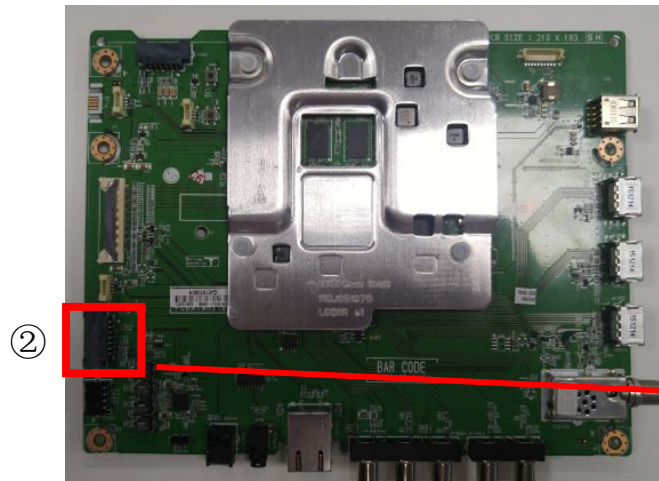

- 1 GND
- 2 +3.5V_WIFI
- 3 WOL/WIFI_POWER_ON_JACK
- 4 WIFI_DM_JACK
- 5 GND
- 6 WIFI_DP_JACK
- 7 NC
- 8 NC
- 9 GND
- 10 KEY2
- 11 IR
- 12 +3.5V_ST
- 13 LED_R_JACK
- 14 GND
- 15 GND

Checking order to check wifi

Checking order

1. Check BT/Wifi cable condition between BT/Wifi assy & Main board.
2. Check the 3.5V on the terminal 1 (+3.5V_WIFI)