



LG

Life's Good

North/Latin America
Europe/Africa
Asia/Oceania

Internal Use Only

<http://aic.lgservice.com>
<http://eic.lgservice.com>
<http://biz.lgservice.com>

LED TV

SERVICE MANUAL

CHASSIS : LA49B

MODEL : 55LB5500/55LB5550
55LB5500-UZ/55LB5550-UY

CAUTION

BEFORE SERVICING THE CHASSIS,
READ THE SAFETY PRECAUTIONS IN THIS MANUAL.

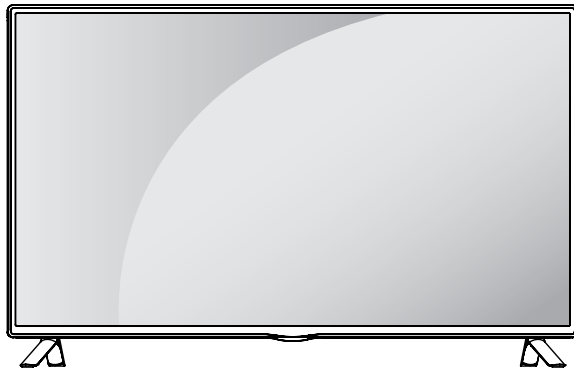

CONTENTS

CONTENTS	2
PRODUCT SAFETY	3
SPECIFICATION	4
ADJUSTMENT INSTRUCTION	9
TROUBLE SHOOTING	16
BLOCK DIAGRAM.....	22
EXPLODED VIEW	23
SCHEMATIC CIRCUIT DIAGRAM	

SAFETY PRECAUTIONS

IMPORTANT SAFETY NOTICE

Many electrical and mechanical parts in this chassis have special safety-related characteristics. These parts are identified by \triangle in the Schematic Diagram and Exploded View.

It is essential that these special safety parts should be replaced with the same components as recommended in this manual to prevent Shock, Fire, or other Hazards.

Do not modify the original design without permission of manufacturer.

General Guidance

An **isolation Transformer should always be used** during the servicing of a receiver whose chassis is not isolated from the AC power line. Use a transformer of adequate power rating as this protects the technician from accidents resulting in personal injury from electrical shocks.

It will also protect the receiver and its components from being damaged by accidental shorts of the circuitry that may be inadvertently introduced during the service operation.

If any fuse (or Fusible Resistor) in this TV receiver is blown, replace it with the specified.

When replacing a high wattage resistor (Oxide Metal Film Resistor, over 1 W), keep the resistor 10 mm away from PCB.

Keep wires away from high voltage or high temperature parts.

Before returning the receiver to the customer,

always perform an **AC leakage current check** on the exposed metallic parts of the cabinet, such as antennas, terminals, etc., to be sure the set is safe to operate without damage of electrical shock.

Leakage Current Cold Check(Antenna Cold Check)

With the instrument AC plug removed from AC source, connect an electrical jumper across the two AC plug prongs. Place the AC switch in the on position, connect one lead of ohm-meter to the AC plug prongs tied together and touch other ohm-meter lead in turn to each exposed metallic parts such as antenna terminals, phone jacks, etc.

If the exposed metallic part has a return path to the chassis, the measured resistance should be between 1 M Ω and 5.2 M Ω .

When the exposed metal has no return path to the chassis the reading must be infinite.

An other abnormality exists that must be corrected before the receiver is returned to the customer.

Leakage Current Hot Check (See below Figure)

Plug the AC cord directly into the AC outlet.

Do not use a line Isolation Transformer during this check.

Connect 1.5 K / 10 watt resistor in parallel with a 0.15 uF capacitor between a known good earth ground (Water Pipe, Conduit, etc.) and the exposed metallic parts.

Measure the AC voltage across the resistor using AC voltmeter with 1000 ohms/volt or more sensitivity.

Reverse plug the AC cord into the AC outlet and repeat AC voltage measurements for each exposed metallic part. Any voltage measured must not exceed 0.75 volt RMS which corresponds to 0.5 mA.

In case any measurement is out of the limits specified, there is possibility of shock hazard and the set must be checked and repaired before it is returned to the customer.

Leakage Current Hot Check circuit

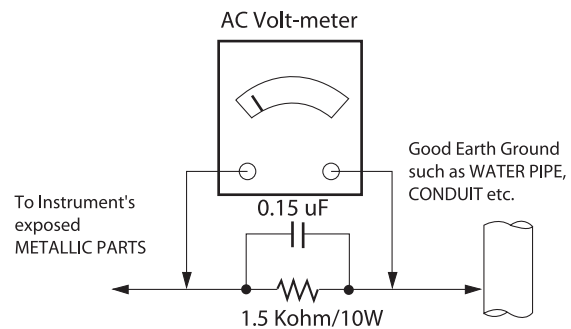

When 25A is impressed between Earth and 2nd Ground for 1 second, Resistance must be less than 0.1 Ω

*Base on Adjustment standard

SERVICING PRECAUTIONS

CAUTION: Before servicing receivers covered by this service manual and its supplements and addenda, read and follow the **SAFETY PRECAUTIONS** on page 3 of this publication.
NOTE: If unforeseen circumstances create conflict between the following servicing precautions and any of the safety precautions on page 3 of this publication, always follow the safety precautions. Remember: Safety First.

General Servicing Precautions

1. Always unplug the receiver AC power cord from the AC power source before;
 - a. Removing or reinstalling any component, circuit board module or any other receiver assembly.
 - b. Disconnecting or reconnecting any receiver electrical plug or other electrical connection.
 - c. Connecting a test substitute in parallel with an electrolytic capacitor in the receiver.
CAUTION: A wrong part substitution or incorrect polarity installation of electrolytic capacitors may result in an explosion hazard.
2. Test high voltage only by measuring it with an appropriate high voltage meter or other voltage measuring device (DVM, FETVOM, etc) equipped with a suitable high voltage probe. Do not test high voltage by "drawing an arc".
3. Do not spray chemicals on or near this receiver or any of its assemblies.
4. Unless specified otherwise in this service manual, clean electrical contacts only by applying the following mixture to the contacts with a pipe cleaner, cotton-tipped stick or comparable non-abrasive applicator; 10 % (by volume) Acetone and 90 % (by volume) isopropyl alcohol (90 % - 99 % strength)
CAUTION: This is a flammable mixture.
Unless specified otherwise in this service manual, lubrication of contacts is not required.
5. Do not defeat any plug/socket B+ voltage interlocks with which receivers covered by this service manual might be equipped.
6. Do not apply AC power to this instrument and/or any of its electrical assemblies unless all solid-state device heat sinks are correctly installed.
7. Always connect the test receiver ground lead to the receiver chassis ground before connecting the test receiver positive lead.
Always remove the test receiver ground lead last.
8. Use with this receiver only the test fixtures specified in this service manual.
CAUTION: Do not connect the test fixture ground strap to any heat sink in this receiver.

Electrostatically Sensitive (ES) Devices

Some semiconductor (solid-state) devices can be damaged easily by static electricity. Such components commonly are called Electrostatically Sensitive (ES) Devices. Examples of typical ES devices are integrated circuits and some field-effect transistors and semiconductor "chip" components. The following techniques should be used to help reduce the incidence of component damage caused by static by static electricity.

1. Immediately before handling any semiconductor component or semiconductor-equipped assembly, drain off any electrostatic charge on your body by touching a known earth ground. Alternatively, obtain and wear a commercially available discharging wrist strap device, which should be removed to prevent potential shock reasons prior to applying power to the unit under test.

2. After removing an electrical assembly equipped with ES devices, place the assembly on a conductive surface such as aluminum foil, to prevent electrostatic charge buildup or exposure of the assembly.
3. Use only a grounded-tip soldering iron to solder or unsolder ES devices.
4. Use only an anti-static type solder removal device. Some solder removal devices not classified as "anti-static" can generate electrical charges sufficient to damage ES devices.
5. Do not use freon-propelled chemicals. These can generate electrical charges sufficient to damage ES devices.
6. Do not remove a replacement ES device from its protective package until immediately before you are ready to install it. (Most replacement ES devices are packaged with leads electrically shorted together by conductive foam, aluminum foil or comparable conductive material).
7. Immediately before removing the protective material from the leads of a replacement ES device, touch the protective material to the chassis or circuit assembly into which the device will be installed.
CAUTION: Be sure no power is applied to the chassis or circuit, and observe all other safety precautions.
8. Minimize bodily motions when handling unpackaged replacement ES devices. (Otherwise harmless motion such as the brushing together of your clothes fabric or the lifting of your foot from a carpeted floor can generate static electricity sufficient to damage an ES device.)

General Soldering Guidelines

1. Use a grounded-tip, low-wattage soldering iron and appropriate tip size and shape that will maintain tip temperature within the range or 500 °F to 600 °F.
2. Use an appropriate gauge of RMA resin-core solder composed of 60 parts tin/40 parts lead.
3. Keep the soldering iron tip clean and well tinned.
4. Thoroughly clean the surfaces to be soldered. Use a small wire-bristle (0.5 inch, or 1.25 cm) brush with a metal handle. Do not use freon-propelled spray-on cleaners.
5. Use the following unsoldering technique
 - a. Allow the soldering iron tip to reach normal temperature. (500 °F to 600 °F)
 - b. Heat the component lead until the solder melts.
 - c. Quickly draw the melted solder with an anti-static, suction-type solder removal device or with solder braid.
CAUTION: Work quickly to avoid overheating the circuit board printed foil.
6. Use the following soldering technique.
 - a. Allow the soldering iron tip to reach a normal temperature (500 °F to 600 °F)
 - b. First, hold the soldering iron tip and solder the strand against the component lead until the solder melts.
 - c. Quickly move the soldering iron tip to the junction of the component lead and the printed circuit foil, and hold it there only until the solder flows onto and around both the component lead and the foil.
CAUTION: Work quickly to avoid overheating the circuit board printed foil.
 - d. Closely inspect the solder area and remove any excess or splashed solder with a small wire-bristle brush.

IC Remove/Replacement

Some chassis circuit boards have slotted holes (oblong) through which the IC leads are inserted and then bent flat against the circuit foil. When holes are the slotted type, the following technique should be used to remove and replace the IC. When working with boards using the familiar round hole, use the standard technique as outlined in paragraphs 5 and 6 above.

Removal

1. Desolder and straighten each IC lead in one operation by gently prying up on the lead with the soldering iron tip as the solder melts.
2. Draw away the melted solder with an anti-static suction-type solder removal device (or with solder braid) before removing the IC.

Replacement

1. Carefully insert the replacement IC in the circuit board.
2. Carefully bend each IC lead against the circuit foil pad and solder it.
3. Clean the soldered areas with a small wire-bristle brush. (It is not necessary to reapply acrylic coating to the areas).

"Small-Signal" Discrete Transistor Removal/Replacement

1. Remove the defective transistor by clipping its leads as close as possible to the component body.
2. Bend into a "U" shape the end of each of three leads remaining on the circuit board.
3. Bend into a "U" shape the replacement transistor leads.
4. Connect the replacement transistor leads to the corresponding leads extending from the circuit board and crimp the "U" with long nose pliers to insure metal to metal contact then solder each connection.

Power Output, Transistor Device

Removal/Replacement

1. Heat and remove all solder from around the transistor leads.
2. Remove the heat sink mounting screw (if so equipped).
3. Carefully remove the transistor from the heat sink of the circuit board.
4. Insert new transistor in the circuit board.
5. Solder each transistor lead, and clip off excess lead.
6. Replace heat sink.

Diode Removal/Replacement

1. Remove defective diode by clipping its leads as close as possible to diode body.
2. Bend the two remaining leads perpendicular y to the circuit board.
3. Observing diode polarity, wrap each lead of the new diode around the corresponding lead on the circuit board.
4. Securely crimp each connection and solder it.
5. Inspect (on the circuit board copper side) the solder joints of the two "original" leads. If they are not shiny, reheat them and if necessary, apply additional solder.

Fuse and Conventional Resistor

Removal/Replacement

1. Clip each fuse or resistor lead at top of the circuit board hollow stake.
2. Securely crimp the leads of replacement component around notch at stake top.

3. Solder the connections.

CAUTION: Maintain original spacing between the replaced component and adjacent components and the circuit board to prevent excessive component temperatures.

Circuit Board Foil Repair

Excessive heat applied to the copper foil of any printed circuit board will weaken the adhesive that bonds the foil to the circuit board causing the foil to separate from or "lift-off" the board. The following guidelines and procedures should be followed whenever this condition is encountered.

At IC Connections

To repair a defective copper pattern at IC connections use the following procedure to install a jumper wire on the copper pattern side of the circuit board. (Use this technique only on IC connections).

1. Carefully remove the damaged copper pattern with a sharp knife. (Remove only as much copper as absolutely necessary).
2. Carefully scratch away the solder resist and acrylic coating (if used) from the end of the remaining copper pattern.
3. Bend a small "U" in one end of a small gauge jumper wire and carefully crimp it around the IC pin. Solder the IC connection.
4. Route the jumper wire along the path of the out-away copper pattern and let it overlap the previously scraped end of the good copper pattern. Solder the overlapped area and clip off any excess jumper wire.

At Other Connections

Use the following technique to repair the defective copper pattern at connections other than IC Pins. This technique involves the installation of a jumper wire on the component side of the circuit board.

1. Remove the defective copper pattern with a sharp knife. Remove at least 1/4 inch of copper, to ensure that a hazardous condition will not exist if the jumper wire opens.
2. Trace along the copper pattern from both sides of the pattern break and locate the nearest component that is directly connected to the affected copper pattern.
3. Connect insulated 20-gauge jumper wire from the lead of the nearest component on one side of the pattern break to the lead of the nearest component on the other side. Carefully crimp and solder the connections.
CAUTION: Be sure the insulated jumper wire is dressed so the it does not touch components or sharp edges.

SPECIFICATION

NOTE : Specifications and others are subject to change without notice for improvement.

1. Application range

This spec sheet is applied LED TV with LA49Bchassis

2. Test condition

Each part is tested as below without special notice.

- 1) Temperature : 25 °C ± 5 °C(77 ± 9 °F) , CST : 40 °C±5 °C
- 2) Relative Humidity: 65 % ± 10 %
- 3) Power Voltage

Market	Input voltage	Frequency	Remark
USA	110~240V	50/60Hz	Standard Voltage of each product is marked by models

- 4) Specification and performance of each parts are followed each drawing and specification by part number in accordance with BOM
- 5) The receiver must be operated for about 20 minutes prior to the adjustment

3. Test method

- 1) Performance: LGE TV test method followed
- 2) Demanded other specification
 - Safety : UL, CSA, IEC specification
 - EMC: FCC, ICES, IEC specification

4. General Specification

No	Item	Specification	Result	Remark
1.	Receiving System	1) ATSC / NTSC-M / 64 QAM / 256 QAM		
2.	Available Channel	1) VHF : 02~13 2) UHF : 14~69 3) DTV : 02-69 4) CATV : 01~135 5) CADTV : 01~135		
3.	Input Voltage	AC 110V, 60HZ		Mark : 110V, 60Hz (N.America)
4.	Market	NORTH AMERICA		
5.	Screen Size	32/42 inch Wide (1920 × 1080)	FHD + 60Hz	32LB5600-UZ 39LB5600-UZ 42LB5500-UZ 42LB5600-UZ 49LB5500-UZ 55LB5500-UZ
		32 inch Wide (1366 × 768)	HD + 60Hz	32LB550B-UZ 32LB560B-UZ
6.	Aspect Ratio	16:9		
7.	Tuning System	FS		

No	Item	Specification	Result	Remark	
8.	Module	DIRECT L	LC320DUE-FGA3	LGD	32LB5600-UZ
		DIRECT L	LC320DXE-FGA3	LGD	32LB560B-UZ
		DIRECT L	LC320DXE-FGA5	LGD	32LB550B-UZ
		DIRECT L	NC320DXN-VSBP1	Sharp	32LB560B-UZ
		DIRECT L	NC320DXN-VSBP3	Sharp	32LB550B-UZ
		DIRECT L	NC390DUN-VXBP1	INX	39LB5600-UZ
		DIRECT L	LC420DUE-FGA3	LGD	42LB5600-UZ
		DIRECT L	LC420DUE-FGA5	LGD	42LB5500-UZ
		DIRECT L	T420HVF07.1	AUO	42LB5600-UZ
		DIRECT L	LC490DUE-FGA5	LGD	49LB5500-UZ
		DIRECT L	LC550DUE-FGA5	LGD	55LB5500-UZ
		DIRECT L	HC550DUN-ABHR1	BOE	55LB5500-UZ
9.	Operating Environment	1) Temp : 0 ~ 40 deg 2) Humidity : ~ 80 %			
10.	Storage Environment	1) Temp : -20 ~ 60 deg 2) Humidity : ~ 85 %			

5. Supported video resolutions

5.1. Component input(Y, CB/PB, CR/PR)

No	Resolution	H-freq(kHz)	V-freq.(kHz)	Pixel clock	Proposed
1.	720*480	15.73	59.94	13.50	SDTV ,DVD 480I
2.	720*480	15.73	60.00	13.5135	SDTV ,DVD 480I
3.	720*480	31.47	59.94	27.00	SDTV 480P
4.	720*480	31.50	60.00	27.027	SDTV 480P
5.	1280*720	44.96	59.94	74.176	HDTV 720P
6.	1280*720	45.00	60.00	74.25	HDTV 720P
7.	1920*1080	33.72	59.94	74.176	HDTV 1080I
8.	1920*1080	33.75	60.00	74.25	HDTV 1080I
9.	1920*1080	26.97	23.976	74.176	HDTV 1080P
10.	1920*1080	27.00	24.00	74.25	HDTV 1080P
11.	1920*1080	33.71	29.97	74.176	HDTV 1080P
12.	1920*1080	33.75	30.00	74.25	HDTV 1080P
13.	1920*1080	67.432	59.94	148.352	HDTV 1080P
14.	1920*1080	67.50	60.00	148.50	HDTV 1080P

5.2. HDMI Input (DTV/PC)

No	Resolution	H-freq(kHz)	V-freq.(kHz)	Pixel clock	Proposed	Remark	
	DTV						
1	720*480	15.73	59.94			Spec-Out. (Just Display)	
2	720*480	15.73	60.00				
3	720*480	31.47	59.94	27.00	SDTV 480P		
4	720*480	31.50	60.00	27.027	SDTV 480P		
5	1280*720	44.96	59.94	74.176	HDTV 720P		
6	1280*720	45.00	60.00	74.25	HDTV 720P		
7	1920*1080	33.72	59.94	74.176	HDTV 1080I		
8	1920*1080	33.75	60.00	74.25	HDTV 1080I		
9	1920*1080	26.97	23.976	74.176	HDTV 1080P		
10	1920*1080	27.00	24.00	74.25	HDTV 1080P		
11	1920*1080	33.71	29.97	74.176	HDTV 1080P		
12	1920*1080	33.75	30.00	74.25	HDTV 1080P		
13	1920*1080	67.432	59.94	148.352	HDTV 1080P		
14	1920*1080	67.50	60.00	148.50	HDTV 1080P		
	PC					DDC	
1	640*350	31.468	70.09	25.17	EGA	X	
2	720*400	31.469	70.08	28.32	DOS	O	
3	640*480	31.469	59.94	25.17	VESA(VGA)	O	
4	800*600	37.879	60.31	40.00	VESA(SVGA)	O	
5	1024*768	48.363	60.00	65.00	VESA(XGA)	O	
6	1360*768	47.712	60.015	85.50	VESA (WXGA)	O	
7	1152*864	54.348	60.053	80.002	VESA	O	
8	1280*1024	63.981	60.020	108.0	VESA (SXGA)	O	Full HD model Only
9	1920*1080	67.50	60.00	148.5	HDTV 1080P	O	Full HD model Only

ADJUSTMENT INSTRUCTION

1. Application

This spec. sheet applies to LA49B Chassis applied LED TV all models manufactured in TV factory

2. Specification

- (1) Because this is not a hot chassis, it is not necessary to use an isolation transformer. However, the use of isolation transformer will help protect test instrument.
- (2) Adjustment must be done in the correct order.
- (3) The adjustment must be performed in the circumstance of 25 ±5 °C of temperature and 65±10% of relative humidity if there is no specific designation
- (4) The input voltage of the receiver must keep 100~240V, 50/60Hz
- (5) At first Worker must turn on the SET by using Power Only key.
- (6) The receiver must be operated for about 5 minutes prior to the adjustment when module is in the circumstance of over 15 °C
In case of keeping module is in the circumstance of 0°C, it should be placed in the circumstance of above 15°C for 2 hours
In case of keeping module is in the circumstance of below -20°C, it should be placed in the circumstance of above 15°C for 3 hours.

※ Caution

When still image is displayed for a period of 20 minutes or longer (especially where W/B scale is strong. Digital pattern 13ch and/or Cross hatch pattern 09ch), there can some afterimage in the black level area

3. Adjustment items

3.1. Main PCBA Adjustments

- (1) ADC adjustment : ADC adjustment is OTP (Auto ADC)
- (2) EDID download : HDMI

- Above adjustment items can be also performed in Final Assembly if needed.
Both Board-level and Final assembly adjustment items can be check using In-Start Menu (1.Adjust Check).

3.2. Final assembly adjustment

- (1) White Balance adjustment
- (2) RS-232C functionality check
- (3) Factory Option setting per destination
- (4) Shipment mode setting (In-Stop)
- (5) GND and HI-POT test
- (6) AUDIO output check
- (7) EYE-Q function check

3.3. Appendix

- (1) Shipment conditions
- (2) Tool option menu
- (3) USB Download (S/W Update, Option and Service only)
- (4) Preset CH Information

4. MAIN PCBA Adjustments

* Download

- (1) Execute ISP program "Mstar ISP Utility" and then click "Config" tab.
- (2) Set as below, and then click "Auto Detect" and check "OK" message
If display "Error", Check connect computer, jig, and set.
- (3) Click "Connect" tab. If display "Can't ", Check connect computer, jig, and set.

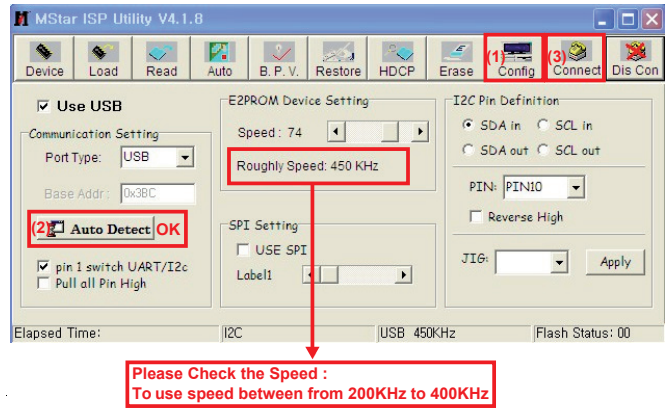

- (4) Click "Read" tab, and then load download file(XXXX.bin) by clicking "Read"

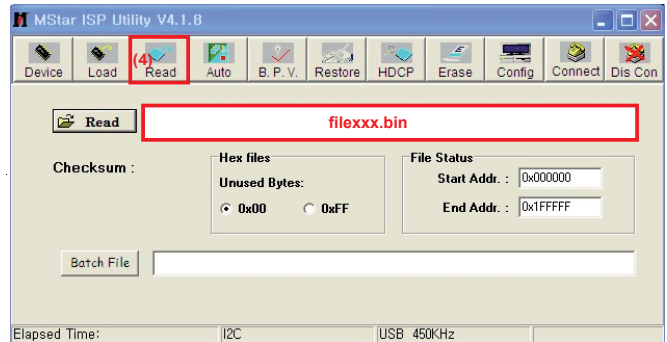

- (5) Click "Auto" tab and set as below.
- (6) Click "Run".
- (7) After downloading, check "OK" message.

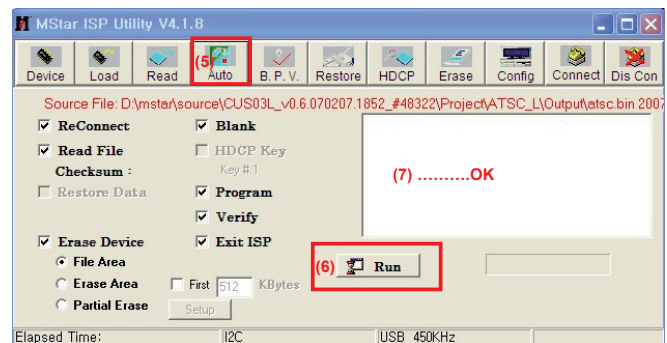

4.1. ADC Adjustment

4.1.1. Overview

- ADC adjustment is needed to find the optimum black level and gain in Analog-to-Digital device and to compensate RGB deviation.
- ADC adjustment is OTP (Auto ADC)

4.2. EDID Download

4.2.1. Overview

- It is a VESA regulation. A PC or a MNT will display an optimal resolution through information sharing without any necessity of user input. It is a realization of "Plug and Play".

4.2.2. Equipment

- (1) Since EDID data is embedded, EDID download JIG, HDMI cable is not need.
- (2) Adjust by using remote controller

4.2.3. Download method (using DFT)

※ PC(for communication through RS-232C), UART baud rate: 115200 bps

Command : aa 00 00 (Start Factory mode)

Command : ae 00 10 (Download All EDID)

Command : aa 00 90 (End of Factory mode)

4.2.4. Download method (using Service Remocon)

- (1) Press Adj. key on the Adj. R/C.
- (2) Select EDID D/L menu.
- (3) By pressing Enter key, EDID download will begin
- (4) If Download is successful, OK is display, but If Download is failure, NG is displayed.
- (5) If Download is failure, Re-try downloads.
※ Caution : When EDID Download, must remove HDMI Cable.
- (6) EDID Write confirmation

```
EDID D/L (PCM)
HDMI1 : OK
HDMI2 : OK
```

4.2.5. Models for EDID Data

	2D	
	HD / 8bit HDMI 2ea	FHD / 8bit HDMI 2ea
North America (PCM)	32LB550B-UZ 32LB560B-UZ	32LB5600-UZ 39LB5600-UZ 42LB5500-UZ 42LB5600-UZ 49LB5500-UZ 55LB5500-UZ

4.2.5. EDID DATA

4.2.5.1. North America (PCM)

4.2.5.1.1. FHD Model

- HDMI 1-FHD-8BIT (C/S : E708)
EDID Block 0, Bytes 0-127 [00H-7FH]

```

0 1 2 3 4 5 6 7 8 9 A B C D E F
-----
0 | 00 FF FF FF FF FF FF 00 1E 6D 01 00 01 01 01 01
10 | 01 18 01 03 80 A0 5A 78 0A EE 91 A3 54 4C 99 26
20 | 0F 50 54 A1 08 00 31 40 45 40 61 40 71 40 81 80
30 | 01 01 01 01 01 01 02 3A 80 18 71 38 2D 40 58 2C
40 | 45 00 40 84 63 00 00 1E 66 21 50 B0 51 00 1B 30
50 | 40 70 36 00 40 84 63 00 00 1E 00 00 00 FD 00 3A
60 | 3E 1E 53 10 00 0A 20 20 20 20 20 20 00 00 00 FC
70 | 00 4C 47 20 54 56 0A 20 20 20 20 20 20 20 01 E7

```

EDID Block 1, Bytes 128-255 [80H-FFH]

```

0 1 2 3 4 5 6 7 8 9 A B C D E F
-----
0 | 02 03 19 F1 48 90 22 20 05 04 03 02 01 23 09 57
10 | 07 67 03 0C 00 10 00 80 1E 02 3A 80 18 71 38 2D
20 | 40 58 2C 04 05 40 84 63 00 00 1E 01 1D 80 18 71
30 | 1C 16 20 58 2C 25 00 40 84 63 00 00 9E 01 1D 00
40 | 72 51 D0 1E 20 6E 28 55 00 40 84 63 00 00 1E 8C
50 | 0A D0 8A 20 E0 2D 10 10 3E 96 00 40 84 63 00 00
60 | 18 00 00 00 00 00 00 00 00 00 00 00 00 00 00 00
70 | 00 00 00 00 00 00 00 00 00 00 00 00 00 00 00 08

```

- HDMI 2-FHD-8BIT (C/S : E7F8)
EDID Block 0, Bytes 0-127 [00H-7FH]

```

0 1 2 3 4 5 6 7 8 9 A B C D E F
-----
0 | 00 FF FF FF FF FF FF 00 1E 6D 01 00 01 01 01 01
10 | 01 18 01 03 80 A0 5A 78 0A EE 91 A3 54 4C 99 26
20 | 0F 50 54 A1 08 00 31 40 45 40 61 40 71 40 81 80
30 | 01 01 01 01 01 01 02 3A 80 18 71 38 2D 40 58 2C
40 | 45 00 40 84 63 00 00 1E 66 21 50 B0 51 00 1B 30
50 | 40 70 36 00 40 84 63 00 00 1E 00 00 00 FD 00 3A
60 | 3E 1E 53 10 00 0A 20 20 20 20 20 20 00 00 00 FC
70 | 00 4C 47 20 54 56 0A 20 20 20 20 20 20 20 01 E7

```

EDID Block 1, Bytes 128-255 [80H-FFH]

```

0 1 2 3 4 5 6 7 8 9 A B C D E F
-----
0 | 02 03 19 F1 48 90 22 20 05 04 03 02 01 23 09 57
10 | 07 67 03 0C 00 20 00 80 1E 02 3A 80 18 71 38 2D
20 | 40 58 2C 04 05 40 84 63 00 00 1E 01 1D 80 18 71
30 | 1C 16 20 58 2C 25 00 40 84 63 00 00 9E 01 1D 00
40 | 72 51 D0 1E 20 6E 28 55 00 40 84 63 00 00 1E 8C
50 | 0A D0 8A 20 E0 2D 10 10 3E 96 00 40 84 63 00 00
60 | 18 00 00 00 00 00 00 00 00 00 00 00 00 00 00 00
70 | 00 00 00 00 00 00 00 00 00 00 00 00 00 00 00 F8

```

4.2.5.1.2. HD Model

■ HDMI 1-HD (C/S : 6F08)

EDID Block 0, Bytes 0-127 [00H-7FH]

```

0 1 2 3 4 5 6 7 8 9 A B C D E F
-----
0 | 00 FF FF FF FF FF FF 00 1E 6D 01 00 01 01 01 01
10 | 01 18 01 03 80 A0 5A 78 0A EE 91 A3 54 4C 99 26
20 | 0F 50 54 A1 08 00 31 40 45 40 61 40 71 40 01 01
30 | 01 01 01 01 01 01 66 21 50 B0 51 00 1B 30 40 70
40 | 36 00 40 84 63 00 00 1E 64 19 00 40 41 00 26 30
50 | 18 88 36 00 40 84 63 00 00 1E 00 00 00 FD 00 3A
60 | 3E 1E 53 10 00 0A 20 20 20 20 20 20 00 00 00 FC
70 | 00 4C 47 20 54 56 0A 20 20 20 20 20 20 01 6F
    
```

EDID Block 1, Bytes 128-255 [80H-FFH]

```

0 1 2 3 4 5 6 7 8 9 A B C D E F
-----
0 | 02 03 19 F1 48 10 22 20 05 84 03 02 01 23 09 57
10 | 07 67 03 0C 00 10 00 80 1E 02 3A 80 18 71 38 2D
20 | 40 58 2C 04 05 40 84 63 00 00 1E 01 1D 80 18 71
30 | 1C 16 20 58 2C 25 00 40 84 63 00 00 9E 01 1D 00
40 | 72 51 D0 1E 20 6E 28 55 00 40 84 63 00 00 1E 8C
50 | 0A D0 8A 20 E0 2D 10 10 3E 96 00 40 84 63 00 00
60 | 18 00 00 00 00 00 00 00 00 00 00 00 00 00 00
70 | 00 00 00 00 00 00 00 00 00 00 00 00 00 00 08
    
```

■ HDMI 2-HD (C/S : 6FF8)

EDID Block 0, Bytes 0-127 [00H-7FH]

```

0 1 2 3 4 5 6 7 8 9 A B C D E F
-----
0 | 00 FF FF FF FF FF FF 00 1E 6D 01 00 01 01 01 01
10 | 01 18 01 03 80 A0 5A 78 0A EE 91 A3 54 4C 99 26
20 | 0F 50 54 A1 08 00 31 40 45 40 61 40 71 40 01 01
30 | 01 01 01 01 01 01 66 21 50 B0 51 00 1B 30 40 70
40 | 36 00 40 84 63 00 00 1E 64 19 00 40 41 00 26 30
50 | 18 88 36 00 40 84 63 00 00 1E 00 00 00 FD 00 3A
60 | 3E 1E 53 10 00 0A 20 20 20 20 20 20 00 00 00 FC
70 | 00 4C 47 20 54 56 0A 20 20 20 20 20 20 01 6F
    
```

EDID Block 1, Bytes 128-255 [80H-FFH]

```

0 1 2 3 4 5 6 7 8 9 A B C D E F
-----
0 | 02 03 19 F1 48 10 22 20 05 84 03 02 01 23 09 57
10 | 07 67 03 0C 00 20 00 80 1E 02 3A 80 18 71 38 2D
20 | 40 58 2C 04 05 40 84 63 00 00 1E 01 1D 80 18 71
30 | 1C 16 20 58 2C 25 00 40 84 63 00 00 9E 01 1D 00
40 | 72 51 D0 1E 20 6E 28 55 00 40 84 63 00 00 1E 8C
50 | 0A D0 8A 20 E0 2D 10 10 3E 96 00 40 84 63 00 00
60 | 18 00 00 00 00 00 00 00 00 00 00 00 00 00 00
70 | 00 00 00 00 00 00 00 00 00 00 00 00 00 00 F8
    
```

4.2.5.2. AC3 EDID Data

4.2.5.2.1. FHD Model

■ HDMI 1-FHD-8BIT (C/S : E796)

EDID Block 0, Bytes 0-127 [00H-7FH]

```

0 1 2 3 4 5 6 7 8 9 A B C D E F
-----
0 | 00 FF FF FF FF FF FF 00 1E 6D 01 00 01 01 01 01
10 | 01 18 01 03 80 A0 5A 78 0A EE 91 A3 54 4C 99 26
20 | 0F 50 54 A1 08 00 31 40 45 40 61 40 71 40 81 80
30 | 01 01 01 01 01 01 02 3A 80 18 71 38 2D 40 58 2C
40 | 45 00 40 84 63 00 00 1E 66 21 50 B0 51 00 1B 30
50 | 40 70 36 00 40 84 63 00 00 1E 00 00 00 FD 00 3A
60 | 3E 1E 53 10 00 0A 20 20 20 20 20 20 00 00 00 FC
70 | 00 4C 47 20 54 56 0A 20 20 20 20 20 20 01 E7
    
```

EDID Block 1, Bytes 128-255 [80H-FFH]

```

0 1 2 3 4 5 6 7 8 9 A B C D E F
-----
0 | 02 03 1C F1 48 90 22 20 05 04 03 02 01 26 15 07
10 | 50 09 57 07 67 03 0C 00 10 00 80 1E 02 3A 80 18
20 | 71 38 2D 40 58 2C 04 05 40 84 63 00 00 1E 01 1D
30 | 80 18 71 1C 16 20 58 2C 25 00 40 84 63 00 00 9E
40 | 01 1D 00 72 51 D0 1E 20 6E 28 55 00 40 84 63 00
50 | 00 1E 8C 0A D0 8A 20 E0 2D 10 10 3E 96 00 40 84
60 | 63 00 00 18 00 00 00 00 00 00 00 00 00 00 00
70 | 00 00 00 00 00 00 00 00 00 00 00 00 00 00 96
    
```

■ HDMI 2-FHD-8BIT (C/S : E786)

EDID Block 0, Bytes 0-127 [00H-7FH]

```

0 1 2 3 4 5 6 7 8 9 A B C D E F
-----
0 | 00 FF FF FF FF FF FF 00 1E 6D 01 00 01 01 01 01
10 | 01 18 01 03 80 A0 5A 78 0A EE 91 A3 54 4C 99 26
20 | 0F 50 54 A1 08 00 31 40 45 40 61 40 71 40 81 80
30 | 01 01 01 01 01 01 02 3A 80 18 71 38 2D 40 58 2C
40 | 45 00 40 84 63 00 00 1E 66 21 50 B0 51 00 1B 30
50 | 40 70 36 00 40 84 63 00 00 1E 00 00 00 FD 00 3A
60 | 3E 1E 53 10 00 0A 20 20 20 20 20 20 00 00 00 FC
70 | 00 4C 47 20 54 56 0A 20 20 20 20 20 20 01 E7
    
```

EDID Block 1, Bytes 128-255 [80H-FFH]

```

0 1 2 3 4 5 6 7 8 9 A B C D E F
-----
0 | 02 03 1C F1 48 90 22 20 05 04 03 02 01 26 15 07
10 | 50 09 57 07 67 03 0C 00 20 00 80 1E 02 3A 80 18
20 | 71 38 2D 40 58 2C 04 05 40 84 63 00 00 1E 01 1D
30 | 80 18 71 1C 16 20 58 2C 25 00 40 84 63 00 00 9E
40 | 01 1D 00 72 51 D0 1E 20 6E 28 55 00 40 84 63 00
50 | 00 1E 8C 0A D0 8A 20 E0 2D 10 10 3E 96 00 40 84
60 | 63 00 00 18 00 00 00 00 00 00 00 00 00 00 00
70 | 00 00 00 00 00 00 00 00 00 00 00 00 00 00 86
    
```

4.2.5.2.2. HD Model

- HDMI 1-HD (C/S : 6F96)
EDID Block 0, Bytes 0-127 [00H-7FH]

	0	1	2	3	4	5	6	7	8	9	A	B	C	D	E	F
0		00	FF	FF	FF	FF	FF	00	1E	6D	01	00	01	01	01	01
10		01	18	01	03	80	A0	5A	78	0A	EE	91	A3	54	4C	99
20		0F	50	54	A1	08	00	31	40	45	40	61	40	71	40	01
30		01	01	01	01	01	01	66	21	50	B0	51	00	1B	30	40
40		36	00	40	84	63	00	00	1E	64	19	00	40	41	00	26
50		18	88	36	00	40	84	63	00	00	1E	00	00	00	FD	00
60		3E	1E	53	10	00	0A	20	20	20	20	20	20	00	00	00
70		00	4C	47	20	54	56	0A	20	20	20	20	20	20	01	6F

EDID Block 1, Bytes 128-255 [80H-FFH]

	0	1	2	3	4	5	6	7	8	9	A	B	C	D	E	F
0		02	03	1C	F1	48	10	22	20	05	84	03	02	01	26	15
10		50	09	57	07	67	03	0C	00	10	00	80	1E	02	3A	80
20		71	38	2D	40	58	2C	04	05	40	84	63	00	00	1E	01
30		80	18	71	1C	16	20	58	2C	25	00	40	84	63	00	00
40		01	1D	00	72	51	D0	1E	20	6E	28	55	00	40	84	63
50		00	1E	8C	0A	D0	8A	20	E0	2D	10	10	3E	96	00	40
60		63	00	00	18	00	00	00	00	00	00	00	00	00	00	00
70		00	00	00	00	00	00	00	00	00	00	00	00	00	00	96

- HDMI 2-HD (C/S : 6F86)
EDID Block 0, Bytes 0-127 [00H-7FH]

	0	1	2	3	4	5	6	7	8	9	A	B	C	D	E	F
0		00	FF	FF	FF	FF	FF	00	1E	6D	01	00	01	01	01	01
10		01	18	01	03	80	A0	5A	78	0A	EE	91	A3	54	4C	99
20		0F	50	54	A1	08	00	31	40	45	40	61	40	71	40	01
30		01	01	01	01	01	01	66	21	50	B0	51	00	1B	30	40
40		36	00	40	84	63	00	00	1E	64	19	00	40	41	00	26
50		18	88	36	00	40	84	63	00	00	1E	00	00	00	FD	00
60		3E	1E	53	10	00	0A	20	20	20	20	20	20	00	00	00
70		00	4C	47	20	54	56	0A	20	20	20	20	20	20	01	6F

EDID Block 1, Bytes 128-255 [80H-FFH]

	0	1	2	3	4	5	6	7	8	9	A	B	C	D	E	F
0		02	03	1C	F1	48	10	22	20	05	84	03	02	01	26	15
10		50	09	57	07	67	03	0C	00	20	00	80	1E	02	3A	80
20		71	38	2D	40	58	2C	04	05	40	84	63	00	00	1E	01
30		80	18	71	1C	16	20	58	2C	25	00	40	84	63	00	00
40		01	1D	00	72	51	D0	1E	20	6E	28	55	00	40	84	63
50		00	1E	8C	0A	D0	8A	20	E0	2D	10	10	3E	96	00	40
60		63	00	00	18	00	00	00	00	00	00	00	00	00	00	00
70		00	00	00	00	00	00	00	00	00	00	00	00	00	00	86

4.3. Tool Option Input

- Input Model Tool Option according to BOM

5. Final Assembly Adjustment

5.1. White Balance Adjustment

5.1.1. Overview

5.1.1.1. W/B adj. Objective & How-it-works

- (1) Objective: To reduce each Panel's W/B deviation
- (2) How-it-works: When R/G/B gain in the OSD is at 192, it means the panel is at its Full Dynamic Range. In order to prevent saturation of Full Dynamic range and data, one of R/G/B is fixed at 192, and the other two is lowered to find the desired value.
- (3) Adj. condition: normal temperature
 - Surrounding Temperature: 25±5 °C
 - Warm-up time: About 5 Min
 - Surrounding Humidity: 20% ~ 80%
 - Before White balance adjustment, Keep power on status, don't power off

5.1.1.2. Adj. condition and cautionary items

- (1) Lighting condition in surrounding area surrounding lighting should be lower 10 lux. Try to isolate adj. area into dark surrounding.
- (2) Probe location: Color Analyzer (CA-210) probe should be within 10cm and perpendicular of the module surface (80°~ 100°)
- (3) Aging time
 - After Aging Start, Keep the Power ON status during 5 Minutes.
 - In case of LCD, Back-light on should be checked using no signal or Full-white pattern.

5.1.2. Equipment

- (1) Color Analyzer: CA-210 (NCG: CH 9 / WCG: CH12 / LED: CH14)
- (2) Adj. Computer(During auto adj., RS-232C protocol is needed)
- (3) Adjust Remocon
- (4) Video Signal Generator MSPG-925F 720p/204-Gray (Model:217, Pattern:49)
 - Only when internal pattern is not available
 - ※ Color Analyzer Matrix should be calibrated using CS-1000

5.1.3. Equipment connection

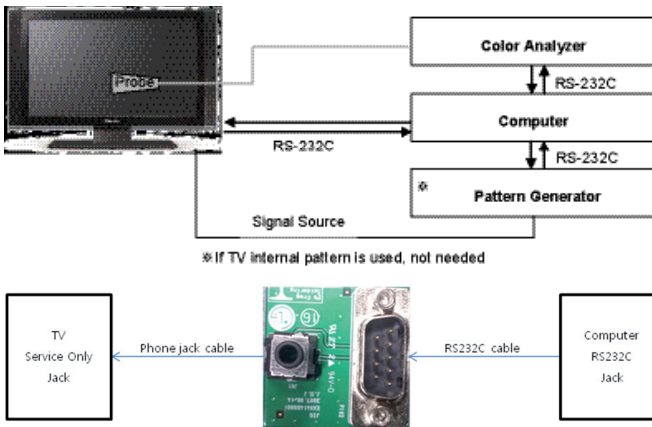

5.1.4. Adjustment Command (Protocol)

(1) RS-232C Command used during auto-adj

RS-232C COMMAND			Explanation
CMD	DATA	ID	
Wb	00	00	Begin White Balance adj.
Wb	00	ff	End White Balance adj. (internal pattern disappears)

(2) Adjustment Map

	Adj. item	Command (lower case ASCII)		Data Range (Hex.)		Default (Decimal)
		CMD1	CMD2	MIN	MAX	MAX
Cool	R Gain	j	g	00	C0	172
	G Gain	j	h	00	C0	172
	B Gain	j	i	00	C0	192
	R Cut					128
	G Cut					128
	B Cut					128
Medium	R Gain	j	a	00	C0	192
	G Gain	j	b	00	C0	192
	B Gain	j	c	00	C0	192
	R Cut					128
	G Cut					128
	B Cut					128
Warm	R Gain	j	d	00	C0	192
	G Gain	j	e	00	C0	192
	B Gain	j	f	00	C0	172
	R Cut					128
	G Cut					128
	B Cut					128

5.1.5. Adjustment method

5.1.5.1. Auto WB calibration

- (1) Set TV in ADJ mode using P-ONLY key (or POWER ON key)
 - (2) Place optical probe on the center of the display
- It need to check probe condition of zero calibration before adjustment.
 - (3) Connect RS-232C Cable
 - (4) Select mode in ADJ Program and begin a adjustment.
 - (5) When WB adjustment is completed with OK message, check adjustment status of pre-set mode (Cool, Medium, Warm)
 - (6) Remove probe and RS-232C cable.
- ※ W/B Adj. must begin as start command "wb 00 00", and finish as end command "wb 00 ff", and Adj. offset if need.

5.1.5.2. Manual adj. method

- (1) Set TV in Adj. mode using POWER ON
- (2) Zero Calibrate the probe of Color Analyzer, then place it on the center of LCD module within 10cm of the surface..
- (3) Press ADJ key -> EZ adjust using adj. R/C -> 6. White-Balance then press the cursor to the right (KEY▶).
(When KEY(▶) is pressed 204 Gray(80IRE) internal pattern will be displayed)
- (4) One of R Gain / G Gain / B Gain should be fixed at 192, and the rest will be lowered to meet the desired value.
- (5) Adj. is performed in COOL, MEDIUM, WARM 3 modes of color temperature.

※ CASE

First adjust the coordinate far away from the target value(x, y).

(1) $x, y > \text{target}$

i) Decrease the R, G.

(2) $x, y < \text{target}$

i) First decrease the B gain,

ii) Decrease the one of the others.

(3) $x > \text{target}, y < \text{target}$

i) First decrease B, so make y a little more than the target.

ii) Adjust x value by decreasing the R

(4) $x < \text{target}, y > \text{target}$

i) First decrease B, so make x a little more than the target.

ii) Adjust x value by decreasing the G

▶ How to adjust

(1) Fix G gain at least 172

Adjust R, B Gain (In Case of Mostly Blue Gain Saturation)

(2) When R or B Gain > 255, Release Fixed G Gain and Readjust

※ CASE Medium / Warm

First adjust the coordinate far away from the target value(x, y).

(1) $x, y > \text{target}$

i) Decrease the R, G.

(2) $x, y < \text{target}$

i) First decrease the B gain,

ii) Decrease the one of the others.

(3) $x > \text{target}, y < \text{target}$

i) First decrease B, so make y a little more than the target.

ii) Adjust x value by decreasing the R

(4) $x < \text{target}, y > \text{target}$

i) First decrease B, so make x a little more than the target.

ii) Adjust x value by decreasing the G

5.1.6. Reference

(White Balance Adj. coordinate and color temperature)

- Luminance: 204 Gray, 80IRE
- ** (normal line) Model : For LGD (LB56xx, LB55xx)
- Standard color coordinate and temperature using CA-210(CH-14) – by aging time

H/R Time(Min)		Cool		Medium		Warm	
		x	y	x	x	y	x
		271	270	286	289	313	329
1	0-2	281	285	296	304	323	344
2	3-5	280	284	295	303	322	343
3	6-9	279	282	294	301	321	341
4	10-19	277	279	292	288	319	338
5	20-35	275	275	290	294	317	334
6	36-49	273	273	288	292	315	332
7	50-79	272	272	287	291	314	331
8	80-119	271	270	286	289	313	329
9	Over 120	271	270	286	289	313	329

** (aging chamber) Model : For LGD (LB56xx, LB55xx)

- Standard color coordinate and temperature using CA-210(CH-14) – by aging time

H/R Time(Min)		Cool		Medium		Warm	
		x	y	x	x	y	x
		271	270	286	289	313	329
1	0-5	280	285	295	304	319	340
2	6-10	276	280	291	299	315	335
3	11-20	272	275	287	294	311	330
4	21-30	269	272	284	291	308	327
5	31-40	267	268	282	287	306	323
6	41-50	266	265	281	284	305	320
7	51-80	265	263	280	282	304	318
8	81-119	264	261	279	280	303	316
9	Over 120	264	260	279	279	303	315

**For INX,AUO,SHARP,CSOT Module.(In the case of , the color temperature spec of cool mode is 13000K)

H/R Time(Min)		Cool		Medium		Warm	
		x	y	x	x	y	x
spec	271	270	286	289	313	329	329
target	276	277	291	296	318	336	340

5.2. Option selection per country

5.2.1. Overview

- (1) Tool option selection is only done for models in Non-USA North America due to rating
- (2) Applied model: LA32B Chassis applied to CANADA and MEXICO

5.2.2. Country Group selection

- (1) Press ADJ key on the Adj. R/C, and then select Country Group Menu
- (2) Depending on destination, select US, then on the lower Country option, select US, CA, MX.
Selection is done using +, - KEY
- (3) Using DFT(Auto)
※ PC (for communication through RS-232C) -> UART Baud rate : 115200 bps
Command : ah 00 00 DATA(Area Number(hexadecimal))

ITEM	DATA(Area Number)	AREA
AREA OPTION1	0	USA
	1	CANADA
	2	MEXICO

5.2.3. Tool Option inspection

- Press Adj. key on the Adj. R/C, then select Tool option

Model	Module	Tool option1	Tool option2	Tool option3	Tool option4
32LB550B-UZ	LGD	784	13314	41036	20544
32LB560B-UZ	SHARP	13074	9218	41036	20544
32LB550B-UZ	SHARP	13074	13314	41036	20544
42LB5500-UZ	LGD	1552	5126	41036	24640
42LB5500-UZ	AUO	9744	5126	41036	24640
42LB5600-UZ	LGD	1552	1030	41036	24640
42LB5600-UZ	AUO	9744	1030	41036	24640
39LB5600-UZ	INX	17682	1030	41036	24640
49LB5500-UZ	LGD	2064	5126	41036	24640
55LB5500-UZ	LGD	2576	5126	41036	24640
55LB5500-UZ	BOE	23058	5126	41036	24640
32LB550B-UZ	BOE	21266	13314	41036	24640
32LB5600-UZ	LGD	784	1026	41036	24640
32LB560B-UZ	LGD	784	9218	41036	20544

※ Tool option can be reconstructed by Software

5.3. Ship-out mode check (In-stop)

- After final inspection, press In-Stop key of the Adj. R/C and check that the unit goes to Stand-by mode

6. GND and HI-POT Test

6.1. GND & HI-POT auto-check preparation

- (1) Check the POWER CABLE and SIGNAL CABLE insertion condition

6.2. GND & HI-POT auto-check

- (1) Pallet moves in the station. (POWER CORD / AV CORD is tightly inserted)
- (2) Connect the AV JACK Tester.
- (3) Controller (GWS103-4) on.
- (4) GND Test (Auto)
 - If Test is failed, Buzzer operates.
 - If Test is passed, execute next process (Hi-pot test). (Remove A/V CORD from A/V JACK BOX)
- (5) HI-POT test (Auto)
 - If Test is failed, Buzzer operates.
 - If Test is passed, GOOD Lamp on and move to next process automatically

6.3. Checkpoint

- (1) Test voltage
 - GND: 1.5KV/min at 100mA
 - SIGNAL: 3KV/min at 100mA
- (2) TEST time: 1 second
- (3) TEST POINT
 - GND Test = POWER CORD GND and SIGNAL CABLE GND.
 - Hi-pot Test = POWER CORD GND and LIVE & NEUTRAL.
- (4) LEAKAGE CURRENT: At 0.5mA

7. AUDIO output check

7.1. Audio input condition

- (1) RF input: Mono, 1KHz sine wave signal, 100% Modulation
- (2) CVBS, Component: 1KHz sine wave signal (0.4Vrms)

7.2. Specification

No	Item	Min	Typ	Max	Unit	Remark
1	Audio practical max Output, L/R (Distortion=10% max Output)	4.5	5.0	6.0	W	(1) Measurement condition - EQ/AVL/Clear Voice: Off (2) Speaker (8Ω Impedance) LB55 Series
		6.0	6.3	6.9	Vrms	
		9.0	10.9	12.0	W	(1) Measurement condition - EQ/AVL/Clear Voice: Off (2) Speaker (8Ω Impedance) LB56 Series
		8.5	9.3	9.8	Vrms	

* USB S/W Download (option, Service only)

- (1) Put the USB Stick to the USB socket.
- (2) Automatically detecting update file in USB Stick.
 - If your downloaded program version in USB Stick is Low, it didn't work. But your downloaded version is High, USB data is automatically detecting
- (3) Show the message "Copying files from memory"

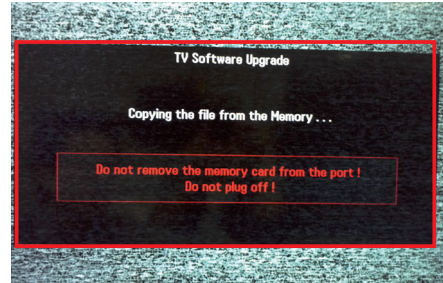

- (4) Updating is starting.

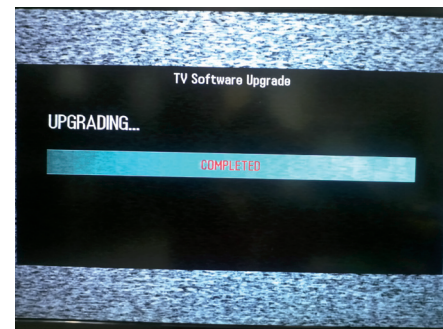
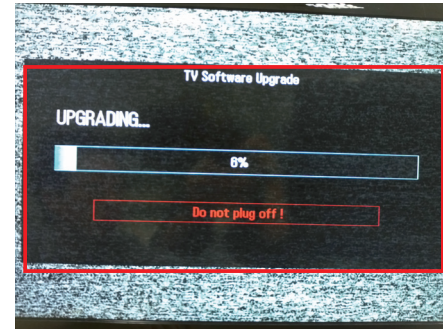

- (5) After updating is complete, The TV will restart automatically.
- (6) If TV turns on, check your updated version and Tool option. (refer to the next page about tool option)

* If downloading version is higher than your TV have, TV can lost all channel data. In this case, you have to channel recover. If all channel data is cleared, you didn't have a DTV/ATV test on production line.

※ After downloading, TOOL OPTION setting is needed again.

- (1) Push "IN-START" key in service remote controller.
- (2) Select "Tool Option 1" and Push "OK" button.
- (3) Punch in the number. (Each model has their number.)

TROUBLE SHOOTING

1. Power-up boot check

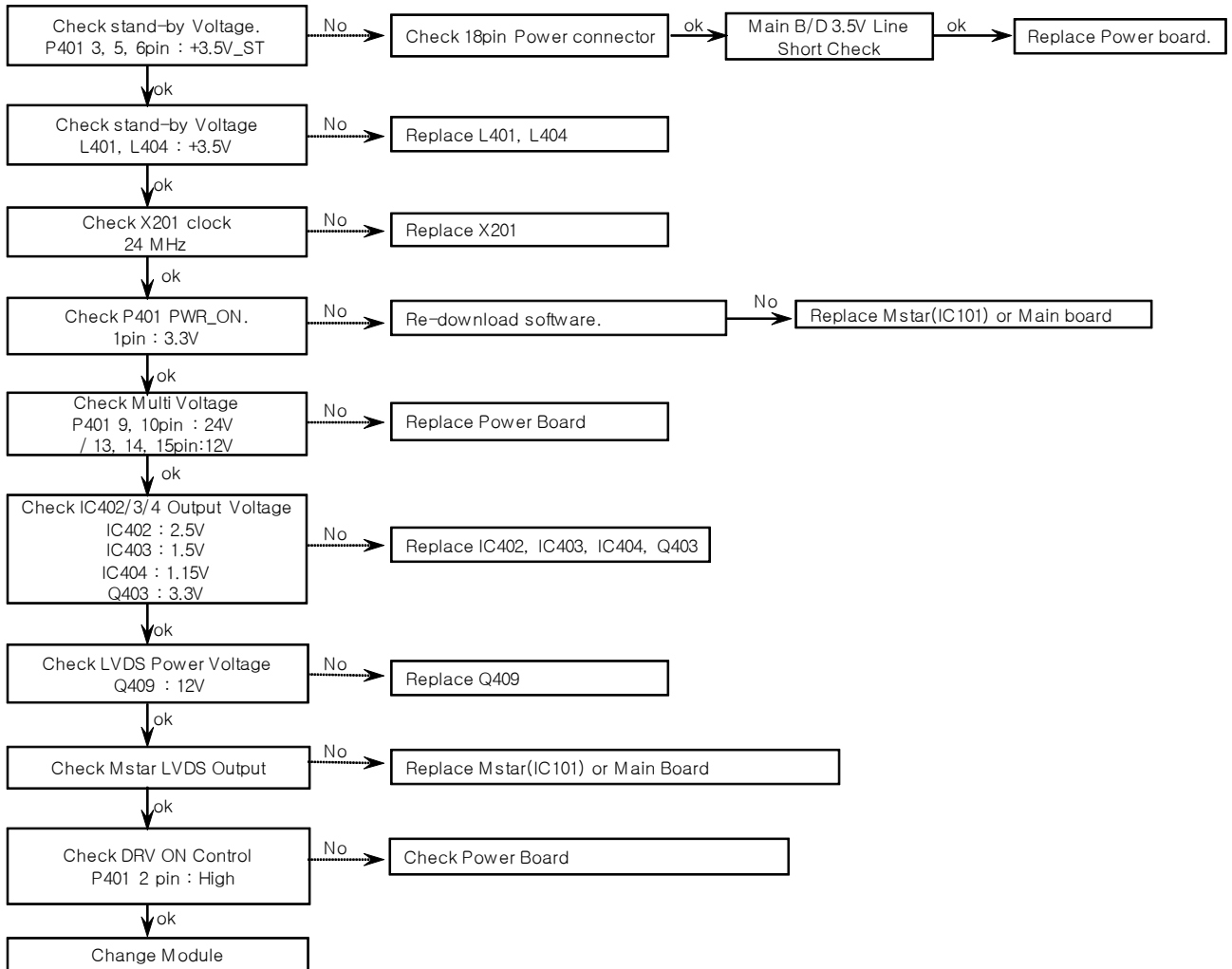

2. Digital/Analog TV Video

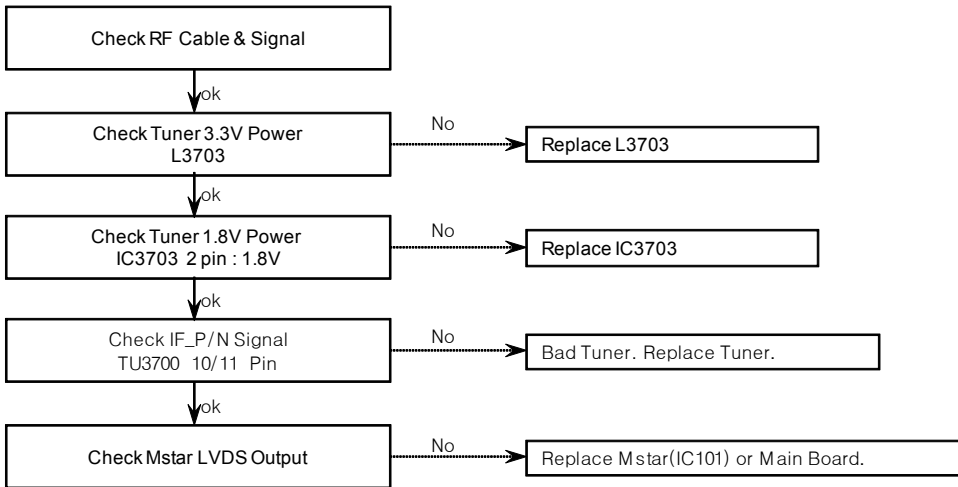

3. AV Video

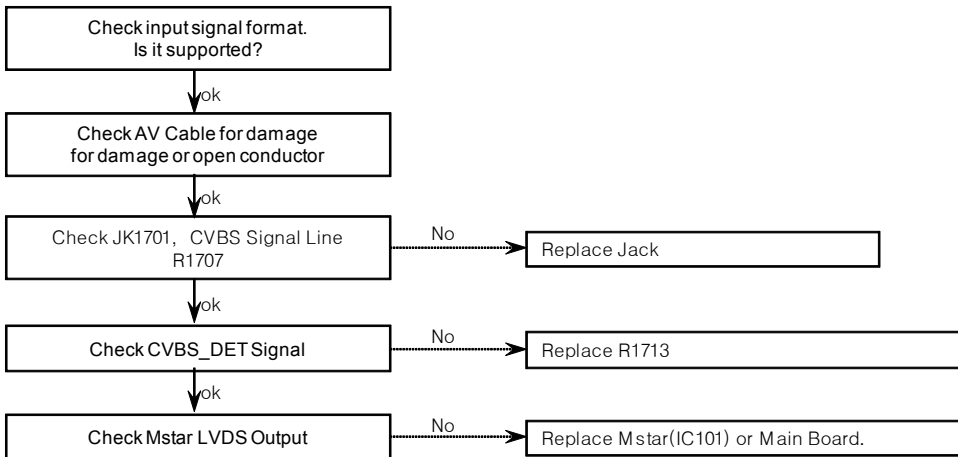

4. Component Video

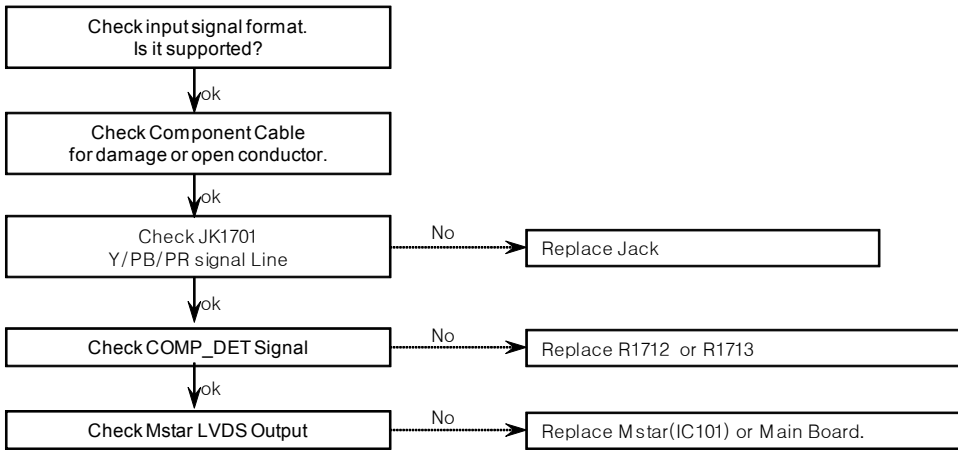

5. HDMI Video

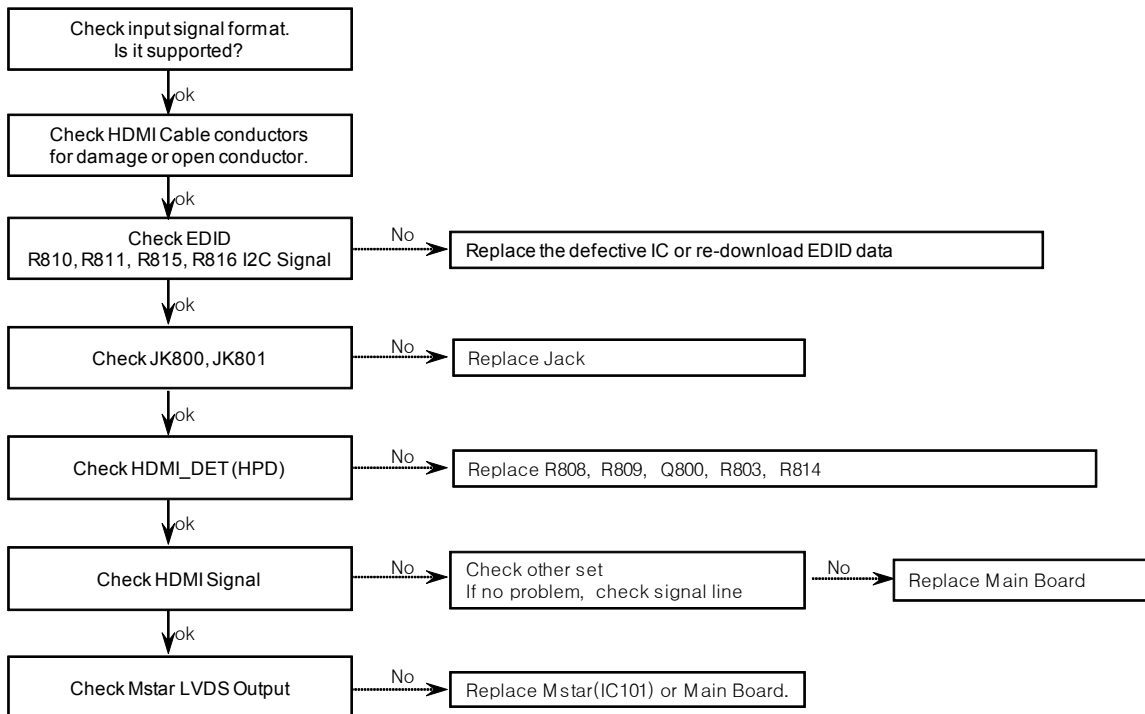

6. MHL Video

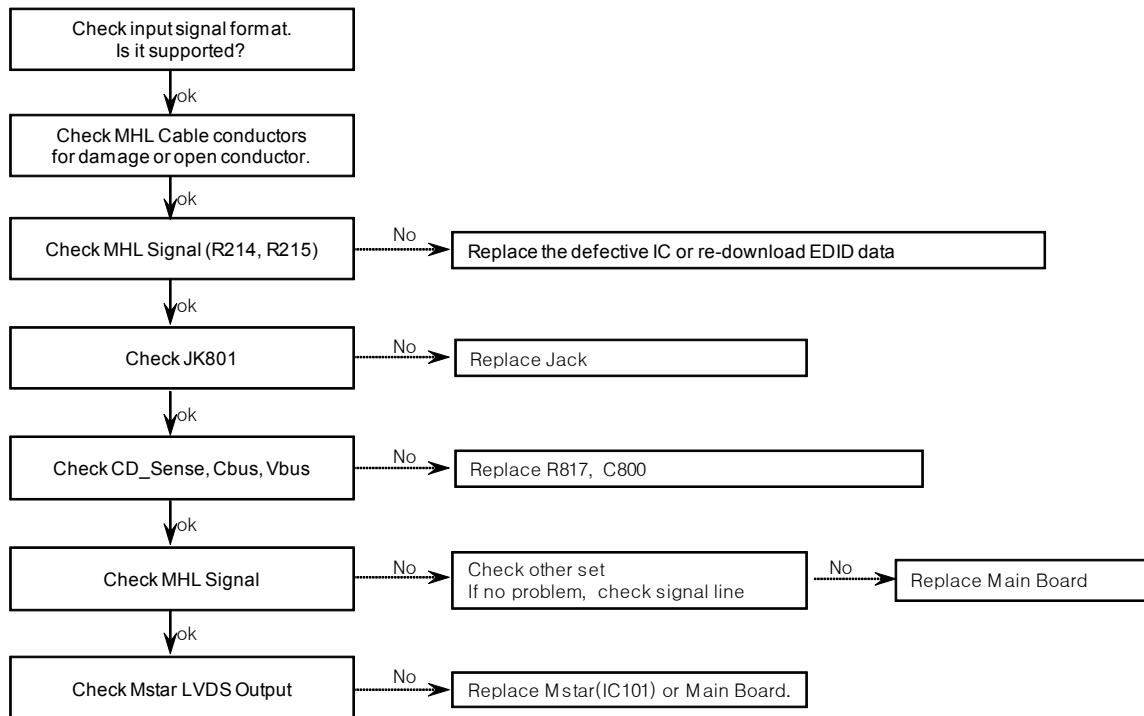

7. All Source Audio

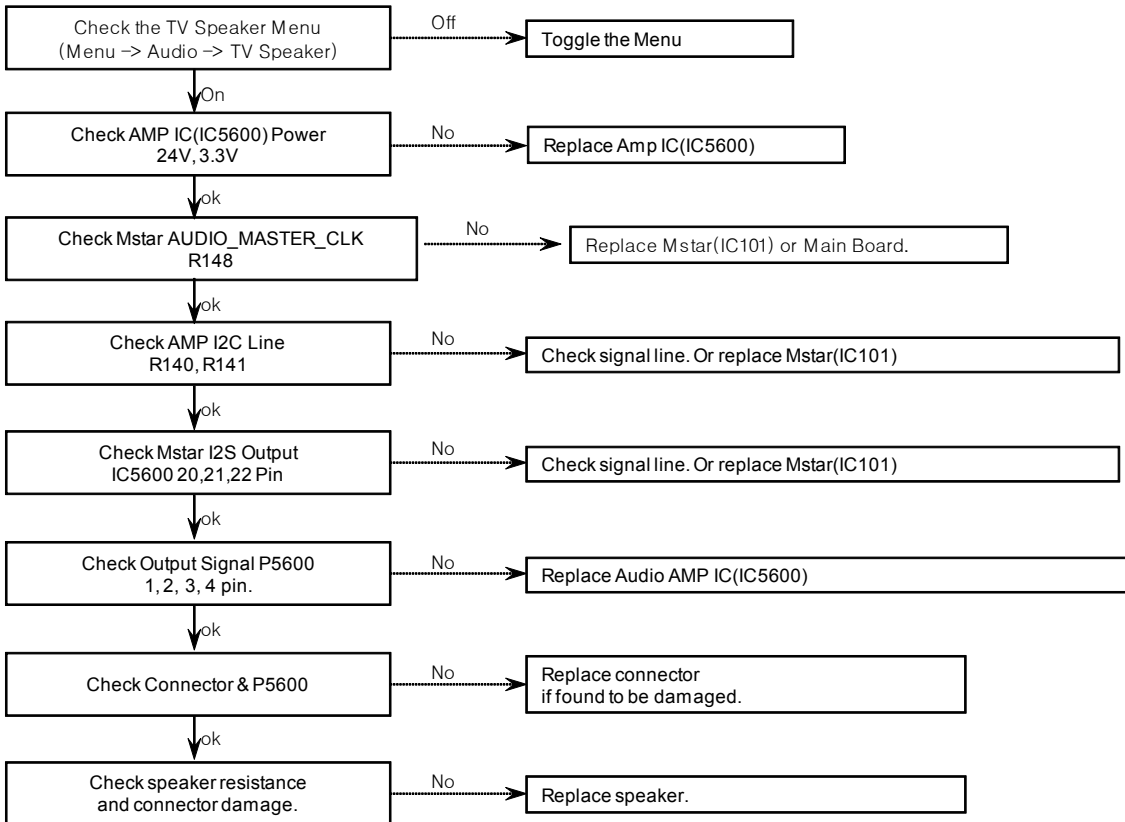

8. Digital/Analog TV Audio

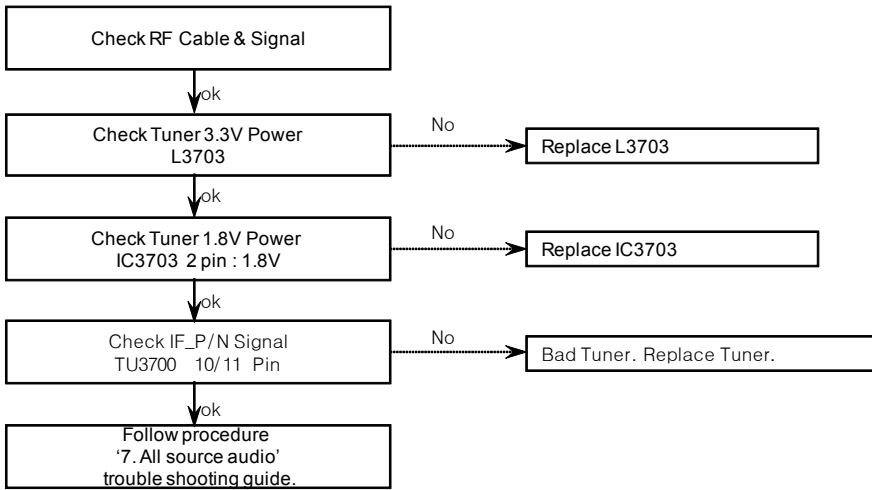

9. AV Audio

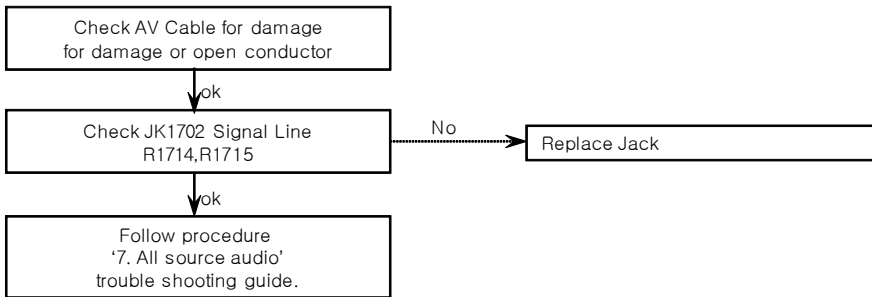

10. Component Audio

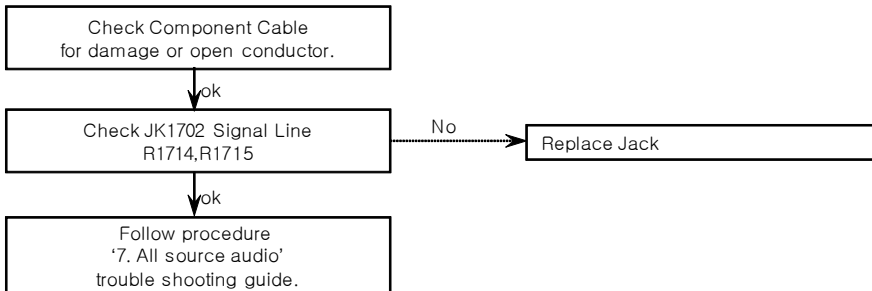

BLOCK DIAGRAM

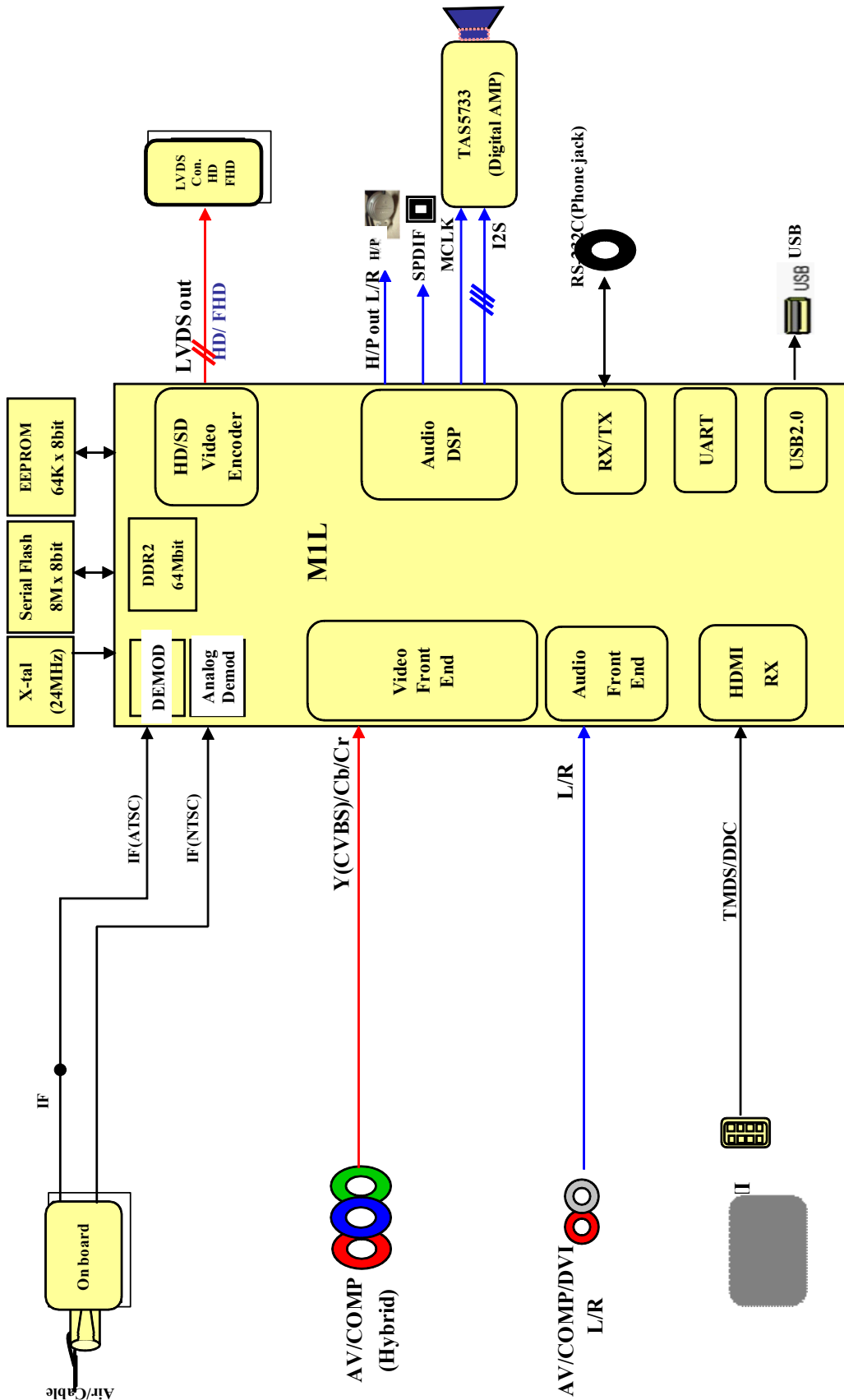

EXPLODED VIEW

IMPORTANT SAFETY NOTICE

Many electrical and mechanical parts in this chassis have special safety-related characteristics. These parts are identified by Δ in the Schematic Diagram and EXPLODED VIEW. It is essential that these special safety parts should be replaced with the same components as recommended in this manual to prevent X-RADIATION, Shock, Fire, or other Hazards. Do not modify the original design without permission of manufacturer.

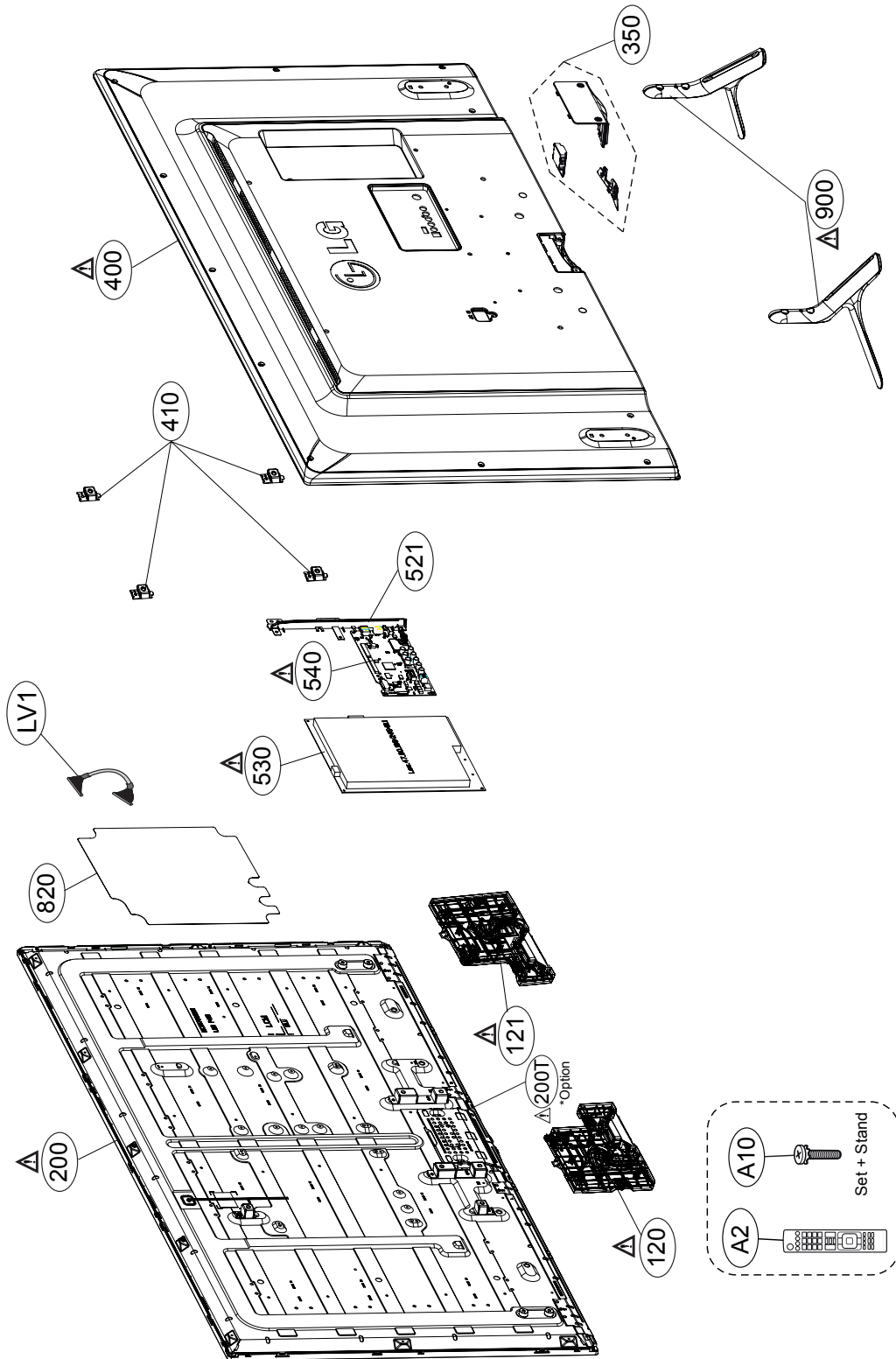

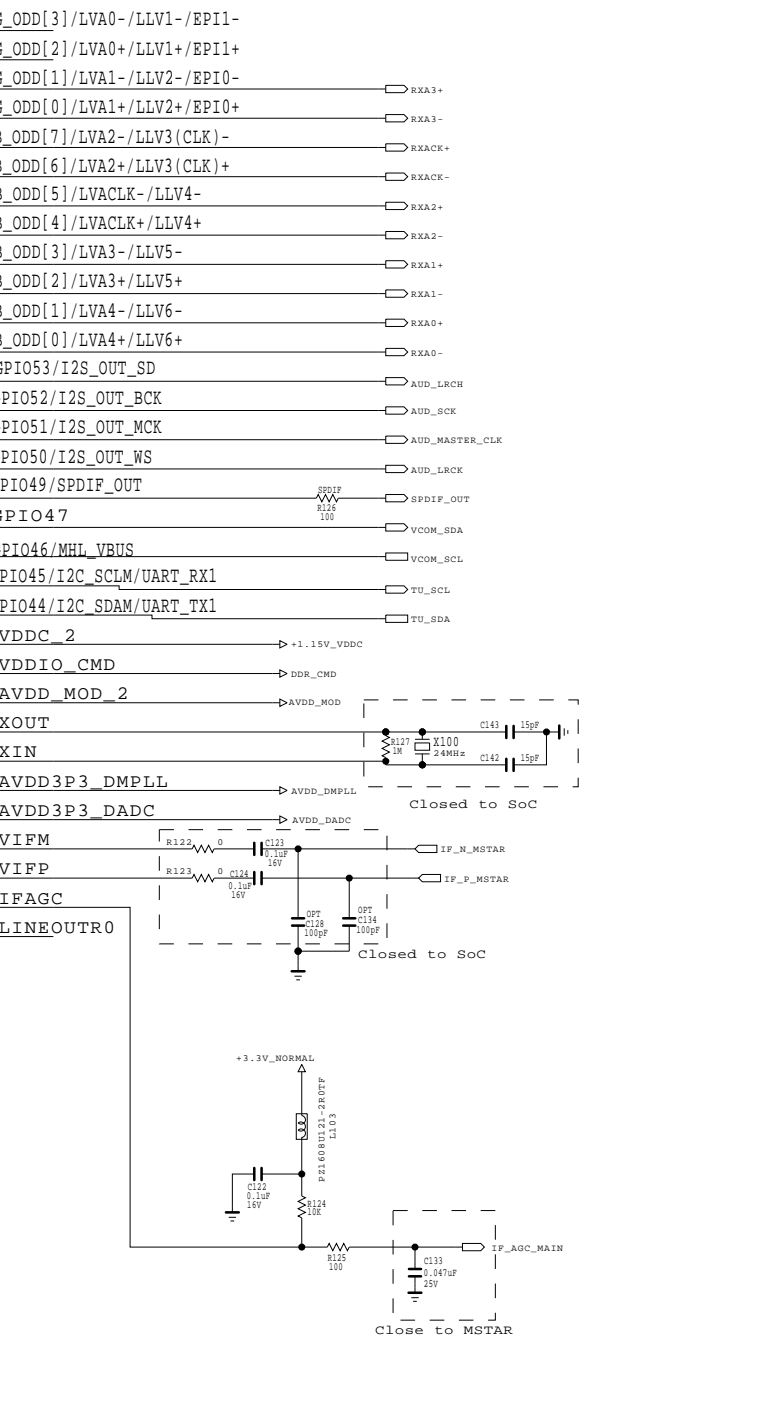
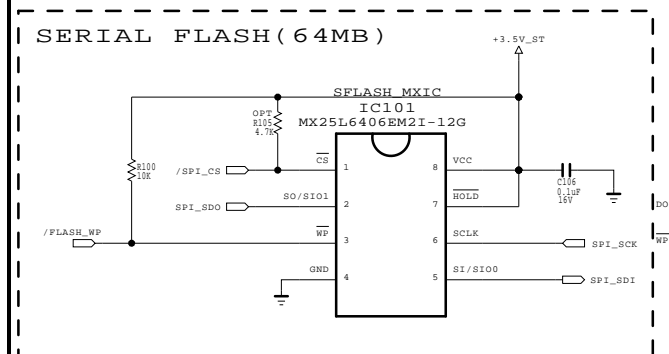
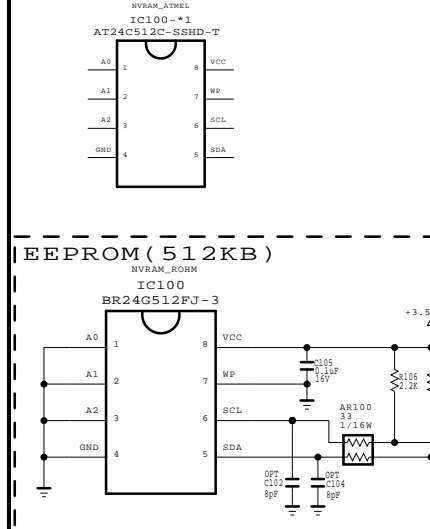
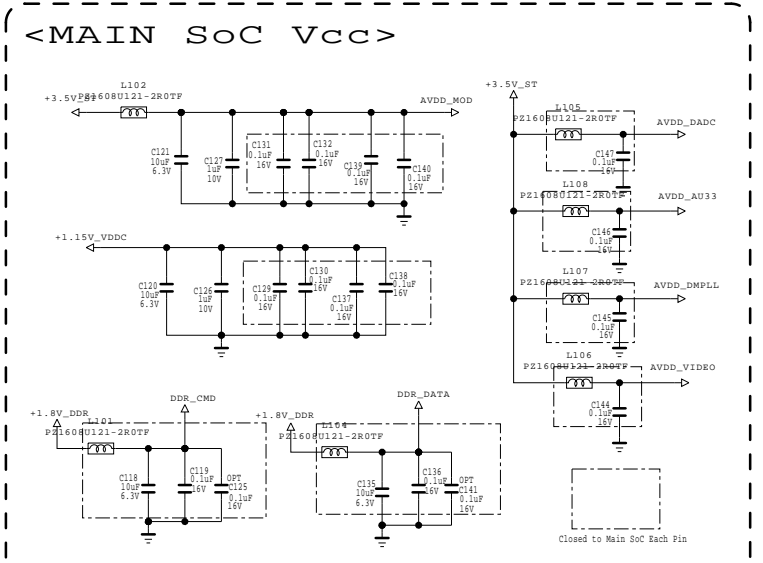
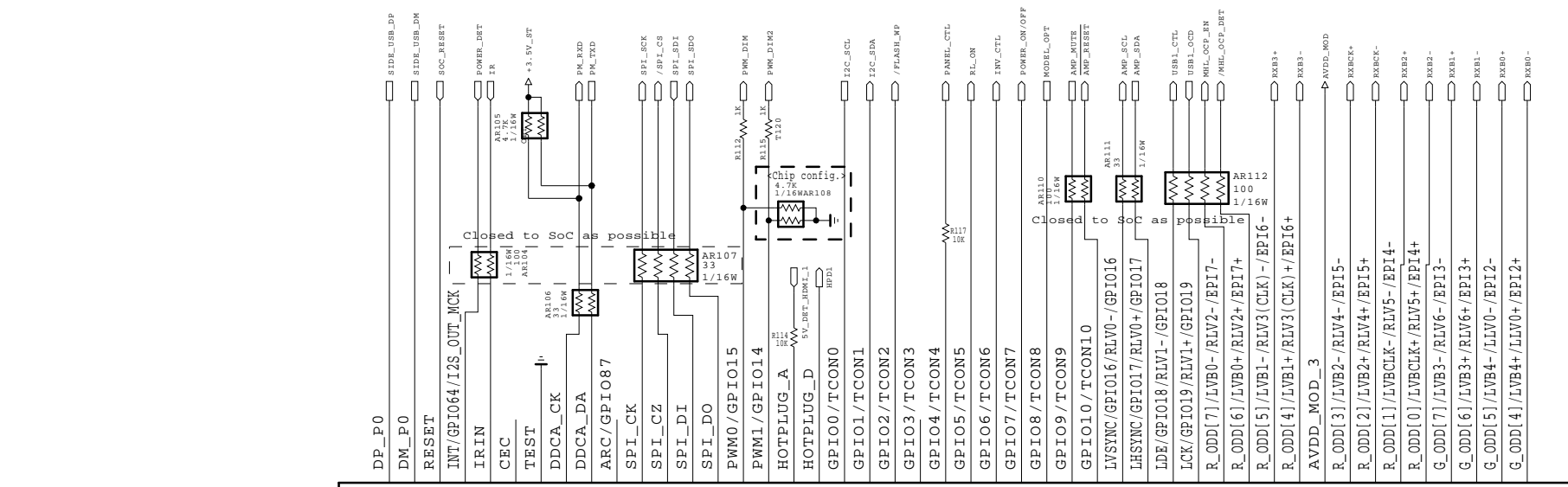
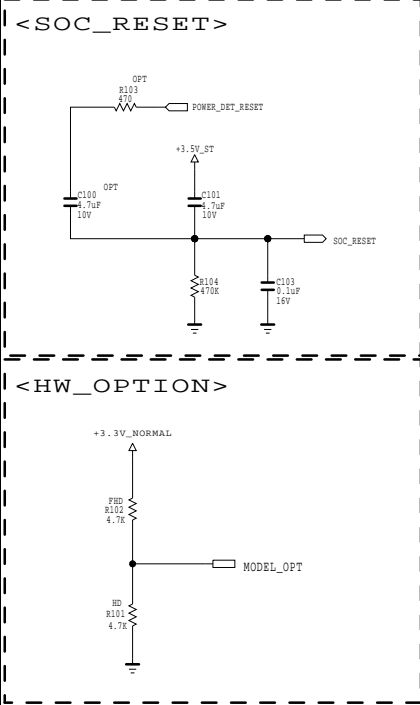

THE SYMBOL MARK OF THIS SCHEMATIC DIAGRAM INCORPORATES SPECIAL FEATURES IMPORTANT FOR PROTECTION FROM X-RADIATION. FIRE AND ELECTRICAL SHOCK HAZARDS, WHEN SERVICING IF IS ESSENTIAL THAT ONLY MANUFACTURERS SPECIFIED PARTS BE USED FOR THE CRITICAL COMPONENTS IN THE SYMBOL MARK OF THE SCHEMATIC.

SECRET
LGElectronics



MODEL	L14-NON-OS	DATE	2013-08-13
BLOCK	MAIN	SHEET	1 / 8

AUDIO AMP (TI) / LVDS / IR

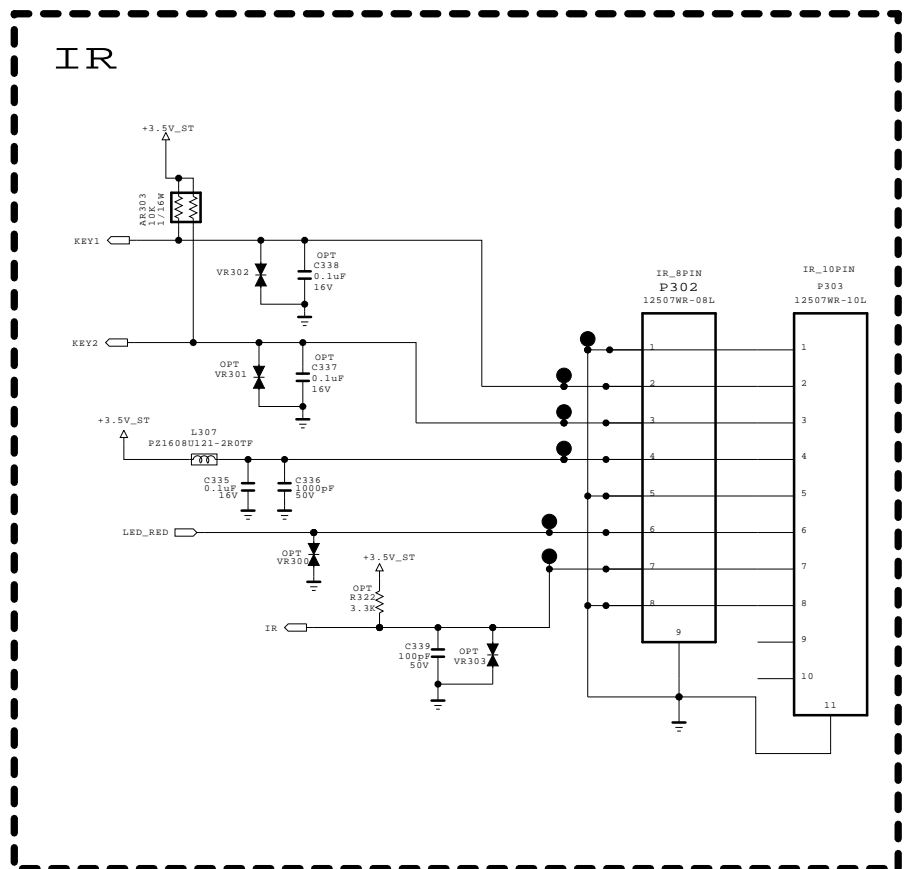
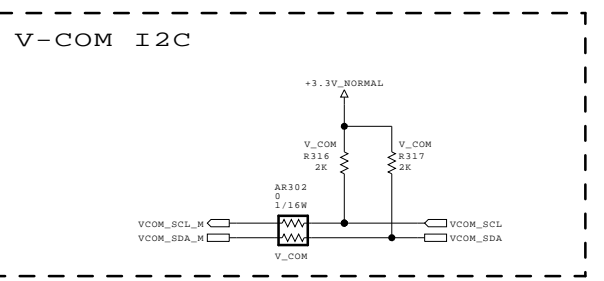
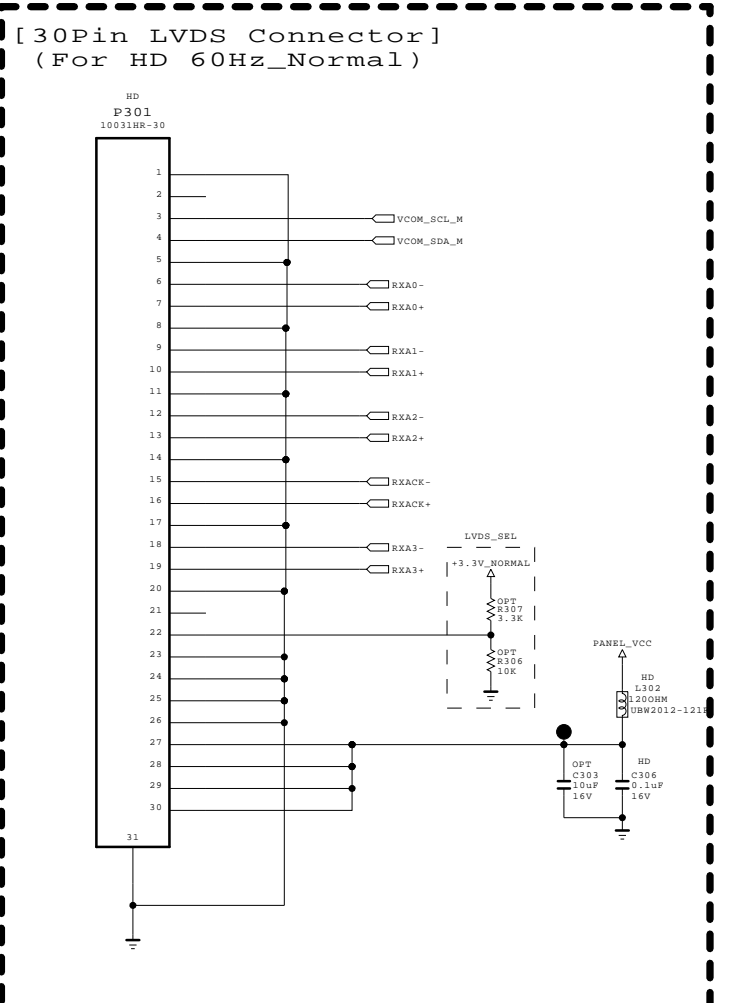
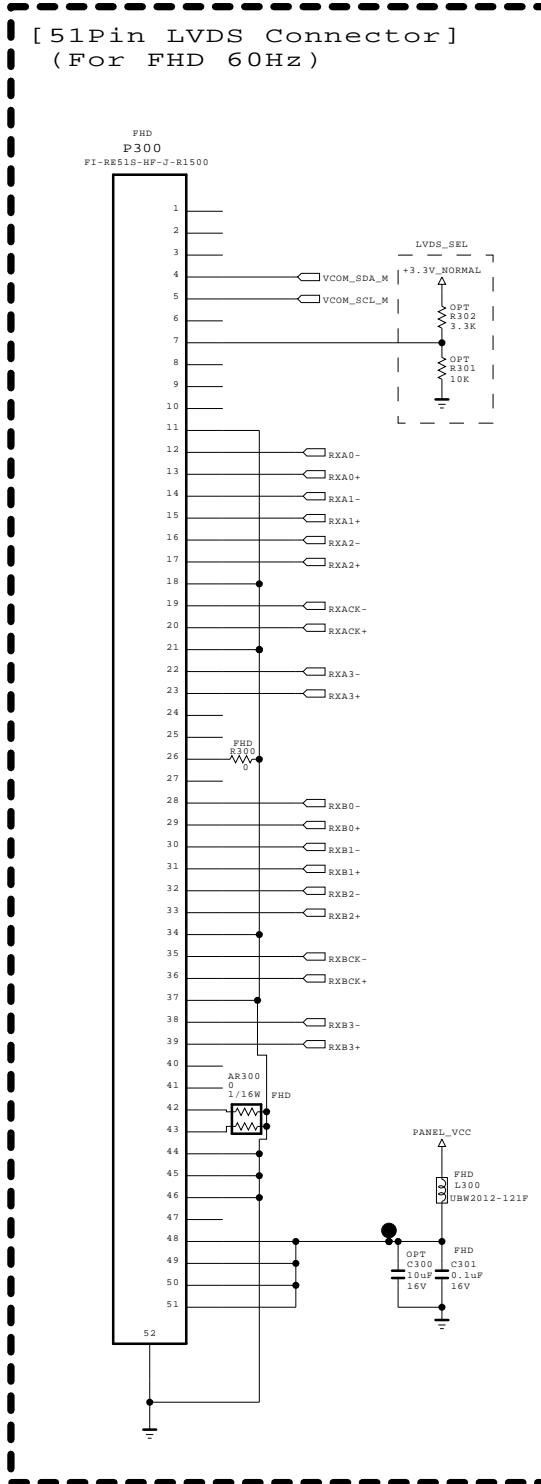

AUDIO AMP (TI)

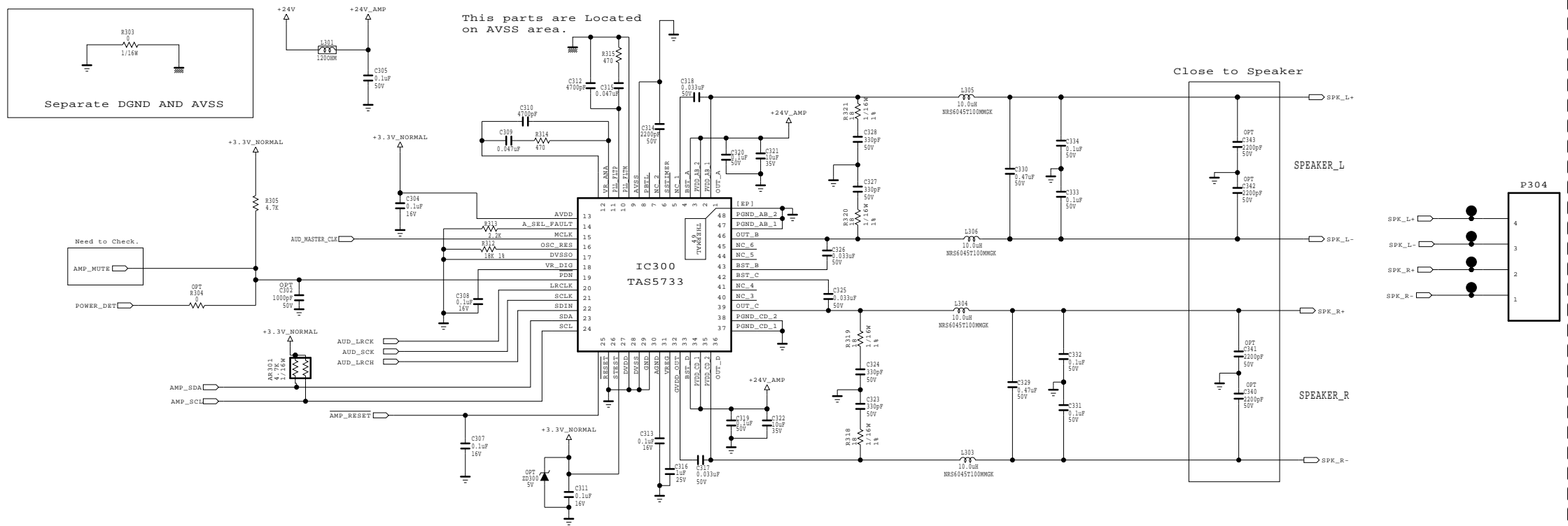

THE SYMBOL MARK OF THIS SCHEMATIC DIAGRAM INCORPORATES SPECIAL FEATURES IMPORTANT FOR PROTECTION FROM X-RADIATION. FIRE AND ELECTRICAL SHOCK HAZARDS, WHEN SERVICING IF IS ESSENTIAL THAT ONLY MANUFACTURERS SPECIFIED PARTS BE USED FOR THE CRITICAL COMPONENTS IN THE SYMBOL MARK OF THE SCHEMATIC.

SECRET
LGElectronics



MODEL	L14-NON-OS	DATE	13/08/13
BLOCK	LVDS/S_AMP/IR	SHEET	3 of 6

EXTERNAL INTERFACE

AV / COMPONENT

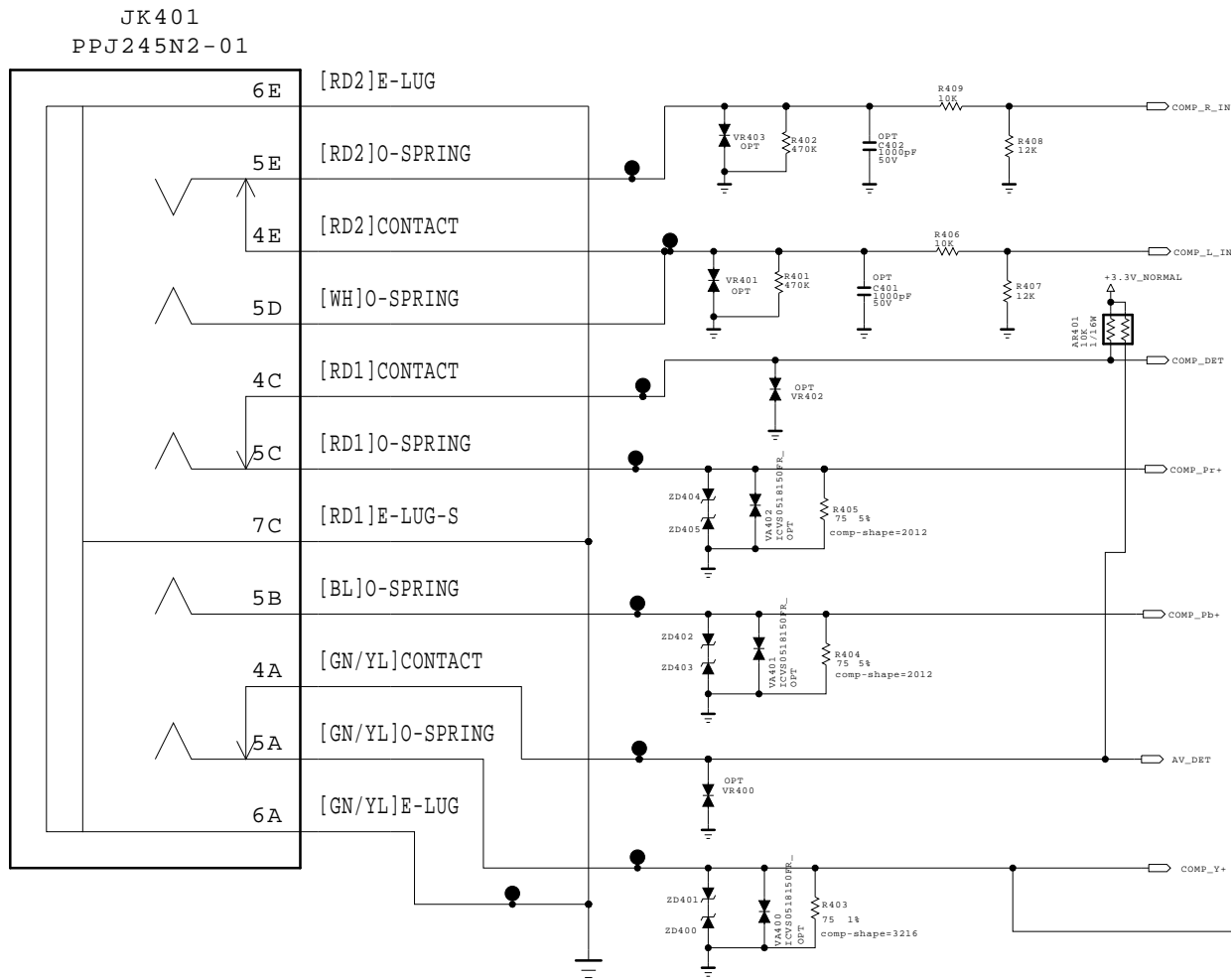

CVBS_OUT

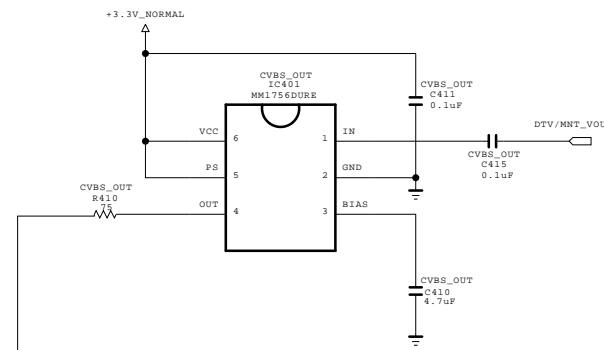

HDMI_1 (REAR)

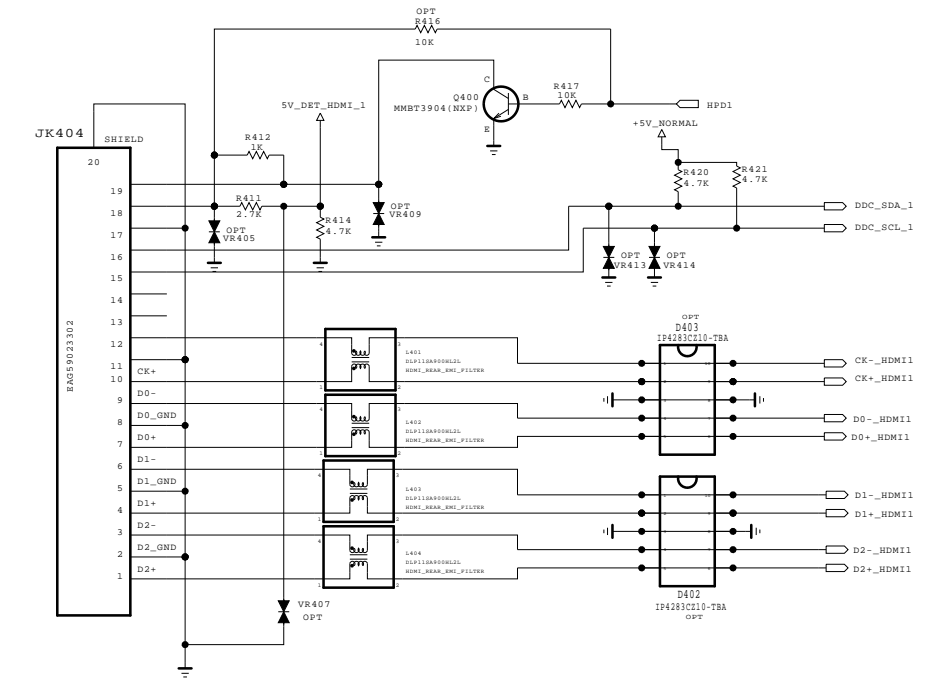

HDMI_2 (SIDE)

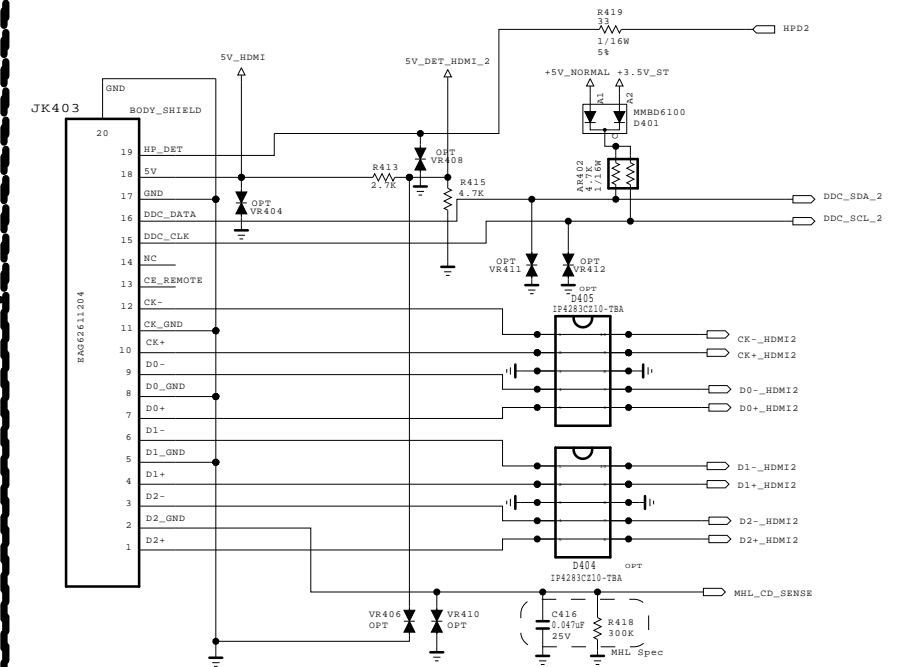

UART For DEBUG

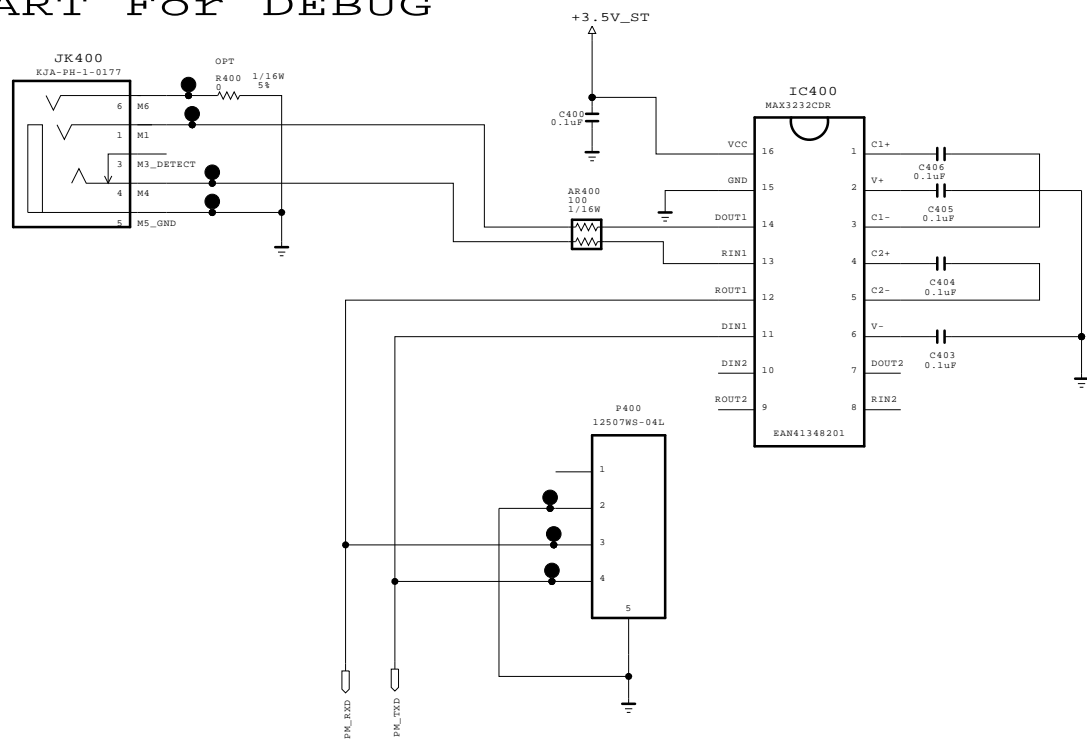

USB (SIDE)

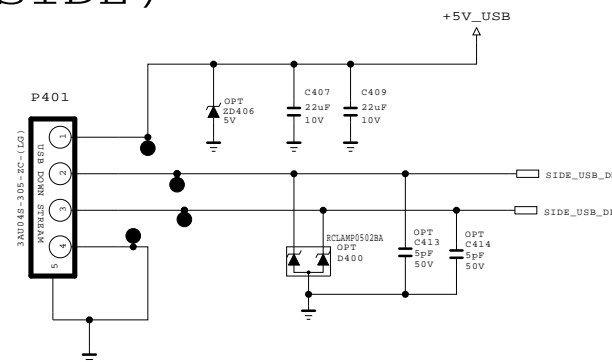

SPDIF OPTIC JACK

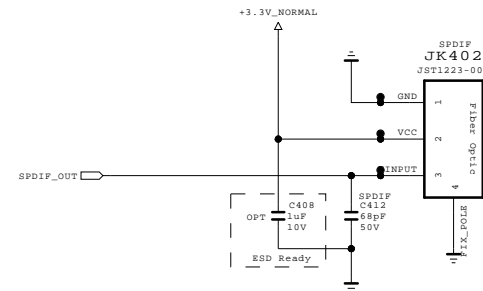

THE SYMBOL MARK OF THIS SCHEMATIC DIAGRAM INCORPORATES SPECIAL FEATURES IMPORTANT FOR PROTECTION FROM X-RADIATION. FIRE AND ELECTRICAL SHOCK HAZARDS, WHEN SERVICING IT IS ESSENTIAL THAT ONLY MANUFACTURERS SPECIFIED PARTS BE USED FOR THE CRITICAL COMPONENTS IN THE SYMBOL MARK OF THE SCHEMATIC.

SECRET
LGElectronics

LG ELECTRONICS

MODEL	L14-NON-OS	DATE	2013.08.13
BLOCK	COMP/USB/SPDIF	SHEET	6

TUNER for ATSC W/O Isolator

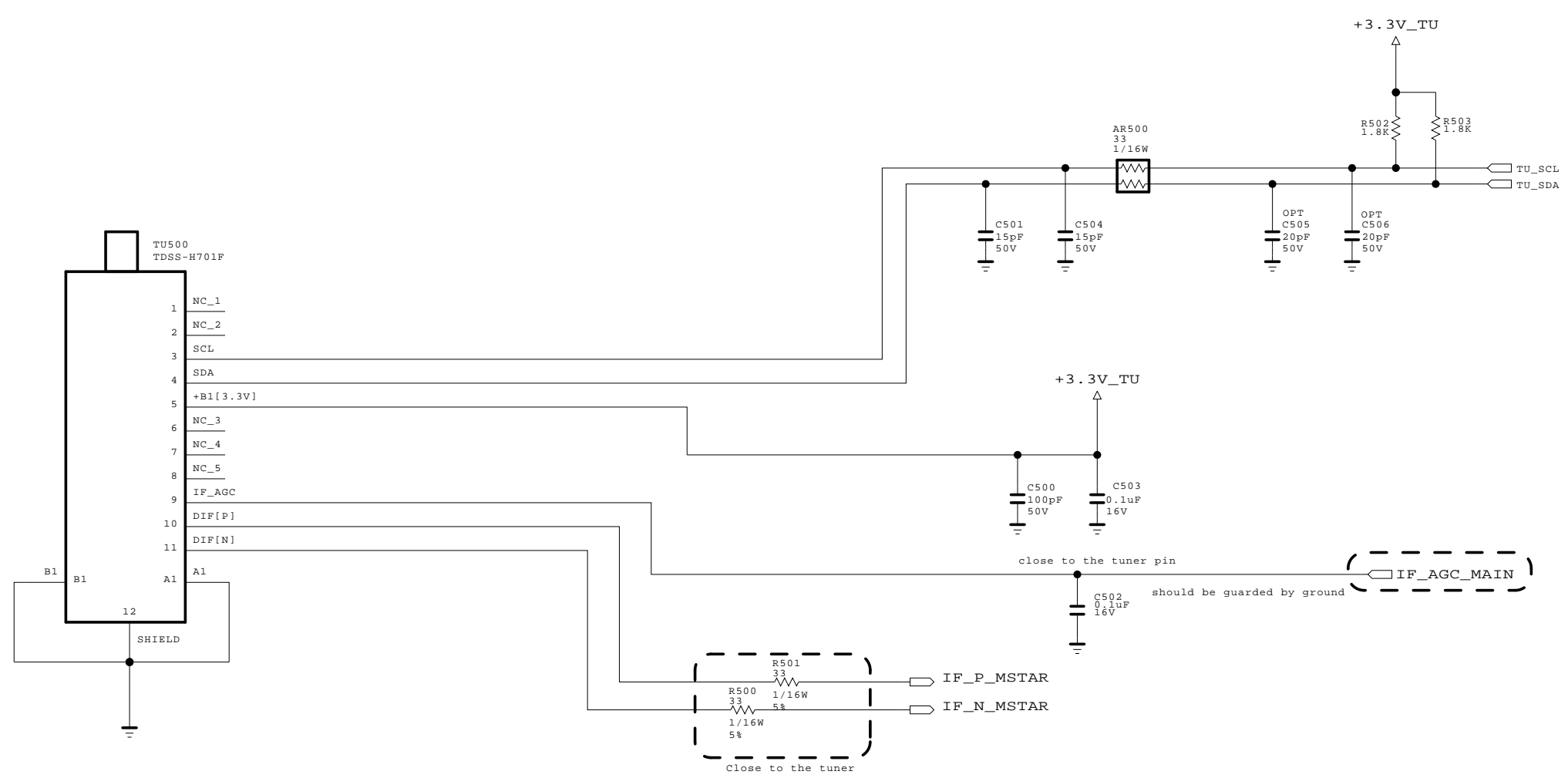
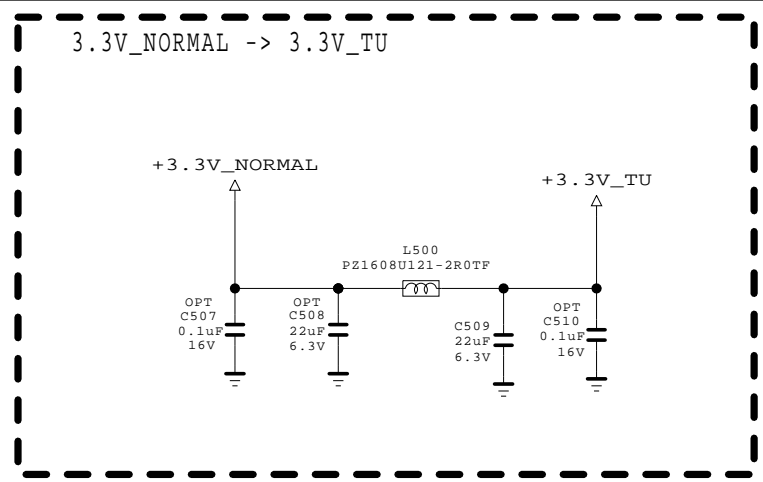

1. should be guarded by ground
2. No via on both of them
3. Signal Width >= 12mils
Signal to Signal Width = 12mils
Ground Width >= 24mils

THE SYMBOL MARK OF THIS SCHEMATIC DIAGRAM INCORPORATES SPECIAL FEATURES IMPORTANT FOR PROTECTION FROM X-RADIATION. FIRE AND ELECTRICAL SHOCK HAZARDS, WHEN SERVICING IF IS ESSENTIAL THAT ONLY MANUFACTURERS SPECIFIED PARTS BE USED FOR THE CRITICAL COMPONENTS IN THE SYMBOL MARK OF THE SCHEMATIC.

SECRET
LGElectronics



MODEL	L14-NON-OS	DATE	2013.08.13
BLOCK	TUNER	SHEET	5 /

