



LG

Life's Good

Internal Use Only

LED TV

SERVICE MANUAL

CHASSIS : UA62F

MODEL : 75UH8500 75UH8500-UD

CAUTION

BEFORE SERVICING THE CHASSIS,
READ THE SAFETY PRECAUTIONS IN THIS MANUAL.

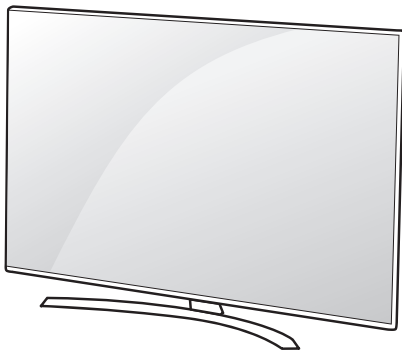

P/NO : MFL69460608 (1604-REV00)

CONTENTS

CONTENTS	2
SAFETY PRECAUTIONS	3
SERVICING PRECAUTIONS	4
SPECIFICATION	6
ADJUSTMENT INSTRUCTION	13
BLOCK DIAGRAM.....	24
EXPLODED VIEW	33
DISASSEMBLY	34
SCHEMATIC CIRCUIT DIAGRAM	APPENDIX
TROUBLE SHOOTING GUIDE	APPENDIX

SAFETY PRECAUTIONS

IMPORTANT SAFETY NOTICE

Many electrical and mechanical parts in this chassis have special safety-related characteristics. These parts are identified by \triangle in the Schematic Diagram and Exploded View.

It is essential that these special safety parts should be replaced with the same components as recommended in this manual to prevent Shock, Fire, or other Hazards.

Do not modify the original design without permission of manufacturer.

General Guidance

An **isolation Transformer should always be used** during the servicing of a receiver whose chassis is not isolated from the AC power line. Use a transformer of adequate power rating as this protects the technician from accidents resulting in personal injury from electrical shocks.

It will also protect the receiver and its components from being damaged by accidental shorts of the circuitry that may be inadvertently introduced during the service operation.

If any fuse (or Fusible Resistor) in this TV receiver is blown, replace it with the specified.

When replacing a high wattage resistor (Oxide Metal Film Resistor, over 1 W), keep the resistor 10 mm away from PCB.

Keep wires away from high voltage or high temperature parts.

Before returning the receiver to the customer,

always perform an **AC leakage current check** on the exposed metallic parts of the cabinet, such as antennas, terminals, etc., to be sure the set is safe to operate without damage of electrical shock.

Leakage Current Cold Check(Antenna Cold Check)

With the instrument AC plug removed from AC source, connect an electrical jumper across the two AC plug prongs. Place the AC switch in the on position, connect one lead of ohm-meter to the AC plug prongs tied together and touch other ohm-meter lead in turn to each exposed metallic parts such as antenna terminals, phone jacks, etc.

If the exposed metallic part has a return path to the chassis, the measured resistance should be between 1 M Ω and 5.2 M Ω .

When the exposed metal has no return path to the chassis the reading must be infinite.

An other abnormality exists that must be corrected before the receiver is returned to the customer.

Leakage Current Hot Check (See below Figure)

Plug the AC cord directly into the AC outlet.

Do not use a line Isolation Transformer during this check.

Connect 1.5 K / 10 watt resistor in parallel with a 0.15 uF capacitor between a known good earth ground (Water Pipe, Conduit, etc.) and the exposed metallic parts.

Measure the AC voltage across the resistor using AC voltmeter with 1000 ohms/volt or more sensitivity.

Reverse plug the AC cord into the AC outlet and repeat AC voltage measurements for each exposed metallic part. Any voltage measured must not exceed 0.75 volt RMS which corresponds to 0.5 mA.

In case any measurement is out of the limits specified, there is possibility of shock hazard and the set must be checked and repaired before it is returned to the customer.

Leakage Current Hot Check circuit

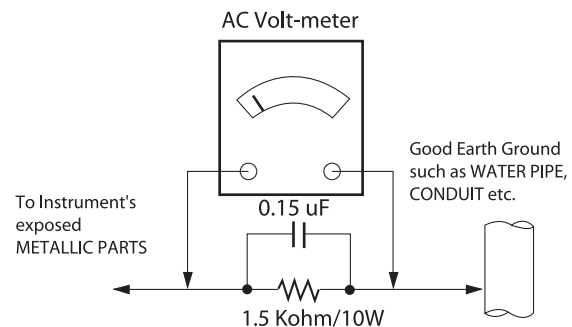

When 25A is impressed between Earth and 2nd Ground for 1 second, Resistance must be less than 0.1 Ω

*Base on Adjustment standard

SERVICING PRECAUTIONS

CAUTION: Before servicing receivers covered by this service manual and its supplements and addenda, read and follow the **SAFETY PRECAUTIONS** on page 3 of this publication.
NOTE: If unforeseen circumstances create conflict between the following servicing precautions and any of the safety precautions on page 3 of this publication, always follow the safety precautions. Remember: Safety First.

General Servicing Precautions

1. Always unplug the receiver AC power cord from the AC power source before;
 - a. Removing or reinstalling any component, circuit board module or any other receiver assembly.
 - b. Disconnecting or reconnecting any receiver electrical plug or other electrical connection.
 - c. Connecting a test substitute in parallel with an electrolytic capacitor in the receiver.
CAUTION: A wrong part substitution or incorrect polarity installation of electrolytic capacitors may result in an explosion hazard.
2. Test high voltage only by measuring it with an appropriate high voltage meter or other voltage measuring device (DVM, FETVOM, etc) equipped with a suitable high voltage probe. Do not test high voltage by "drawing an arc".
3. Do not spray chemicals on or near this receiver or any of its assemblies.
4. Unless specified otherwise in this service manual, clean electrical contacts only by applying the following mixture to the contacts with a pipe cleaner, cotton-tipped stick or comparable non-abrasive applicator; 10 % (by volume) Acetone and 90 % (by volume) isopropyl alcohol (90 % - 99 % strength)
CAUTION: This is a flammable mixture.
Unless specified otherwise in this service manual, lubrication of contacts is not required.
5. Do not defeat any plug/socket B+ voltage interlocks with which receivers covered by this service manual might be equipped.
6. Do not apply AC power to this instrument and/or any of its electrical assemblies unless all solid-state device heat sinks are correctly installed.
7. Always connect the test receiver ground lead to the receiver chassis ground before connecting the test receiver positive lead.
Always remove the test receiver ground lead last.
8. Use with this receiver only the test fixtures specified in this service manual.
CAUTION: Do not connect the test fixture ground strap to any heat sink in this receiver.

Electrostatically Sensitive (ES) Devices

Some semiconductor (solid-state) devices can be damaged easily by static electricity. Such components commonly are called Electrostatically Sensitive (ES) Devices. Examples of typical ES devices are integrated circuits and some field-effect transistors and semiconductor "chip" components. The following techniques should be used to help reduce the incidence of component damage caused by static by static electricity.

1. Immediately before handling any semiconductor component or semiconductor-equipped assembly, drain off any electrostatic charge on your body by touching a known earth ground. Alternatively, obtain and wear a commercially available discharging wrist strap device, which should be removed to prevent potential shock reasons prior to applying power to the unit under test.

2. After removing an electrical assembly equipped with ES devices, place the assembly on a conductive surface such as aluminum foil, to prevent electrostatic charge buildup or exposure of the assembly.
3. Use only a grounded-tip soldering iron to solder or unsolder ES devices.
4. Use only an anti-static type solder removal device. Some solder removal devices not classified as "anti-static" can generate electrical charges sufficient to damage ES devices.
5. Do not use freon-propelled chemicals. These can generate electrical charges sufficient to damage ES devices.
6. Do not remove a replacement ES device from its protective package until immediately before you are ready to install it. (Most replacement ES devices are packaged with leads electrically shorted together by conductive foam, aluminum foil or comparable conductive material).
7. Immediately before removing the protective material from the leads of a replacement ES device, touch the protective material to the chassis or circuit assembly into which the device will be installed.
CAUTION: Be sure no power is applied to the chassis or circuit, and observe all other safety precautions.
8. Minimize bodily motions when handling unpackaged replacement ES devices. (Otherwise harmless motion such as the brushing together of your clothes fabric or the lifting of your foot from a carpeted floor can generate static electricity sufficient to damage an ES device.)

General Soldering Guidelines

1. Use a grounded-tip, low-wattage soldering iron and appropriate tip size and shape that will maintain tip temperature within the range or 500 °F to 600 °F.
2. Use an appropriate gauge of RMA resin-core solder composed of 60 parts tin/40 parts lead.
3. Keep the soldering iron tip clean and well tinned.
4. Thoroughly clean the surfaces to be soldered. Use a small wire-bristle (0.5 inch, or 1.25 cm) brush with a metal handle. Do not use freon-propelled spray-on cleaners.
5. Use the following unsoldering technique
 - a. Allow the soldering iron tip to reach normal temperature. (500 °F to 600 °F)
 - b. Heat the component lead until the solder melts.
 - c. Quickly draw the melted solder with an anti-static, suction-type solder removal device or with solder braid.
CAUTION: Work quickly to avoid overheating the circuit board printed foil.
6. Use the following soldering technique.
 - a. Allow the soldering iron tip to reach a normal temperature (500 °F to 600 °F)
 - b. First, hold the soldering iron tip and solder the strand against the component lead until the solder melts.
 - c. Quickly move the soldering iron tip to the junction of the component lead and the printed circuit foil, and hold it there only until the solder flows onto and around both the component lead and the foil.
CAUTION: Work quickly to avoid overheating the circuit board printed foil.
 - d. Closely inspect the solder area and remove any excess or splashed solder with a small wire-bristle brush.

IC Remove/Replacement

Some chassis circuit boards have slotted holes (oblong) through which the IC leads are inserted and then bent flat against the circuit foil. When holes are the slotted type, the following technique should be used to remove and replace the IC. When working with boards using the familiar round hole, use the standard technique as outlined in paragraphs 5 and 6 above.

Removal

1. Desolder and straighten each IC lead in one operation by gently prying up on the lead with the soldering iron tip as the solder melts.
2. Draw away the melted solder with an anti-static suction-type solder removal device (or with solder braid) before removing the IC.

Replacement

1. Carefully insert the replacement IC in the circuit board.
2. Carefully bend each IC lead against the circuit foil pad and solder it.
3. Clean the soldered areas with a small wire-bristle brush. (It is not necessary to reapply acrylic coating to the areas).

"Small-Signal" Discrete Transistor Removal/Replacement

1. Remove the defective transistor by clipping its leads as close as possible to the component body.
2. Bend into a "U" shape the end of each of three leads remaining on the circuit board.
3. Bend into a "U" shape the replacement transistor leads.
4. Connect the replacement transistor leads to the corresponding leads extending from the circuit board and crimp the "U" with long nose pliers to insure metal to metal contact then solder each connection.

Power Output, Transistor Device

Removal/Replacement

1. Heat and remove all solder from around the transistor leads.
2. Remove the heat sink mounting screw (if so equipped).
3. Carefully remove the transistor from the heat sink of the circuit board.
4. Insert new transistor in the circuit board.
5. Solder each transistor lead, and clip off excess lead.
6. Replace heat sink.

Diode Removal/Replacement

1. Remove defective diode by clipping its leads as close as possible to diode body.
2. Bend the two remaining leads perpendicular y to the circuit board.
3. Observing diode polarity, wrap each lead of the new diode around the corresponding lead on the circuit board.
4. Securely crimp each connection and solder it.
5. Inspect (on the circuit board copper side) the solder joints of the two "original" leads. If they are not shiny, reheat them and if necessary, apply additional solder.

Fuse and Conventional Resistor

Removal/Replacement

1. Clip each fuse or resistor lead at top of the circuit board hollow stake.
2. Securely crimp the leads of replacement component around notch at stake top.

3. Solder the connections.

CAUTION: Maintain original spacing between the replaced component and adjacent components and the circuit board to prevent excessive component temperatures.

Circuit Board Foil Repair

Excessive heat applied to the copper foil of any printed circuit board will weaken the adhesive that bonds the foil to the circuit board causing the foil to separate from or "lift-off" the board. The following guidelines and procedures should be followed whenever this condition is encountered.

At IC Connections

To repair a defective copper pattern at IC connections use the following procedure to install a jumper wire on the copper pattern side of the circuit board. (Use this technique only on IC connections).

1. Carefully remove the damaged copper pattern with a sharp knife. (Remove only as much copper as absolutely necessary).
2. Carefully scratch away the solder resist and acrylic coating (if used) from the end of the remaining copper pattern.
3. Bend a small "U" in one end of a small gauge jumper wire and carefully crimp it around the IC pin. Solder the IC connection.
4. Route the jumper wire along the path of the out-away copper pattern and let it overlap the previously scraped end of the good copper pattern. Solder the overlapped area and clip off any excess jumper wire.

At Other Connections

Use the following technique to repair the defective copper pattern at connections other than IC Pins. This technique involves the installation of a jumper wire on the component side of the circuit board.

1. Remove the defective copper pattern with a sharp knife. Remove at least 1/4 inch of copper, to ensure that a hazardous condition will not exist if the jumper wire opens.
2. Trace along the copper pattern from both sides of the pattern break and locate the nearest component that is directly connected to the affected copper pattern.
3. Connect insulated 20-gauge jumper wire from the lead of the nearest component on one side of the pattern break to the lead of the nearest component on the other side. Carefully crimp and solder the connections.
CAUTION: Be sure the insulated jumper wire is dressed so the it does not touch components or sharp edges.

SPECIFICATION

NOTE : Specifications and others are subject to change without notice for improvement.

1. Application range

This spec sheet is applied to the LED TV used UA62F chassis

3. Test method

- (1) Performance: LGE TV test method followed
- (2) Demanded other specification
 - Safety : CE, IEC specification
 - EMC : CE, IEC

2. Test condition

Each part is tested as below without special notice.

- (1) Temperature : 25 °C ± 5 °C(77±9°F), CST : 40 °C±5 °C
- (2) Relative Humidity: 65 % ± 10 %
- (3) Power Voltage
 - Standard input voltage (100~240V@ 50/60Hz)
 - * Standard Voltage of each products is marked by models.
- (4) Specification and performance of each parts are followed each drawing and specification by part number in accordance with BOM.
- (5) The receiver must be operated for about 20 minutes prior to the adjustment.

4. General Specification

4.1. Model Specification

No	Item	Specification	Remark	
1	Market	North America		
2	Broadcasting system	Digital : DVB-T2, ATSC /64 & 256 QAM, ATSC Analog : NTSC-M / NTSC-M		
3	Available Channel	VHF : 2~13		
		UHF : 14~69		
		DTV : 2-69		
		CATV : 1 ~ 135		
		CADTV : 1 ~ 135		
		DTV(UHD) : 2 ~ 69		
4	Receiving system	Digital : ATSC Analog : NTSC-M		
5	Video Input	NTSC-M	Rear gender(1EA)	
6	Component Input	Y/Cb/Cr, Y/ Pb/Pr	Rear gender(1EA)	
7	HDMI Input	HDMI 1	PC / DTV format	Support 6Gbps
		HDMI 2	PC / DTV format	Support 6Gbps, Support ARC
		HDMI 3	PC / DTV format	Support 6Gbps
8	Audio Input	Component / AV Audio / DVI Audio	L/R Input ; Rear(Gender) Component and av and DVI use same jack ; Rear (Gender)	
9	SPDIF out(1EA)	Optical Audio out	Rear (1EA),	
10	USB Input(3EA)	EMF, DivX HD, For SVC (download)	JPEG, MP3, DivX HD	

5. External input format

5.1. 2D Mode

5.1.1. Component input(Y, PB, PR)

No	Resolution	H-freq(kHz)	V-freq.(Hz)	Pixel clock(MHz)	Proposed
1	720*480i	15.73	59.94	13.50	SDTV, DVD 480I(525I)
2	720*480i	15.75	60.00	13.51	SDTV, DVD 480I(525I)
3	720*576i	15.62	50.00	13.50	SDTV, DVD 576I(625I) 50Hz
4	720*480p	31.47	59.94	27.00	SDTV 480P
5	720*480p	31.50	60.00	27.02	SDTV 480P
6	720*576p	31.25	50.00	27.00	SDTV 576P 50Hz
7	1280*720	44.96	59.94	74.17	HDTV 720P
8	1280*720	45.00	60.00	74.25	HDTV 720P
9	1280*720	37.50	50.00	74.25	HDTV 720P 50Hz
10	1920*1080	28.12	50.00	74.25	HDTV 1080I 50Hz,
11	1920*1080	33.72	59.94	74.17	HDTV 1080I
12	1920*1080	33.75	60.00	74.25	HDTV 1080I
13	1920*1080	56.25	50	148.5	HDTV 1080P
14	1920*1080	67.43	59.94	148.5	HDTV 1080P
15	1920*1080	67.50	60.00	148.5	HDTV 1080P

5.1.2. HDMI Input (PC/DTV)

No.	Resolution	H-freq(kHz)	V-freq.(kHz)	Pixel clock(MHz)	Proposed	
	HDMI-PC					
1	640*350	31.46	70.09	25.17	EGA	
2	720*400	31.46	70.08	28.32	DOS	
3	640*480	31.46	59.94	25.17	VESA(VGA)	
4	800*600	37.87	60.31	40	VESA(SVGA)	
5	1024*768	48.36	60.00	65	VESA(XGA)	
6	1360*768	47.71	60.01	84.75	VESA(WXGA)	
7	1152*864	54.34	60.05	80	VESA	
8	1280*1024	63.98	60.02	109.00	SXGA	Support to HDMI-PC
9	1920*1080	67.5	60	158.40	WUXGA(Reduced Blanking)	
10	3840*2160	54	24.00	297.00	UDTV 2160P	
11	3840*2160	56.25	25.00	297.00	UDTV 2160P	
12	3840*2160	67.5	30.00	297.00	UDTV 2160P	
13	4096*2160	53.95	23.97	296.70	UDTV 2160P	
14	4096*2160	54	24	297	UDTV 2160P	

HDMI-DTV						
No.	Resolution	H-freq(kHz)	V-freq.(kHz)	Pixel clock(MHz)	Proposed	Remarks
1	640*480	31.46	59.94	25.12	SDTV 480P	
2	640*480	31.5	60.00	25.12	SDTV 480P	
3	720*480	15.73	59.94	13.50	SDTV, DVD 480I(525I)	Spec. out but display
4	720*480	15.75	60.00	13.51	SDTV, DVD 480I(525I)	
5	720*576	15.62	50.00	13.50	SDTV, DVD 576I(625I) 50Hz	
6	720*480	31.47	59.94	27	SDTV 480P	
7	720*480	31.5	60.00	27.02	SDTV 480P	
8	720*576	31.25	50.00	27	SDTV 576P	
9	1280*720	44.96	59.94	74.17	HDTV 720P	
10	1280*720	45	60.00	74.25	HDTV 720P	
11	1280*720	37.5	50.00	74.25	HDTV 720P	
12	1920*1080	28.12	50.00	74.25	HDTV 1080I	
13	1920*1080	33.72	59.94	74.17	HDTV 1080I	
14	1920*1080	33.75	60.00	74.25	HDTV 1080I	
15	1920*1080	26.97	23.97	63.29	HDTV 1080P	
16	1920*1080	27.00	24.00	63.36	HDTV 1080P	
17	1920*1080	33.71	29.97	79.120	HDTV 1080P	
18	1920*1080	33.75	30.00	79.20	HDTV 1080P	
19	1920*1080	56.25	50.00	148.5	HDTV 1080P	
20	1920*1080	67.43	59.94	148.35	HDTV 1080P	
21	1920*1080	67.5	60.00	148.50	HDTV 1080P	
22	3840*2160	53.95	23.98	296.70	UDTV 2160P	
23	3840*2160	54	24.00	297.00	UDTV 2160P	
24	3840*2160	56.25	25.00	297.00	UDTV 2160P	
25	3840*2160	61.43	29.97	296.70	UDTV 2160P	
26	3840*2160	67.5	30.00	297.00	UDTV 2160P	
27	3840*2160	112.5	50.00	594	UDTV 2160P	When HDMI1,2,3 UHD DEEP COLOUR ON
28	3840*2160	134.86	59.94	593.40	UDTV 2160P	
29	3840*2160	135	60.00	594	UDTV 2160P	
30	4096*2160	53.95	23.98	296.70	UDTV 2160P	
31	4096*2160	54	24.00	297	UDTV 2160P	
32	4096*2160	56.25	25.00	297	UDTV 2160P	
33	4096*2160	61.43	29.97	296.70	UDTV 2160P	
34	4096*2160	67.5	30.00	297	UDTV 2160P	
35	4096*2160	112.5	50.00	594	UDTV 2160P	When HDMI1,2,3 UHD DEEP COLOUR ON
36	4096*2160	134.86	59.94	593.40	UDTV 2160P	
37	4096*2160	135	60.00	594	UDTV 2160P	

5.2. 3D Mode

5.2.1. HDMI Input 1.4b (3D supported mode automatically)

No	Resolution	H-freq(kHz)	V-freq.(Hz)	Pixel clock (MHz)	VIC	3D input proposed mode	Proposed
1	640*480	31.46 / 31.5	59.94/ 60	25.17/25.2	1	Top-and-Bottom Side-by-side(half)	Secondary(SDTV 480P) Secondary(SDTV 480P)
		62.93 / 63	59.94/ 60	50.35/50.4	1	Frame packing Line alternative	Secondary(SDTV 480P) (SDTV 480P)
		31.46 / 31.5	59.94/ 60	50.35/50.4	1	Side-by-side(Full)	(SDTV 480P)
2	720*480	31.46 / 31.5	59.94 / 60	27.00/27.03	2,3	Top-and-Bottom Side-by-side(half)	Secondary(SDTV 480P) Secondary(SDTV 480P)
		62.93 / 63	59.94 / 60	54/54.06	2,3	Frame packing Line alternative	Secondary(SDTV 480P) (SDTV 480P)
3	720*576	31.25	50	27	17,18	Top-and-Bottom Side-by-side(half)	Secondary(SDTV 576P) Secondary(SDTV 576P)
		62.5	50	54	17,18	Frame packing	Secondary(SDTV 576P)
4	720*576	15.62	50	27	21	Frame packing Top-and-Bottom Side-by-side(half)	Secondary(SDTV 576I) Secondary(SDTV 576I) Secondary(SDTV 576I)
5	1280*720	37.50	50	74.25	19	Top-and-Bottom Side-by-side(half)	Primary(HDTV 720P) Primary(HDTV 720P)
		44.96 / 45	59.94 / 60	74.17/74.25	4	Top-and-Bottom Side-by-side(half)	Primary(HDTV 720P) Primary(HDTV 720P)
		75	50	148.5	19	Frame packing	Primary(HDTV 720P)
		89.91/90	59.94 / 60	148.35/148.5	4	Frame packing	Primary(HDTV 720P)
6	1920*1080	28.12	50.00	74.25	20	Top-and-Bottom Side-by-side(half)	Secondary(HDTV 1080I) Primary(HDTV 1080I)
		33.72 / 33.75	59.94 / 60	74.17/74.25	5	Top-and-Bottom Side-by-side(half)	Secondary(HDTV 1080I) Primary(HDTV 1080I)
		56.25	50.00	148.5	20	Frame packing	Primary(HDTV 1080I)
		67.43/67.50	59.94 / 60	148.35/148.5	5	Frame packing	Primary(HDTV 1080I)
7	1920*1080	26.97 / 27	23.97 / 24	74.17/74.25	32	Top-and-Bottom Side-by-side(half)	Primary(HDTV 1080P) Primary(HDTV 1080P)
		28.12	25	74.25	33	Top-and-Bottom Side-by-side(half)	Secondary(HDTV 1080P) Secondary(HDTV 1080P)
		33.71 / 33.75	29.97 / 30.00	74.18/74.25	34	Top-and-Bottom Side-by-side(half)	Primary(HDTV 1080P) Secondary(HDTV 1080P)
		43.94/54	23.97 / 24	148.35/148.5	32	Frame packing	Primary(HDTV 1080P)
		56.25	25	148.5	33	Frame packing	Secondary(HDTV 1080P)
		67.43 / 67.5	29.97 / 30.00	148.35/148.5	34	Frame packing	Primary(HDTV 1080P)
		56.250	50	148.5	31	Top-and-Bottom Side-by-side(half)	Primary(HDTV 1080P) Secondary(HDTV 1080P)
		67.43 / 67.5	59.94 / 60	148.35/148.50	16	Top-and-Bottom Side-by-side(half)	Primary(HDTV 1080P) Secondary(HDTV 1080P)

5.2.2. HDMI 1.4/2.0(3D Supported mode manually)

No	Resolution	H-freq(kHz)	V-freq.(Hz)	Pixel clock (MHz)	Proposed	3D input proposed mode
1	720*480	31.5	60	27.03	SDTV 480P	2D to 3D, Side by Side(Half), Top & Bottom
2	720*576	31.25	50	27	HDTV 720P	
3	1280*720	45.00	60.00	74.25	HDTV 1080I	
		37.50	50	74.25	HDTV 1080P	
4	1920*1080	33.75	60.00	74.25	HDTV 1080P	
		28.125	50.00	74.25	HDTV 1080P	
5	1920*1080	27.00	24.00	74.25	HDTV 1080P	
		28.12	25	74.25	HDTV 2160P	
		33.75	30.00	74.25	HDTV 2160P	
		67.50	60.00	148.5	HDTV 2160P	
		56.250	50	148.5	HDTV 2160P	
6	3840*2160 4096*2160	53.95	23.97	296.70	HDTV 2160P	2D to 3D, Top & Bottom, Side by Side(half)
		54	24.00	297.00	HDTV 2160P	
		56.25	25.00	297.00	HDTV 2160P	
		61.43	29.97	296.70	HDTV 2160P	
		67.5	30.00	297.00	HDTV 2160P	
7	3840*2160	54	24.00	297.00	HDTV 2160P	2D to 3D, Top & Bottom(half), Side by Side(half), When HDMI1,2,3 UHD DEEP COLOUR ON
8	4096*2160	56.25	25.00	297.00	HDTV 2160P	

5.2.3. HDMI-PC Input (3D) (3D Supported Mode Manually)

No	Resolution	H-freq(kHz)	V-freq.(Hz)	Pixel clock (MHz)	Proposed	3D input proposed mode
1	1024*768	48.36	60	65	HDTV 768P	2D to 3D, Side by Side(half), Top & Bottom
2	1360*768	47.71	60	85.5	HDTV 768P	2D to 3D, Side by Side(half), Top & Bottom
3	1920*1080	67.50	60	148.50	HDTV 1080P	2D to 3D, Side by Side(half), Top & Bottom
4	3840*2160	54	24.00	297.00	HDTV 2160P	2D to 3D, Top & Bottom(half), Side by Side(half),
		56.25	25.00	297.00		
		67.5	30.00	297.00		
5	4096*2160	54	24	297.00	HDTV 2160P	2D to 3D, Top & Bottom(half), Side by Side(half),
6	Others	-	-	-	640*350 720*400 640*480 800*600 1152*864	2D to 3D, Side by Side(half), Top & Bottom

5.2.4. RF Input(3D supported mode manually)

No.	Resolution	H-freq(kHz)	V-freq.(Hz)	Pixel clock(MHz)	Proposed	3D input proposed mode
1	1280*720	37.50	50	74.25	HDTV 720P	2D to 3D, Side by Side, Top & Bottom
2	1920*1080	28.12	50	74.25	HDTV 1080I	2D to 3D, Side by Side, Top & Bottom

5.2.5. RF Input (3D supported mode automatically)

No.	Signal	3D input proposed mode
1	Frame Compatible	Side by Side(Half), Top & Bottom

5.2.6. USB – Movie (3D) (3D supported mode manually)

No.	Resolution	H-freq(kHz)	V-freq.(Hz)	Pixel clock(MHz)	3D input proposed mode
1	Under 704x480	-	-	-	2D to 3D
2	Over 704x480 Under 1080P interlaced	-	-	-	2D to 3D, Side by Side(Half), Top & Bottom
3	Over 704x480 Under 1080P progressive	-	50	-	2D to 3D, Side by Side(Half), Top & Bottom
		-	others	-	2D to 3D, Side by Side(Half), Top & Bottom
4	Over 2160P	-	24/25/30/60	-	2D to 3D, Side by Side(Half), Top & Bottom

5.2.7. USB -Photo (3D) (3D supported mode manually)

No	Resolution	H-freq(kHz)	V-freq.(Hz)	Pixel clock(MHz)	3D input proposed mode
1	Under 320x240	-	-	-	2D to 3D, Side by Side(Half), Top & Bottom
2	Over 320x240	-	-	-	2D to 3D, Side by Side(Half), Top & Bottom

5.2.8. USB(3D) (3D supported mode automatically)

No	Resolution	H-freq(kHz)	V-freq.(Hz)	Pixel clock(MHz)	3D input proposed mode
1	1080p	33.75	30	74.25	Side by Side(Half), Top & Bottom, Side by Side(Full), Frame Sequential, MPO(Photo), JPS(Photo)
2	2160p	67.5	30	297	









5.2.9. Component Input(3D supported mode manually)

No.	Resolution	H-freq(kHz)	V-freq.(Hz)	Pixel clock(MHz)	Proposed	3D input proposed mode
1	1280*720	37.5	50	74.25	HDTV 720P	2D to 3D, Side by Side(half), Top & Bottom
2	1280*720	45.00	60.00	74.25	HDTV 720P	
3	1280*720	44.96	59.94	74.17	HDTV 720P	
4	1920*1080	33.75	60.00	74.25	HDTV 1080I	
5	1920*1080	33.72	59.94	74.17	HDTV 1080I	
6	1920*1080	28.12	50	74.25	HDTV 1080I	
7	1920*1080	67.500	60	148.50	HDTV 1080P	
8	1920*1080	67.43	59.94	148.35	HDTV 1080P	
9	1920*1080	27.00	24.00	74.25	HDTV 1080P	
10	1920*1080	28.12	25	74.25	HDTV 1080P	
11	1920*1080	56.25	50	74.25	HDTV 1080P	
12	1920*1080	26.97	23.97	74.17	HDTV 1080P	
13	1920*1080	33.75	30.00	74.25	HDTV 1080P	
14	1920*1080	33.71	29.97	74.17	HDTV 1080P	

5.2.10. Miracast, Widi (3D supported mode manually)

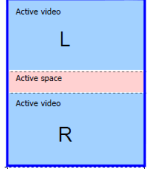
No	Resolution	H-freq(kHz)	V-freq.(Hz)	Pixel clock(MHz)	3D input proposed mode
1	1024X768p	-	30 / 60	-	2D to 3D, Side by Side(Half), Top & Bottom
2	1280x720p	-	30 / 60	-	
3	1920X1080p		30 / 60		
4	Others		-		2D to 3D

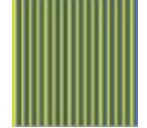
**Remark: 3D Input mode

No.	Side by Side	Top & Bottom	Checker-board	Single Frame Sequential	Frame Packing	Line Interleaving	Column Interleaving	2D to 3D
1								

ADJUSTMENT INSTRUCTION

1. Application Range

This spec. sheet applies to UA62F Chassis applied LED TV all models manufactured in TV factory

2. Specification.

- (1) Because this is not a hot chassis, it is not necessary to use an isolation transformer. However, the use of isolation transformer will help protect test instrument
- (2) Adjustment must be done in the correct order.
- (3) The adjustment must be performed in the circumstance of 25 ±5°C of temperature and 65±10% of relative humidity if there is no specific designation
- (4) The input voltage of the receiver must keep 100~240V, 50/60Hz
- (5) The receiver must be operated for about 5 minutes prior to the adjustment when module is in the circumstance of over 15°C

- In case of keeping module is in the circumstance of 0°C, it should be placed in the circumstance of above 15°C for 2 hours
- In case of keeping module is in the circumstance of below -20°C, it should be placed in the circumstance of above 15°C for 3 hours

* (Caution) When still image is displayed for a period of 20 minutes or longer (especially where W/B scale is strong. Digital pattern 13ch and/or Cross hatch pattern 09ch), there can some afterimage in the black level area.

3. PCB assembly adjustment method

3.1. MAC Address, ESN Key, Wide-vine Key, HDCP 2.2 Download

- D/L Program : keydownload.exe

3.1.1. Equipment & Condition

- (1) Play file: keydownload.exe
- (2) Key Write: Com 1,2,3,4 and 115200 (Baudrate)
- (3) Barcode: Com 1,2,3,4 and 9600 (Baudrate)

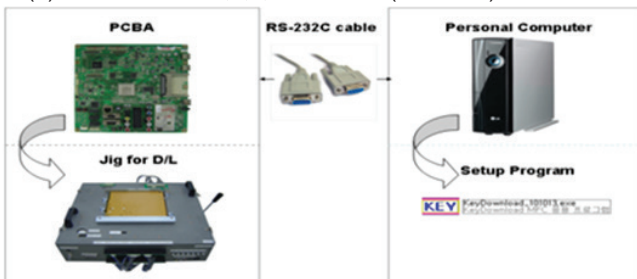

3.1.2. Download Process

(MAC + WIDEVINE + ESN+HDCP2.2)

- (1) Execute "keydownload.exe" on PC
- (2) Select the download items.
- (3) Mode check : Online only
- (4) Check the test process
 - DETECT -> MAC_WRITE -> ESN_WRITE (only Colombia/Panama) -> WIDEVINE_WRITE
- (5) Play: START
- (6) Check of result: Ready, Test, OK or NG

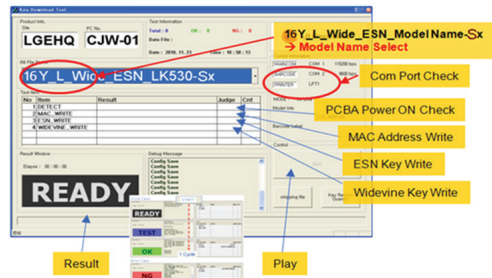

3.1.3. Inspection : ININSTART menu, check these keys.

3.2. LAN Test(Ping-test)

3.2.1. PING Test(LAN Operating Test)

3.2.1.1. Check PCBA

- (1) Connect LAN to PCBA& Power On.(Default IP can be set to automatic setting. When power ON, IP can be Automatically be achieved from the router)
- (2) Push ADJ key on Adjust remote-controller.
- (3) Enter "13. ACAP PING TEST" & check Network.

3.2.1.2. Check Set(Manufacturer)

- (1) Connect TV-Set & PC with Cross LAN cable.(PC IP : 12.12.2.3)
- (2) Execute "PINT Test program", Check setting data of program. (TV-Set IP : 12.12.2.2)



- (3) Push Power Only key on Adjust remote-controller.
- (4) Click "RUN", Check "OK" or "NG"

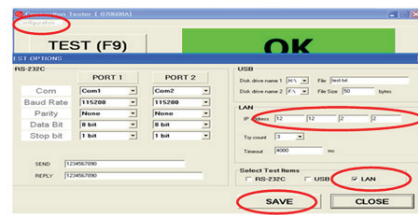

3.3. Main S/W program download

3.3.1. Using the Memory Stick

- ** USB DOWNLOAD : Service Mode
- (1) Insert the USB memory Stick to the USB port
 - (2) Automatically detect the SW Version.
-> S/W download process is executed automatically.
 - (3) Show the message "Copy the file from the Memory"

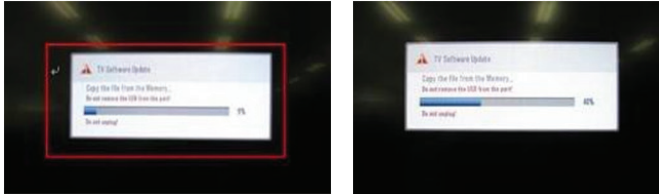

- (4) After Finished the Download, Automatically DC Off -> On

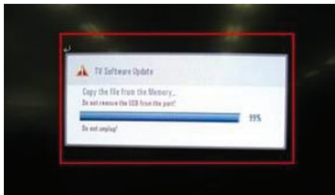

- (5) If the TV IS Turn On, Check the updated SW Version and Tool Option.

3.4. Input tool option

Adjust tool option refer to the BOM.

- Tool Option Input : PCBA Check Process
- Area Option Input : Set Assembly Process

After Input Tool Option and AC off
Before PCBA check, you have to change the Tool option and have to AC off/on (Plug out and in)
(If missing this process, set can operate abnormally)

3.4.1. Profile

Must be changed the option value because being different with some setting value depend on module maker, inch and market

3.4.2. Equipment

adjustment remote control.

3.4.3. Adjustment method

- The input methods are same as other chassis.(Use ADJ Key on the Adjust Remocon.)
(If not changed the option, the input menu can differ the model spec.)
Refer to Job Expression of each main chassis ass'y (EBTxxxxxxx) for Option value

(Caution)
Don't Press "IN-STOP" key after completing the function inspection.

3.5. EDID D/L method

Recommend that don't connect HDMI and RGB(D-SUB) cable when downloading the EDID.

If not possible, recommend that connect the MSPG equipment.

There are two methods of downloading the edid data

It is a VESA regulation. A PC or a MNT will display an optimal resolution through information

Sharing without any necessity of user input. It is a realization of "Plug and Play"

3.5.1. 1st Method

EDID data's are automatically downloaded when adjusting the Tool Options.

Automatically downloaded when pushing the enter key in the EDID D/L menu.

It takes about 2seconds.

3.5.2. 2nd Method

(Caution)

Must be checked that the tool option is right or not.

If tool option is wrong, HDMI edid data could not be downloaded well.

- (1) Press the ADJ key
- (2) Move to the 13. EDID D/L and Press the right direction key(▶)
- (3) Press the right direction key(▶) at Start.
- (4) After about a few seconds, appear "Waiting.." => "OK", then complete.

3.5.3. RS-232C command Method

- (1) Command : AE 00 10

(Caution)

Don't connect HDMI and RGB(D-SUB) cable when downloading the EDID.

If the cables are connected, Downloading of edid could be failed.

3.5.4. EDID data

3.5.4.1. DTS

Input	3D			
	6G		3G	
HDMI 1	9F	65	9F	8B
HDMI 2	9F	55	9F	7B
HDMI 3	9F	45	9F	6B

(1) 3D_6G

- HDMI1 6G_UHD Deep Color ON

Table with 16 columns (0-F) and 16 rows (0-F) showing hex values for HDMI1 6G_UHD Deep Color ON.

- HDMI2 6G_UHD Deep Color ON

Table with 16 columns (0-F) and 16 rows (0-F) showing hex values for HDMI2 6G_UHD Deep Color ON.

- HDMI3 6G_UHD Deep Color ON

Table with 16 columns (0-F) and 16 rows (0-F) showing hex values for HDMI3 6G_UHD Deep Color ON.

(2) 3D_3G

- HDMI1 3G_UHD Deep Color ON

Table with 16 columns (0-F) and 16 rows (0-F) showing hex values for HDMI1 3G_UHD Deep Color ON.

- HDMI2 3G_UHD Deep Color ON

Table with 16 columns (0-F) and 16 rows (0-F) showing hex values for HDMI2 3G_UHD Deep Color ON.

- HDMI3 3G_UHD Deep Color ON

Table with 16 columns (0-F) and 16 rows (0-F) showing hex values for HDMI3 3G_UHD Deep Color ON.

3.6. ADC Calibration

Comp 480i/Comp 1080p/RGB

3.6.1. ADC Calibration : Internal Auto ADC

ADC calibration is not necessary because MAIN SoC (LGExxxx) is already calibrated from IC Maker

3.6.2. Manual ADC Calibration

3.6.2.1. Equipment & Condition

- (1) Adjustment Remocon
- (2) 801GF (802B, 802F, 802R) or MSPG925FA Pattern Generator
 - Resolution : 480i Comp1 (MSPG-925FA: model-209, pattern-65)
 - Resolution : 1080p Comp1 (MSPG-925FA: model-225, pattern-65)
 - Resolution : 1080p RGB (MSPG-925FA: model-225, pattern-65)
 - Pattern : Horizontal 100% Color Bar Pattern
 - Pattern level: 0.7±0.1 Vp-p

3.6.2.2. Adjust method

3.6.2.2.1. ADC 480i/1080p Comp

- (1) Check connected condition of Comp cable to the equipment
- (2) Give a 480i Mode, Horizontal 100% Color Bar Pattern to Comp1. (MSPG-925FA -> Model: 209, Pattern: 65)
- (3) Change input mode as Component1 and picture mode as "Standard"
- (4) Press the In-start Key on the ADJ remote after at least 1 min of signal reception. Then, select
- (5) External ADC. And Press OK or Right Button for going to sub menu.
- (6) Press OK in Comp 480i menu
- (7) Give a 1080p Mode, Horizontal 100% Color Bar Pattern to Comp1. (MSPG-925FA -> Model: 225, Pattern: 65)
- (8) Press OK in Comp 1080p menu
- (9) If ADC Comp is successful, "ADC Component Success" is displayed.
- (10) If ADC calibration is failure, "ADC Component Fail" is displayed.
- (11) If ADC calibration is failure, after rechecking ADC pattern or condition, retry calibration
- (12) If ADC calibration is failure, after recheck ADC pattern or condition, retry calibration

3.7. Check SW Version

3.7.1. Method

- (1) Push In-star key on Adjust remote-controller.
- (2) SW Version check

IN START		Adjust Check	
Model Name :	49UH9300-NA	1.Adjust Check	Adjust Check
Serial Number :	012PTED6N500	2.ADC Data	Country Group
SiW Version :	3.02.06.01	3.Power Off Status	Country Group Code
MICOM Version :	3.05.3	4.System1	Country Group
BOOT Version :	1.02.22	5.System2	Country
UHD BE Version :	OK(40.00.1b.00)	6.System3	Area Option
Chip Type :	LG1312	7.Model Number D/L	Tool Option
Wi-Fi Channel :	1	8.Test Option	Tool Option1
Wi-Fi MAC :	E8:F2:E2:69:06:CA	9.Spread Spectrum	Tool Option2
Wi-Fi Speed :	USB 2.0	10.Stable Count	Tool Option3
MAC Address :	3C:CD:93:4F:CB:5D	11.SDP Server Selection	Tool Option4
IP Address :	0.0.0.0	12.RF Remocon Test	Tool Option5
SFU Key :	OK	13.Access Code	Tool Option6
Widevine :	LGTV10L000011618	14.Twin TV	Tool Option7
ESN Num. :	LGTV20162=21001000272		Tool Option9
HDCP1.4 :	OK		Tool CRC
HDCP2(Miracast/HDMI) :	OK/OK		Adjust White Balance :
DTCP :	OK		Adjust ADC(OTP):
RF Receiver Version :	1.3.4.18		Component
Wi-Fi/Magic Search :	OK/OK		EDID:
Camera Ver. :	NULL		HDMI1
Debug Status :	Release		HDMI2
SIGN Key :	DEVELKEY		HDMI3
Eye Check :	OK		
Control Key :	OK		
Access USB Status :	1/-(-T) / -(-C)		
UTT : 40	75		
APP History Version	146(deathvalley)		
PQL DB :	LGD_EGDE_Si2178B_XXXX55		
Video :	NULL		

3.8. Camera Port Inspection

- (1) Objective : To check PCBA's CAMERA Port.
 - (2) How-it-works
 - 1) Connect the PCBA like below Picture.
 - 2) Send specific RS-232C Command for displaying Camera Preview.
- * CAMERA need to be status of Slide up

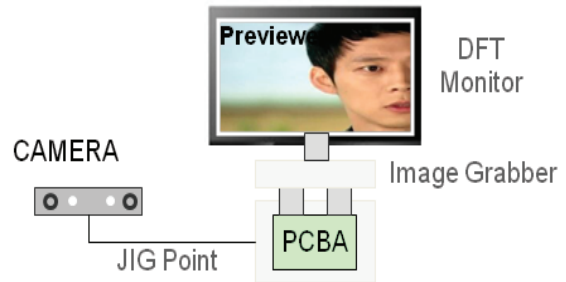

3) RS-232C Command

RS-232C COMMAND			Explanation
CMD	DATA	ID	
Ai	00	23	Camera Function Start.
Ai	00	24	Camera Function End.

4. SET assembly adjustment method

4.1. Input Area-Option

4.1.1. Profile

Must be changed the Area option value because being different of each Country's Language and signal Condition.

4.1.2. Equipment

adjustment remote control.

4.1.3. Adjustment method

- The input methods are same as other chassis.(Use IN-START Key on the Adjust Remocon.)

Refer to Job Expression of each main chassis ass'y (EBTxxxxxxx) for Option value.

4.2. Adjustment of White Balance

* In case of keeping module is in the circumstance of 0°C, it should be placed in the circumstance of above 15°C for 2 hours

* In case of keeping module is in the circumstance of below -20°C, it should be placed in the circumstance of above 15°C for 3 hours.

- Purpose : Adjust the color temperature to reduce the deviation of the module color temperature.
- Principle : To adjust the white balance without the saturation, Fix the one of R/G/B gain to 192 (default data) and decrease the others.
- Adjustment mode : Three modes – Cool / Medium / Warm

* Required Equipment

- Remote controller for adjustment
- Color Analyzer : CA100+ or CA-210 or same product (should be used in the calibrated ch by CS-1000)
 - LCD TV : CH-9
 - PDP TV : CH-10
 - White LED TV : CH-14
 - ALEF : CH-18
 - RGB LED(MNT) : CH-16
 - Auto W/B adjustment instrument(only for Auto adjustment)

4.2.1. Adjustment of White Balance (For Automatic Adjustment)

Connecting diagram of equipment for measuring (For Automatic Adjustment)

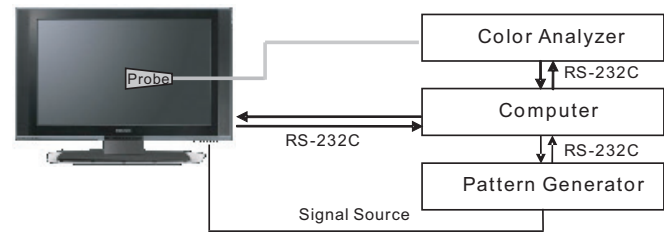

* If TV internal pattern is used, not needed

- (1) Set TV in ADJ mode using P-ONLY key (or POWER ON key)
- (2) Place optical probe on the center of the display
- (3) It need to check probe condition of zero calibration before adjustment.
- (4) Connect RS-232C Cable
- (5) Select mode in ADJ Program and begin a adjustment.
- (6) When WB adjustment is completed with OK message, check adjustment status of pre-set mode (Cool, Medium, Warm)
- (7) Remove probe and RS-232C cable.

- W/B Adj. must begin as start command "wb 00 00" , and finish as end command "wb 00 ff", and Adj. offset if need

4.2.2. Adjustment of White Balance (for Manual adjustment)

4.2.1.1. Adj. condition and cautionary items

- (1) Lighting condition in surrounding area surrounding lighting should be lower 10 lux. Try to isolate adj. area into dark surrounding.
- (2) Probe location: Color Analyzer (CA-210) probe should be within 10cm and perpendicular of the module surface (80°~100°)
- (3) Aging time
 - 1) After Aging Start, Keep the Power ON status during 5 Minutes.
 - 2) In case of LCD, Back-light on should be checked using no signal or Full-white pattern.

4.2.2.2. Equipment

- (1) Color Analyzer: CA-210 (NCG: CH 9 / WCG: CH12 / LED: CH14)
- (2) Adj. Computer (During auto adj., RS-232C protocol is needed)
- (3) Adjust Remocon
- (4) Video Signal Generator MSPG-925F 720p/216-Gray (Model: 217, Pattern: 78)

4.2.2.3. Adjustment

- (1) Set TV in Adj. mode using POWER ON
- (2) Zero Calibrate the probe of Color Analyzer, then place it on the center of LCD module within 10cm of the surface.
- (3) Press ADJ key -> EZ adjust using adj. R/C -> 6. White-Balance then press the cursor to the right (KEY▶). When KEY(▶) is pressed 216 Gray internal pattern will be displayed.
- (4) One of R Gain / G Gain / B Gain should be fixed at 192, and the rest will be lowered to meet the desired value.
- (5) Adj. is performed in COOL, MEDIUM, WARM 3 modes of color temperature.

▪ If internal pattern is not available, use RF input. In EZ Adj. menu 6.White Balance, you can select one of 2 Test-pattern: ON, OFF. Default is inner(ON). By selecting OFF, you can adjust using RF signal in 216 Gray pattern.

4.2.3. LED White balance table

4.2.3.1. Cool Mode

- (1) Purpose : Especially G-gain fix adjust leads to the luminance enhancement. Adjust the color temperature to reduce the deviation of the module color temperature.
- (2) Principle : To adjust the white balance without the saturation, Adjust the G gain more than 172 (If R gain or G gain is more than 255 , G gain can adjust less than 172) and change the others (R/B Gain).
- (3) Adjustment mode : mode – Cool

5.2.3.2. Medium / Warm Mode

- (1) Purpose : Adjust the color temperature to reduce the deviation of the module color temperature.
- (2) Principle : To adjust the white balance without the saturation,Fix the one of R/G/B gain to 192 (default data) and decrease the others.
- (3) Adjustment mode : Two modes – Medium / Warm

▪ Standard color coordinate and temperature when using the CA210 equipment(CH 14)

Mode	Coordinate		Temp	Δuv
	X	Y		
Cool	0.271±0.002	0.270±0.002	13000K	0.0000
Medium	0.286±0.002	0.289±0.002	9300K	0.0000
Warm	0.313±0.002	0.329±0.002	6500K	0.0000

- The Time Table of color coordinates by SET Aging Time
- (1) Edge LED Models(UH8/UH9)_nomarl line

	Aging time (Min)	Cool		Medium		Warm	
		X	Y	X	Y	X	Y
		271	270	286	289	313	329
1	0-2	282	289	297	308	324	348
2	3-5	281	287	296	306	323	346
3	6-9	279	284	294	303	321	343
4	10-19	277	280	292	299	319	339
5	20-35	275	277	290	296	317	336
6	36-49	274	274	289	293	316	333
7	50-79	273	272	288	291	315	331
8	80-119	272	271	287	290	314	330
9	Over 120	271	270	286	289	313	329

▪ In the SET applied LED module (LM9600), cause of the physical characteristics of LED Module, sets are taken a 120 minutes by aging time to stabilize a color coordinates. So White Balance Control equipments have to get the SET Aging Time from the SET and then going to control the W/B by revise color coordinates at each time

- To check the Coordinates of White Balance, you have to measure at the below conditions.

Picture Mode : select Vivid and change

Dynamic Contrast : Off ,

Dynamic Colour : Off,

Clear White : Off

-> Picture Mode change : Vivid -> Vivid(User)

(If you miss the upper condition, the coordinates of W/B can be lower than the spec.)

4.4. LAN Inspection

- (1) LAN Port connection with PCB
- (2) Network setting at MENU Mode of TV
- (3) Setting automatic IP
- (4) Setting state confirmation
- (5) If automatic setting is finished, you confirm IP and MAC Address

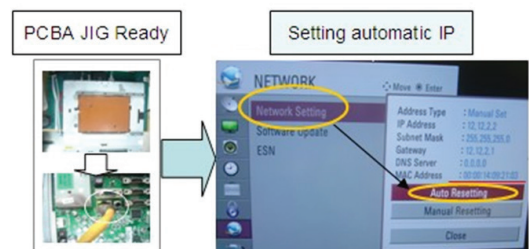

4.5. WIDEVINE Key Inspection

(1) Confirm Key input Data at the "IN START" MENU Mode

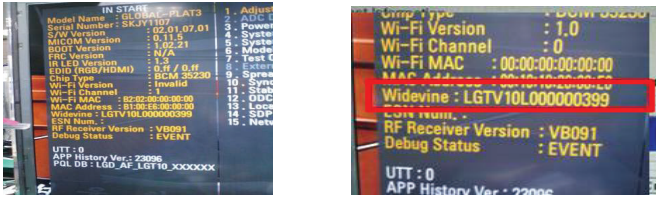

4.6. Model name & Serial number D/L

4.6.1. Notice

- (1) Serial number D/L is using of scan equipment.
- (2) Setting of scan equipment operated by Manufacturing Technology Group.
- (3) Serial number D/L must be conformed when it is produced in production line, because serial number D/L is mandatory by D-book 4.0
- (4) Check the model name In-start menu -> Factory name displayed
- (5) Check the Diagnostics (DTV country only) -> Buyer model displayed

4.6.2. Method : Auto

- (1) Press "Power on" key of service remocoon. (Baud rate : 115200 bps)
- (2) Connect RS232 Signal Cable to RS-232 Jack
- (3) Write Serial number by use RS-232.
- (4) Must check the serial number at Instart menu.

4.6.3. Method : Manual

* If the TV set is downloaded By OTA or Service man, Sometimes model name or serial number is initialized. (Not always) It is impossible to download by bar code scan, so It need Manual download.

- (1) Press the 'instart' key of ADJ remote controller.
- (2) Go to the menu '6. Model Number D/L' like below photo.
- (3) Input the Factory model name or Serial number like photo.

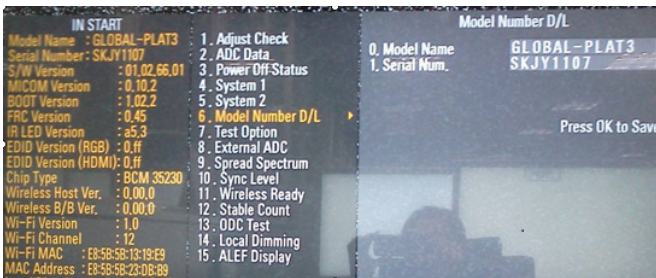

4.7. Wi-Fi MAC Address Check

4.7.1. Using RS232 Command

	Command	Set ACK
Transmission	[A][!][Set ID][20][Cr]	[O][K][x] or [N][G]

4.7.2. Check the menu on in-start



4.8. Local Dimming Inspection (Optional)

4.8.1. ALEF models with local dimming

- (1) Press 'TILT' key of the Adj. R/C and check moving patterns. The black bar patterns moves from top left to bottom right. If local dimming function does not work, a whole screen shows full white.

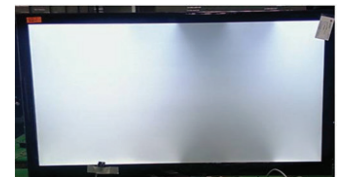
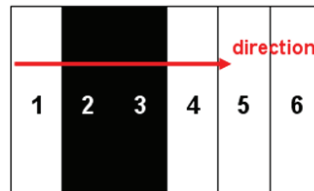

4.9. GND and Hi-Pot test

4.9.1. GND & HI-POT auto-check preparation

- (1) Check the POWER CABLE and SIGNAL CABLE insertion condition

4.9.2. GND & HI-POT auto-check

- (1) Pallet moves in the station. (POWER CORD / AV CORD is tightly inserted)
- (2) Connect the AV JACK Tester.
- (3) Controller (GWS103-4) on.
- (4) GND Test (Auto)
 - If Test is failed, Buzzer operates.
 - If Test is passed, execute next process (Hi-pot test). (Remove A/V CORD from A/V JACK BOX)
- (5) HI-POT test (Auto)
 - If Test is failed, Buzzer operates.
 - If Test is passed, GOOD Lamp on and move to next process automatically.

4.9.3. Check point

- (1) Test voltage
 - 1) 3 Poles
 - GND: 1.5KVac/min at 100mA
 - SIGNAL: 3KVac/min at 100mA
- (2) TEST time: 1 second
- (3) TEST POINT
 - 1) 3 Poles
 - GND Test = POWER CORD GND and SIGNAL CABLE GND.
 - Hi-pot Test = POWER CORD GND and LIVE & NEUTRAL.
- (4) LEAKAGE CURRENT: At 0.5mArms

4.10. Motion Remote controller Inspection

- (1) Equipment : Motion remote controller for test, IR-KEY-CODE remote controller for test
 - 1) Check battery before test. (Recommend : Change battery for every Lot.)
- (2) Process
 - 1) If you select the 'start key(wheel)' on the controller, you can pairing with the TV SET.
 - 2) You can check the cursor on the TV Screen, when select the 'Wheel Key' on the controller
 - 3) You must remove the pairing with the TV Set by select 'Back + Home Key' on the controller

4.11. AUDIO output check

No	Item	Min	Typ	Max	Unit	Remark
1	Audio practical max Output, L/R (Distortion=10% max Output)	9.0 8.5	10.0 8.10	12.0 9.88	W Vrms	Measurement condition
2	Speaker (8Ω Impedance)		10.0	15.0	W	Measurement condition

*Measurement condition:

- (1) RF input: Mono, 1KHz sine wave signal, 100% Modulation
- (2) CVBS, Component: 1KHz sine wave signal (0.4Vrms)
- (3) RGB PC: 1KHz sine wave signal (0.7Vrms)

4.12. 3D Function test

4.12.1. Equipment

Pattern Generator MSPG-3233, HDMI mode 37, pattern No. 81

4.12.2. Process

- (1) Connect HDMI (HDMI mode 371, Pattern No. 81)

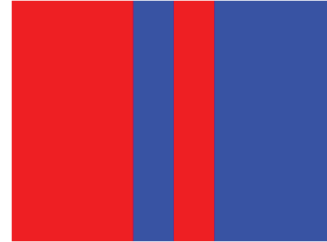

- (2) Insert 3D Mode, Select side by side mode.
- (3) Without 3D-glasses, Like below figure.

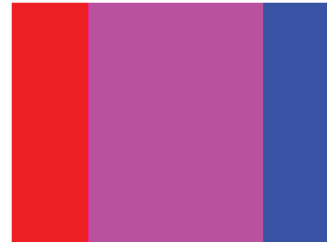

- (4) With 3D left-glass, Like below figure. (Center is RED)



- (5) With 3D right-glass, Like below figure. (Center is Blue)



4.13. HDMI ARC Function Inspection

4.13.1. Test equipment

- Optic Receiver Speaker
- MSHG-600 (SW: 1220 ↑)
- HDMI Cable (for 1.4 version)

4.13.2. Test method

- (1) Insert the HDMI Cable to the HDMI ARC port from the master equipment (HDMI1)
- (2) Check the sound from the TV Set



- (3) Check the Sound from the Speaker or using AV & Optic TEST program (It's connected to MSHG-600)

Flow Line



Cell Line



- * Remark: Inspect in Power Only Mode and check SW version in a master equipment



4.14. Camera Port Inspection

- (1) Objective : To check how it connects between Camera and PCBA normally, and their Function
- (2) Test Method : This Inspection is available only Power-Only Status.
 - 1) Push Camera Up
 - 2) Camera's Preview picture appears on TV Set
- (3) Push Camera Down

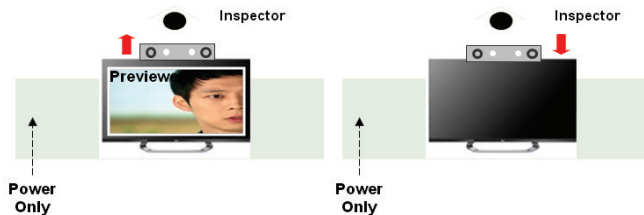

4.15. PIP/W&R Function Inspection

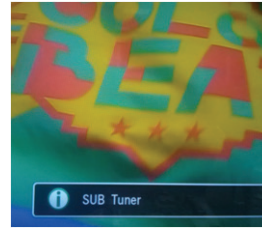

- (1) Objective : To check the connection between sub tuner and PCBA, and their Function
- (2) Test Method : This Inspection is available only Power-Only Status.
 - 1) Press exit key of the Adj. R/C and Press PIP key.
 - 2) Check that the SUB TUNER pop up window on the TV Set.
- (3) Check that the normal operation (picture, sound) of DTV on the TV Set.

** Appendix **

A. DDC Adjustment Command set

	Adjustment content	CMD (HEX)	ADR	VALUE	detail
1	Aging On/Off	F3	00	FF/00	FF : ON / 00 : OFF
2	Input select	F4	00		0x10 : TV 0x20 : AV1 0x21 : AV2 0x40 : Component1 0x41 : Component2 0x60 : RGB 0x90 : HDMI1 0x91 : HDMI2
3	R GAIN	16	00	00 - C0	Gain Value Adjustment CSM COOL
4	G GAIN	18		00 - C0	
5	B GAIN	1A		00 - C0	
6	R GAIN	16	01	00 - C0	Gain Value Adjustment CSM NORMAL
7	G GAIN	18		00 - C0	
8	B GAIN	1A		00 - C0	
9	R GAIN	16	02	00 - C0	Gain Value Adjustment CSM WARM
10	G GAIN	18		00 - C0	
11	B GAIN	1A		00 - C0	
12	CSM mode	F2	00	00	COOL
				01	NORMAL
				02	WARM
13	AUTO ADC	F1	00	0, 1, 2	0: Offset Value Adjustment 1: Gain Value Adjustment 2: Offset and Gain Value Adjustment
14	EEPROM Read	E7	00	00	EEPROM read
15	EEPROM Write	E8	00	data	EEPROM write

B. DDC command protocol

1. Signal TABLE

START 6E A 50 A 84 A 03 A CMD A ADR A VAL A CS A STOP

2. E²PROM Data Write

(1) Signal TABLE

START 6E A 50 A 84+n A 03 A CMD A ADH A ADL A
Data_1 A ... Data_n A CS A STOP Delay 20

LEN : 84h+Bytes

CMD : E8h

ADH : E2PROM Slave Address(A0,A2,A4,A6),
Not 00h(Reserved by BufferToEEPROM)

ADL : E2PROM Sub Address(00~FF)

Data : Write data

Delay : 20ms

(2) Command Set

	Adjustment content	CMD(hex)	LEN	Detail
1	EEPROM READ	E8h	94h	16-Byte Write
2			(84+n)h	n-byte Write

3. E²PROM Data Read

(1) Command Sequential TABLE

START 6E A 50 A 84 A 03 A CMD A ADH A ADL A CS A STOP

Delay 150ms

START 6E A DL A 128 Bytes Dn A STOP

(2) COMMAND SET

No.	Adjustment content	CMD (hex)	ADH (hex)	ADL (hex)	Detail
1	EEPROM READ	E7	A0	0	0-Page 0~7F Read
2				80	0-Page 80~FF Read
3			A2	0	1-Page 0~7F Read
4				80	1-Page 80~FF Read
5			A4	0	2-Page 0~7F Read
6				80	2-Page 80~FF Read
7			A6	0	3-Page 0~7F Read
8				80	3-Page 80~FF Read

C. RS-232C Command Protocol

RS-232C COMMAND			Explanation
CMD	ID	DATA	
wb	00	00	White Balance Adjust Start.
wb	00	10	Gain Adjust Start (Internal white pattern)
wb	00	1f	Gain Adjust Stop.
wb	00	20	Offset Adjust Start. (Internal white pattern)
wb	00	2f	Offset Adjust Stop.
wb	00	ff	White Balance Adjust Stop (Internal pattern Exit)
xb	00		10 : Analog, 20 : Video 1, 21 : Video 2, 40 : Component 1, 41 : Component 2, 50 : RGB_DTV, 60 : RGB_PC 90 : HDMI 1, 91 : HDMI 2, 92 : HDMI
ad	00	10	ADC Start

D. Bluetooth S/W Upgrade by using USB drive Input

(1) Preparation Equipment

1) USB Memory Stick



2) New Bluetooth Software

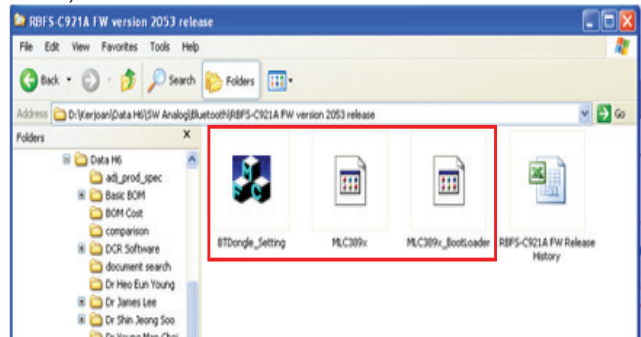

3) Copy New File

Copy Bluetooth software MCL389x.bin file to memory stick with out folder.

(Caution) Do not copy the file to the inside folder

3) Copy New File

Copy Bluetooth software MCL389x.bin file to memory stick with out folder.

(Caution) Do not copy the file to the inside folder

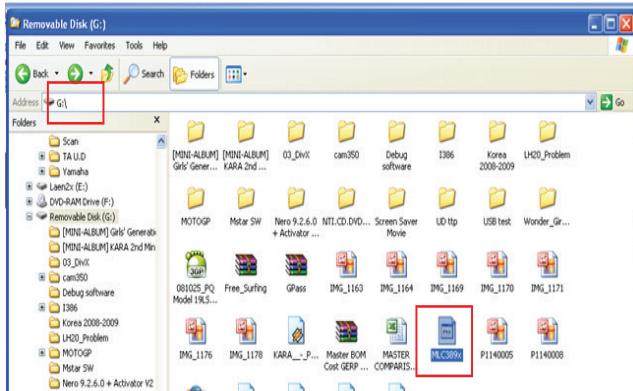

(6) OSD – Bluetooth software updated successfully

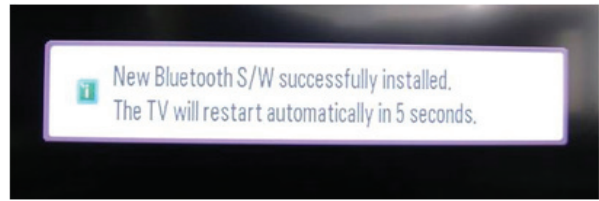

- OSD Information Bluetooth software update success
- LCDTV Set will restart by automatically...
- Time Process to restart about 5seconds

(7) Check S/W Version

- Push “IN-START” button on service remote Controller
 - Check Information Bluetooth S/W version will appear on OSD Service Menu.
- Example : Bluetooth SW version 2.05

(2) Connection

- Plug-in USB Memory stick to the USB input of the set.

(3) USB input -> Automatically loading menu

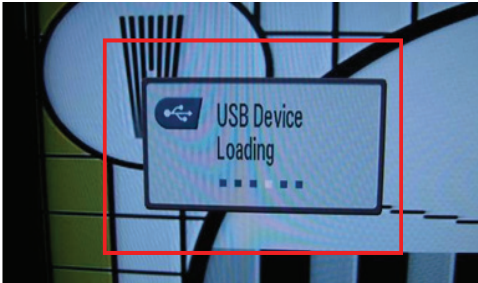

* The OSD “USB Device loading” is appeared by automatically...

(4) Selecting Window for Bluetooth Software update

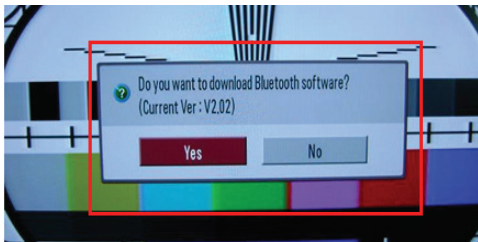

- The Pop-up window appears for selecting to update Bluetooth software and information about current Bluetooth software. (Ex : V2.02)
- Select “Yes”

(5) Bluetooth S/W Downloading Process

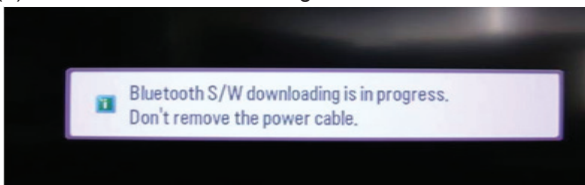

- Time Process Downloading new Bluetooth software about 10seconds
- Please Wait until finish and do not un-plug power cable

Block Diagram

1. M16 + F16 Circuit Block Diagram

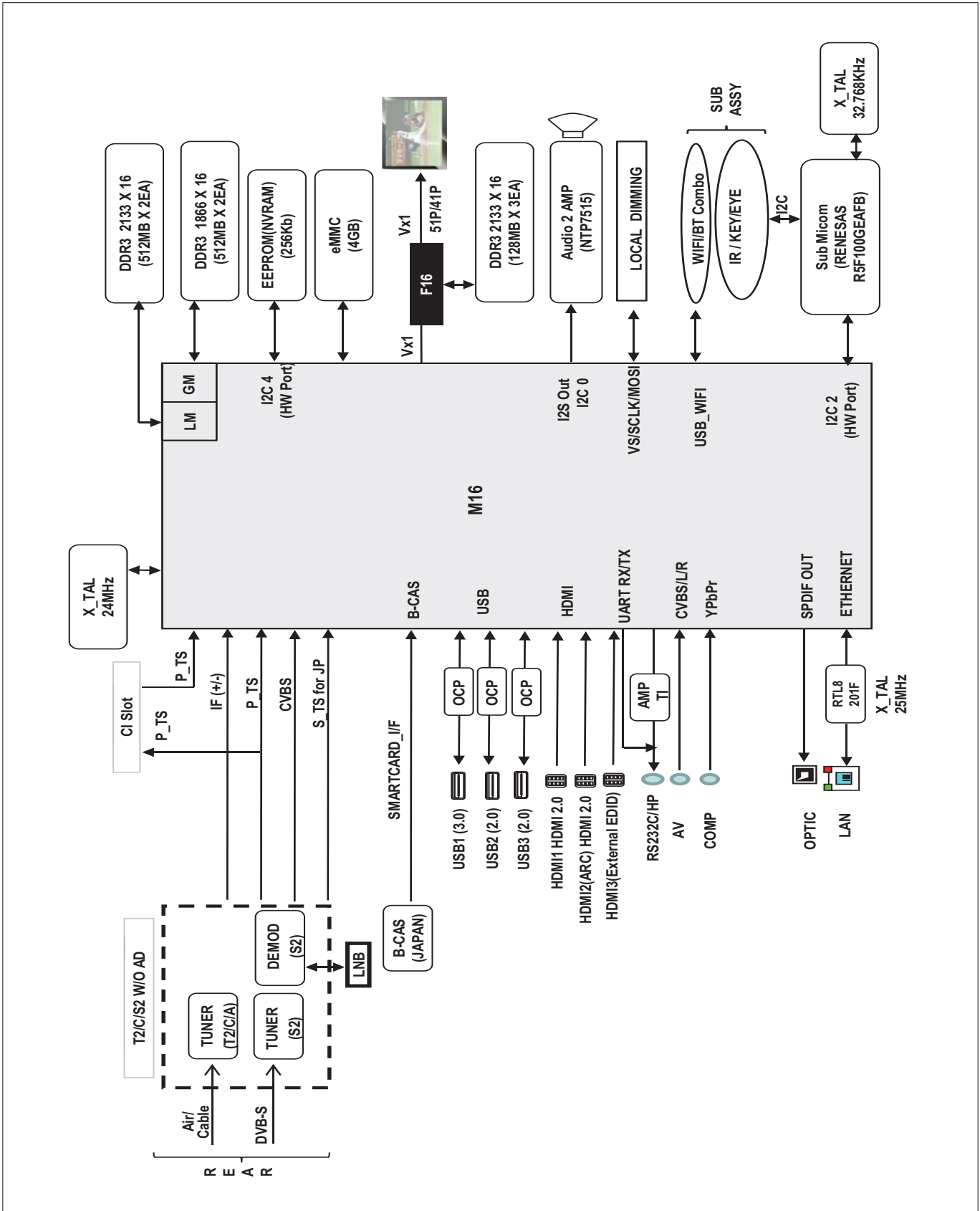

2. M16 + F16 I2C Block Diagram

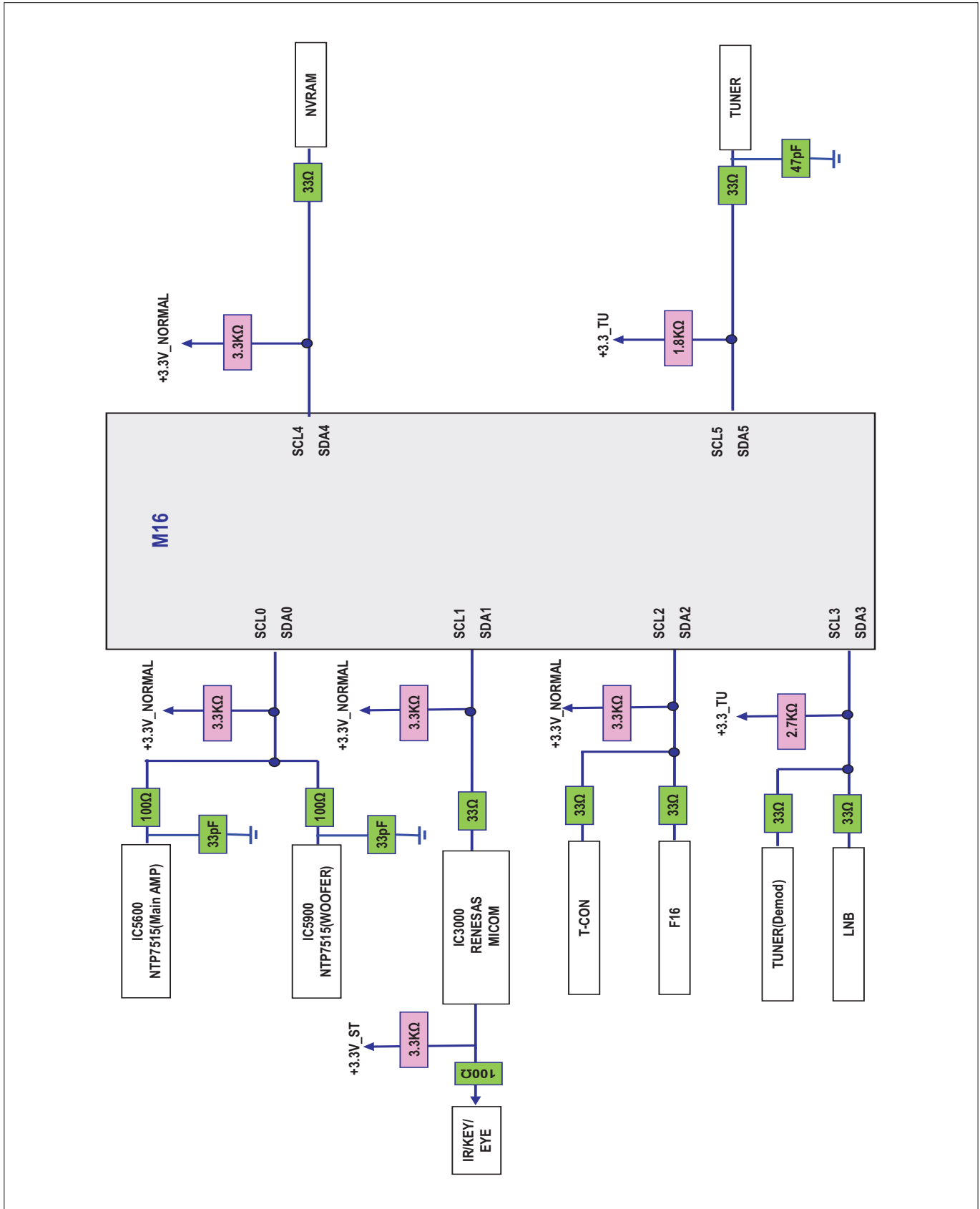

3. F16 Block Diagram

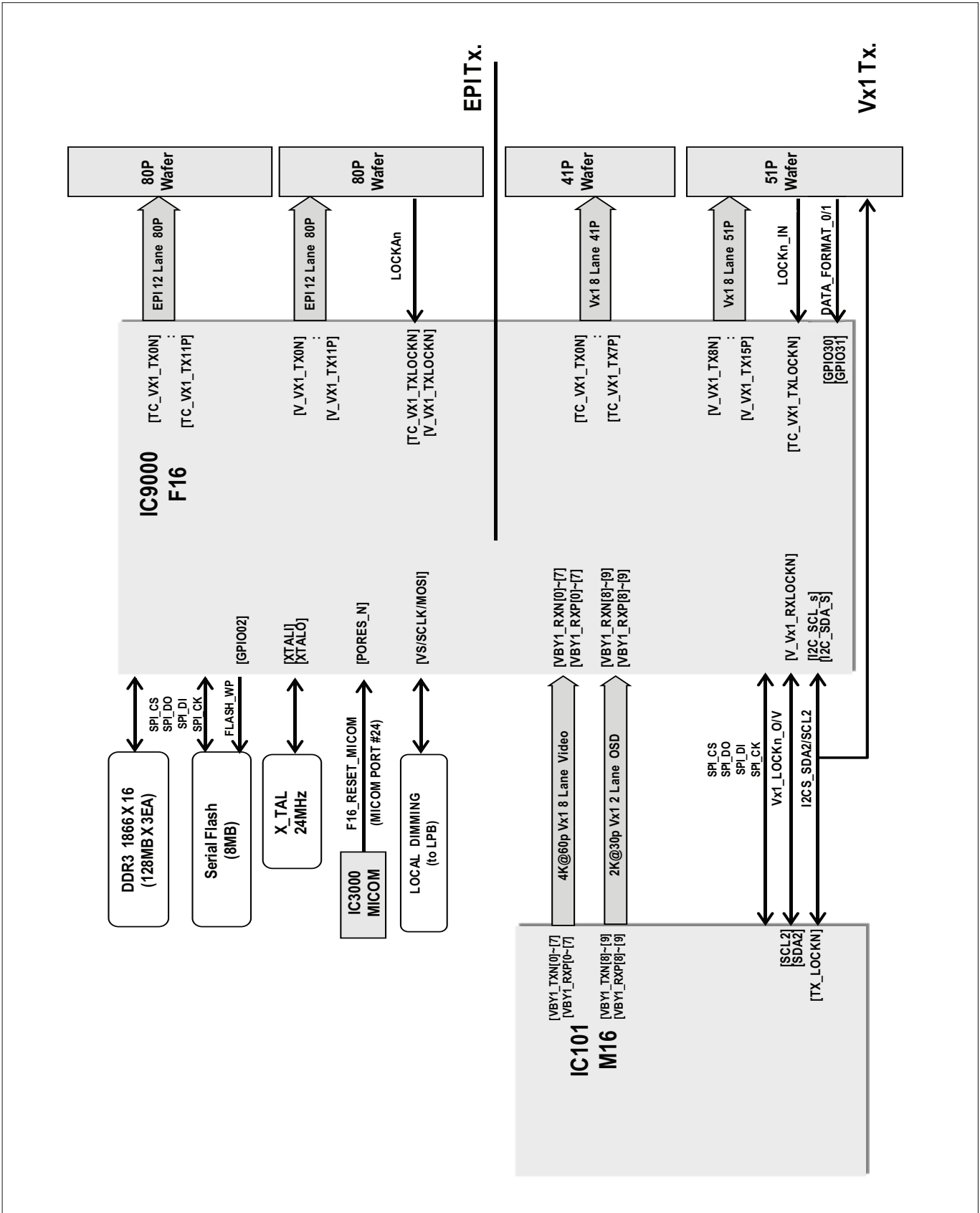

4. M16 Power Block

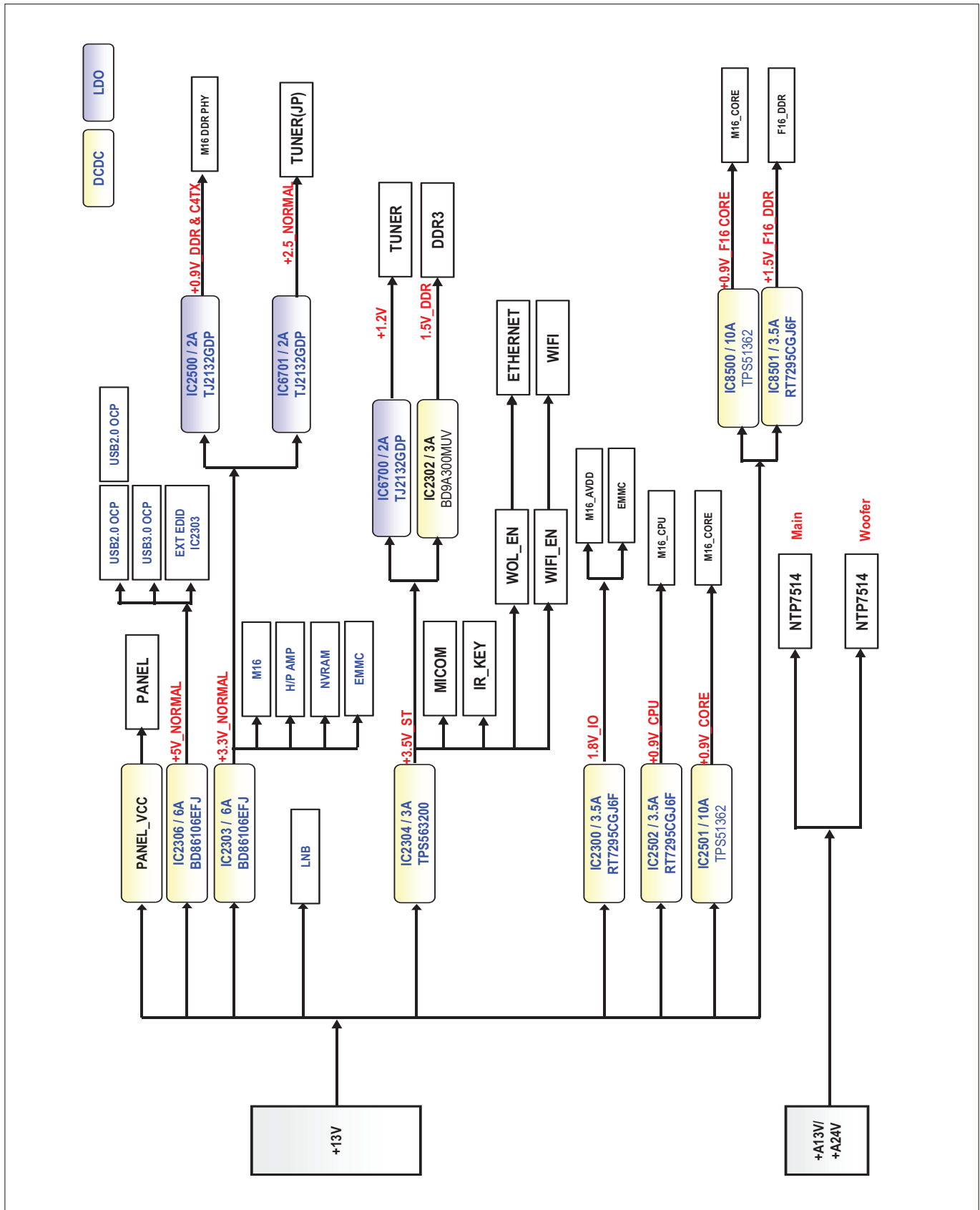

5. Tuner/CI Block Diagram

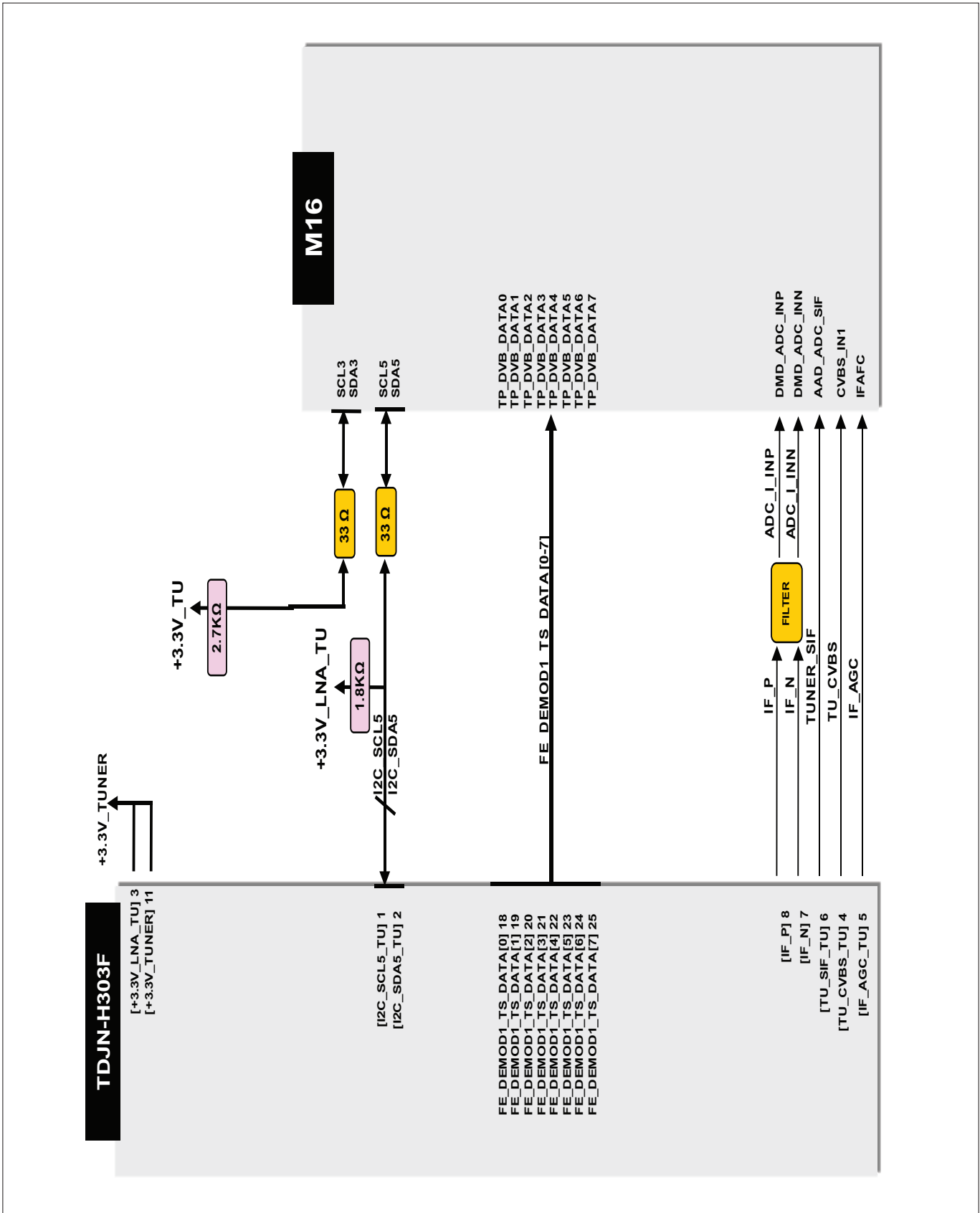

6. Video/Audio In Block Diagram

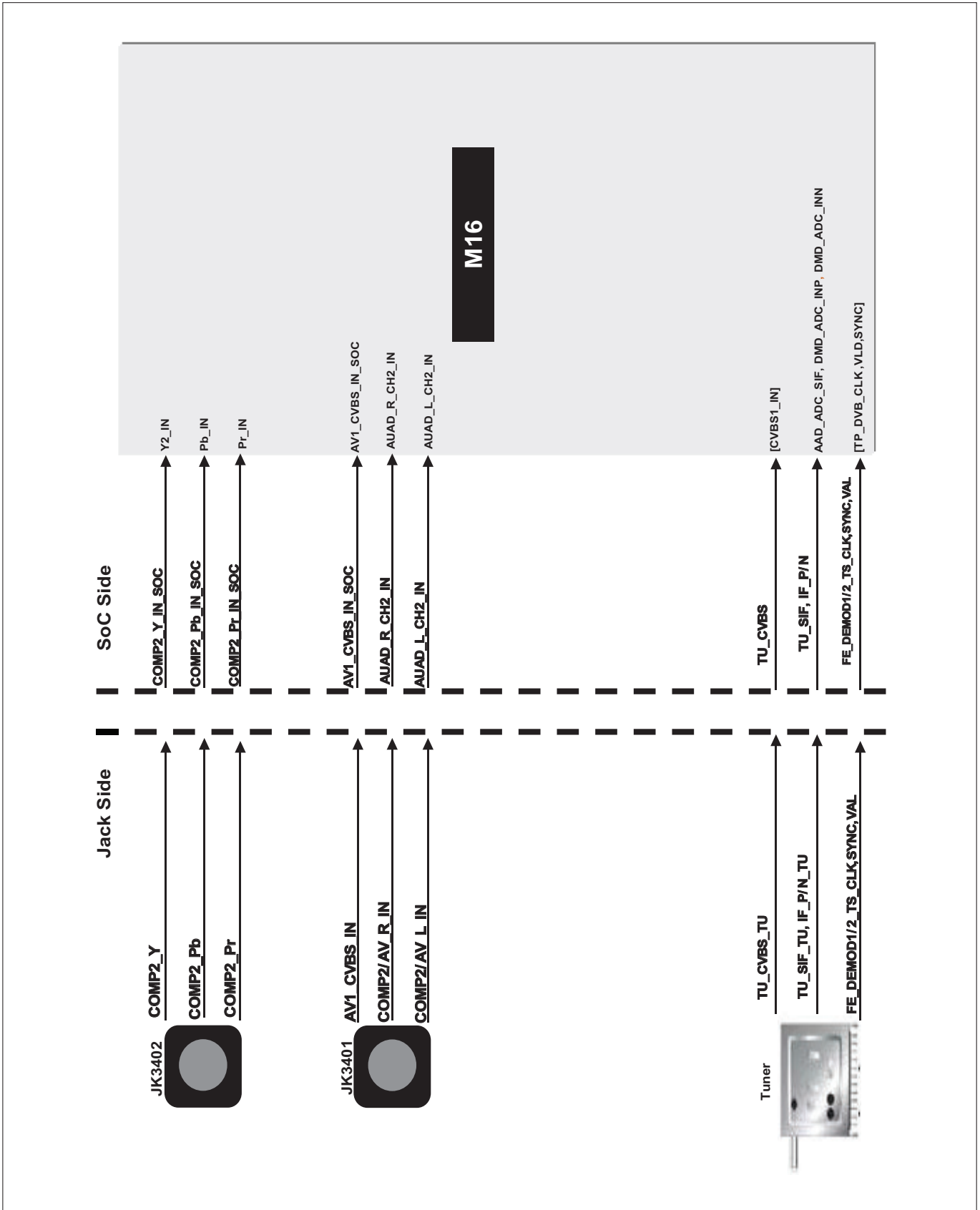

7. Audio Out Block Diagram

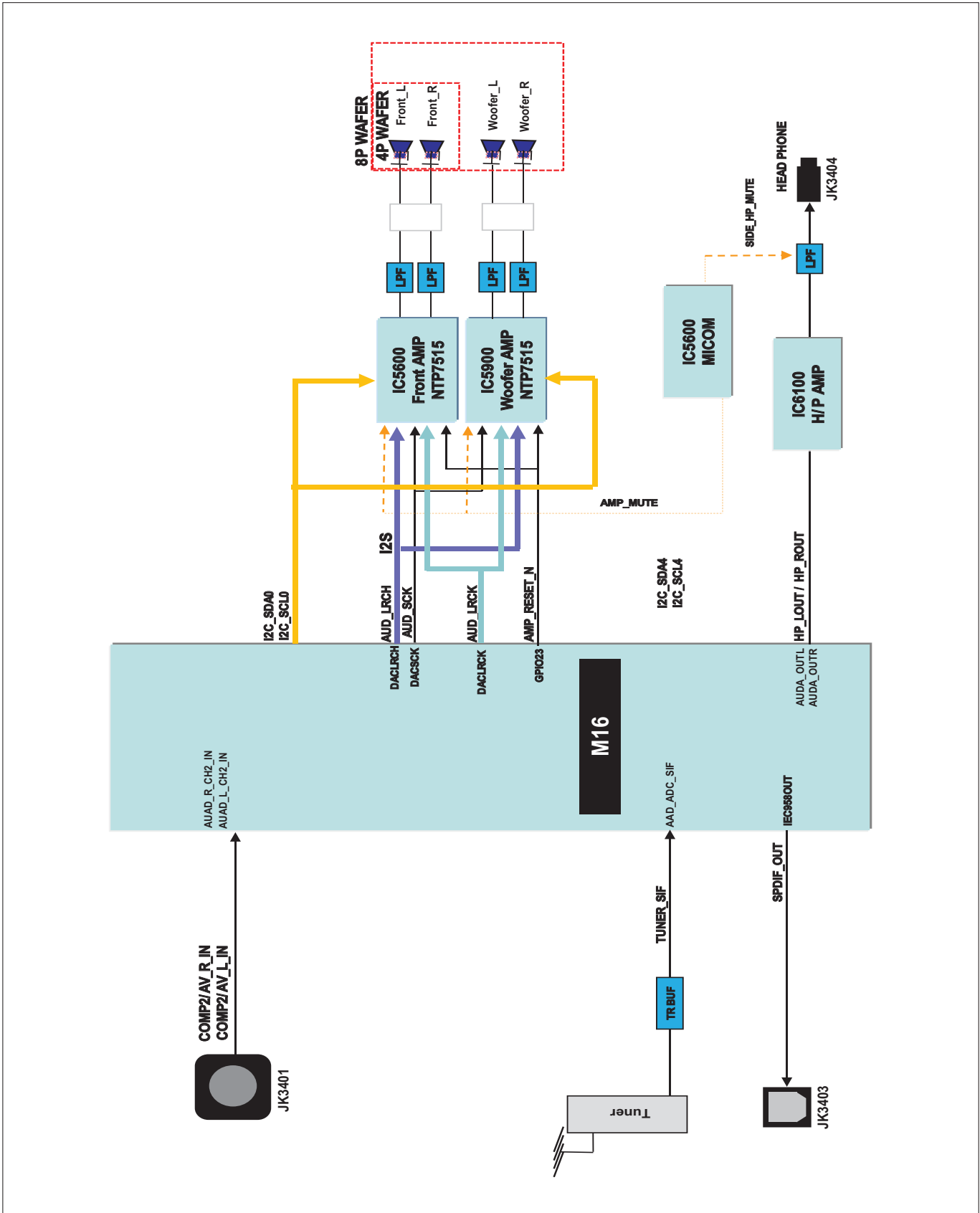

8. HDMI

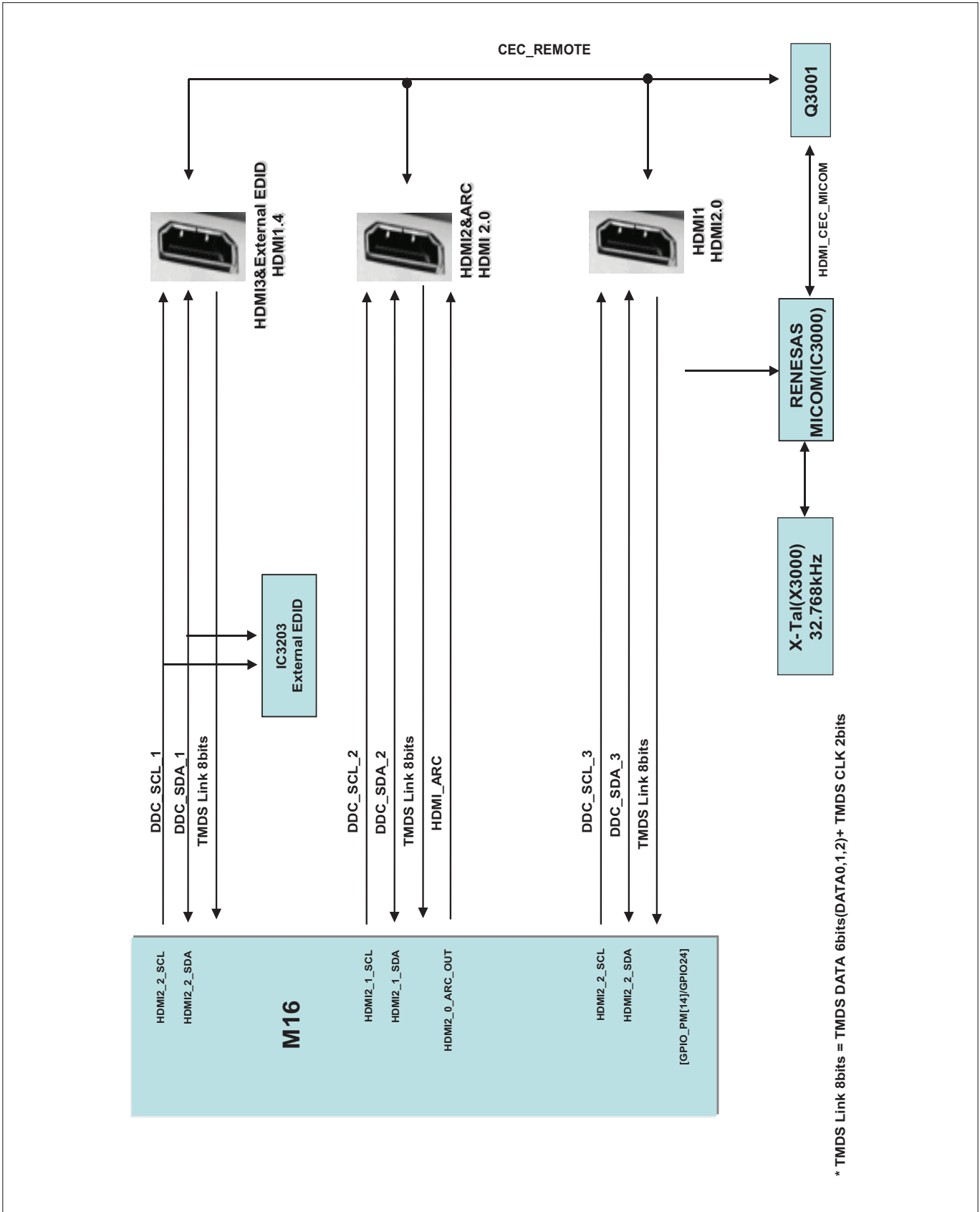

9. USB / WIFI / M-REMOTE / UART

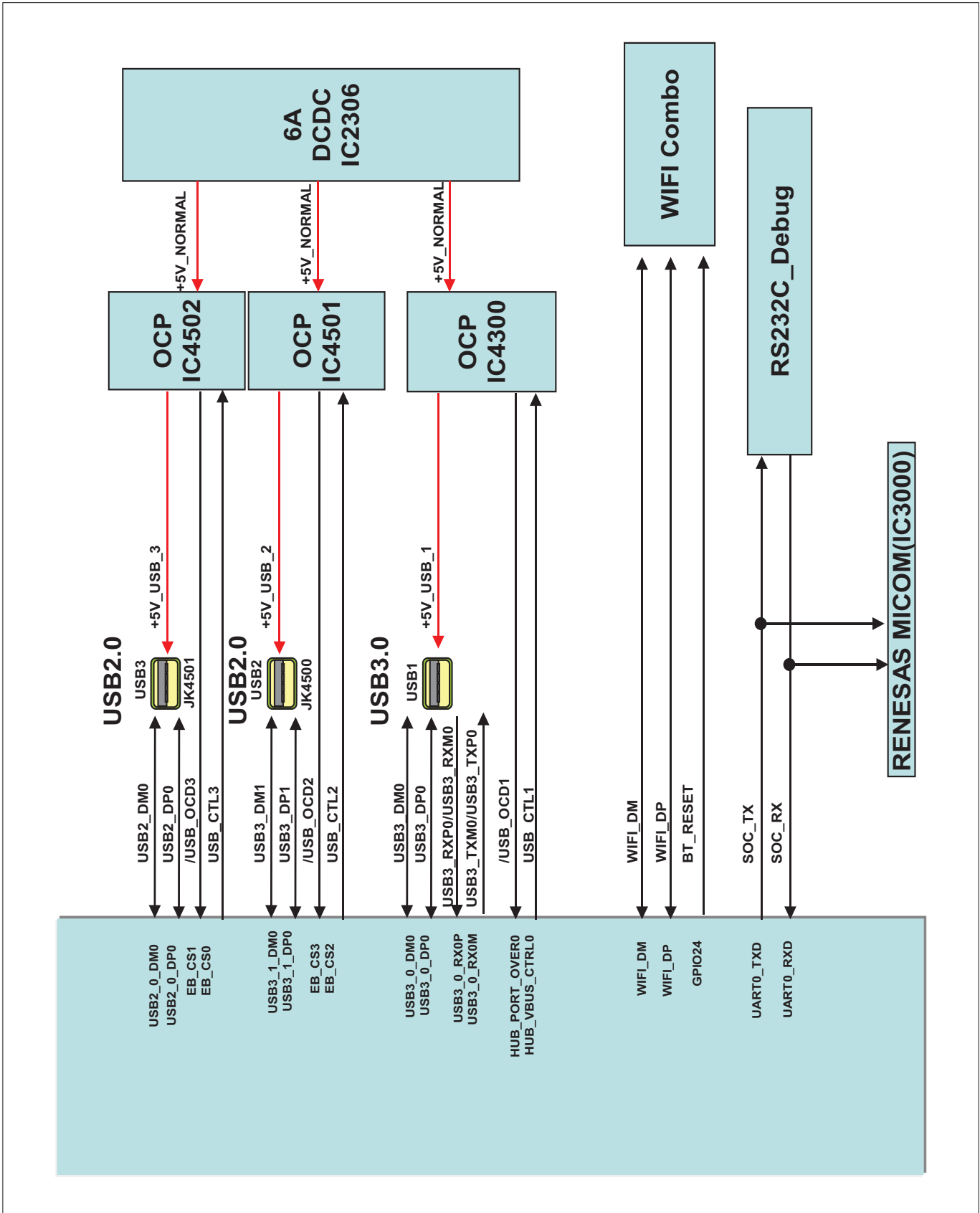

EXPLODED VIEW

IMPORTANT SAFETY NOTICE

Many electrical and mechanical parts in this chassis have special safety-related characteristics. These parts are identified by Δ in the Schematic Diagram and EXPLODED VIEW. It is essential that these special safety parts should be replaced with the same components as recommended in this manual to prevent Shock, Fire, or other Hazards. Do not modify the original design without permission of manufacturer.

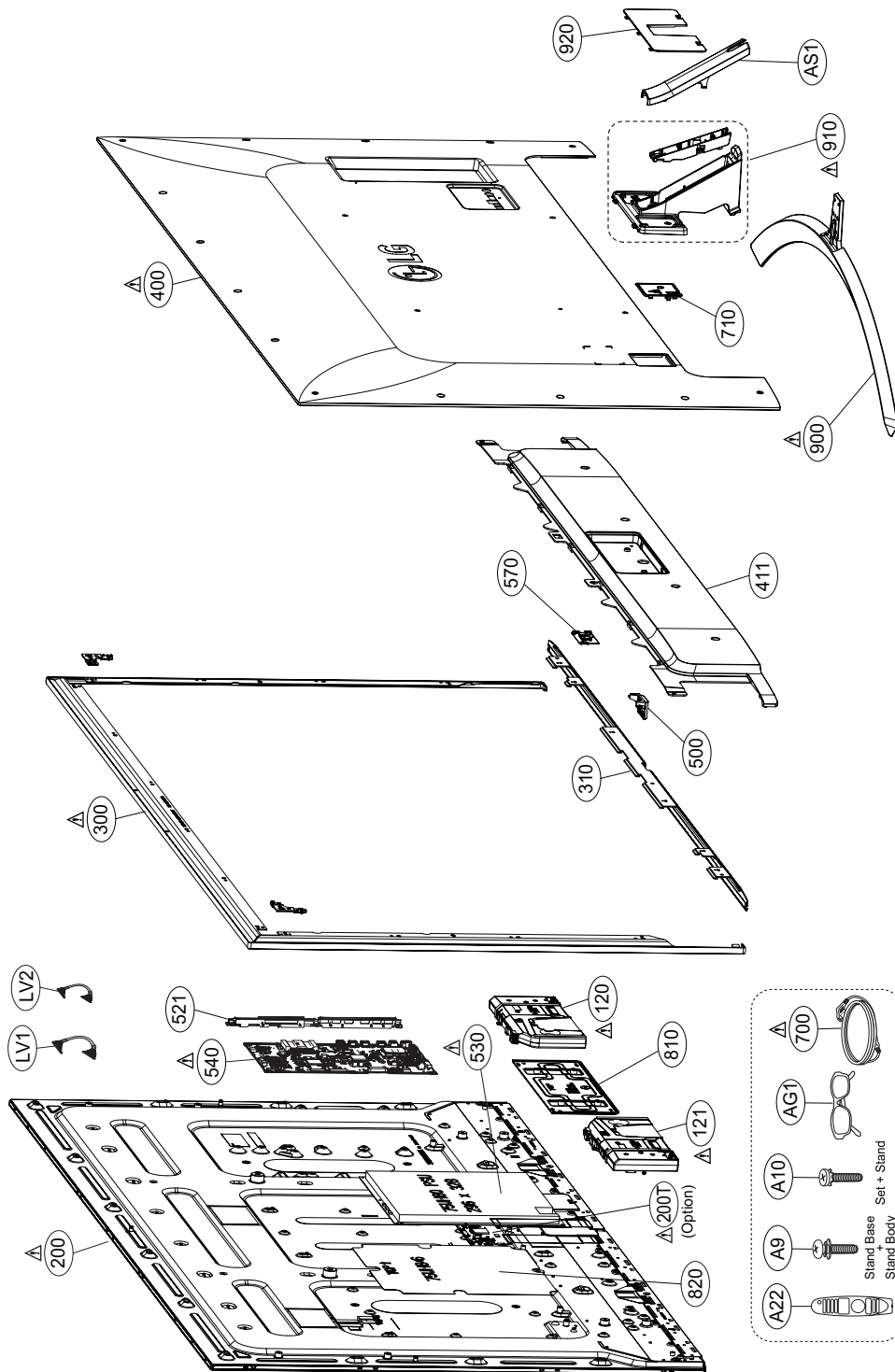

DISASSEMBLY

Unlock screw ("1": 1EA) to separate Power Cord bracket from Back cover assembly
And then Separate connector "1-1" from Power PCB
Separate Dummy Cover("2")

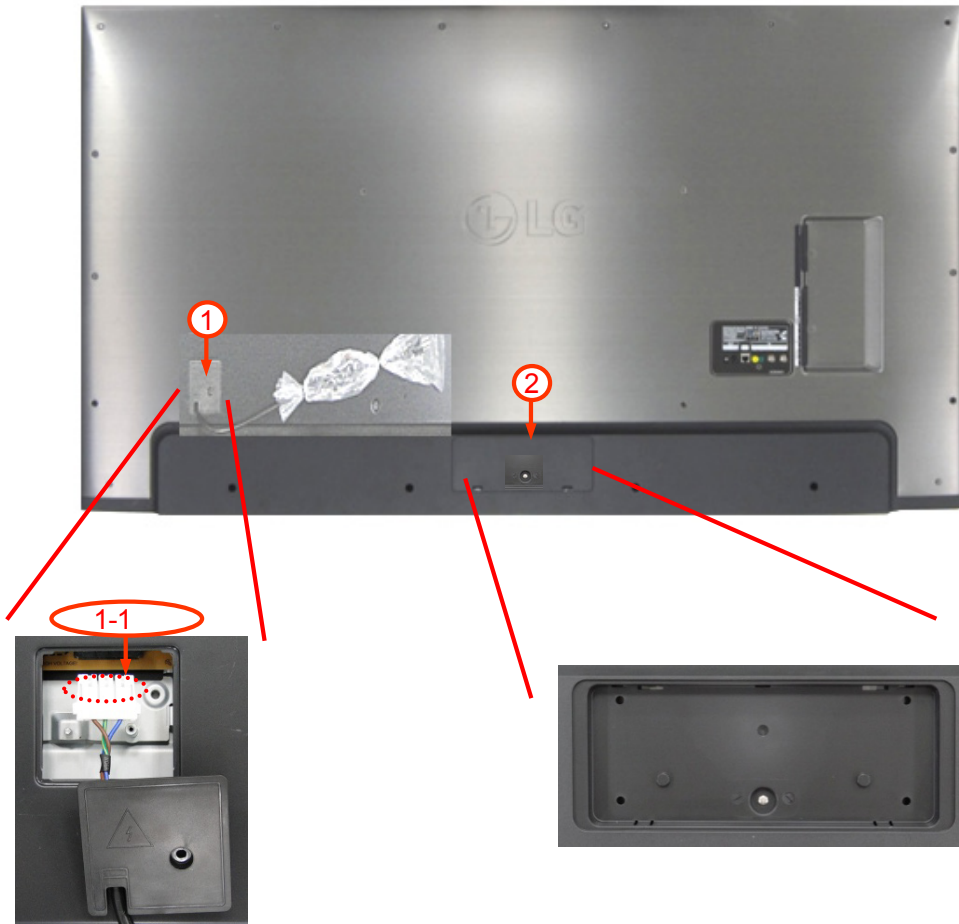

Unlock screw ("3": 21EA, "4": 4EA, "5": 1EA) to separate back cover assembly from module.



Detach Tape ("6": 3EA, "7": 3EA, "8": 8EA)

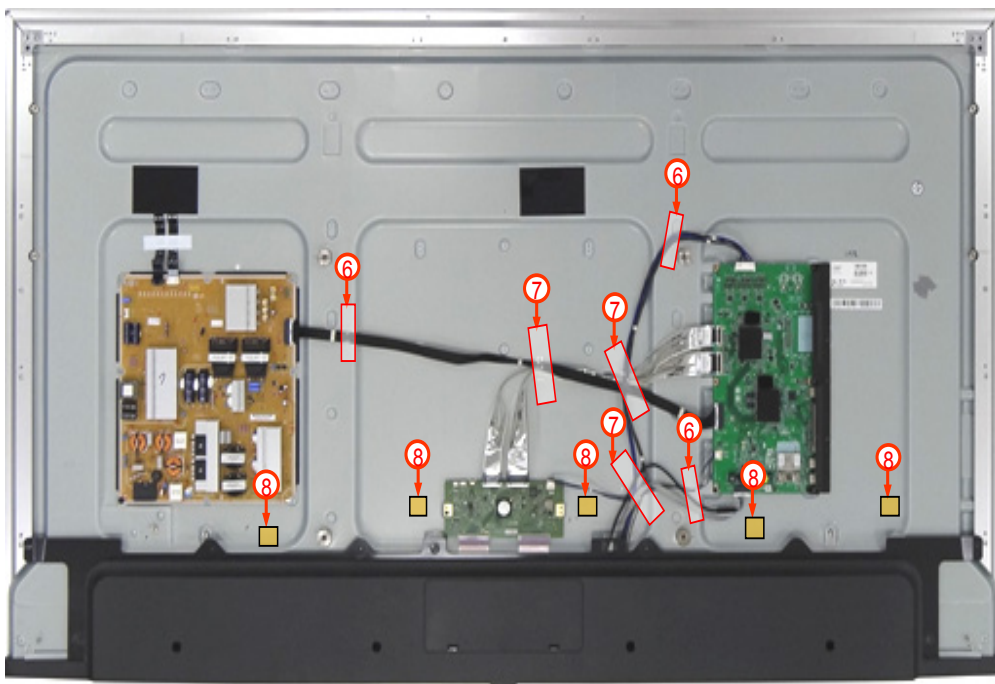

Separate connectors "9" ~ "19" from PCB

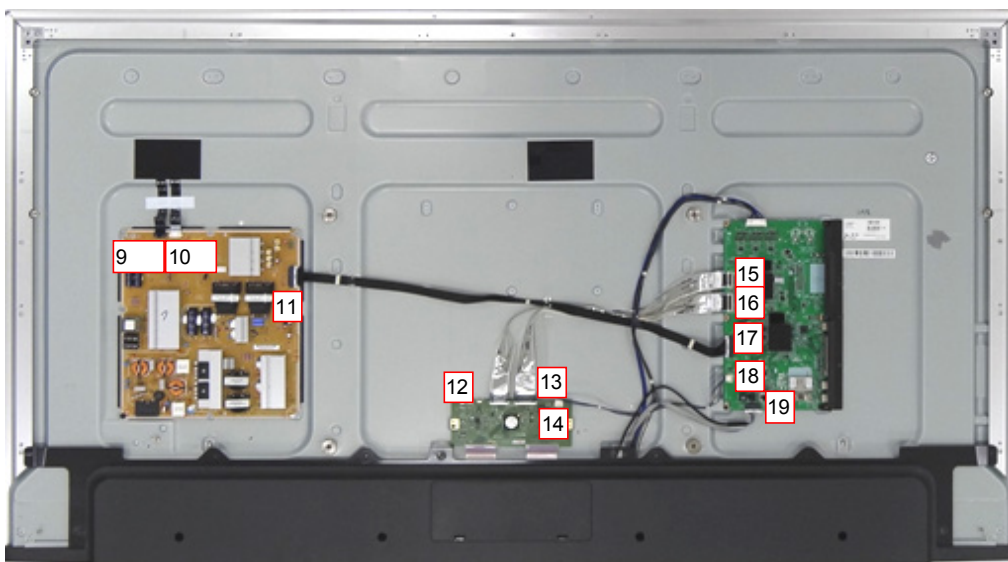

Unlock screw ("a": 17EA, "b": 1EA) to separate from module.
And then separate Main Chassis & Power Chassis from module.
And then separate Middle Cabinet Assy from module

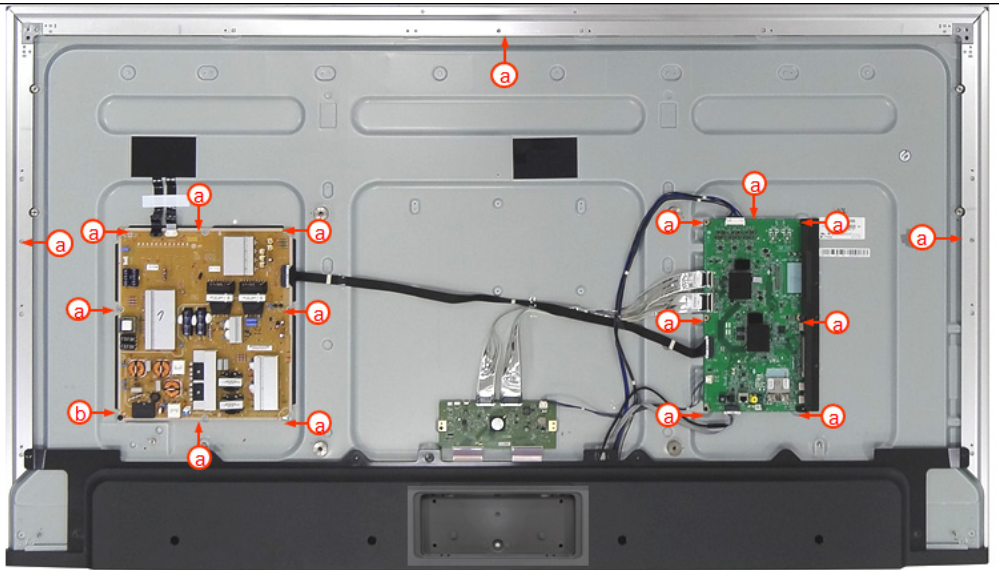

Unlock screw ("c": 4EA) to separate guide from module.
Detach Insulation sheet ("d": 1EA) from Stand module.



Unlock screw ("e": 10EA) and then separate each part.

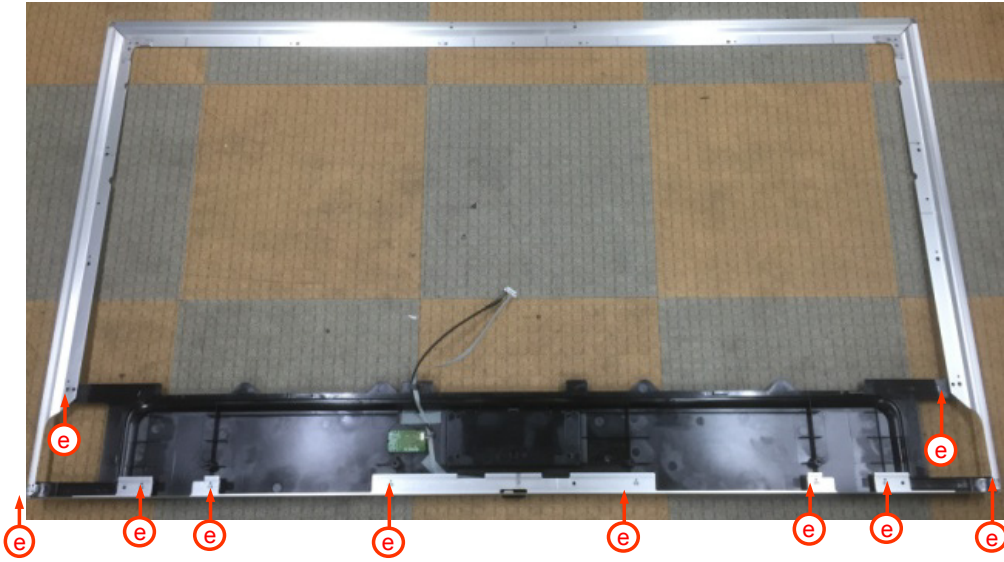

Detach Tape ("f": 2EA)
Unlock screw ("e": 2EA) and then separate each part.

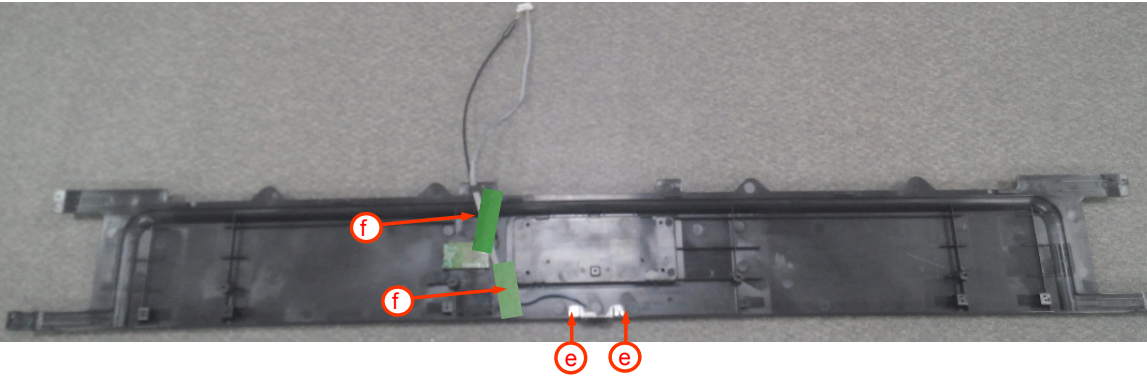

Separate Cable Cover from Body Top

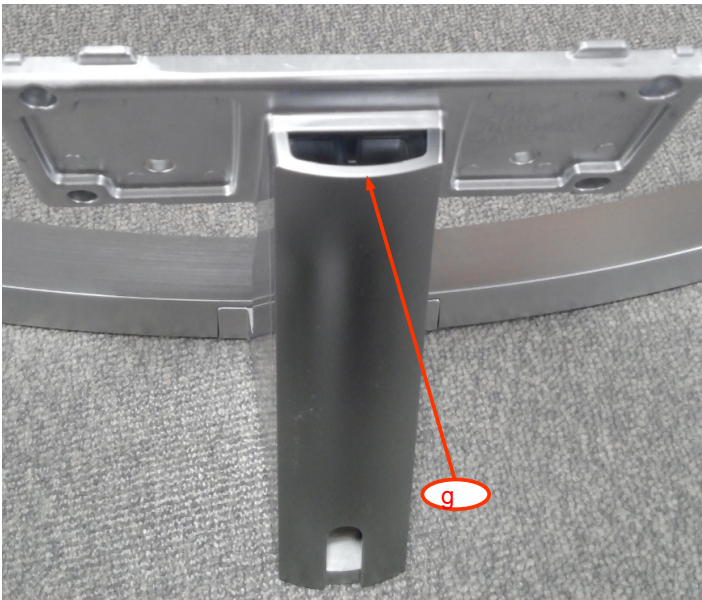

Unlock screw ("h": 2EA) to separate Cable Bracket from Body Top



Unlock screw ("i": 5EA) to separate Stand Top from Stand Base (Left&Right)

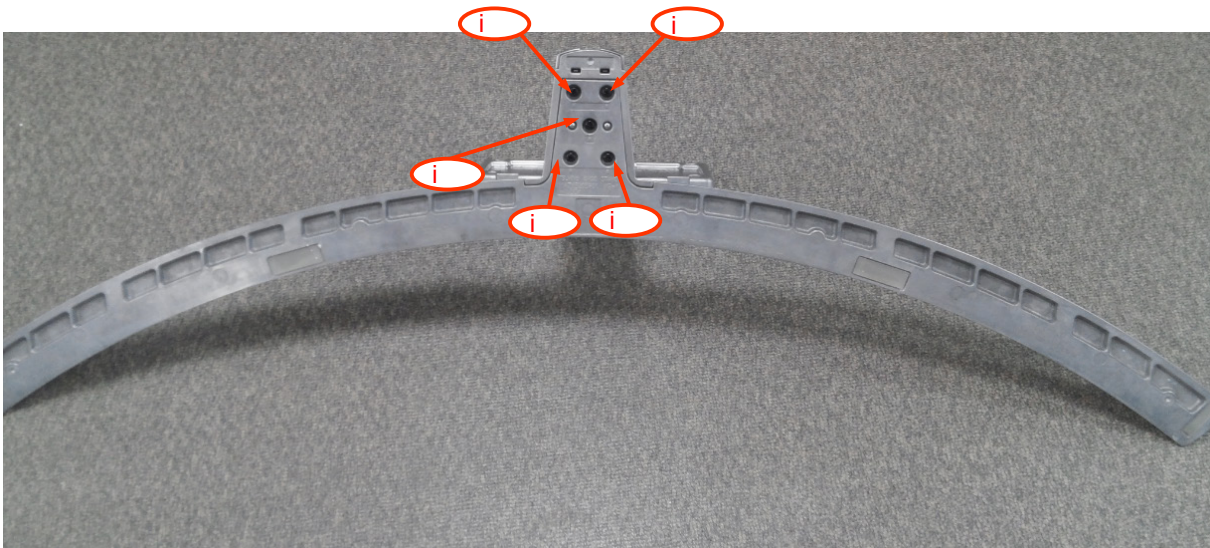

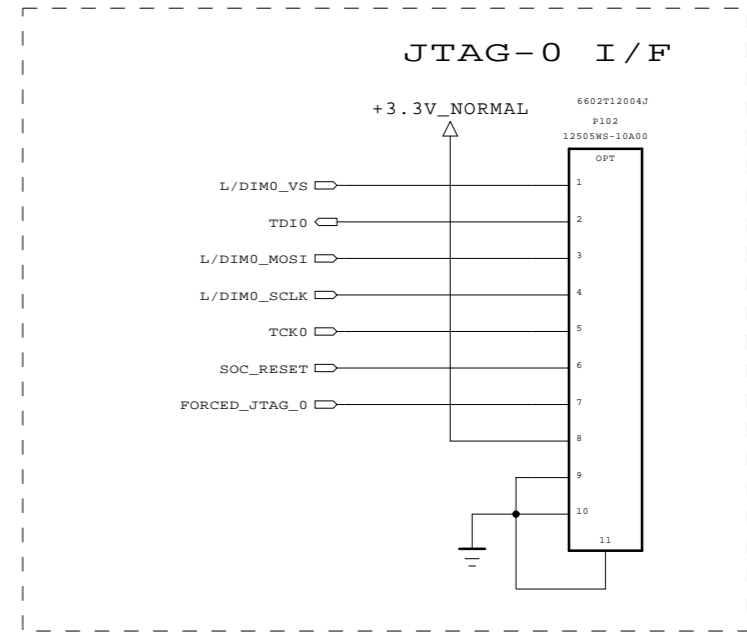
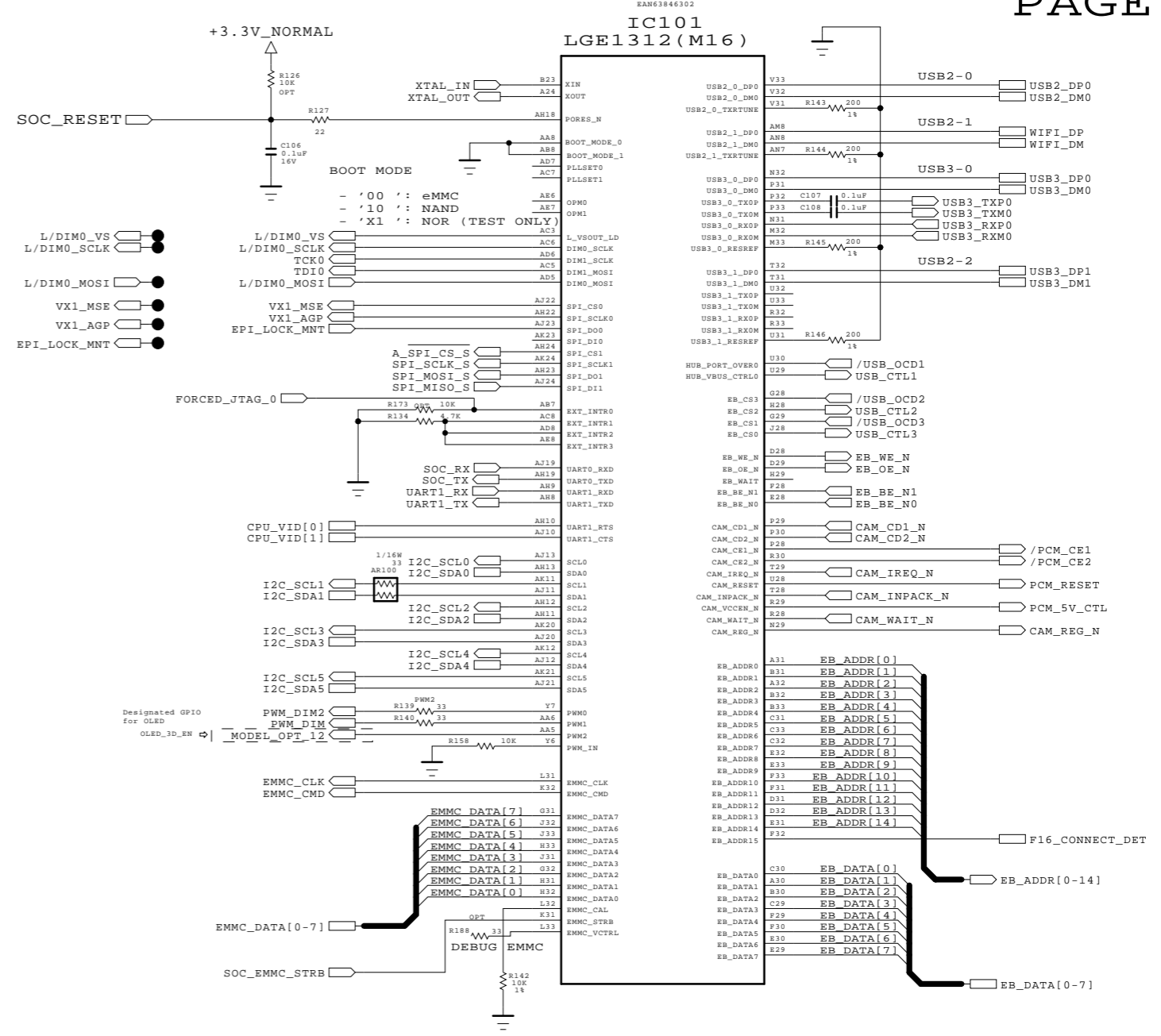
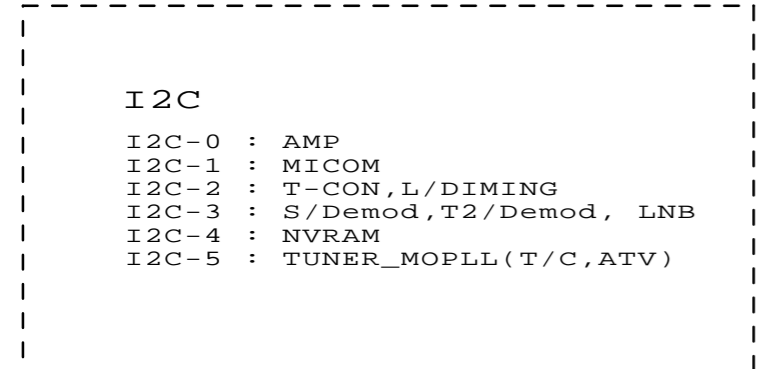
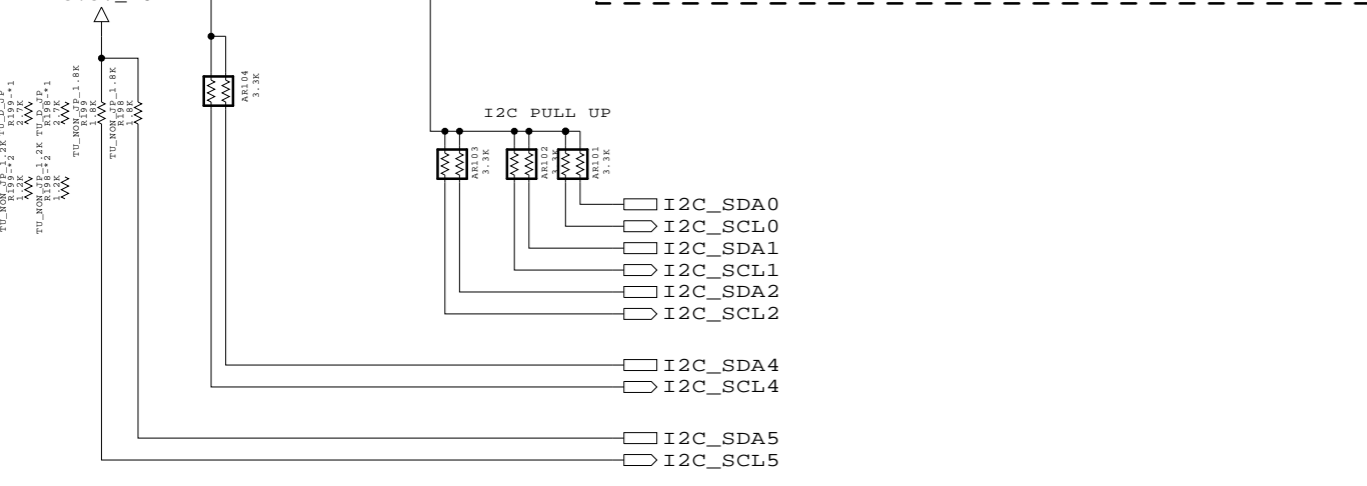
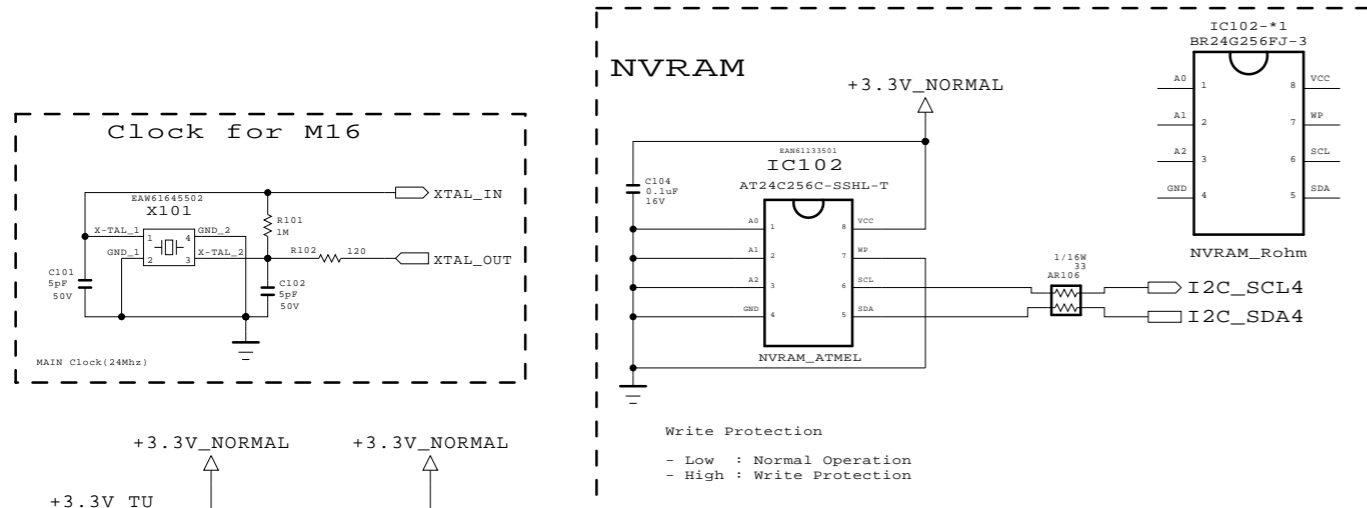

THE Δ SYMBOL MARK OF THIS SCHEMATIC DIAGRAM INCORPORATES SPECIAL FEATURES IMPORTANT FOR PROTECTION FROM X-RADIATION, FIRE AND ELECTRICAL SHOCK HAZARDS, WHEN SERVICING IF IS ESSENTIAL THAT ONLY MANUFACTURERS SPECIFIED PARTS BE USED FOR THE CRITICAL COMPONENTS IN THE Δ SYMBOL MARK OF THE SCHEMATIC.

SECRET
 LGElectronics



MODEL	M16	DATE	2015.02.24
BLOCK	M16 Symbol A	SHEET	1 / 26



BIT 0/1 : AREA OPTION				BIT 2/3 : TUNER OPTION				BIT 4/5/6 : BACK-END OPTION									
BIT [0/1]	DVB	ATSC	JP	BIT(2/3)	EU/CIS	AJSA	TW/COL	CN/RK	KR	N.America	BR	JP	BIT(4/5/6)	DISPLAY TYPE	FHD/UND	TYPE	COMMENT
0 / 0	TAIWAN/COLOR	N/AMERICA		0/0	T2/C/S2 PIP EXT_ATV	T EXT_ATV	T2/C PIP EXT_ATV	EXT_ATV	ATSC+T2 INT_ATV	INT_ATV	ISDB PIP EXT_ATV	Default	0 / 0 / 0	LCD	UND	VBY1	M16+P16 / M16 VX1
0 / 1	CHINA/HONGKONG	KOREA	JAPAN	0/1	T2/C/S2 INT_ATV	T2/C/S2 INT_ATV	T2 EXT_ATV	INT_ATV	ATSC+T2 INT_ATV	EXT_ATV	ISDB EXT_ATV		0 / 1 / 0	LCD	UND	EPI	M16 EPI
1 / 0	EU/CIS	S/AMERICA		1/0	T2/C/S2 EXT_ATV	T2/C/S2 EXT_ATV	T2 INT_ATV	INT_ATV	ATSC+T2 EXT_ATV		ISDB INT_ATV		0 / 1 / 1	LCD	UND		RESERVED
1 / 1	ASIA/AFRICA	Sri Lanka		1/1	T2 EXT_ATV	T2	T2 INT_ATV	INT_ATV	ATSC+T2 EXT_ATV		ISDB INT_ATV		1 / 0 / 1	OLED	UND	VBY1	RESERVED
													1 / 0 / 0	OLED	FHD	VBY1	RESERVED
													1 / 1 / 0	OLED	FHD	VBY1	
													1 / 1 / 1	OLED	FHD	VBY1	RESERVED

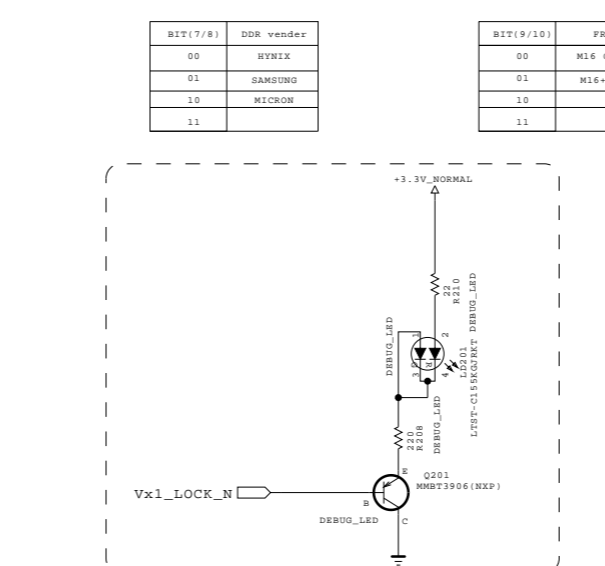
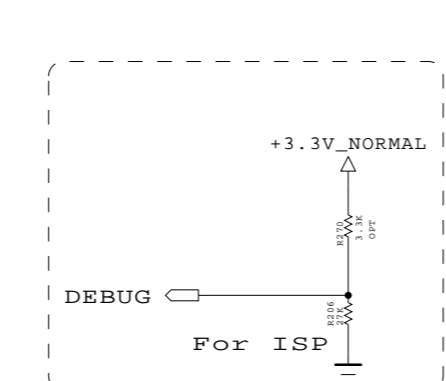
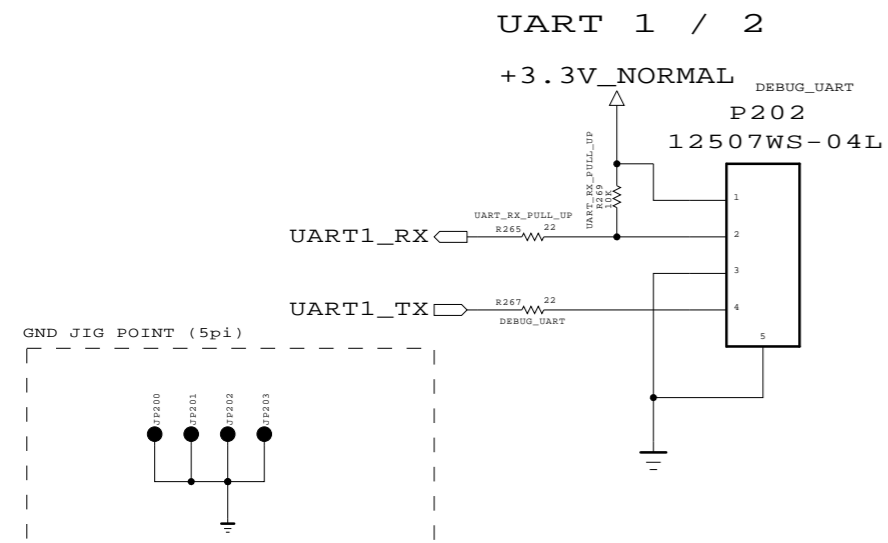

THE Δ SYMBOL MARK OF THIS SCHEMATIC DIAGRAM INCORPORATES SPECIAL FEATURES IMPORTANT FOR PROTECTION FROM X-RADIATION. FIRE AND ELECTRICAL SHOCK HAZARDS, WHEN SERVICING IF IS ESSENTIAL THAT ONLY MANUFACTURES SPECIFIED PARTS BE USED FOR THE CRITICAL COMPONENTS IN THE Δ SYMBOL MARK OF THE SCHEMATIC.

SECRET
LGElectronics



MODEL	M16	DATE	2015.11.23
BLOCK	M16 Symbol B	SHEET	2 / 99

JACK Side SOC Side

AV_CVBS_IN → R301 100 → AV1_CVBS_IN_SOC

TU_CVBS → R303 100 → TU_CVBS_SOC

COMP2_Pb → R307 33 → COMP2_Pb_IN_SOC

COMP2_Y → R308 33 → COMP2_Y_IN_SOC

COMP2_Pr → R309 33 → COMP2_Pr_IN_SOC

COMP2/AV_L_IN → R312 27K → AUAD_L_CH2_IN

COMP2/AV_R_IN → R313 27K → AUAD_R_CH2_IN

Placed as close as possible to IC101

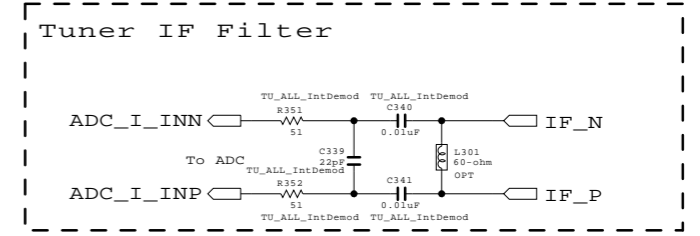
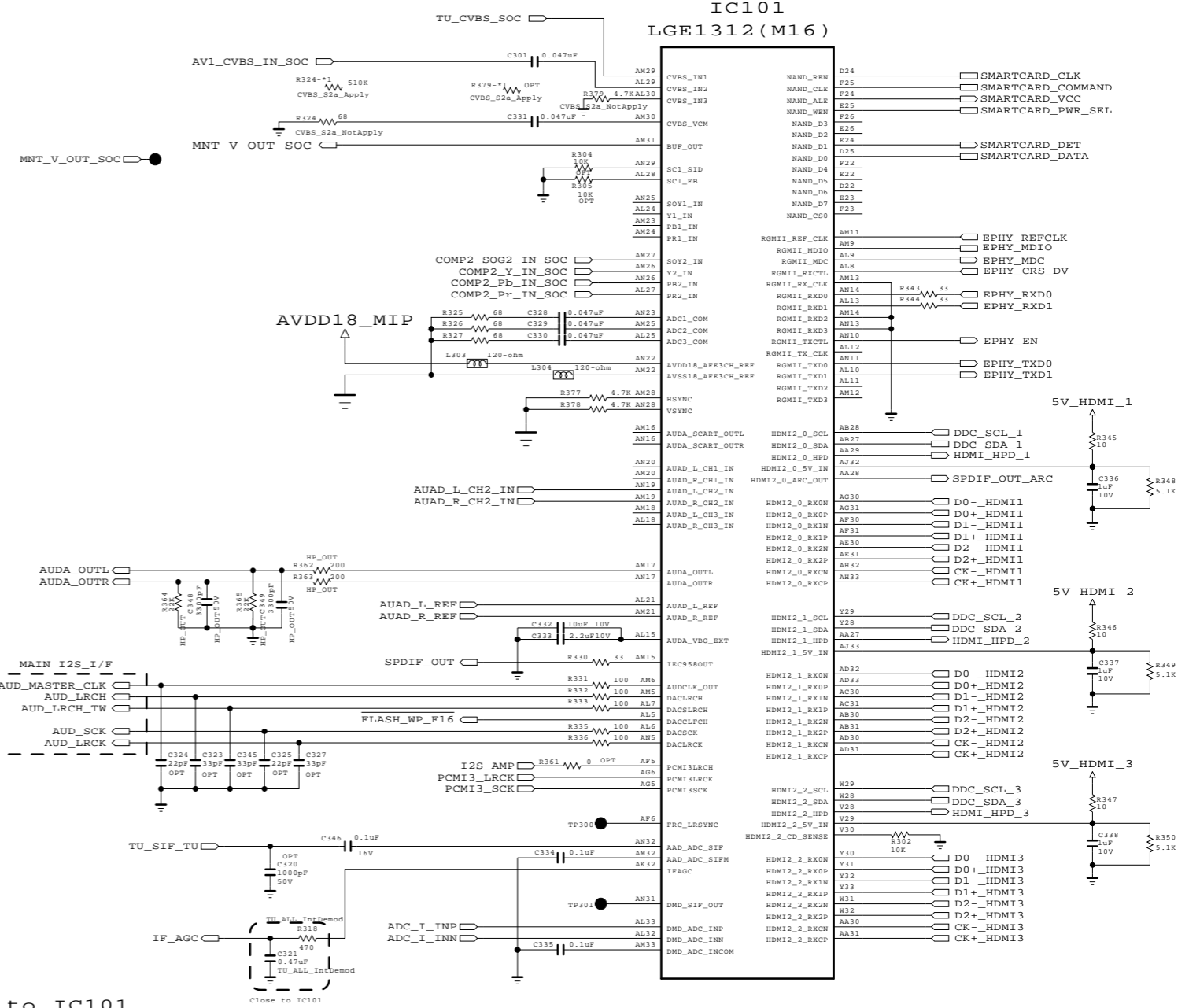
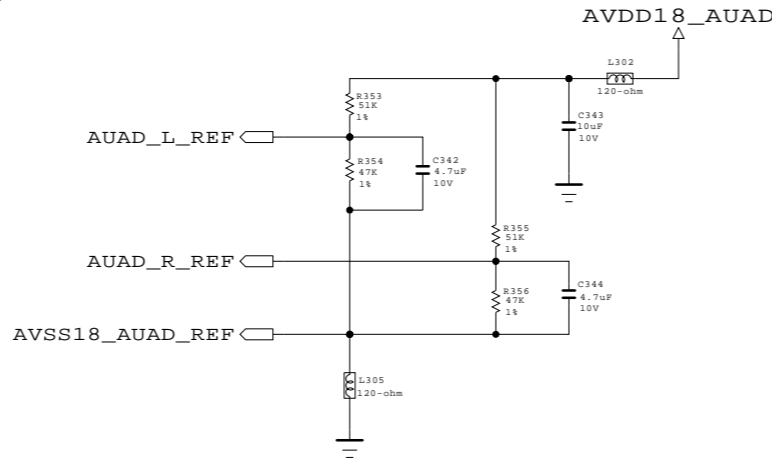

Placed as close as possible to IC101

THE Δ SYMBOL MARK OF THIS SCHEMATIC DIAGRAM INCORPORATES SPECIAL FEATURES IMPORTANT FOR PROTECTION FROM X-RADIATION, FIRE AND ELECTRICAL SHOCK HAZARDS, WHEN SERVICING IF IS ESSENTIAL THAT ONLY MANUFACTURERS SPECIFIED PARTS BE USED FOR THE CRITICAL COMPONENTS IN THE Δ SYMBOL MARK OF THE SCHEMATIC.

SECRET
LGElectronics



MODEL	M16	DATE	2015.02.23
BLOCK	M16 Symbol C	SHEET	3 / 26

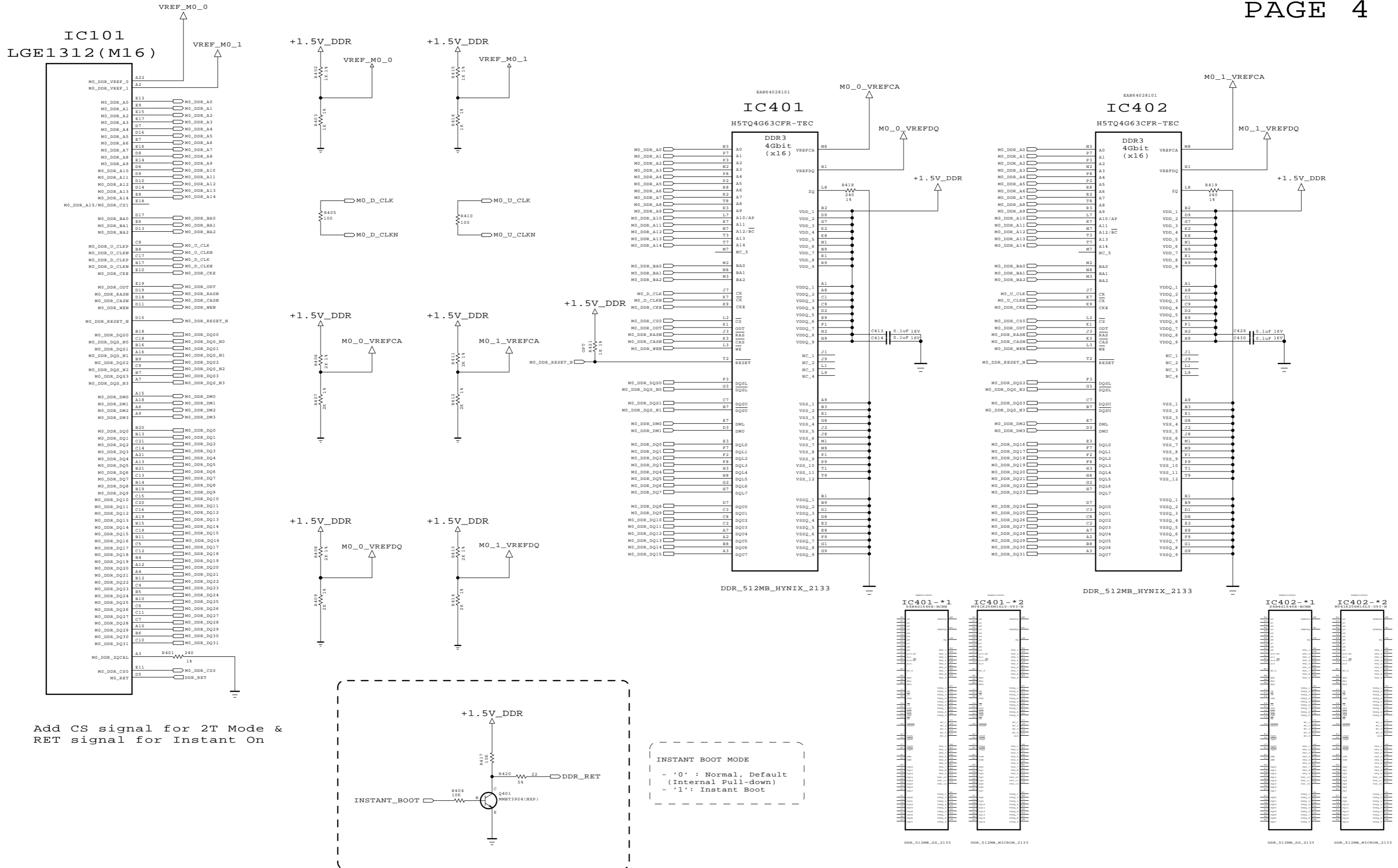

Add CS signal for 2T Mode & RET signal for Instant On

THE Δ SYMBOL MARK OF THIS SCHEMATIC DIAGRAM INCORPORATES SPECIAL FEATURES IMPORTANT FOR PROTECTION FROM X-RADIATION, FIRE AND ELECTRICAL SHOCK HAZARDS, WHEN SERVICING IF IS ESSENTIAL THAT ONLY MANUFACTURERS SPECIFIED PARTS BE USED FOR THE CRITICAL COMPONENTS IN THE Δ SYMBOL MARK OF THE SCHEMATIC.

SECRET
LGElectronics



MODEL	M16	DATE	2015.02.09
BLOCK	M16 DDR3-M0	SHEET	4 / 26

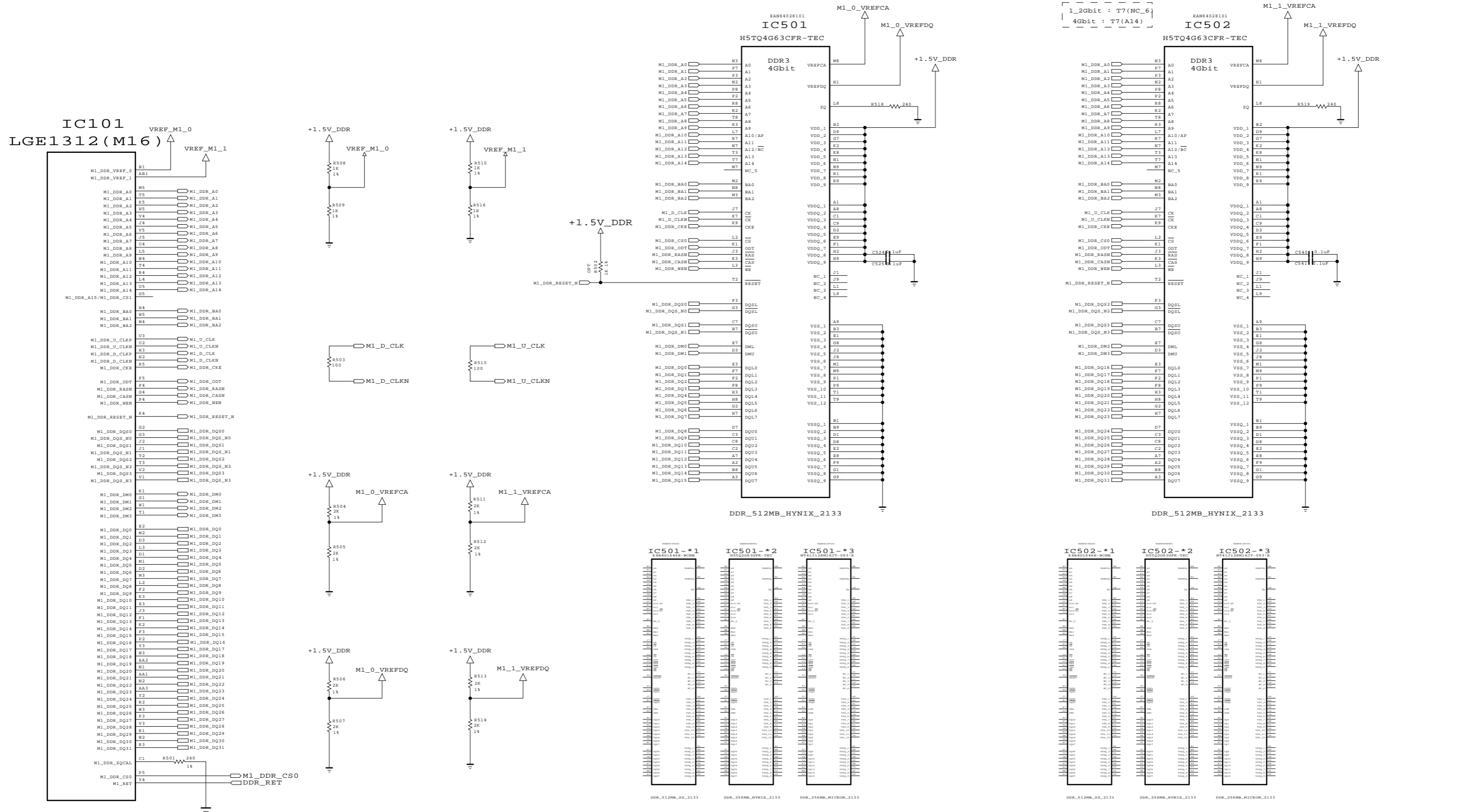

Add CS signal for 2T Mode & RET signal for Instant On

THE Δ SYMBOL MARK OF THIS SCHEMATIC DIAGRAM INCORPORATES SPECIAL FEATURES IMPORTANT FOR PROTECTION FROM X-RADIATION, FIRE AND ELECTRICAL SHOCK HAZARDS, WHEN SERVICING IF IS ESSENTIAL THAT ONLY MANUFACTURERS SPECIFIED PARTS BE USED FOR THE CRITICAL COMPONENTS IN THE Δ SYMBOL MARK OF THE SCHEMATIC.

SECRET
LGElectronics



MODEL	M16	DATE	2016.02.09
BLOCK	M16 DDR3-M1	SHEET	5 / 26

IC101
LGE1312 (M16)

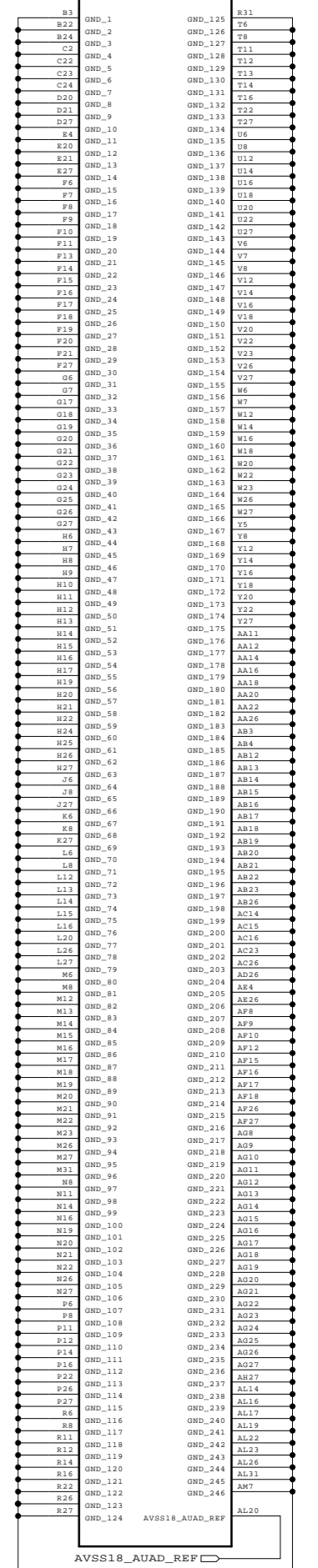
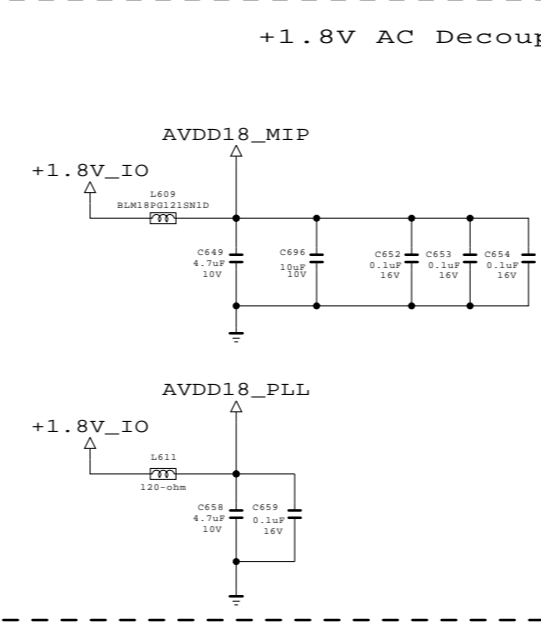
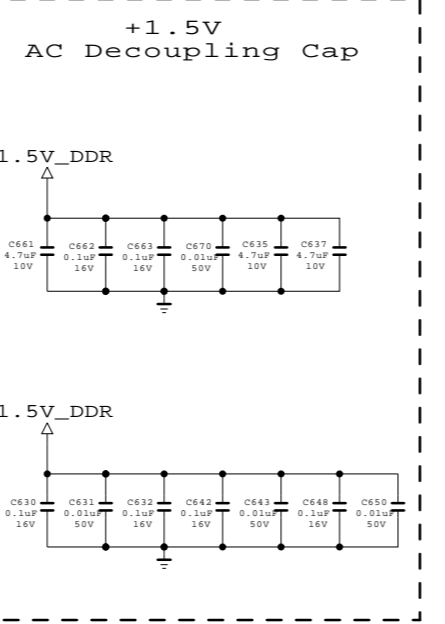
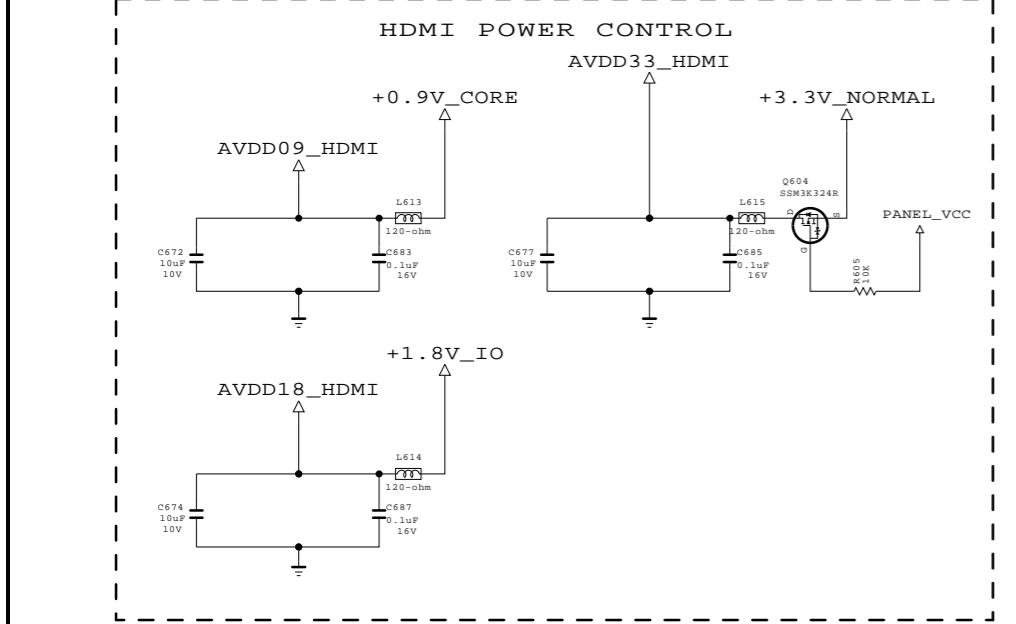
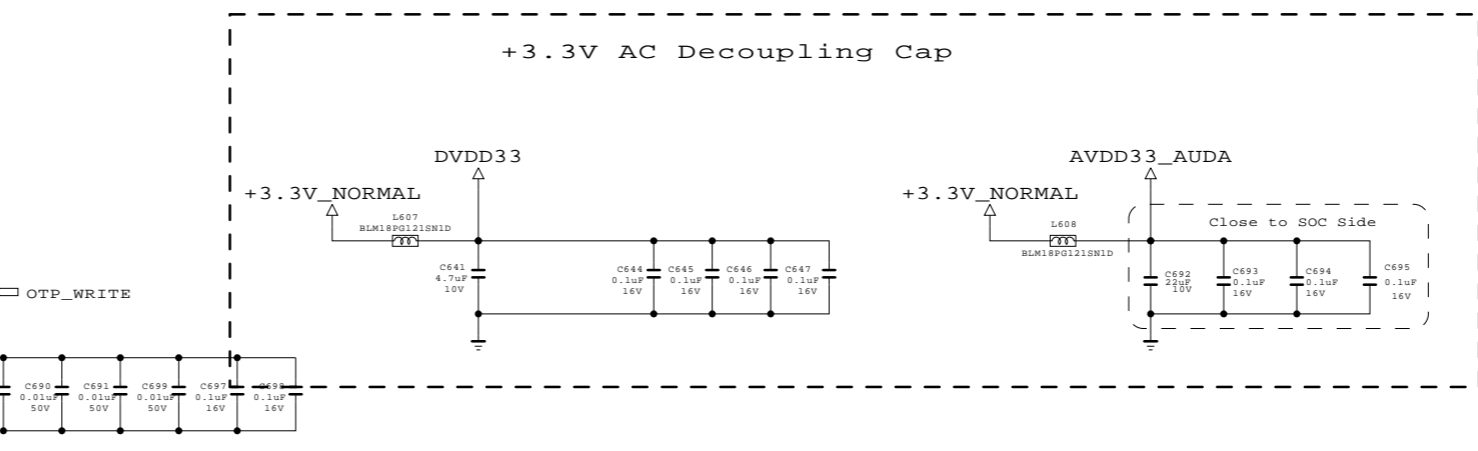
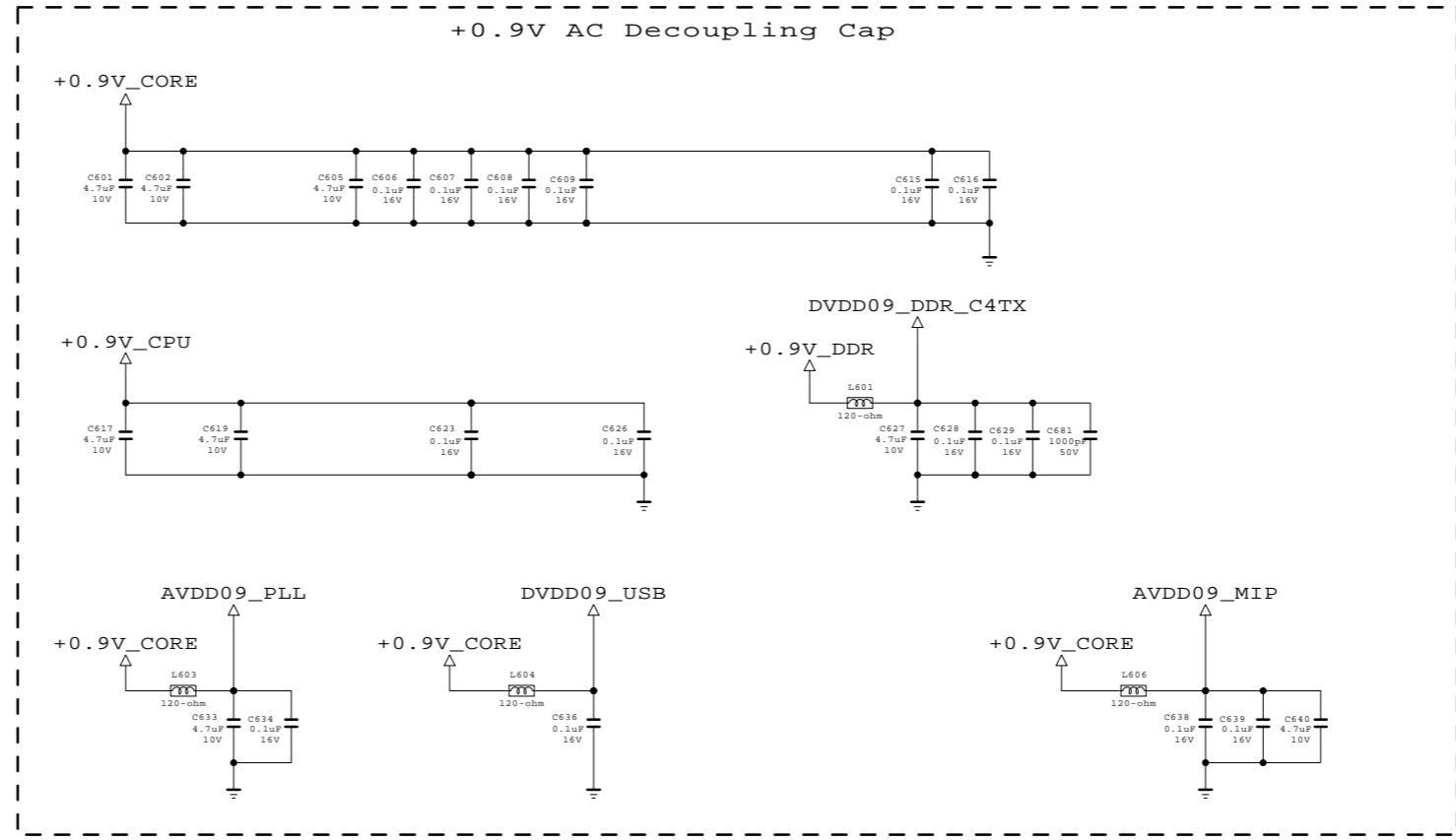
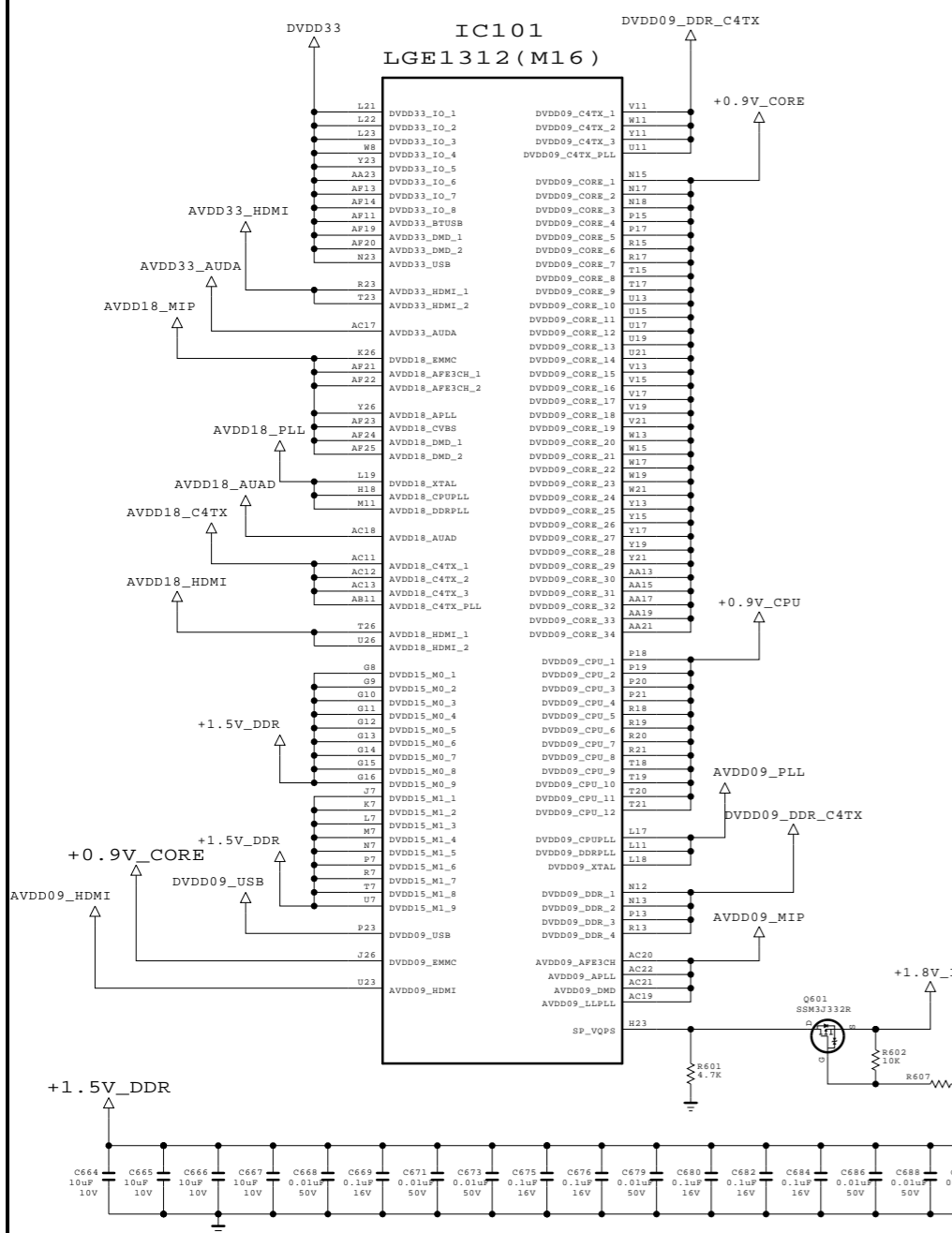

THE Δ SYMBOL MARK OF THIS SCHEMATIC DIAGRAM INCORPORATES SPECIAL FEATURES IMPORTANT FOR PROTECTION FROM X-RADIATION. FIRE AND ELECTRICAL SHOCK HAZARDS, WHEN SERVICING IF IS ESSENTIAL THAT ONLY MANUFACTURES SPECIFIED PARTS BE USED FOR THE CRITICAL COMPONENTS IN THE Δ SYMBOL MARK OF THE SCHEMATIC.

SECRET
LGElectronics



MODEL	M16	DATE	2015.02.16
BLOCK	VCC & GND	SHEET	6 / 27

CI CAM

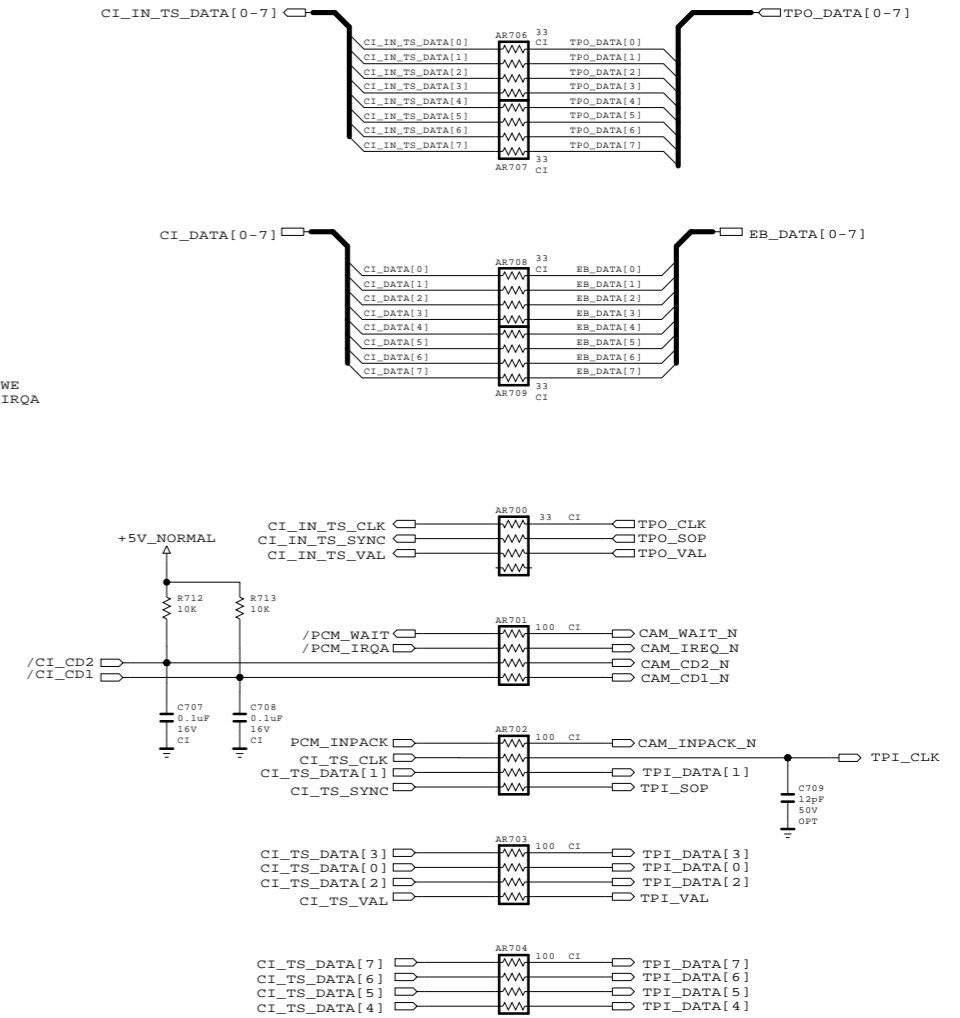
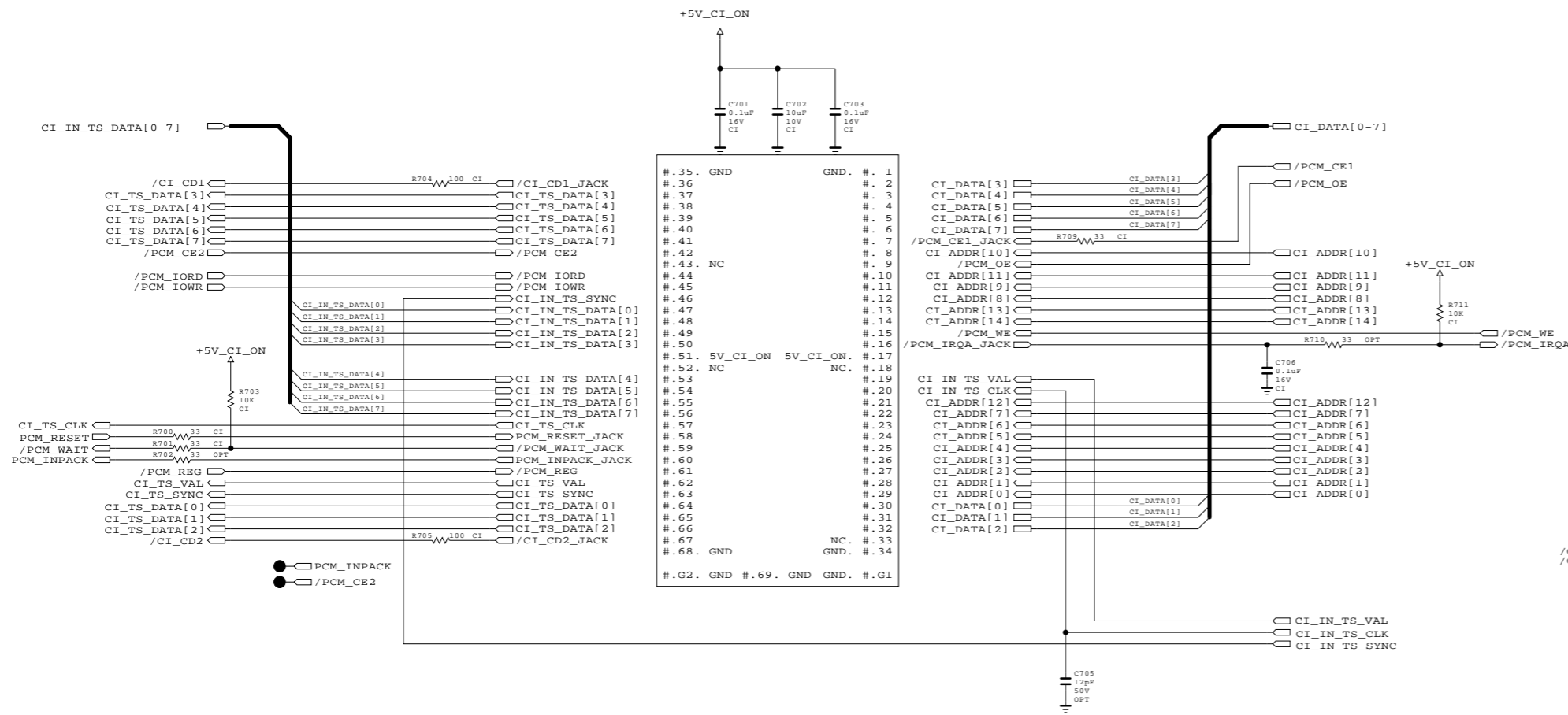
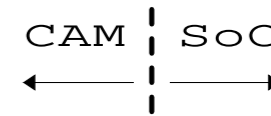

CI POWER ENABLE CONTROL

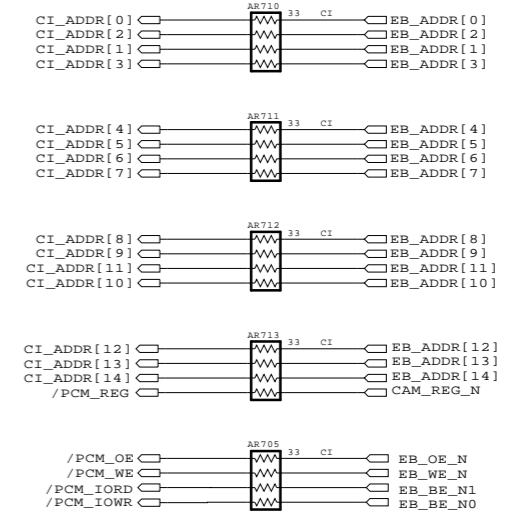
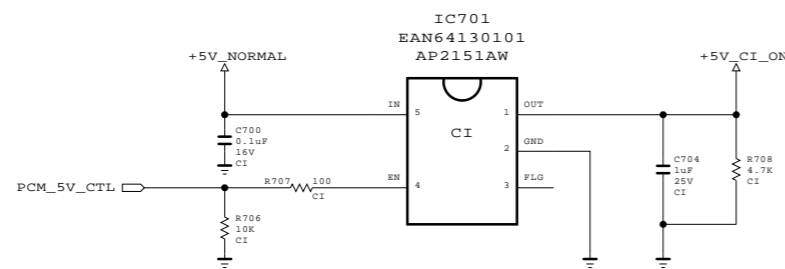

THE Δ SYMBOL MARK OF THIS SCHEMATIC DIAGRAM INCORPORATES SPECIAL FEATURES IMPORTANT FOR PROTECTION FROM X-RADIATION. FIRE AND ELECTRICAL SHOCK HAZARDS, WHEN SERVICING IF IS ESSENTIAL THAT ONLY MANUFACTURERS SPECIFIED PARTS BE USED FOR THE CRITICAL COMPONENTS IN THE Δ SYMBOL MARK OF THE SCHEMATIC.

SECRET
LGElectronics



MODEL	M16	DATE	2015.02.09
BLOCK	CI for DVB	SHEET	7 / 26

CI CAM

CI Slot
 LONG : EAG63217207
 SHORT : EAG63217208

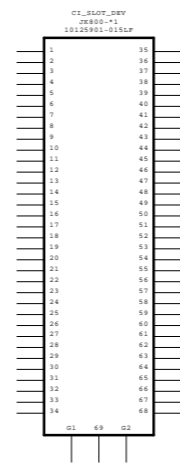
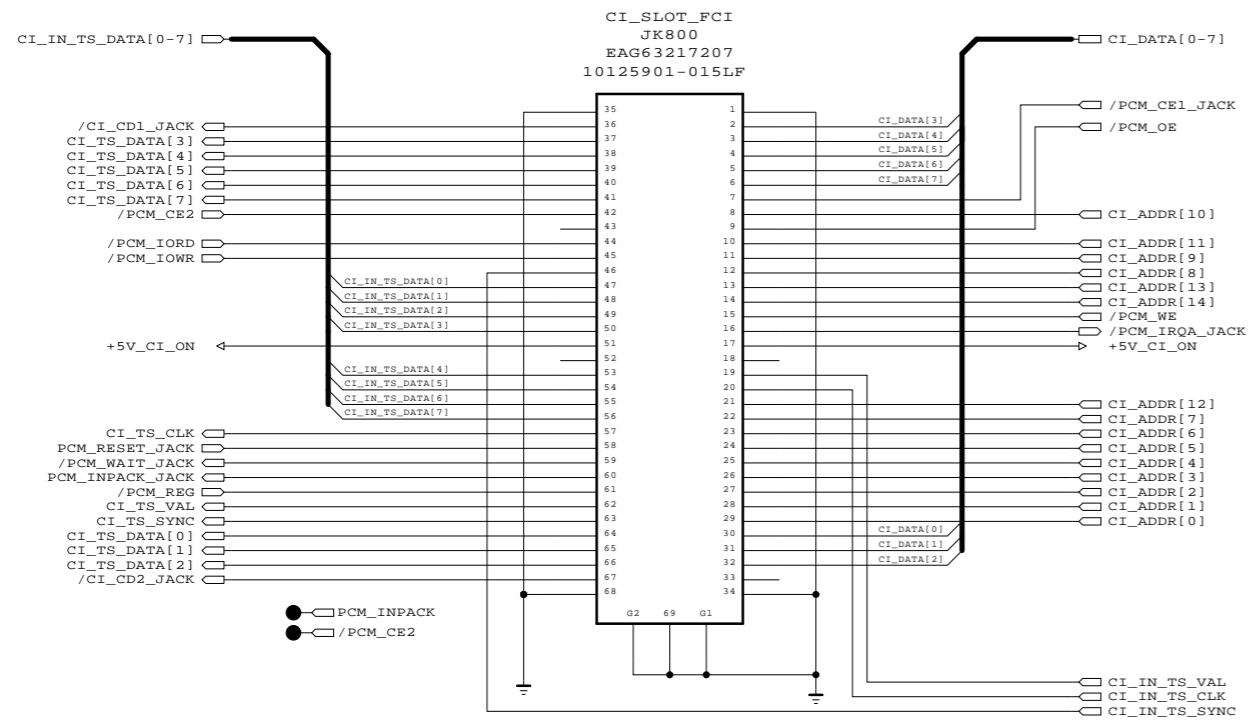

THE Δ SYMBOL MARK OF THIS SCHEMATIC DIAGRAM INCORPORATES SPECIAL FEATURES IMPORTANT FOR PROTECTION FROM X-RADIATION, FIRE AND ELECTRICAL SHOCK HAZARDS, WHEN SERVICING IF IS ESSENTIAL THAT ONLY MANUFACTURERS SPECIFIED PARTS BE USED FOR THE CRITICAL COMPONENTS IN THE Δ SYMBOL MARK OF THE SCHEMATIC.

SECRET
 LGElectronics



MODEL	M16	DATE	2015.02.09
BLOCK	CI for DVB	SHEET	7 / 26

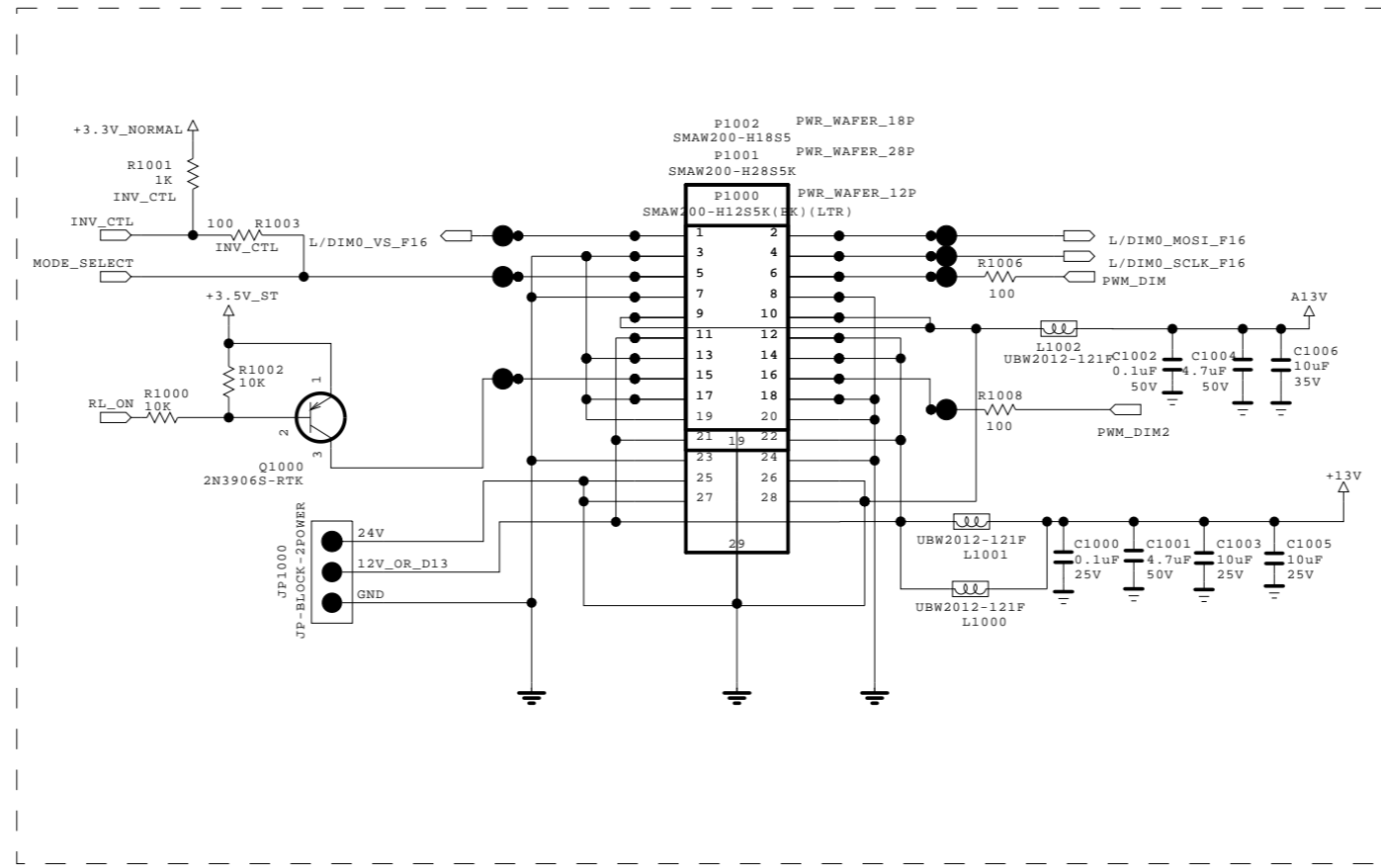

28pin power pin map
12/24V multi power + local dimming

Pin	Signal	Pin	Signal
1	VSYNC	2	SIN
3	GND	4	SCLK
5	DRVON	6	PDIM1
7	GND	8	GND
9	A13	10	A13
11	D13	12	D13
13	GND	14	D13
15	PWR-ON	16	PDIM2
17	GND	18	GND
19	GND	20	GND
21	D13	22	D13
23	GND	24	GND
25	A13	26	A13
27	A13	28	A13

A13 : 12V
D13 : 24V

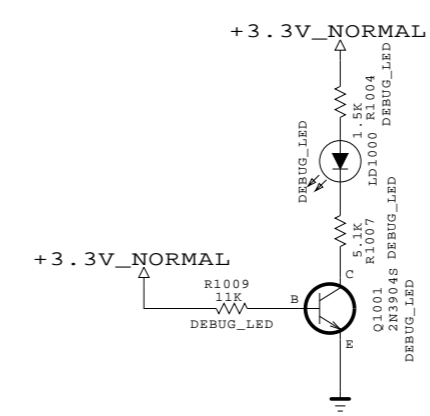

THE SYMBOL MARK OF THIS SCHEMATIC DIAGRAM INCORPORATES SPECIAL FEATURES IMPORTANT FOR PROTECTION FROM X-RADIATION. FIRE AND ELECTRICAL SHOCK HAZARDS, WHEN SERVICING IF IS ESSENTIAL THAT ONLY MANUFACTURES SPECIFIED PARTS BE USED FOR THE CRITICAL COMPONENTS IN THE SYMBOL MARK OF THE SCHEMATIC.

SECRET
LGElectronics



MODEL	Power Wafer (UH80)	DATE	15/06/13
BLOCK		SHEET	/

PANEL_POWER For High Current ($I_{max} = 12A$)

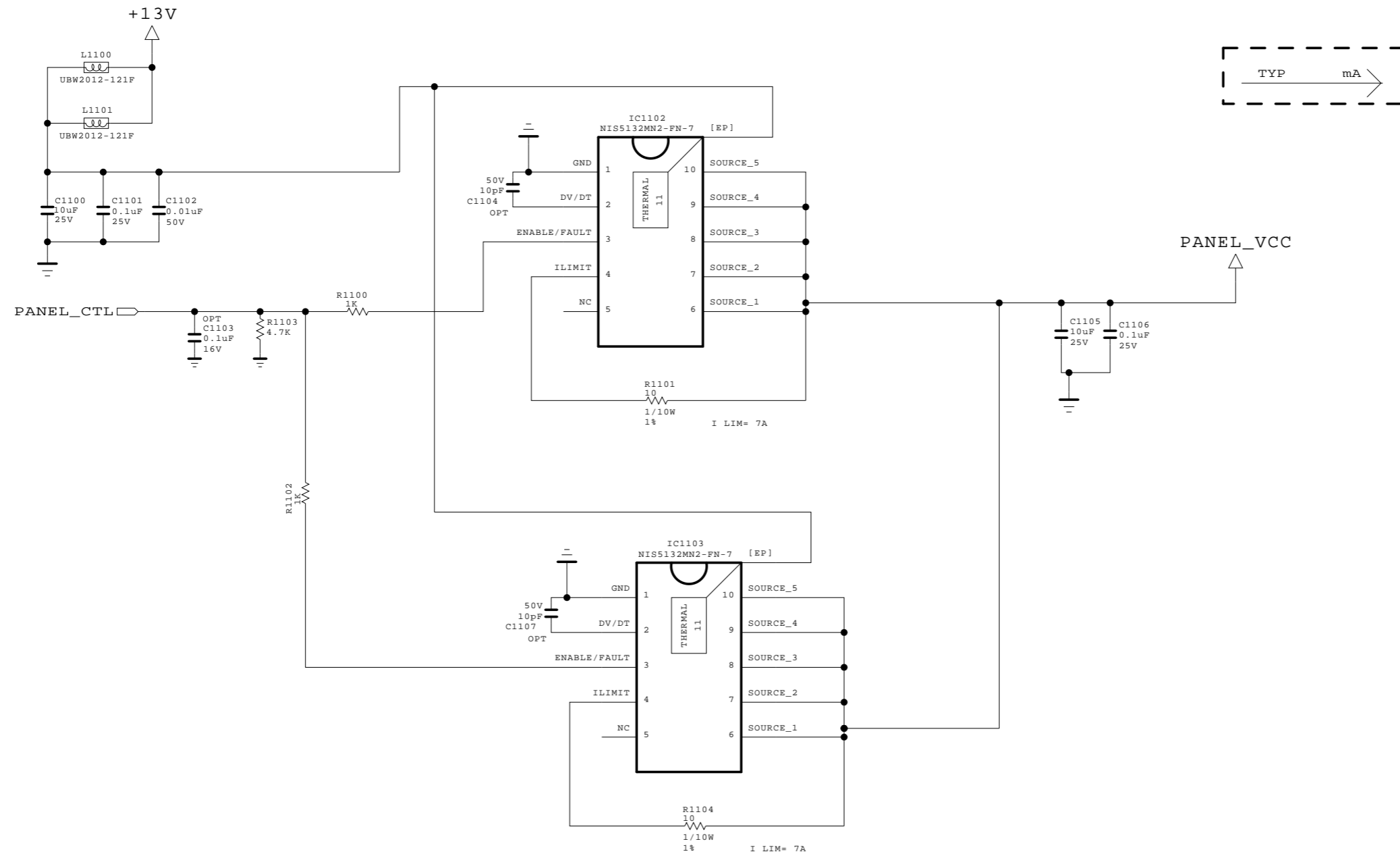

THE SYMBOL MARK OF THIS SCHEMATIC DIAGRAM INCORPORATES SPECIAL FEATURES IMPORTANT FOR PROTECTION FROM X-RADIATION. FIRE AND ELECTRICAL SHOCK HAZARDS, WHEN SERVICING IF IS ESSENTIAL THAT ONLY MANUFACTURERS SPECIFIED PARTS BE USED FOR THE CRITICAL COMPONENTS IN THE SYMBOL MARK OF THE SCHEMATIC.

SECRET
LGElectronics



MODEL	Panel Power	DATE	15/06/13
BLOCK		SHEET	/

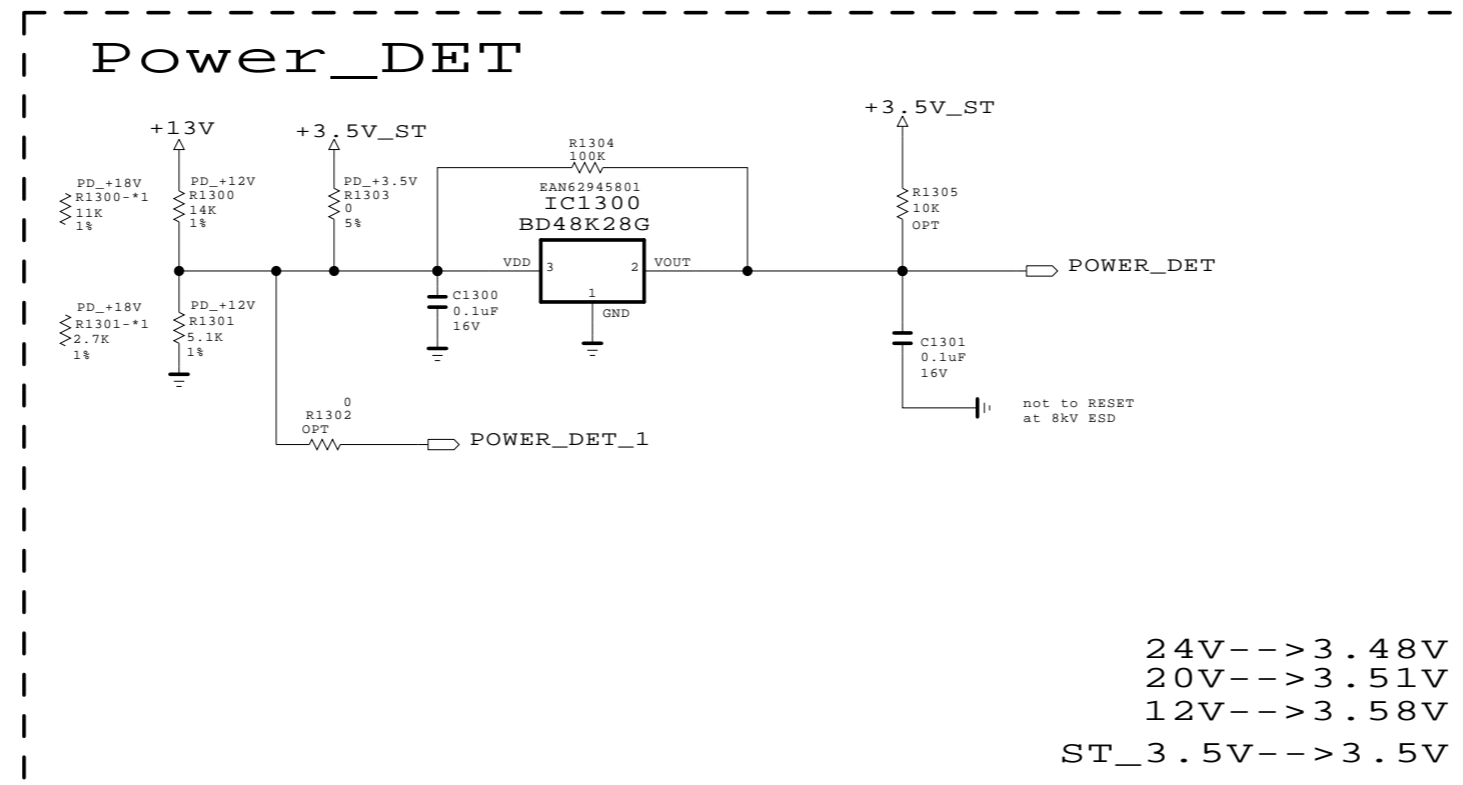

THE SYMBOL MARK OF THIS SCHEMATIC DIAGRAM INCORPORATES SPECIAL FEATURES IMPORTANT FOR PROTECTION FROM X-RADIATION. FIRE AND ELECTRICAL SHOCK HAZARDS, WHEN SERVICING IF IS ESSENTIAL THAT ONLY MANUFACTURERS SPECIFIED PARTS BE USED FOR THE CRITICAL COMPONENTS IN THE SYMBOL MARK OF THE SCHEMATIC.

SECRET
LGElectronics



MODEL	Power det	DATE	15/06/13
BLOCK		SHEET	/

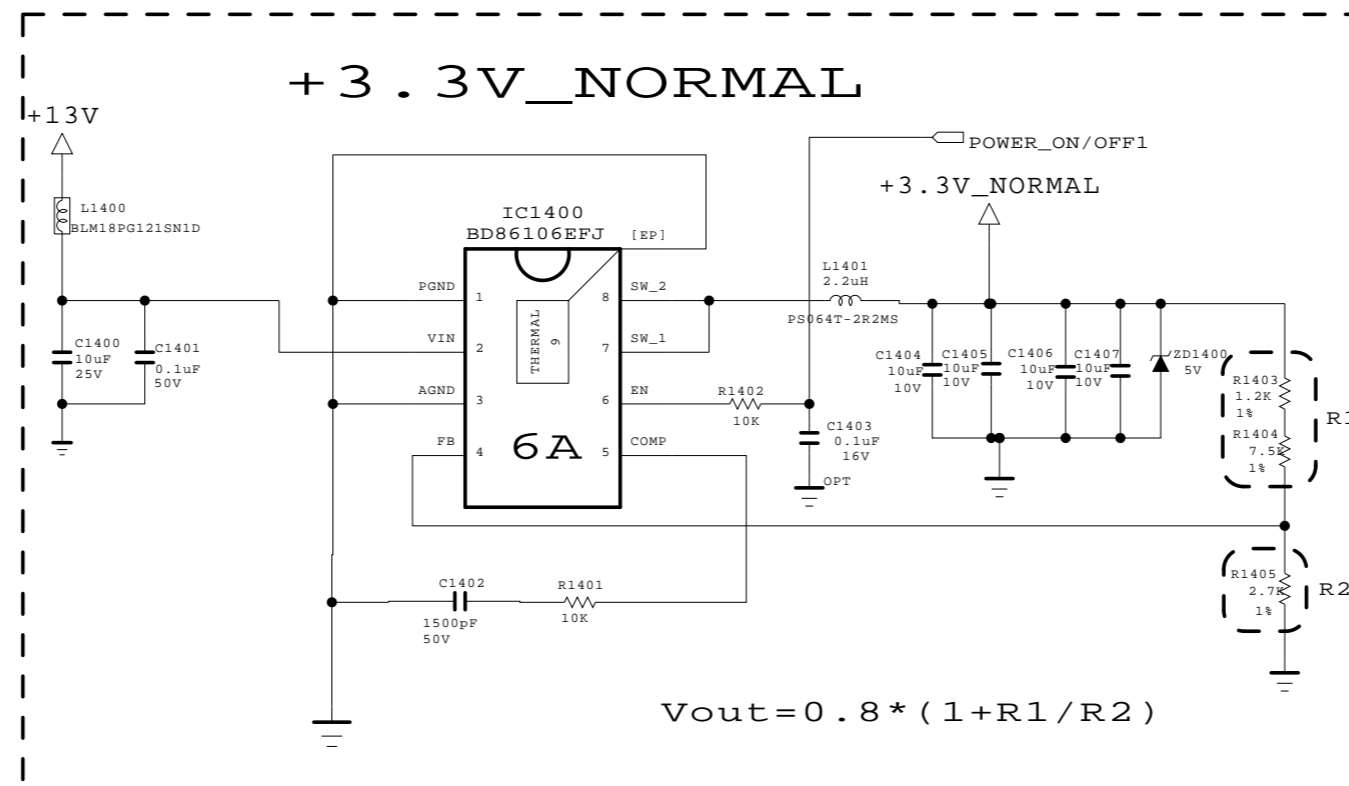

THE SYMBOL MARK OF THIS SCHEMATIC DIAGRAM INCORPORATES SPECIAL FEATURES IMPORTANT FOR PROTECTION FROM X-RADIATION. FIRE AND ELECTRICAL SHOCK HAZARDS, WHEN SERVICING IF IS ESSENTIAL THAT ONLY MANUFACTURES SPECIFIED PARTS BE USED FOR THE CRITICAL COMPONENTS IN THE SYMBOL MARK OF THE SCHEMATIC.

SECRET
LGElectronics



MODEL		DATE	2015.06.02
BLOCK		SHEET	/

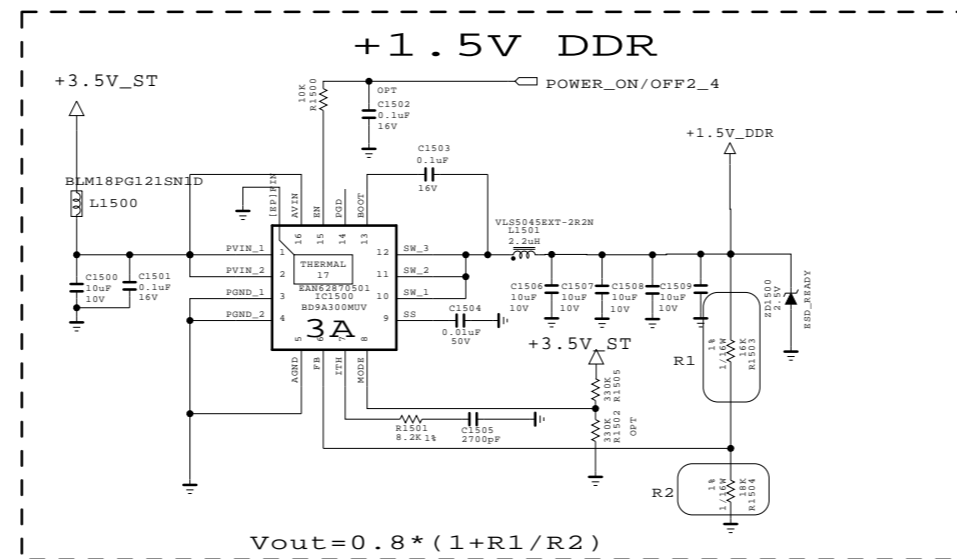



THE Δ SYMBOL MARK OF THIS SCHEMATIC DIAGRAM INCORPORATES SPECIAL FEATURES IMPORTANT FOR PROTECTION FROM X-RADIATION, FIRE AND ELECTRICAL SHOCK HAZARDS, WHEN SERVICING IT IS ESSENTIAL THAT ONLY MANUFACTURERS SPECIFIED PARTS BE USED FOR THE CRITICAL COMPONENTS IN THE Δ SYMBOL MARK OF THE SCHEMATIC.

SECRET
LGElectronics

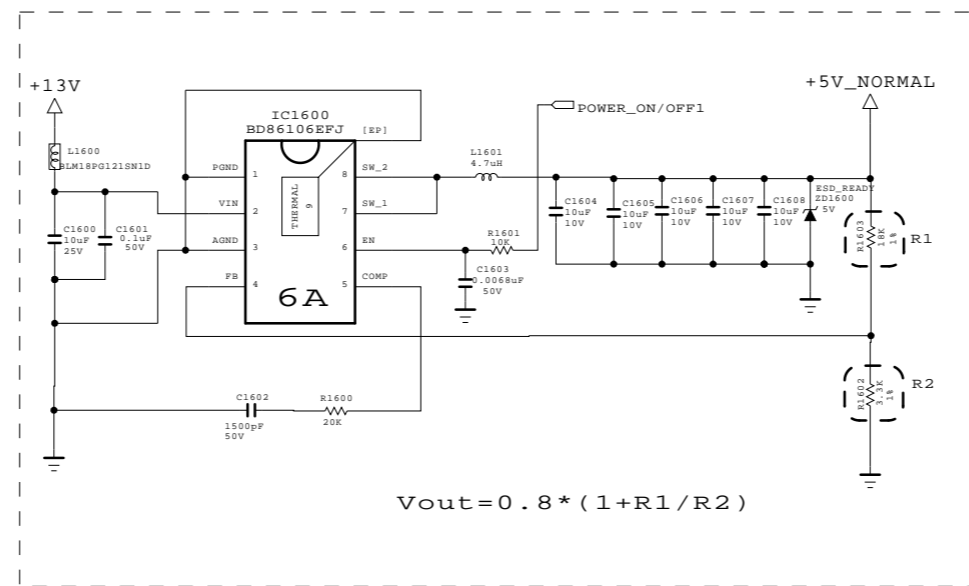

MODEL	M16	DATE	2015.06.03
BLOCK	M16 UHD-mid Power	SHEET	15 / 100



THE  SYMBOL MARK OF THIS SCHEMATIC DIAGRAM INCORPORATES SPECIAL FEATURES IMPORTANT FOR PROTECTION FROM X-RADIATION. FIRE AND ELECTRICAL SHOCK HAZARDS, WHEN SERVICING IF IS ESSENTIAL THAT ONLY MANUFACTURERS SPECIFIED PARTS BE USED FOR THE CRITICAL COMPONENTS IN THE  SYMBOL MARK OF THE SCHEMATIC.

SECRET
LGElectronics



MODEL	M16	DATE	2015.06.03
BLOCK	M16 UHD-mid Power	SHEET	16 / 100

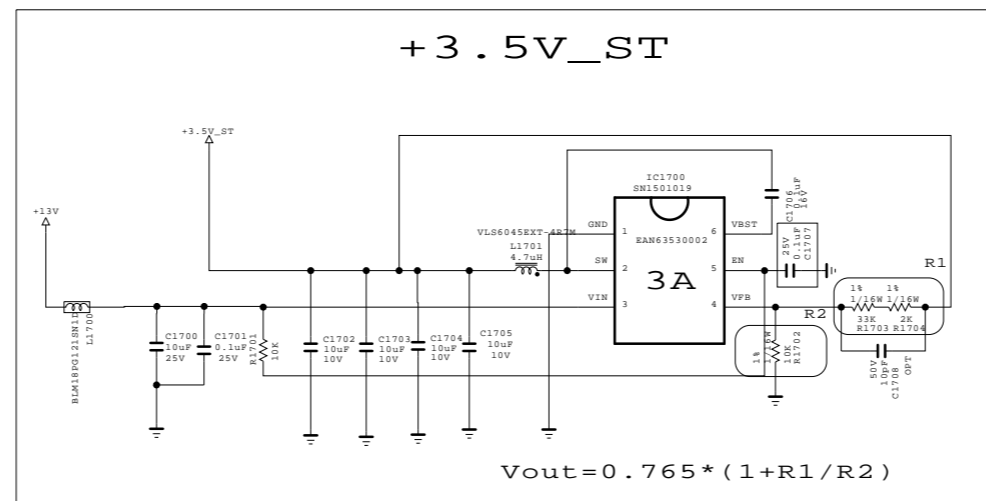

THE SYMBOL MARK OF THIS SCHEMATIC DIAGRAM INCORPORATES SPECIAL FEATURES IMPORTANT FOR PROTECTION FROM X-RADIATION. FIRE AND ELECTRICAL SHOCK HAZARDS, WHEN SERVICING IF IS ESSENTIAL THAT ONLY MANUFACTURES SPECIFIED PARTS BE USED FOR THE CRITICAL COMPONENTS IN THE SYMBOL MARK OF THE SCHEMATIC.

SECRET
LGElectronics



MODEL	M16	DATE	2015.06.03
BLOCK	M16 UHD-mid Power	SHEET	17 / 100

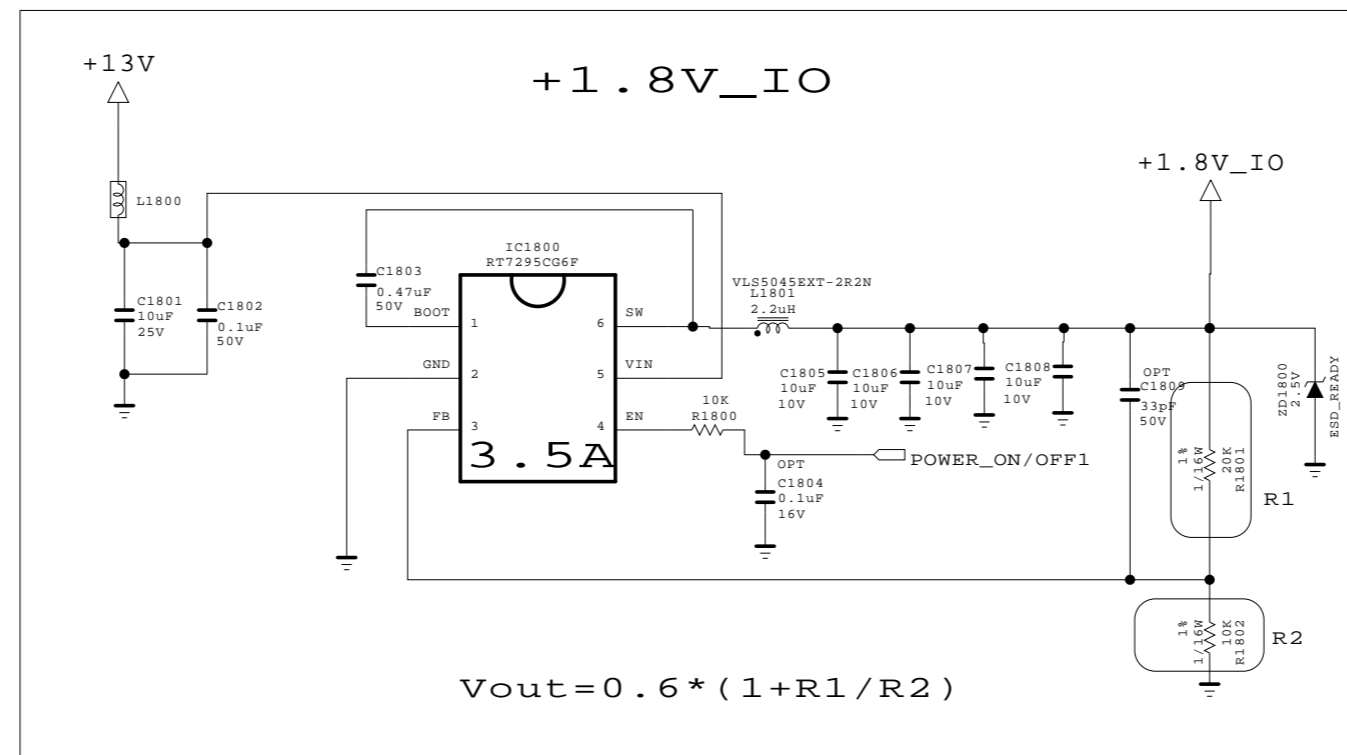

THE SYMBOL MARK OF THIS SCHEMATIC DIAGRAM INCORPORATES SPECIAL FEATURES IMPORTANT FOR PROTECTION FROM X-RADIATION. FIRE AND ELECTRICAL SHOCK HAZARDS, WHEN SERVICING IF IS ESSENTIAL THAT ONLY MANUFACTURERS SPECIFIED PARTS BE USED FOR THE CRITICAL COMPONENTS IN THE SYMBOL MARK OF THE SCHEMATIC.

SECRET
LGElectronics



MODEL		DATE	
BLOCK		SHEET	/

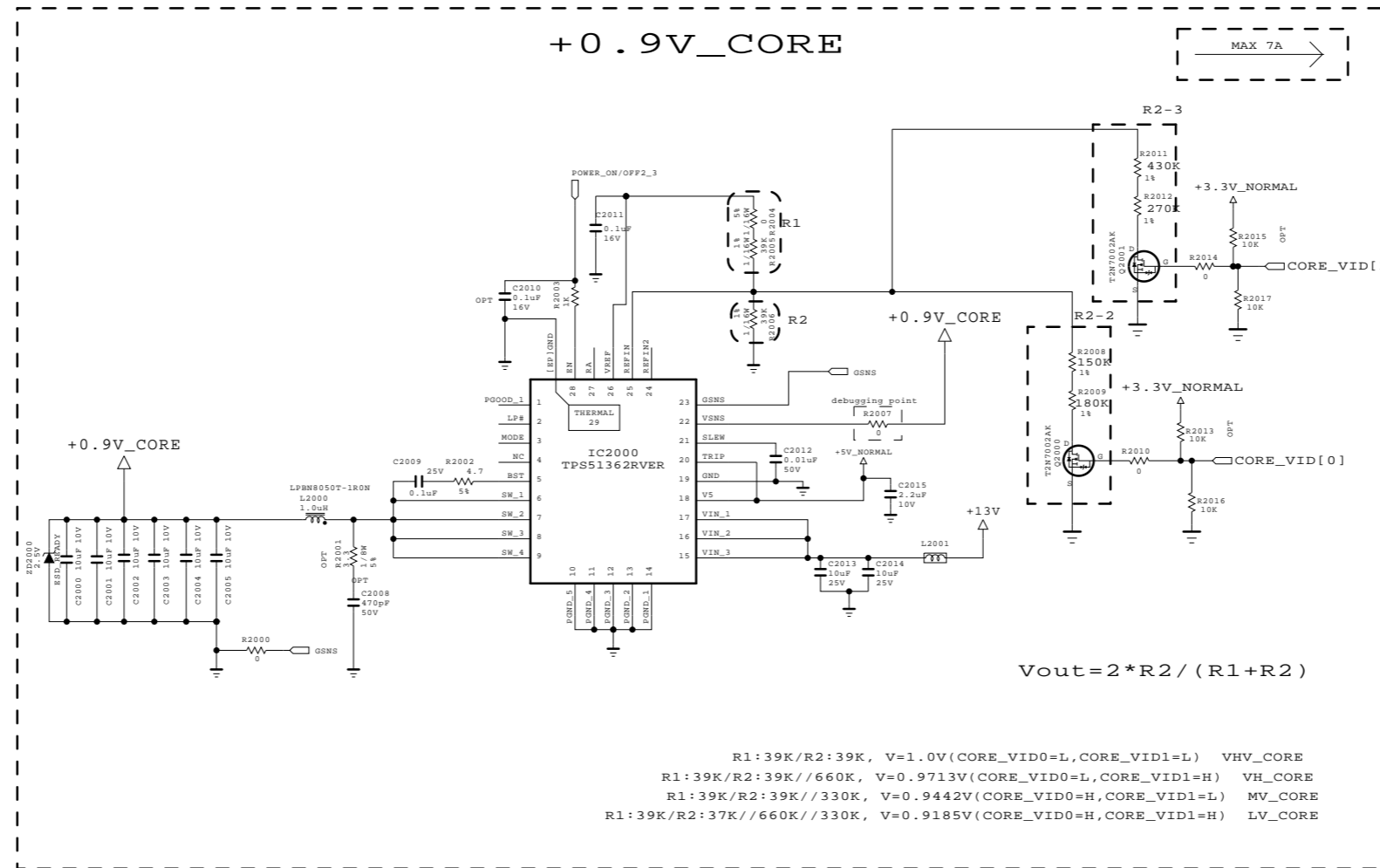

CORE_VID TABLE

CORE_VID0	CORE_VID1	VOUT	R2
L	L	1.0V	39 kohm
L	H	0.9713V	36.94 kohm
H	L	0.9442V	34.87 kohm
H	H	0.9185V	33.22 kohm

THE SYMBOL MARK OF THIS SCHEMATIC DIAGRAM INCORPORATES SPECIAL FEATURES IMPORTANT FOR PROTECTION FROM X-RADIATION. FIRE AND ELECTRICAL SHOCK HAZARDS, WHEN SERVICING IF IS ESSENTIAL THAT ONLY MANUFACTURES SPECIFIED PARTS BE USED FOR THE CRITICAL COMPONENTS IN THE SYMBOL MARK OF THE SCHEMATIC.

SECRET
LGElectronics



MODEL		DATE	15/06/13
BLOCK	M16_0.9V Core	SHEET	19 / 73

020.sht

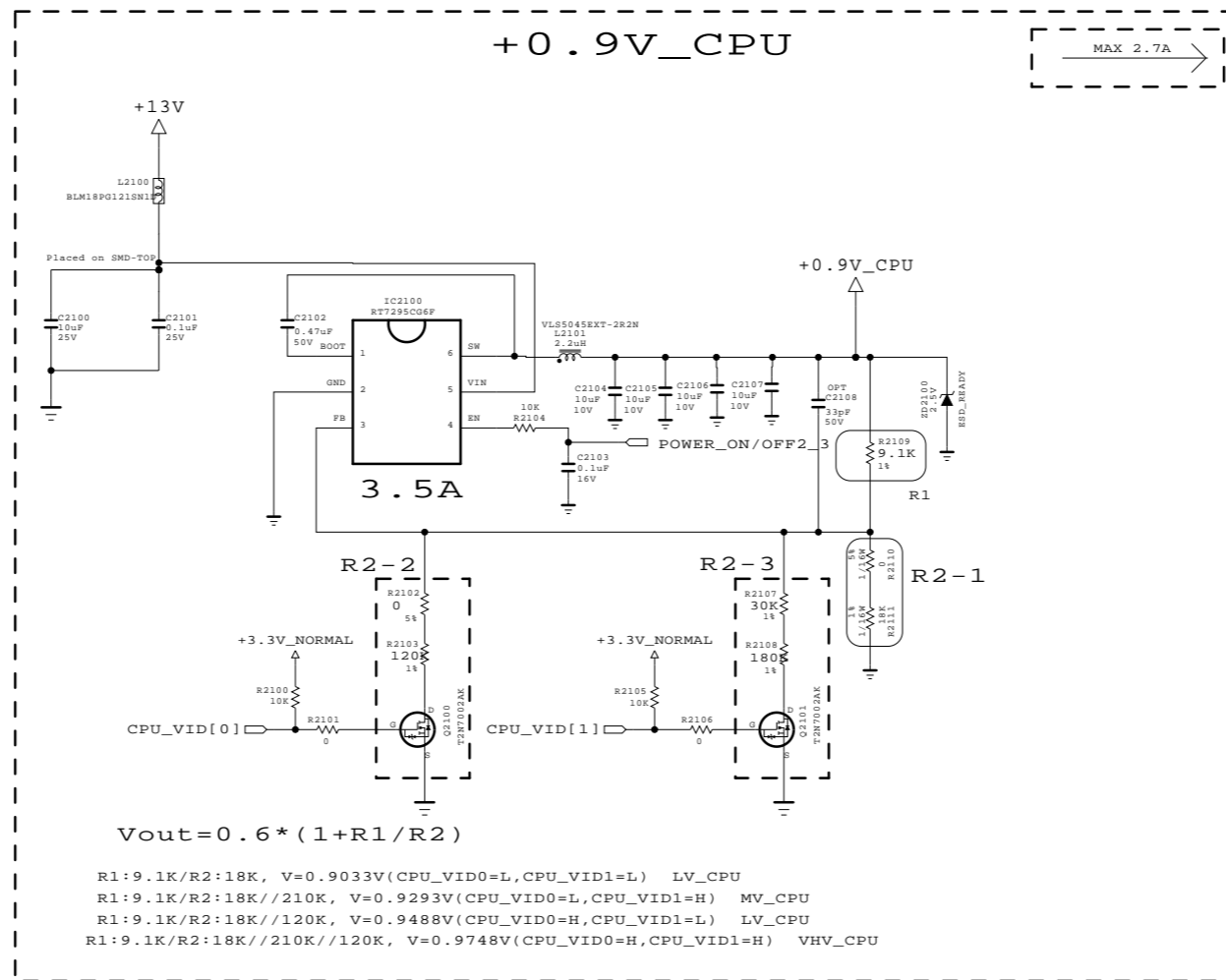

CPU_VID TABLE

CPU_VID0	CPU_VID1	VOUT	R2
L	L	0.9033V	18 kohm
L	H	0.9293V	16.57 kohm
H	L	0.9488V	15.65 kohm
H	H	0.9743V	14.56 kohm

THE SYMBOL MARK OF THIS SCHEMATIC DIAGRAM INCORPORATES SPECIAL FEATURES IMPORTANT FOR PROTECTION FROM X-RADIATION. FIRE AND ELECTRICAL SHOCK HAZARDS, WHEN SERVICING IF IS ESSENTIAL THAT ONLY MANUFACTURES SPECIFIED PARTS BE USED FOR THE CRITICAL COMPONENTS IN THE SYMBOL MARK OF THE SCHEMATIC.



SECRET
LGElectronics

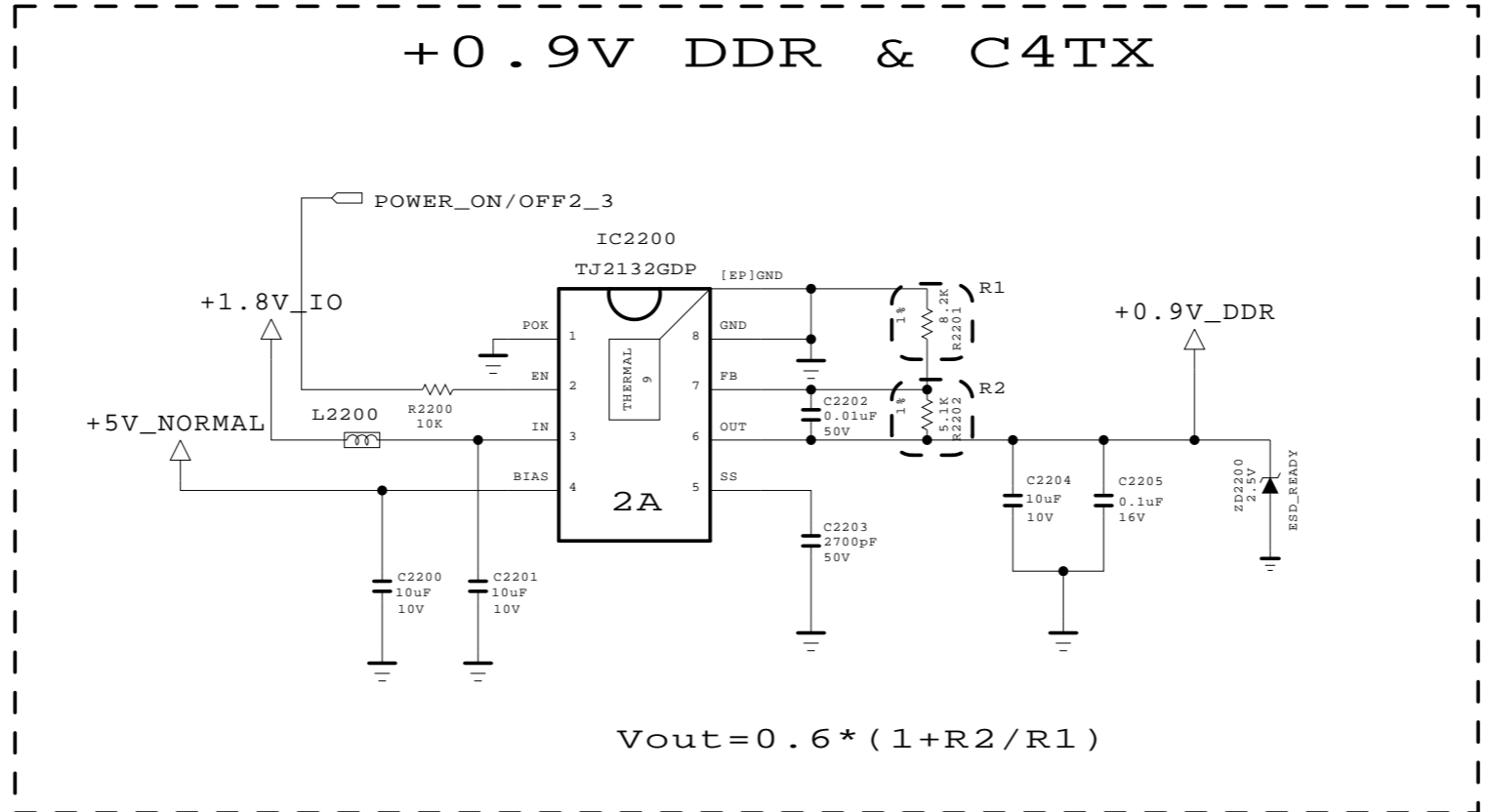

MODEL		DATE	15/06/13
BLOCK	M16_0.9V_CPU	SHEET	20 / 73

+0.9V DDR & C4TX



THE  SYMBOL MARK OF THIS SCHEMATIC DIAGRAM INCORPORATES SPECIAL FEATURES IMPORTANT FOR PROTECTION FROM X-RADIATION. FIRE AND ELECTRICAL SHOCK HAZARDS, WHEN SERVICING IF IS ESSENTIAL THAT ONLY MANUFACTURERS SPECIFIED PARTS BE USED FOR THE CRITICAL COMPONENTS IN THE  SYMBOL MARK OF THE SCHEMATIC.

SECRET
LGElectronics





MODEL		DATE	15/09/24
BLOCK	M16_0.9V DDR & C4TX	SHEET	21 / 73

022.sht

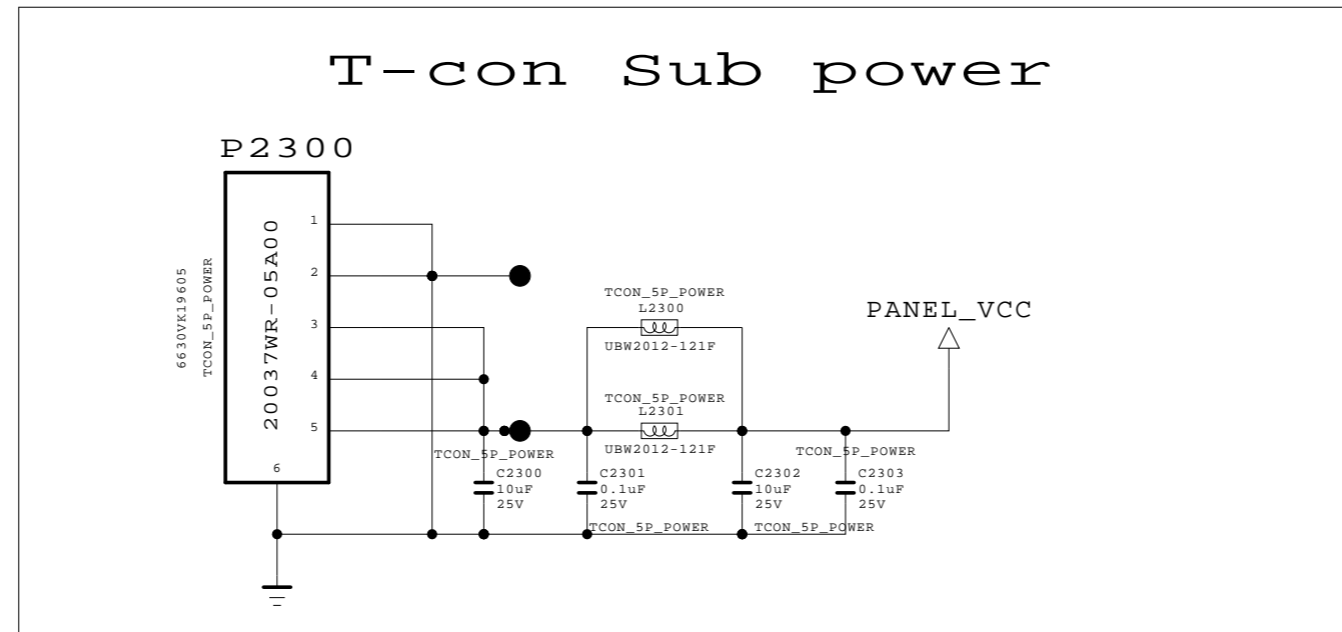
T-con Sub power



THE  SYMBOL MARK OF THIS SCHEMATIC DIAGRAM INCORPORATES SPECIAL FEATURES IMPORTANT FOR PROTECTION FROM X-RADIATION. FIRE AND ELECTRICAL SHOCK HAZARDS, WHEN SERVICING IT IS ESSENTIAL THAT ONLY MANUFACTURERS SPECIFIED PARTS BE USED FOR THE CRITICAL COMPONENTS IN THE  SYMBOL MARK OF THE SCHEMATIC.

SECRET
LGElectronics



MODEL		DATE	15/06/13
BLOCK	T-con power wafer	SHEET	73

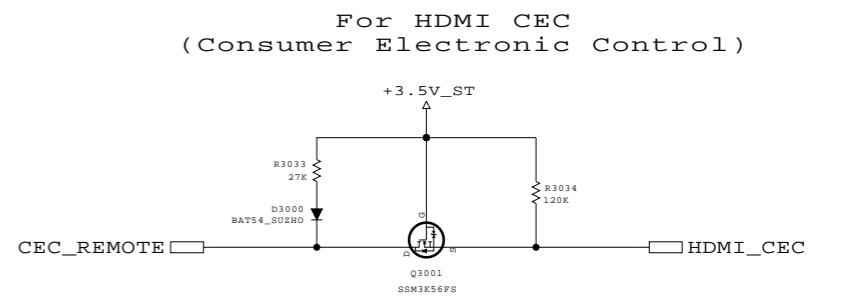
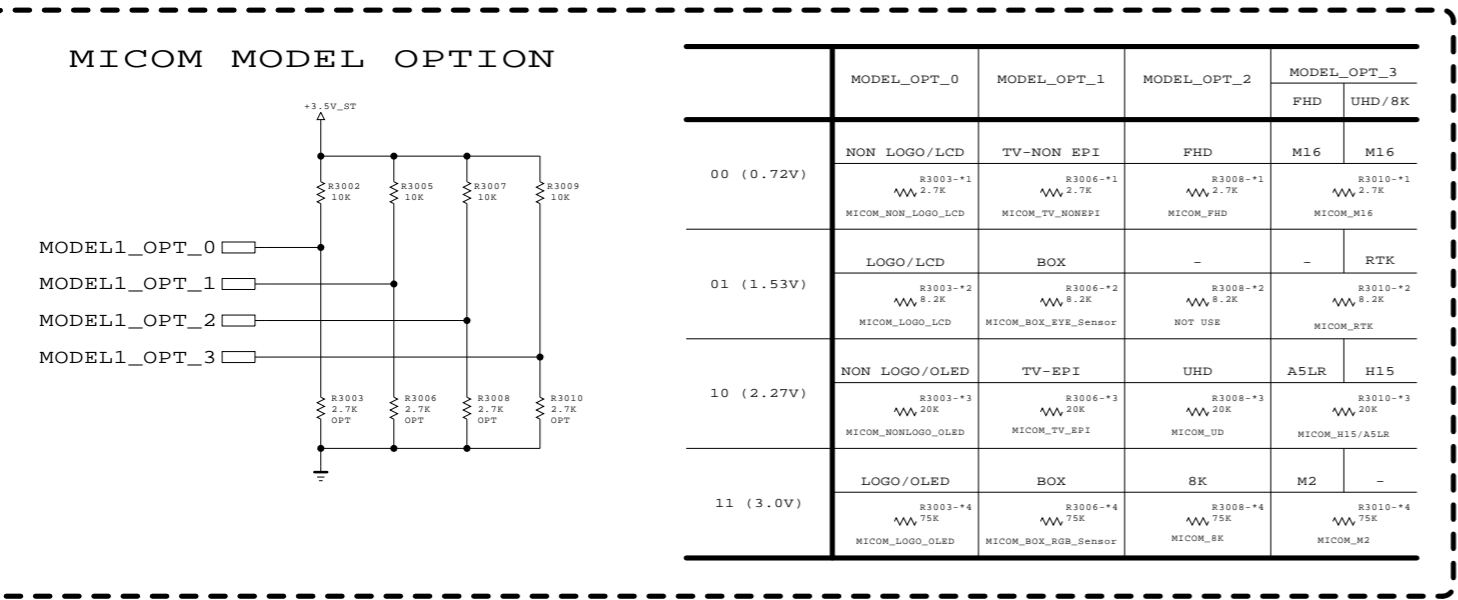
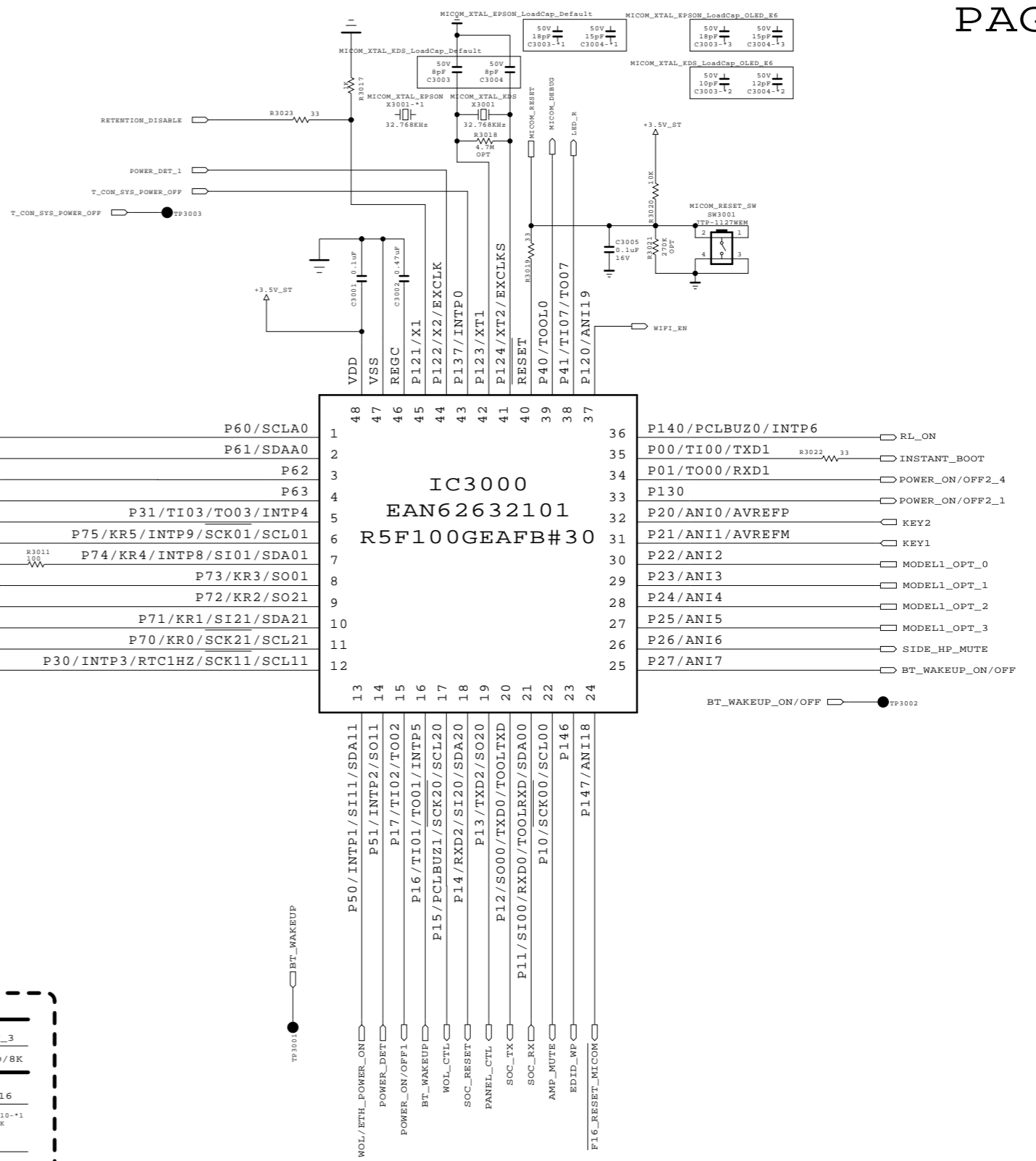
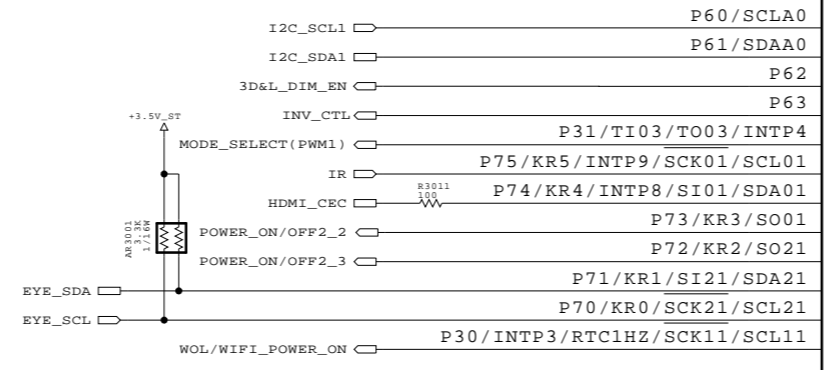
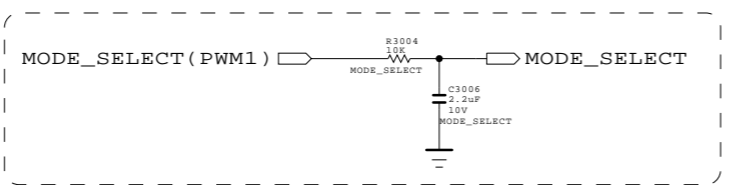
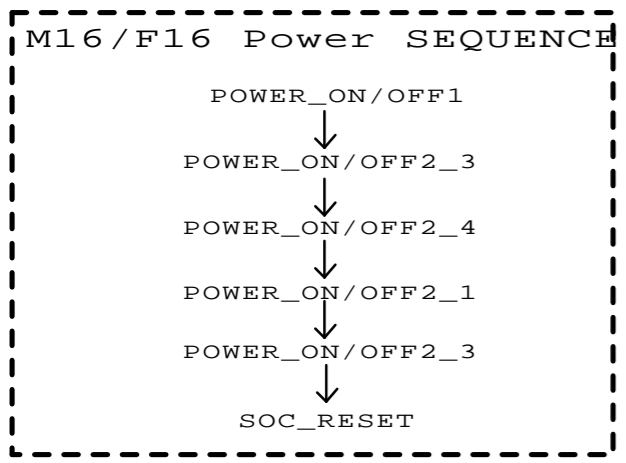
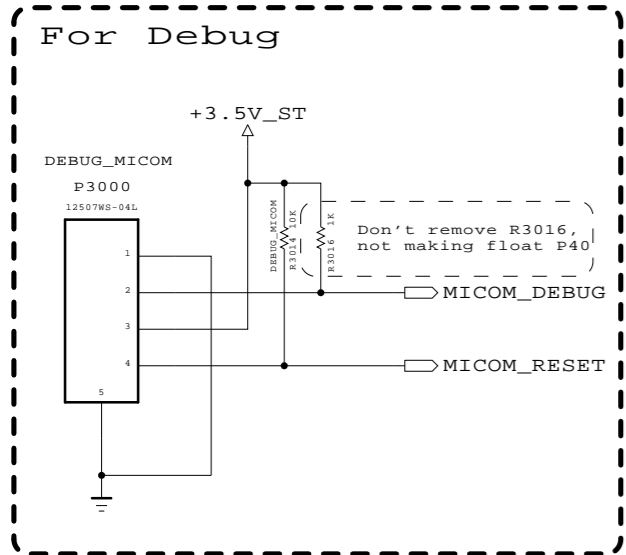

THE Δ SYMBOL MARK OF THIS SCHEMATIC DIAGRAM INCORPORATES SPECIAL FEATURES IMPORTANT FOR PROTECTION FROM X-RADIATION. FIRE AND ELECTRICAL SHOCK HAZARDS, WHEN SERVICING IF IS ESSENTIAL THAT ONLY MANUFACTURERS SPECIFIED PARTS BE USED FOR THE CRITICAL COMPONENTS IN THE Δ SYMBOL MARK OF THE SCHEMATIC.

SECRET
LGElectronics



MODEL	M16	DATE	2015.06.27
BLOCK	MICOM_NEC	SHEET	30 / 99

030.sht

HDMI1 (2.0)

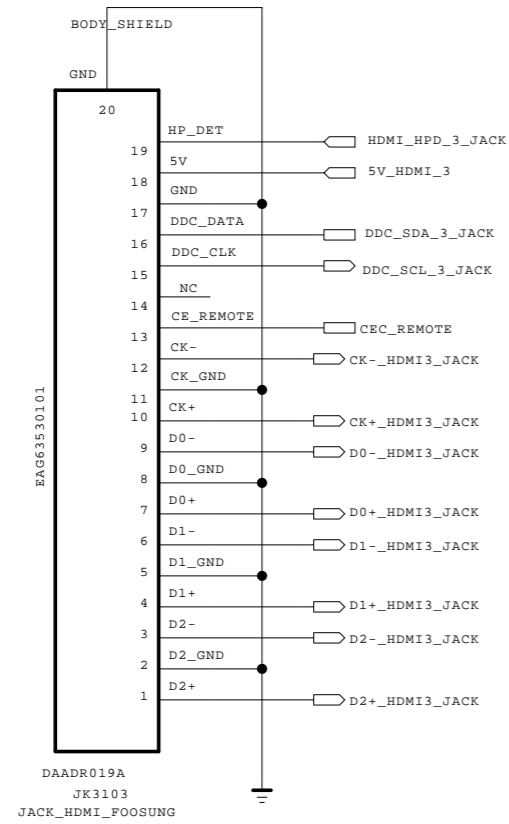

HDMI2 With ARC (2.0)

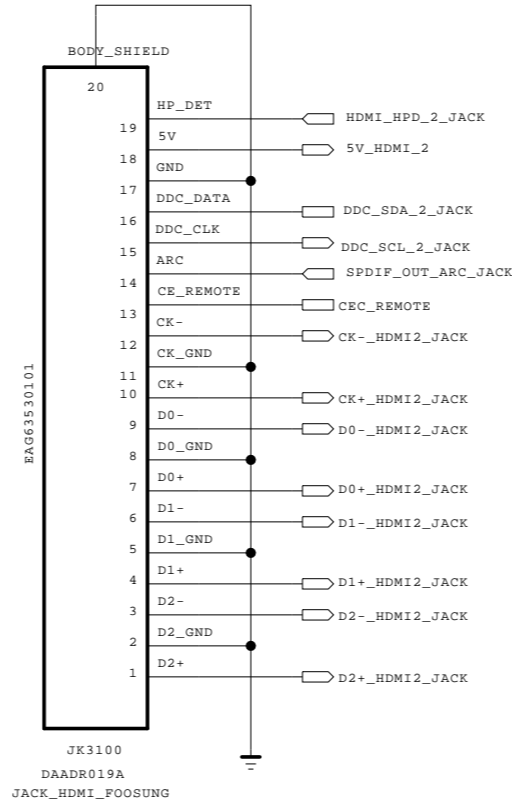

HDMI3 with Ext.EDID (2.0)

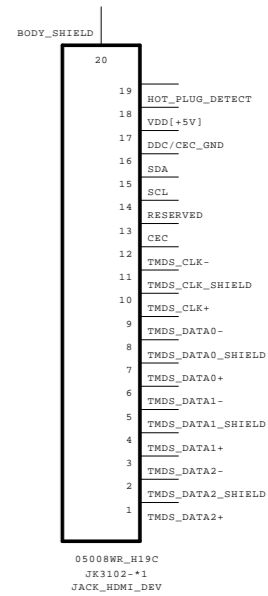
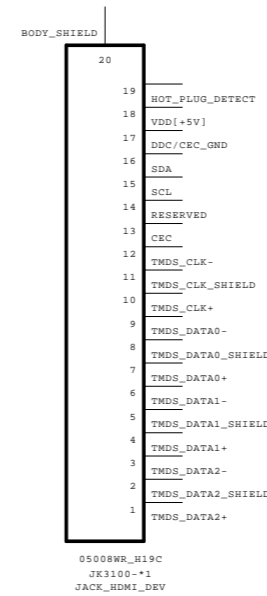
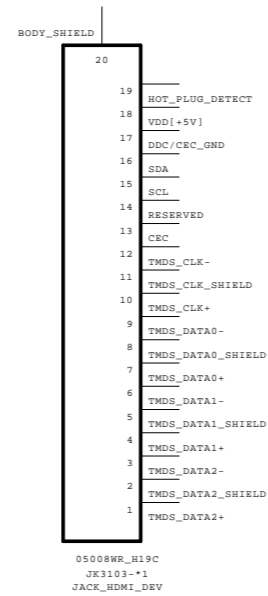
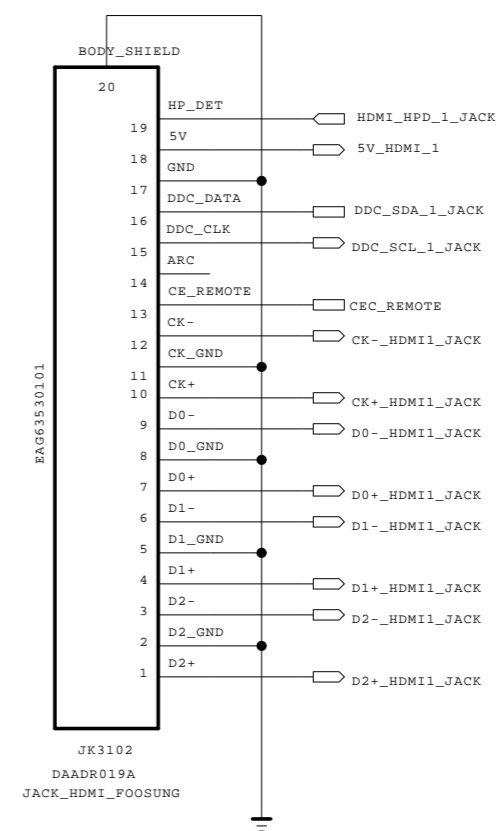

THE SYMBOL MARK OF THIS SCHEMATIC DIAGRAM INCORPORATES SPECIAL FEATURES IMPORTANT FOR PROTECTION FROM X-RADIATION. FIRE AND ELECTRICAL SHOCK HAZARDS, WHEN SERVICING IF IS ESSENTIAL THAT ONLY MANUFACTURES SPECIFIED PARTS BE USED FOR THE CRITICAL COMPONENTS IN THE SYMBOL MARK OF THE SCHEMATIC.

<p>SECRET</p> <p>LG Electronics</p>	<p>LG ELECTRONICS</p>
--	-----------------------

MODEL		DATE	15/06/13
BLOCK	HDMI SYMBOL	SHEET	24 / 73

HDMI1 (2.0)

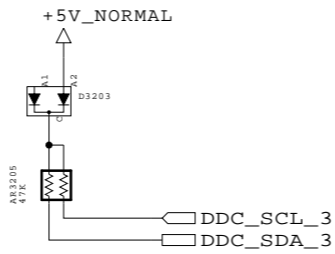
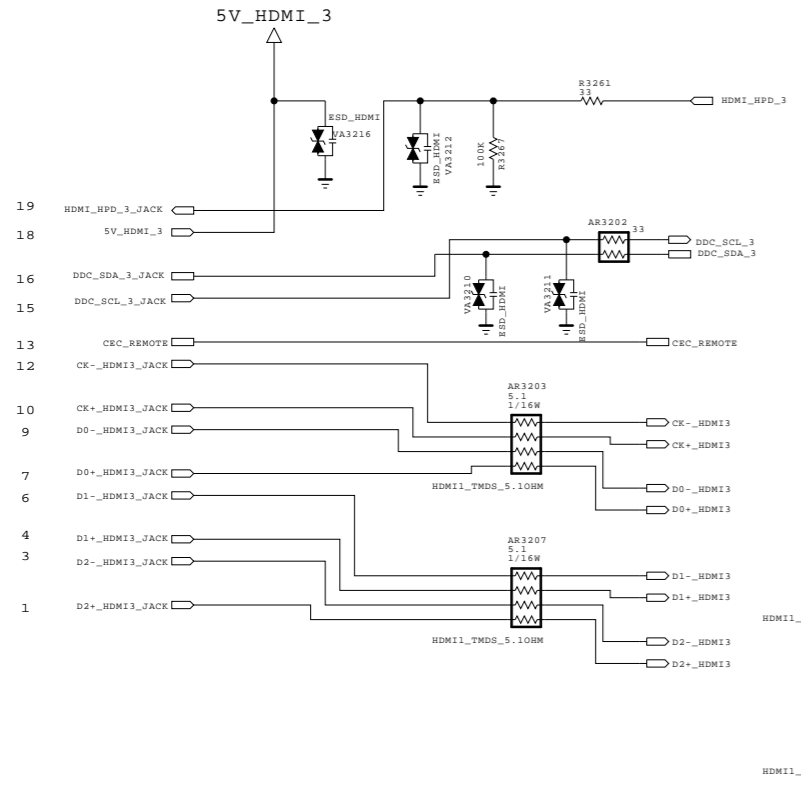

External EDID

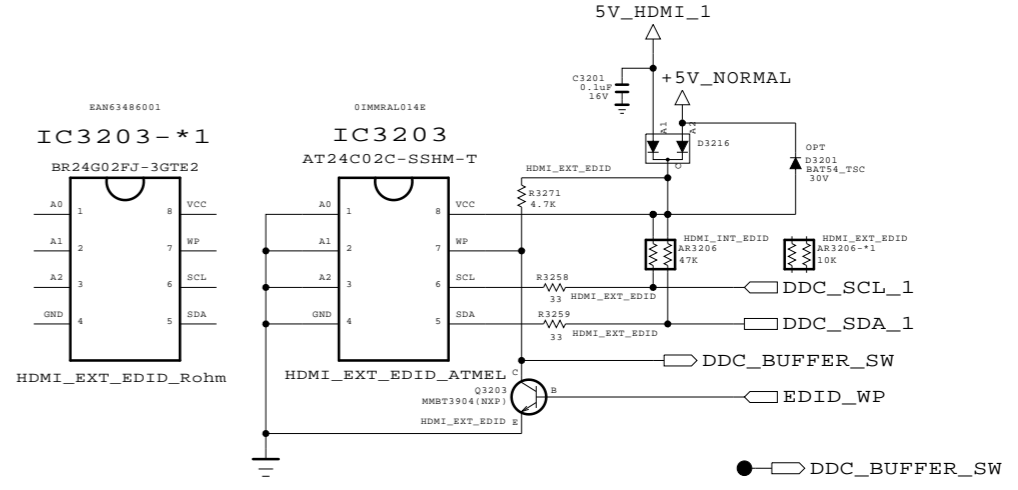

HDMI2 With ARC (2.0)

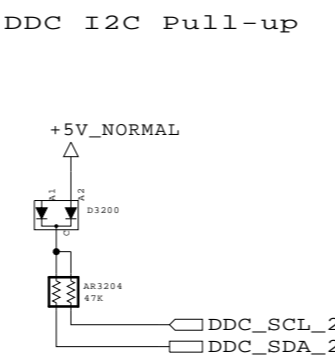
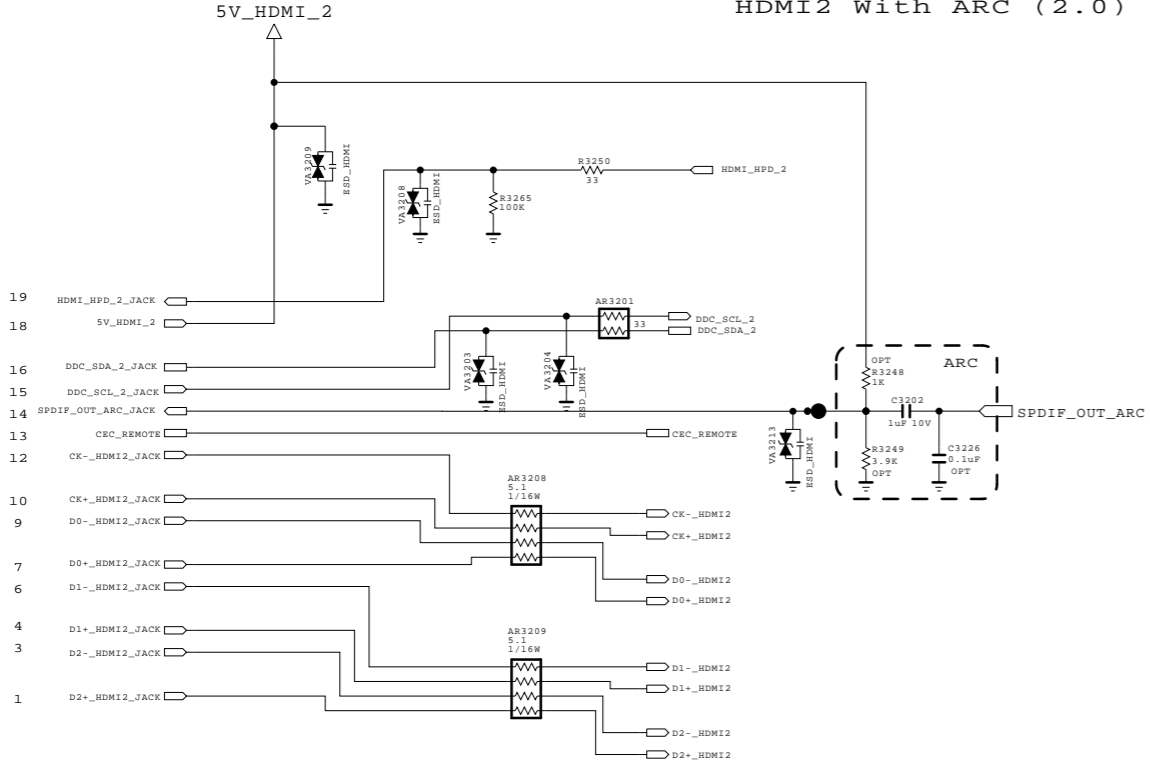

HDMI3 with Ext.EDID (1.4)

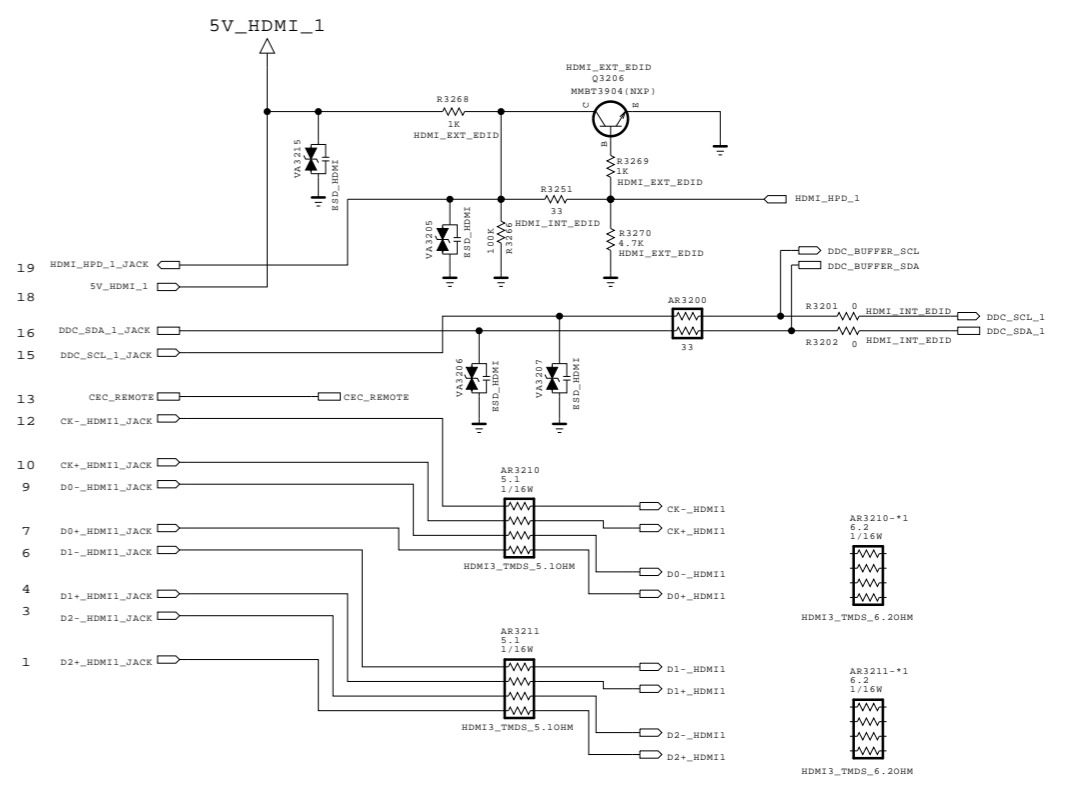

THE Δ SYMBOL MARK OF THIS SCHEMATIC DIAGRAM INCORPORATES SPECIAL FEATURES IMPORTANT FOR PROTECTION FROM X-RADIATION, FIRE AND ELECTRICAL SHOCK HAZARDS, WHEN SERVICING IF IS ESSENTIAL THAT ONLY MANUFACTURERS SPECIFIED PARTS BE USED FOR THE CRITICAL COMPONENTS IN THE Δ SYMBOL MARK OF THE SCHEMATIC.

SECRET
LGElectronics



MODEL	M16	DATE	2015.02.11
BLOCK	HDMI RX	SHEET	12 / 73

EDID external EEPROM & DDC BUFFER for HDMI3

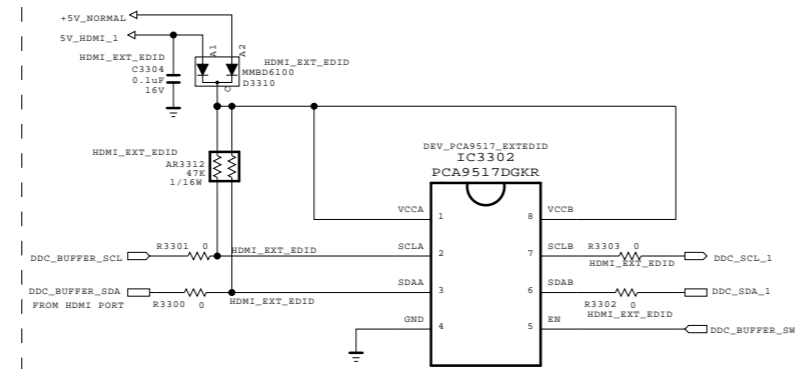

THE SYMBOL MARK OF THIS SCHEMATIC DIAGRAM INCORPORATES SPECIAL FEATURES IMPORTANT FOR PROTECTION FROM X-RADIATION, FIRE AND ELECTRICAL SHOCK HAZARDS, WHEN SERVICING IF IS ESSENTIAL THAT ONLY MANUFACTURERS SPECIFIED PARTS BE USED FOR THE CRITICAL COMPONENTS IN THE SYMBOL MARK OF THE SCHEMATIC.

SECRET
LGElectronics



MODEL	M16	DATE	2015-01-10
BLOCK	HDMI	SHEET	33 /

CVBS 1 PHONE JACK

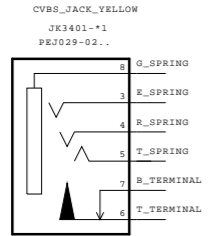
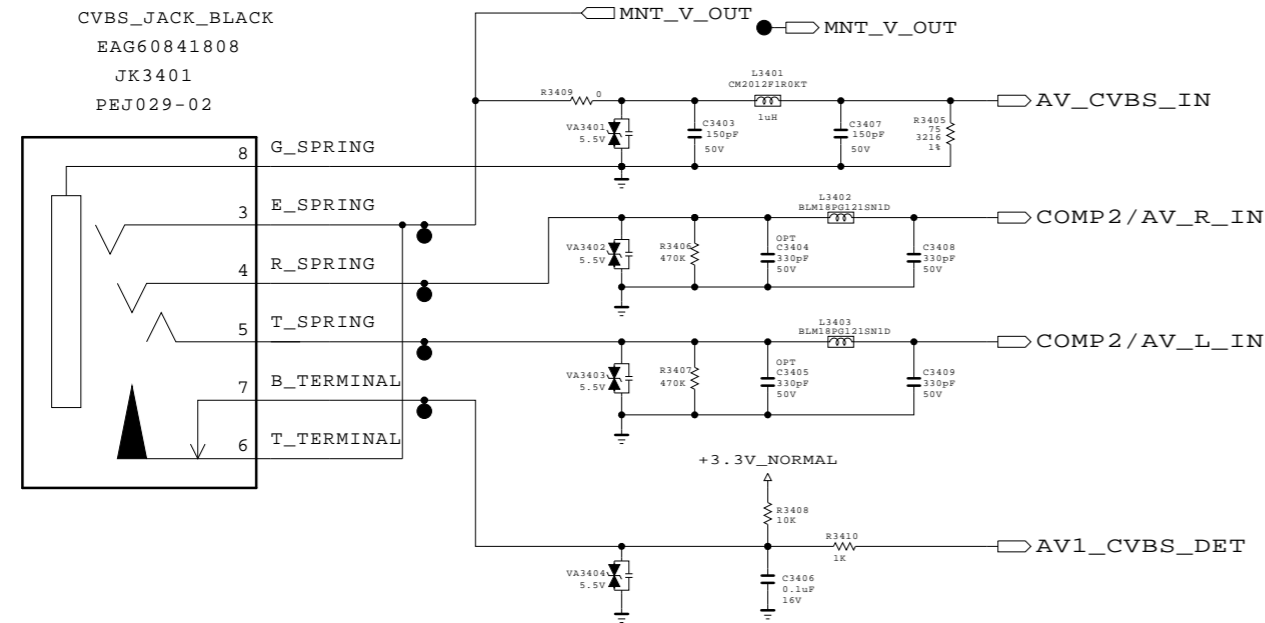

COMPONENT 1 PHONE JACK

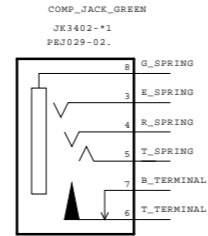
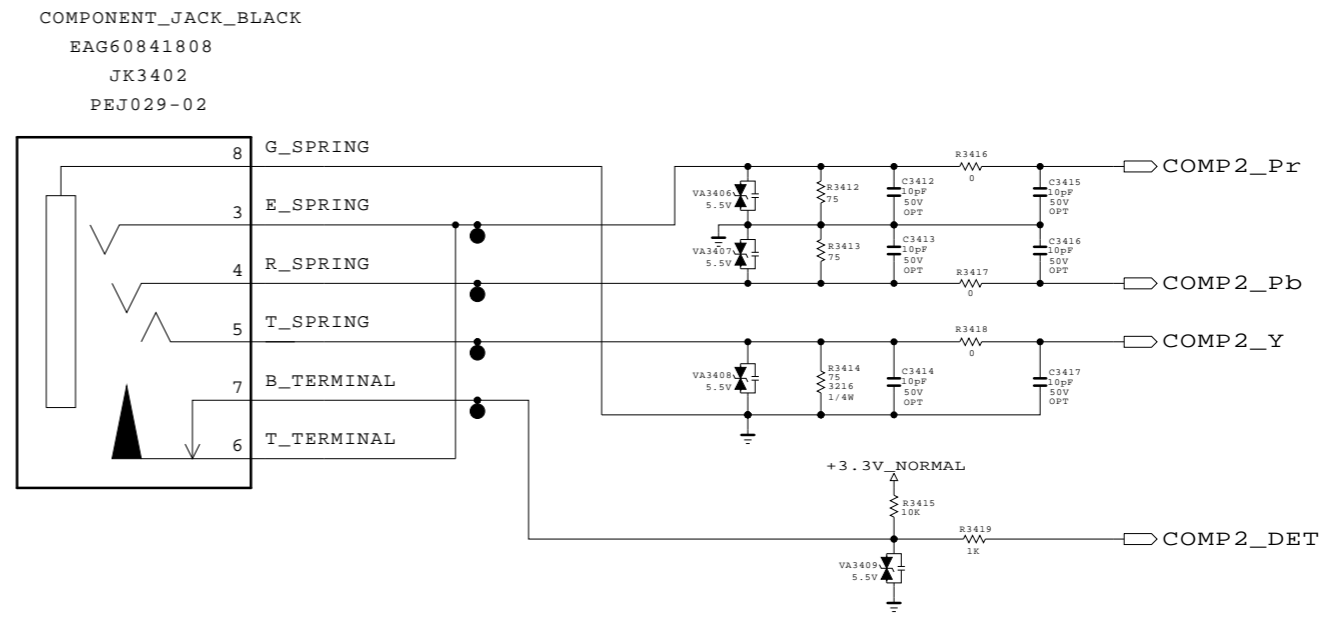

SPDIF OUT

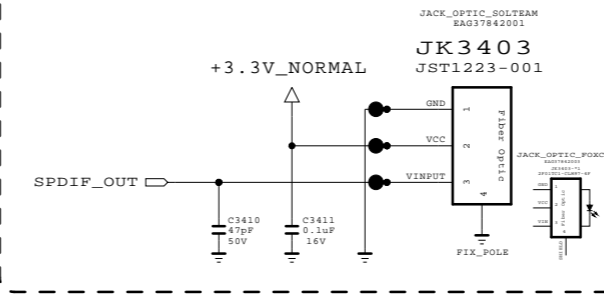

UART for Debug

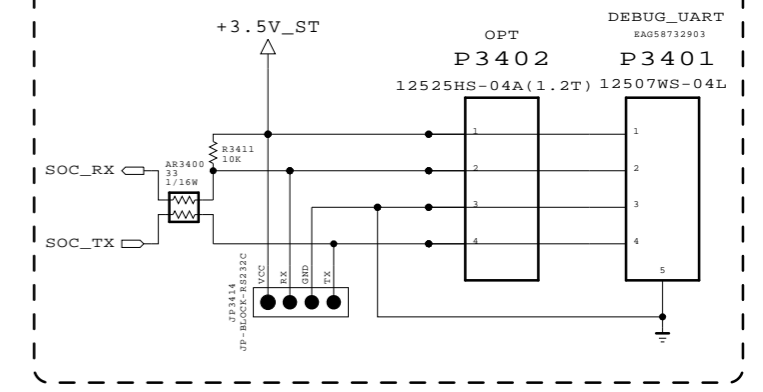

THE Δ SYMBOL MARK OF THIS SCHEMATIC DIAGRAM INCORPORATES SPECIAL FEATURES IMPORTANT FOR PROTECTION FROM X-RADIATION, FIRE AND ELECTRICAL SHOCK HAZARDS, WHEN SERVICING IF IS ESSENTIAL THAT ONLY MANUFACTURERS SPECIFIED PARTS BE USED FOR THE CRITICAL COMPONENTS IN THE Δ SYMBOL MARK OF THE SCHEMATIC.

SECRET
LGElectronics



MODEL	M16	DATE	2015.11.23
BLOCK	JACK_HORIZONTAL	SHEET	34 / 99

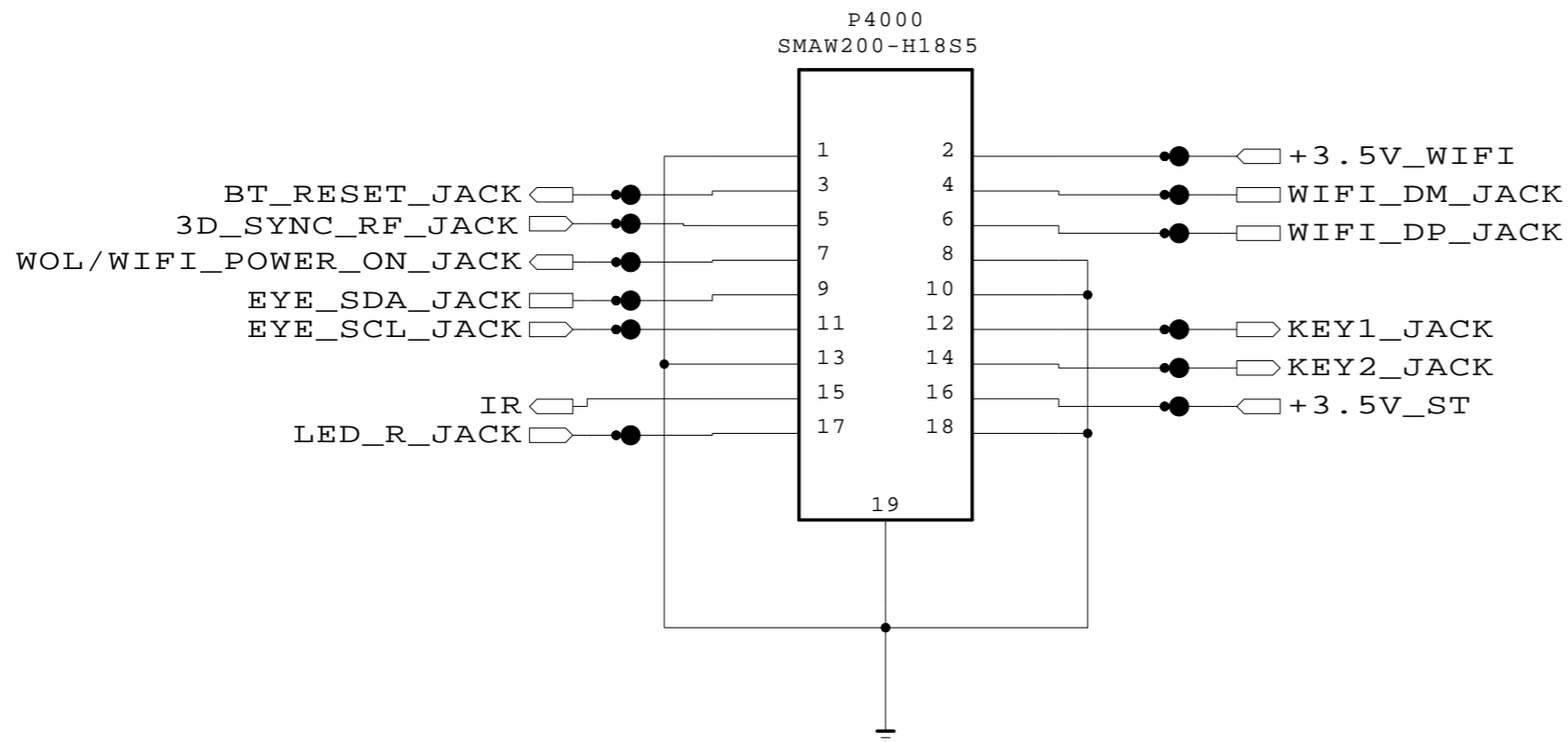

THE ⚠ SYMBOL MARK OF THIS SCHEMATIC DIAGRAM INCORPORATES SPECIAL FEATURES IMPORTANT FOR PROTECTION FROM X-RADIATION. FIRE AND ELECTRICAL SHOCK HAZARDS, WHEN SERVICING IF IS ESSENTIAL THAT ONLY MANUFACTURES SPECIFIED PARTS BE USED FOR THE CRITICAL COMPONENTS IN THE ⚠ SYMBOL MARK OF THE SCHEMATIC.

SECRET
LGElectronics



MODEL	WAFER_IR/KEY/WIFI/BT	DATE	13/06/15
BLOCK		SHEET	40

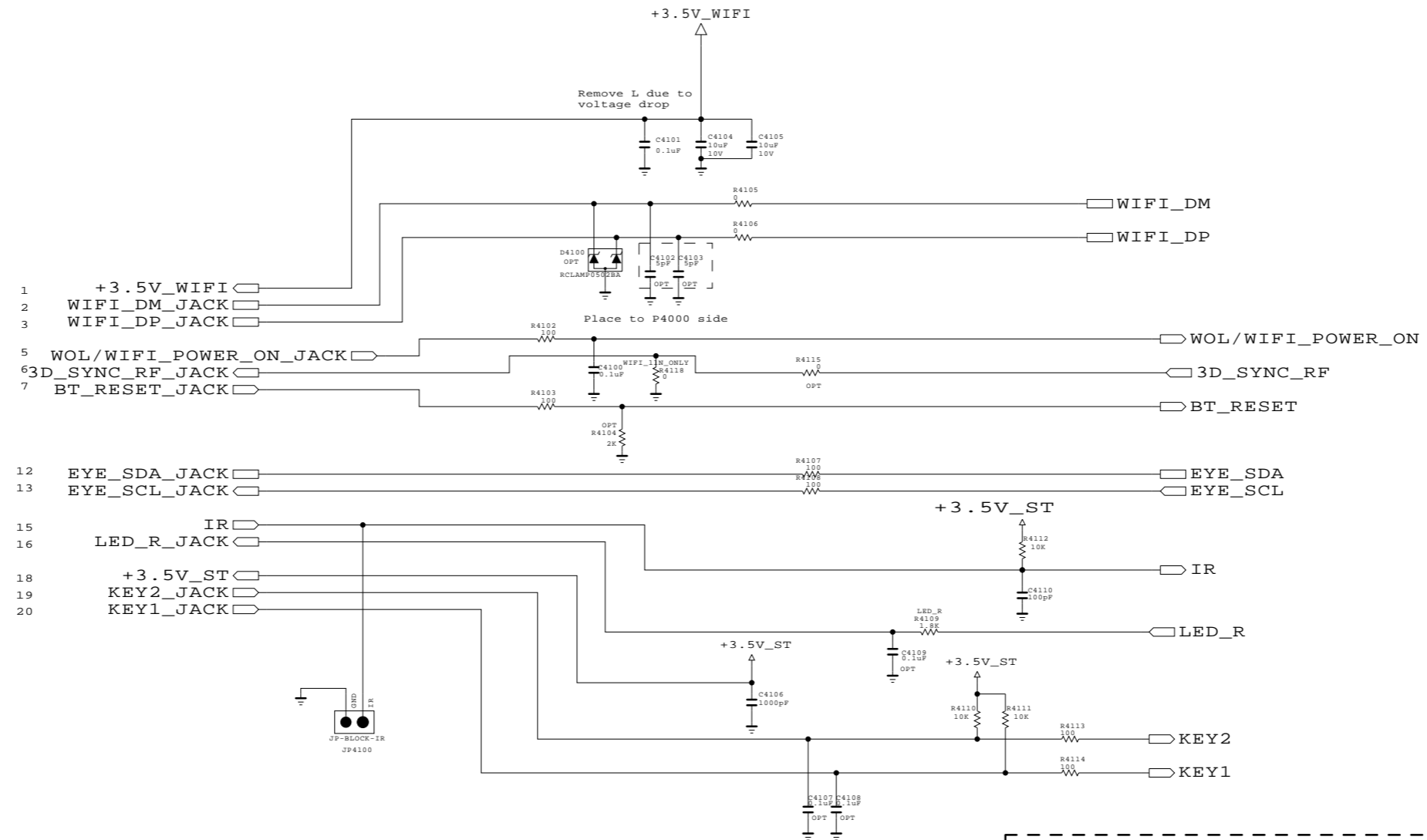

IR Reciever on Board : EV board Only

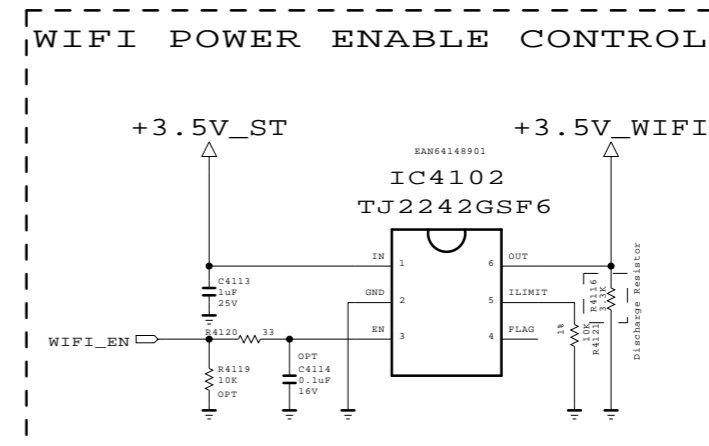
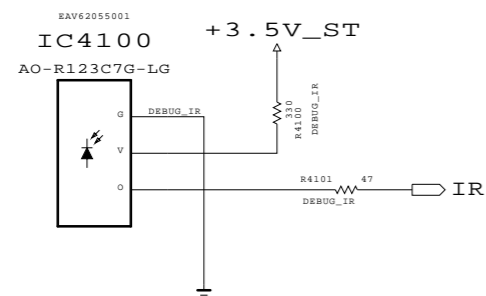

THE Δ SYMBOL MARK OF THIS SCHEMATIC DIAGRAM INCORPORATES SPECIAL FEATURES IMPORTANT FOR PROTECTION FROM X-RADIATION, FIRE AND ELECTRICAL SHOCK HAZARDS, WHEN SERVICING IF IS ESSENTIAL THAT ONLY MANUFACTURERS SPECIFIED PARTS BE USED FOR THE CRITICAL COMPONENTS IN THE Δ SYMBOL MARK OF THE SCHEMATIC.

SECRET
LGElectronics



MODEL	M16	DATE	2015.02.09
BLOCK	IR/KEY/WIFI/BT	SHEET	14 / 73



041.sht

USB3.0
MAX 1.5A

EAG63374203
JK4200
5205-56209

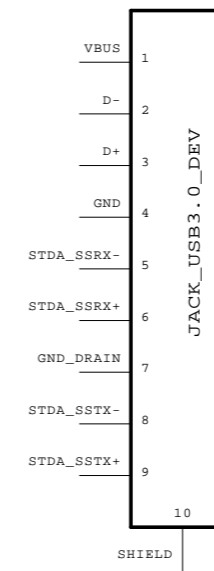
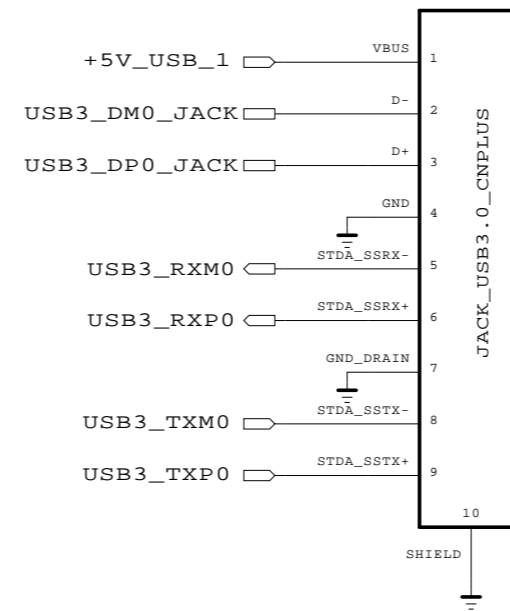
EAG63374205
JK4200-*1
3AG009S-106N3R6003(1.2T PCB)



THE  SYMBOL MARK OF THIS SCHEMATIC DIAGRAM INCORPORATES SPECIAL FEATURES IMPORTANT FOR PROTECTION FROM X-RADIATION. FIRE AND ELECTRICAL SHOCK HAZARDS, WHEN SERVICING IF IS ESSENTIAL THAT ONLY MANUFACTURES SPECIFIED PARTS BE USED FOR THE CRITICAL COMPONENTS IN THE  SYMBOL MARK OF THE SCHEMATIC.

SECRET
LGElectronics



MODEL		DATE	15/06/13
BLOCK	JACK_USB1_3.0	SHEET	/ 73

USB3.0
MAX 1.5A

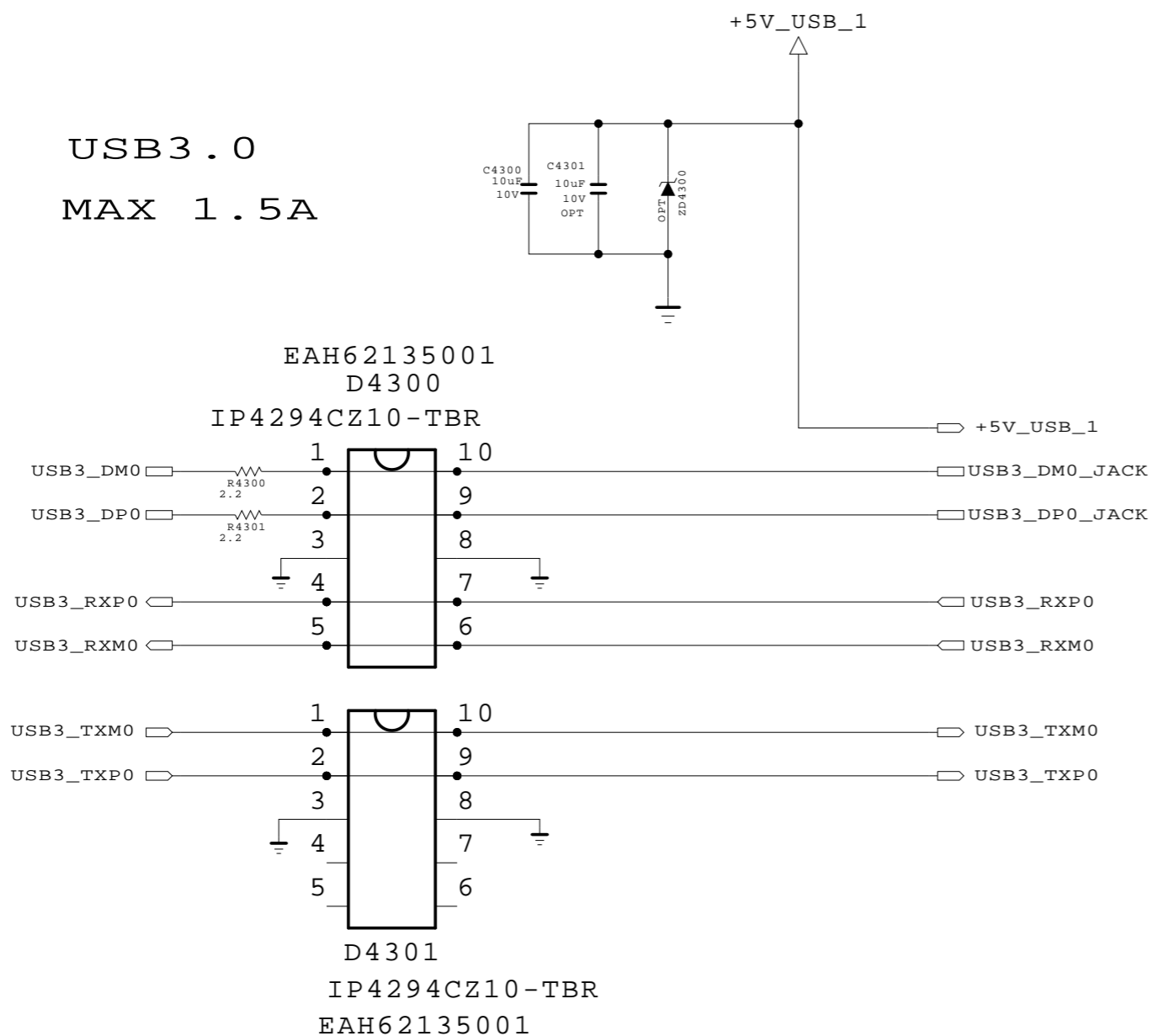

OCP USB3.0

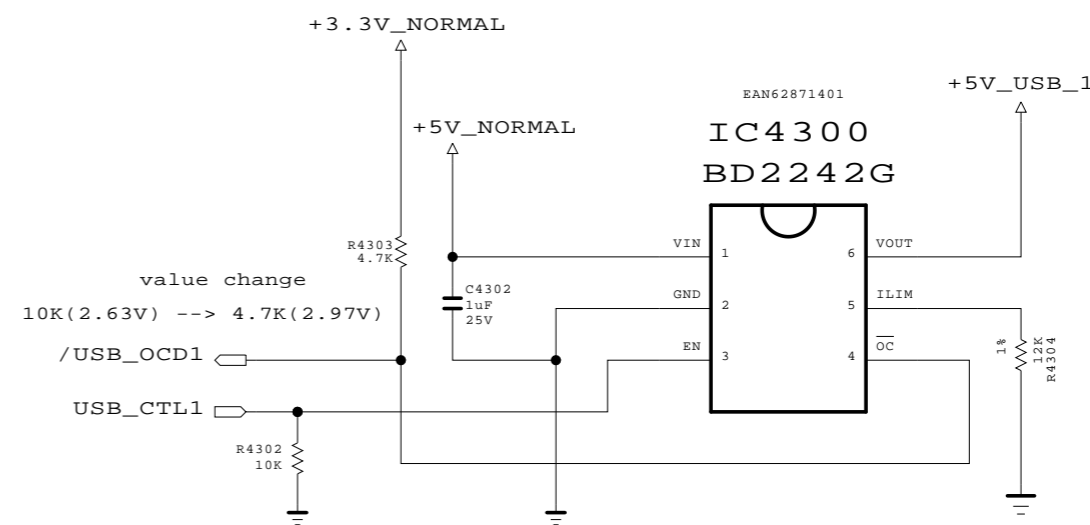

THE SYMBOL MARK OF THIS SCHEMATIC DIAGRAM INCORPORATES SPECIAL FEATURES IMPORTANT FOR PROTECTION FROM X-RADIATION. FIRE AND ELECTRICAL SHOCK HAZARDS, WHEN SERVICING IT IS ESSENTIAL THAT ONLY MANUFACTURERS SPECIFIED PARTS BE USED FOR THE CRITICAL COMPONENTS IN THE SYMBOL MARK OF THE SCHEMATIC.

SECRET	LG ELECTRONICS
LGElectronics	

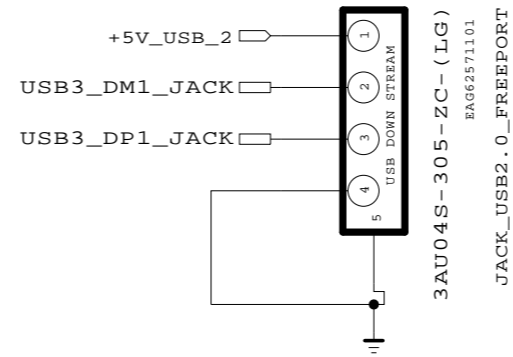

MODEL	M16	DATE	2015.11.23
BLOCK	USB1_3.0	SHEET	43 / 99

USB2 (2.0)
MAX 1.5A JK4400

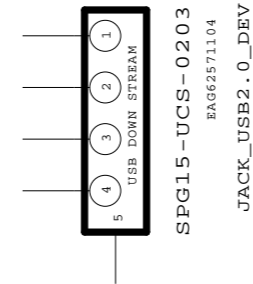

JK4400-*1



THE  SYMBOL MARK OF THIS SCHEMATIC DIAGRAM INCORPORATES SPECIAL FEATURES IMPORTANT FOR PROTECTION FROM X-RADIATION. FIRE AND ELECTRICAL SHOCK HAZARDS, WHEN SERVICING IF IS ESSENTIAL THAT ONLY MANUFACTURES SPECIFIED PARTS BE USED FOR THE CRITICAL COMPONENTS IN THE  SYMBOL MARK OF THE SCHEMATIC.

SECRET
LGElectronics



MODEL		DATE	15/06/13
BLOCK	JACK_USB2_2.0	SHEET	/ 73

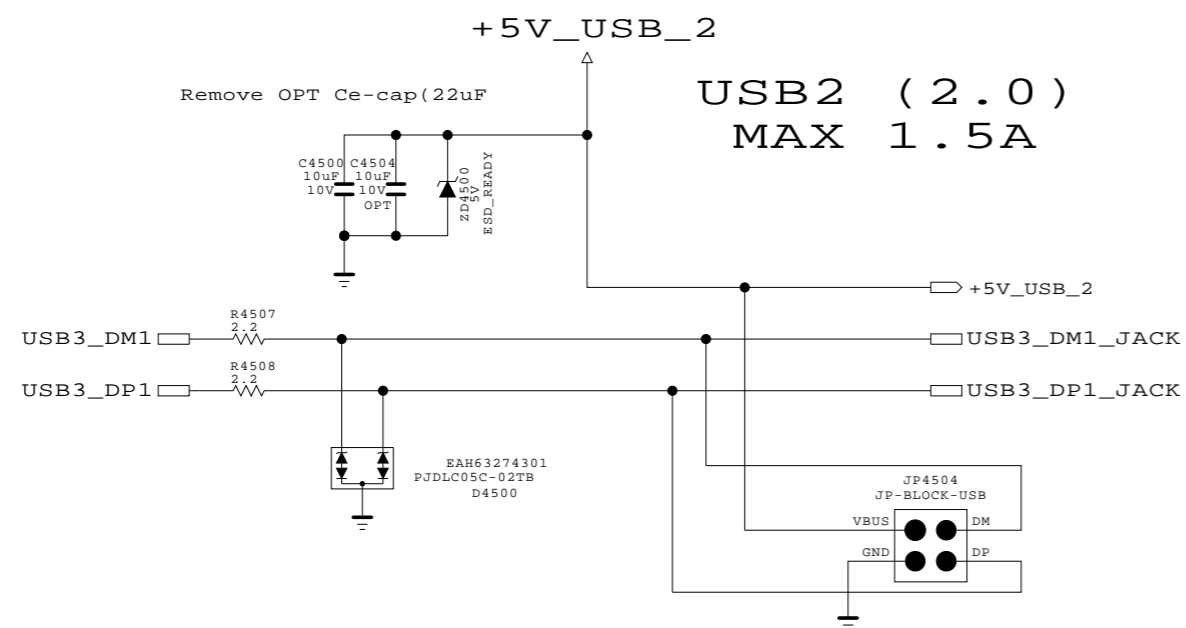

OCP USB2_2.0

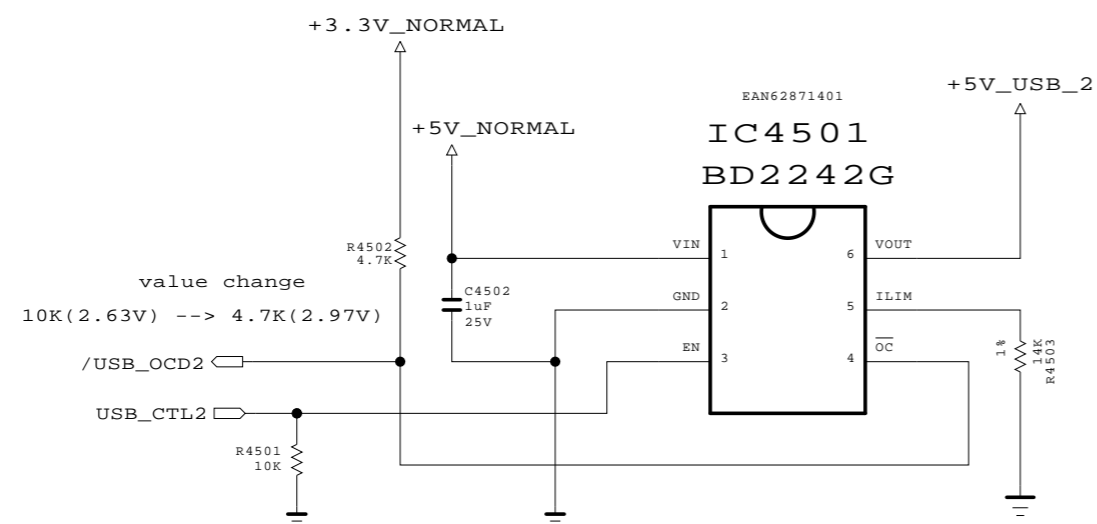

THE SYMBOL MARK OF THIS SCHEMATIC DIAGRAM INCORPORATES SPECIAL FEATURES IMPORTANT FOR PROTECTION FROM X-RADIATION. FIRE AND ELECTRICAL SHOCK HAZARDS, WHEN SERVICING IF IS ESSENTIAL THAT ONLY MANUFACTURES SPECIFIED PARTS BE USED FOR THE CRITICAL COMPONENTS IN THE SYMBOL MARK OF THE SCHEMATIC.

SECRET	LG ELECTRONICS
LGElectronics	

MODEL	M16	DATE	2015.11.23
BLOCK	USB2_2.0	SHEET	45 / 99

USB3 (2.0)
MAX 1.5A JK4600

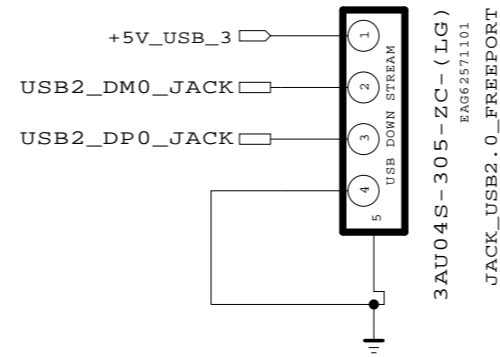

JK4600-*1

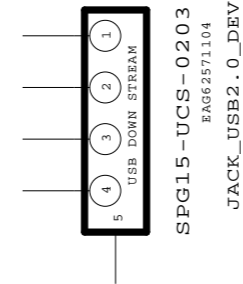

THE SYMBOL MARK OF THIS SCHEMATIC DIAGRAM INCORPORATES SPECIAL FEATURES IMPORTANT FOR PROTECTION FROM X-RADIATION. FIRE AND ELECTRICAL SHOCK HAZARDS, WHEN SERVICING IF IS ESSENTIAL THAT ONLY MANUFACTURES SPECIFIED PARTS BE USED FOR THE CRITICAL COMPONENTS IN THE SYMBOL MARK OF THE SCHEMATIC.

SECRET
LGElectronics



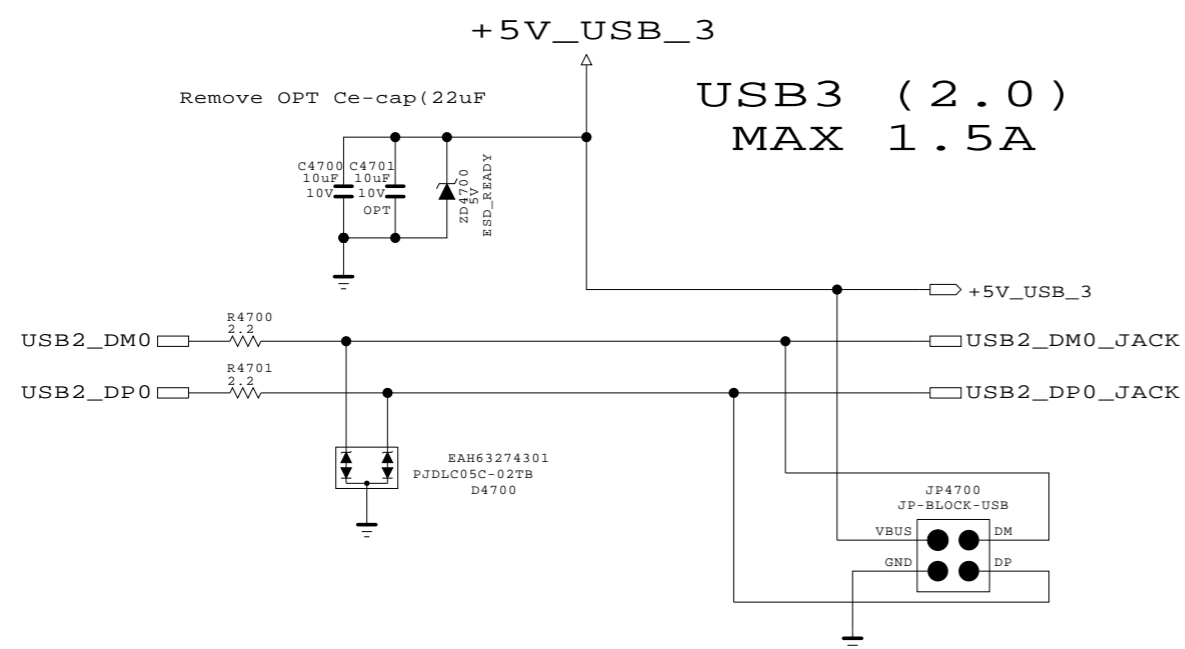

MODEL		DATE	15/06/13
BLOCK	JACK_USB3_2.0	SHEET	/ 73

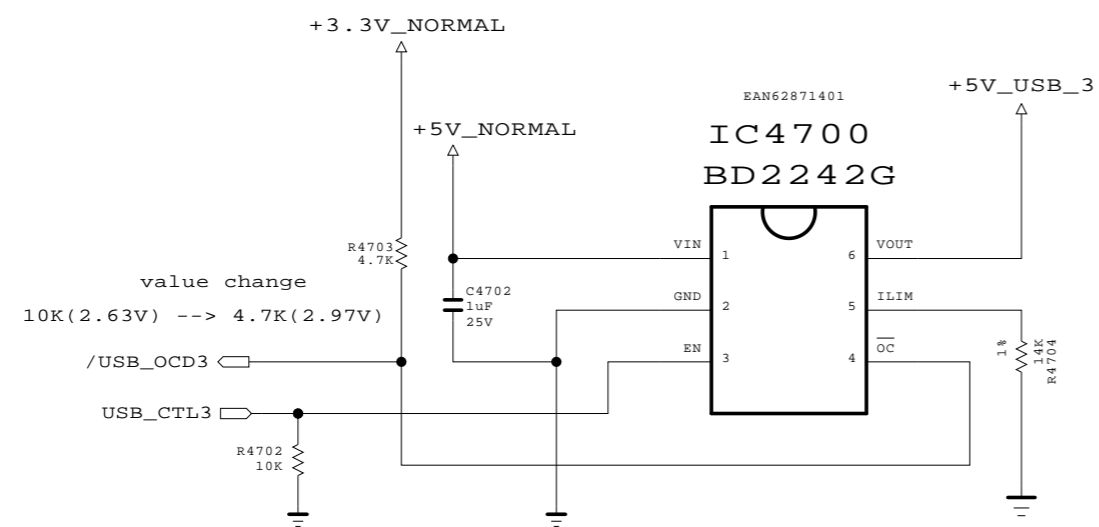

OCP USB3_2.0



THE  SYMBOL MARK OF THIS SCHEMATIC DIAGRAM INCORPORATES SPECIAL FEATURES IMPORTANT FOR PROTECTION FROM X-RADIATION. FIRE AND ELECTRICAL SHOCK HAZARDS, WHEN SERVICING IF IS ESSENTIAL THAT ONLY MANUFACTURERS SPECIFIED PARTS BE USED FOR THE CRITICAL COMPONENTS IN THE  SYMBOL MARK OF THE SCHEMATIC.

SECRET	 LG ELECTRONICS
LGElectronics	

MODEL	M16	DATE	2015.11.23
BLOCK	USB3_2.0	SHEET	47 / 99

Ethernet Block

JACK_LAN_DEV
EAG35781017
JK5000-*1
BS_RV30289

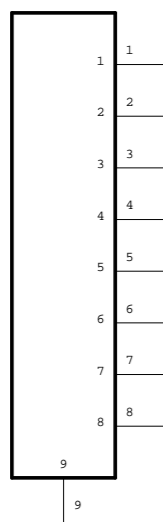

JACK_LAN_UDE
EAG35781010
JK5000
RJ45VT-01SN002

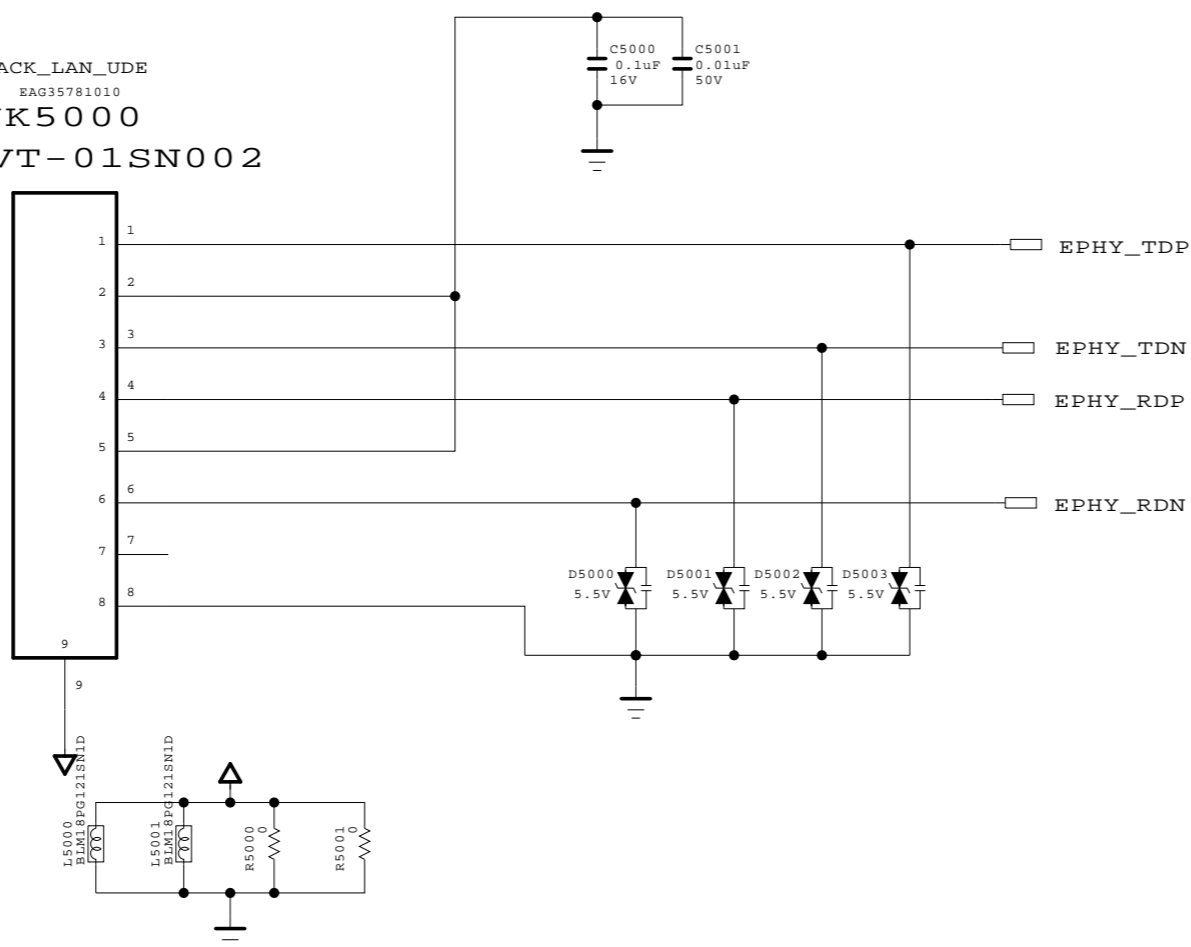

THE SYMBOL MARK OF THIS SCHEMATIC DIAGRAM INCORPORATES SPECIAL FEATURES IMPORTANT FOR PROTECTION FROM X-RADIATION. FIRE AND ELECTRICAL SHOCK HAZARDS, WHEN SERVICING IF IS ESSENTIAL THAT ONLY MANUFACTURERS SPECIFIED PARTS BE USED FOR THE CRITICAL COMPONENTS IN THE SYMBOL MARK OF THE SCHEMATIC.

SECRET	LG ELECTRONICS
LGElectronics	

MODEL	M16	DATE	2015.02.09
BLOCK	ETHERNET JACK	SHEET	18 / 26

050.sht

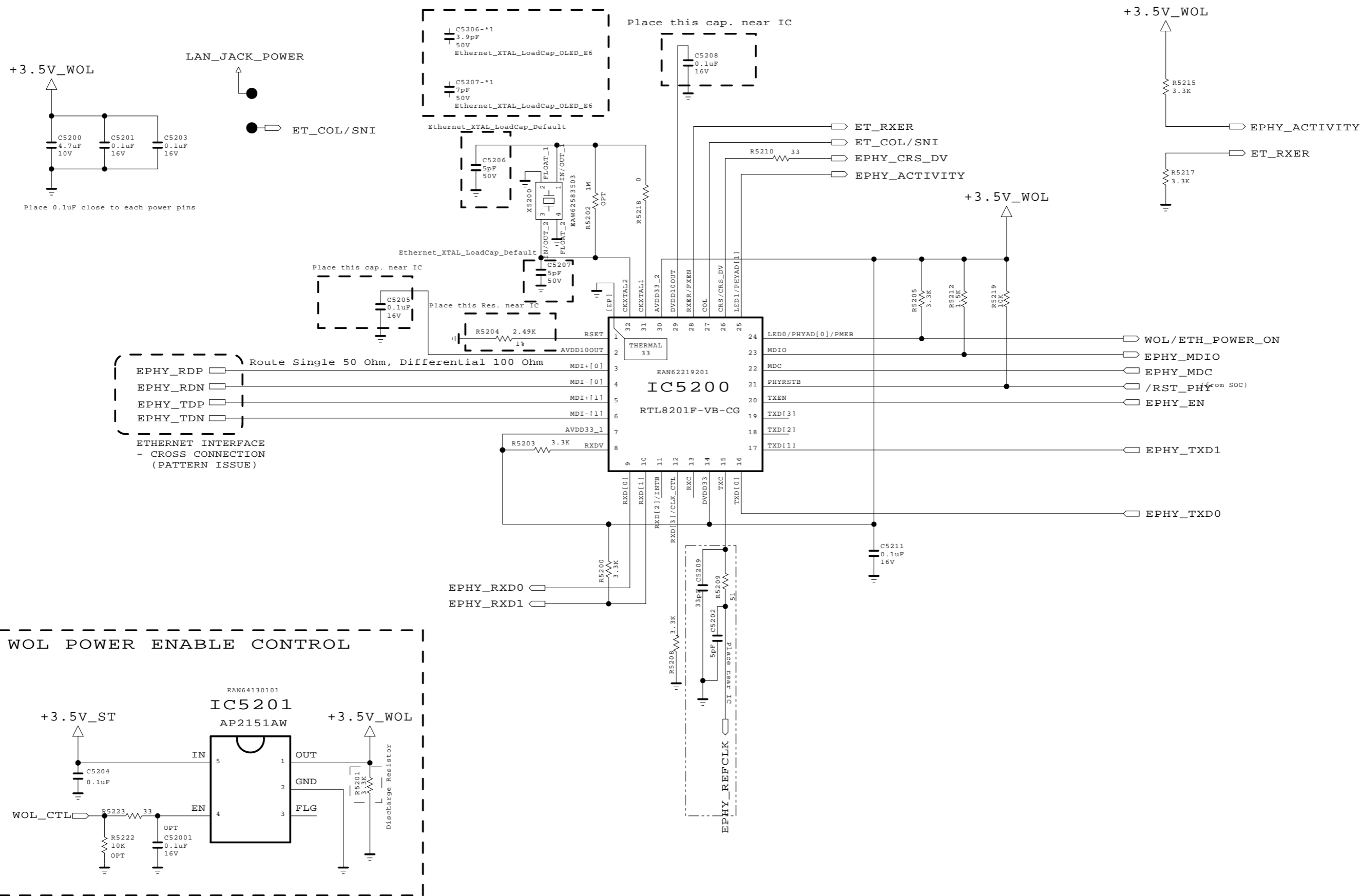

THE ⚠ SYMBOL MARK OF THIS SCHEMATIC DIAGRAM INCORPORATES SPECIAL FEATURES IMPORTANT FOR PROTECTION FROM X-RADIATION. FIRE AND ELECTRICAL SHOCK HAZARDS, WHEN SERVICING IF IS ESSENTIAL THAT ONLY MANUFACTURES SPECIFIED PARTS BE USED FOR THE CRITICAL COMPONENTS IN THE ⚠ SYMBOL MARK OF THE SCHEMATIC.

SECRET	
LGElectronics	

MODEL	M16	DATE	2015.11.04
BLOCK	LAN	SHEET	52 / 100

NTP_AMP_Front

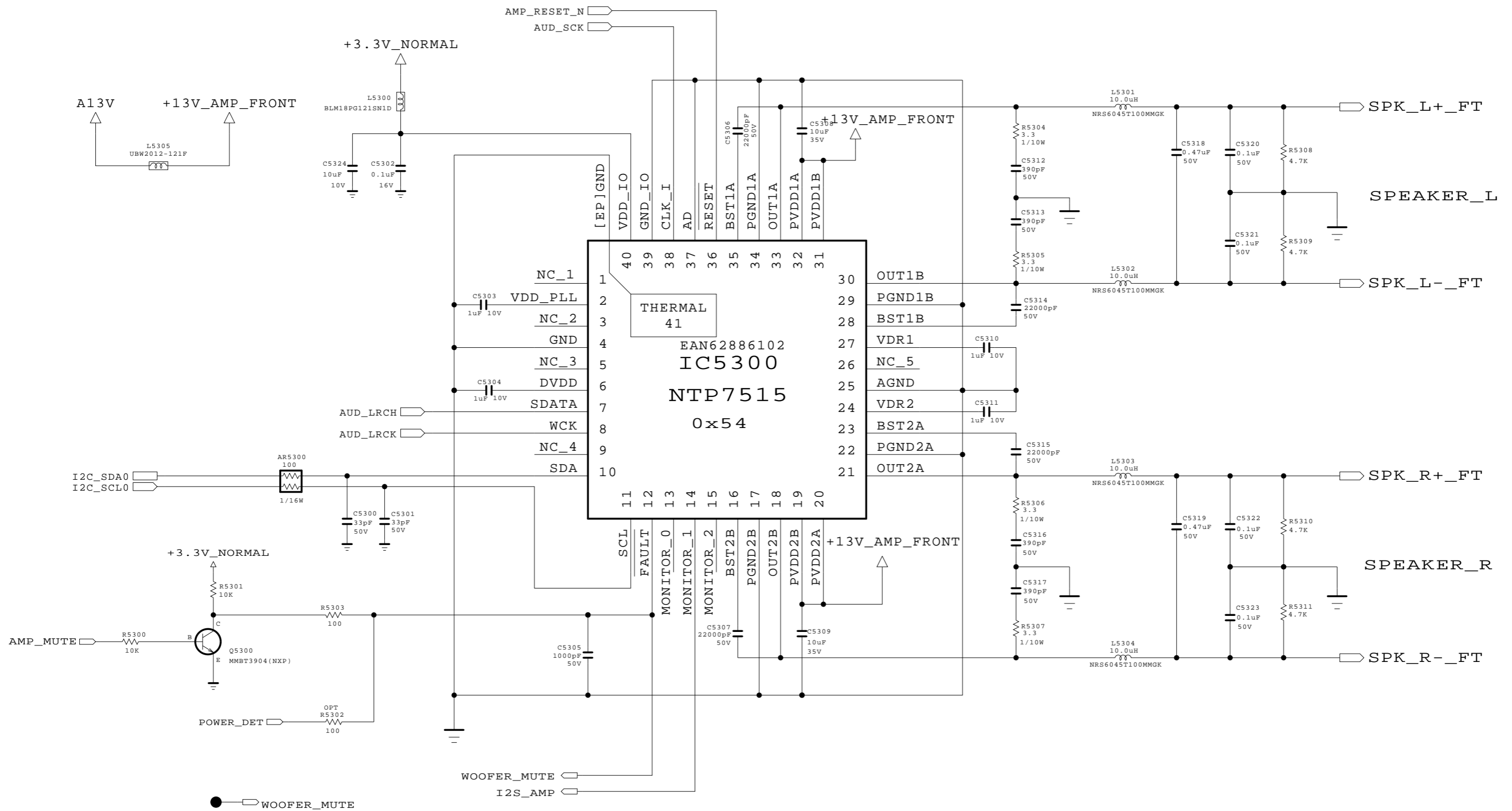

THE SYMBOL MARK OF THIS SCHEMATIC DIAGRAM INCORPORATES SPECIAL FEATURES IMPORTANT FOR PROTECTION FROM X-RADIATION. FIRE AND ELECTRICAL SHOCK HAZARDS, WHEN SERVICING IF IS ESSENTIAL THAT ONLY MANUFACTURERS SPECIFIED PARTS BE USED FOR THE CRITICAL COMPONENTS IN THE SYMBOL MARK OF THE SCHEMATIC.

SECRET
LGElectronics



MODEL	M16	DATE	2015.02.24
BLOCK	NTP AMP	SHEET	20 / 26

053.sht

AMP - Center (Upper 75") Woofer (Below 65") Tweeter (EH92)

Option Description

1. SDATA_TWEETER : Use the AMP for Tweeter (EH92)
2. SDATA_WOOFER/CENTER : Use this AMP for Center (upper 75inch model) or Woofer STEREO (below 65 inch model)

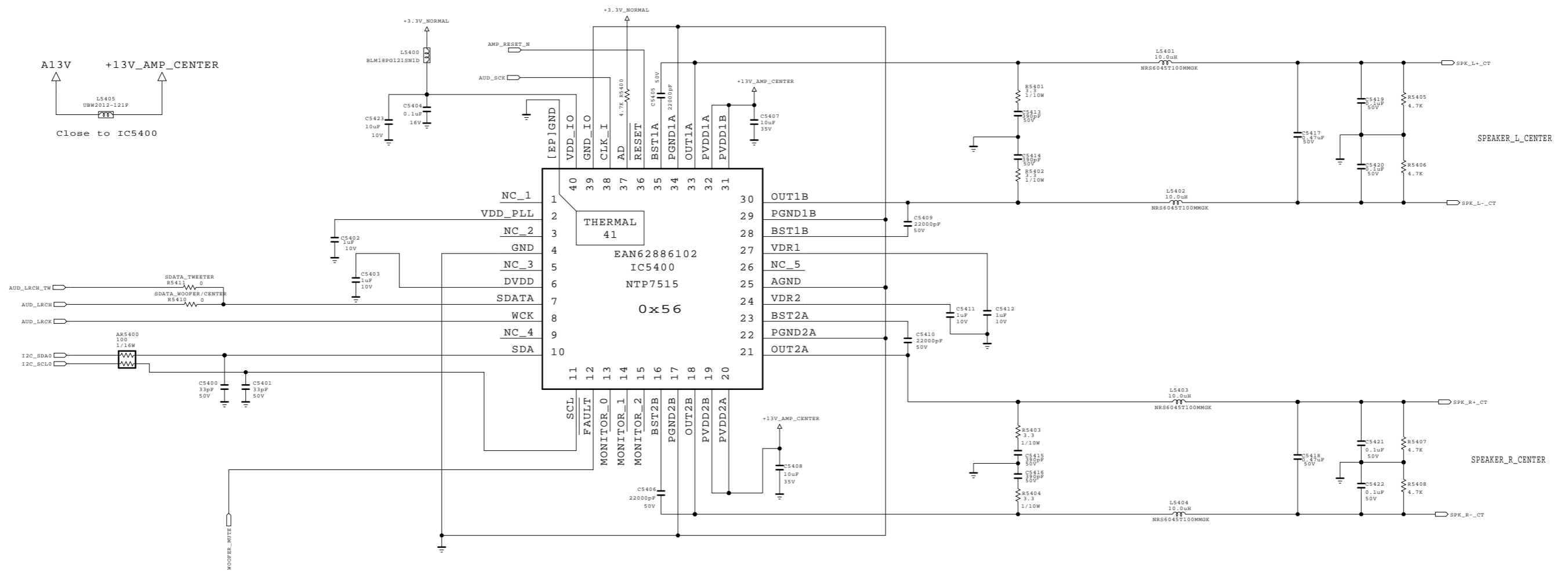

THE Δ SYMBOL MARK OF THIS SCHEMATIC DIAGRAM INCORPORATES SPECIAL FEATURES IMPORTANT FOR PROTECTION FROM X-RADIATION, FIRE AND ELECTRICAL SHOCK HAZARDS, WHEN SERVICING IT IS ESSENTIAL THAT ONLY MANUFACTURERS SPECIFIED PARTS BE USED FOR THE CRITICAL COMPONENTS IN THE Δ SYMBOL MARK OF THE SCHEMATIC.

SECRET
 LGElectronics



MODEL	M16	DATE	2015.06.27
BLOCK	AMP_CENTER/WOOFER	SHEET	54 / 99

AMP (NTP7515) - Woofer_L

Option name : SPK_Woofers_L (PBTL)

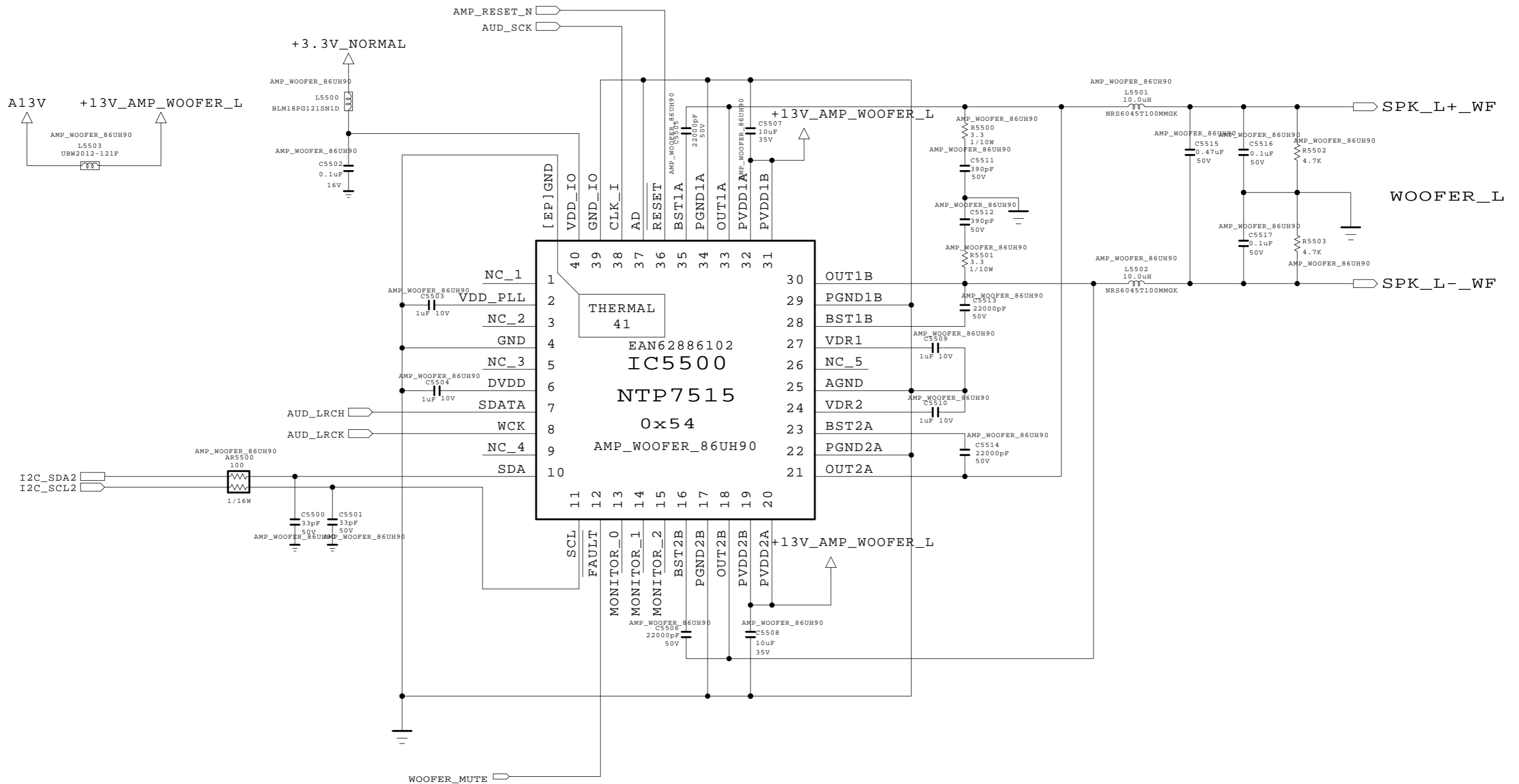

THE ⚠ SYMBOL MARK OF THIS SCHEMATIC DIAGRAM INCORPORATES SPECIAL FEATURES IMPORTANT FOR PROTECTION FROM X-RADIATION. FIRE AND ELECTRICAL SHOCK HAZARDS, WHEN SERVICING IF IS ESSENTIAL THAT ONLY MANUFACTURES SPECIFIED PARTS BE USED FOR THE CRITICAL COMPONENTS IN THE ⚠ SYMBOL MARK OF THE SCHEMATIC.

SECRET
LGElectronics



MODEL	M16	DATE	2015.02.24
BLOCK	AMP[NTP7515] PBTL	SHEET	55 /

055.sht

AMP (NTP7515) - Woofer_R

Option name : SPK_WoofeR_R(PBTL)

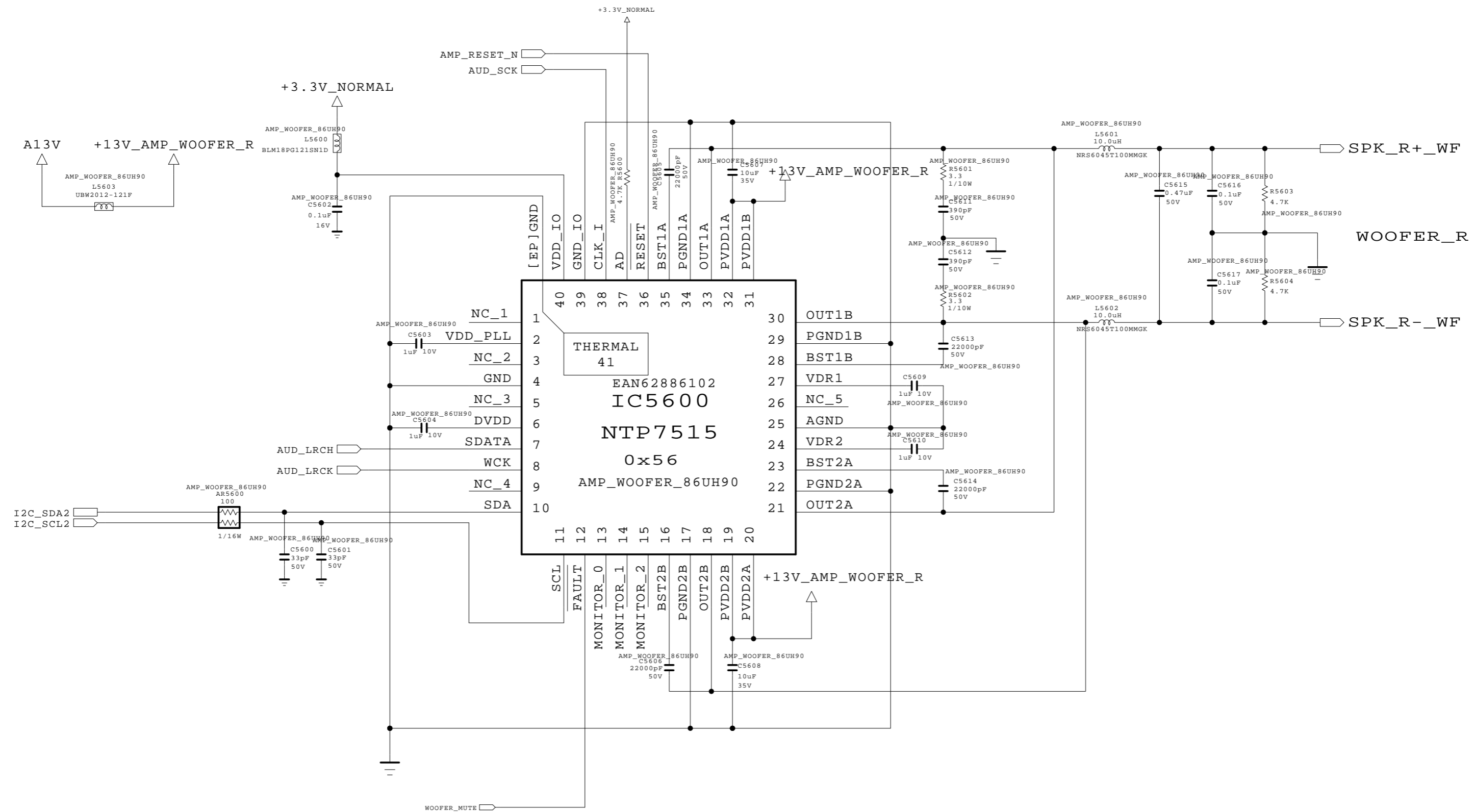

THE ⚠ SYMBOL MARK OF THIS SCHEMATIC DIAGRAM INCORPORATES SPECIAL FEATURES IMPORTANT FOR PROTECTION FROM X-RADIATION. FIRE AND ELECTRICAL SHOCK HAZARDS, WHEN SERVICING IF IS ESSENTIAL THAT ONLY MANUFACTURES SPECIFIED PARTS BE USED FOR THE CRITICAL COMPONENTS IN THE ⚠ SYMBOL MARK OF THE SCHEMATIC.

SECRET	LG ELECTRONICS
LGElectronics	

MODEL		DATE	
BLOCK		SHEET	/

056.sht

AMP (NTP7515) - Tweeter

Option name : AMP_TWEETER

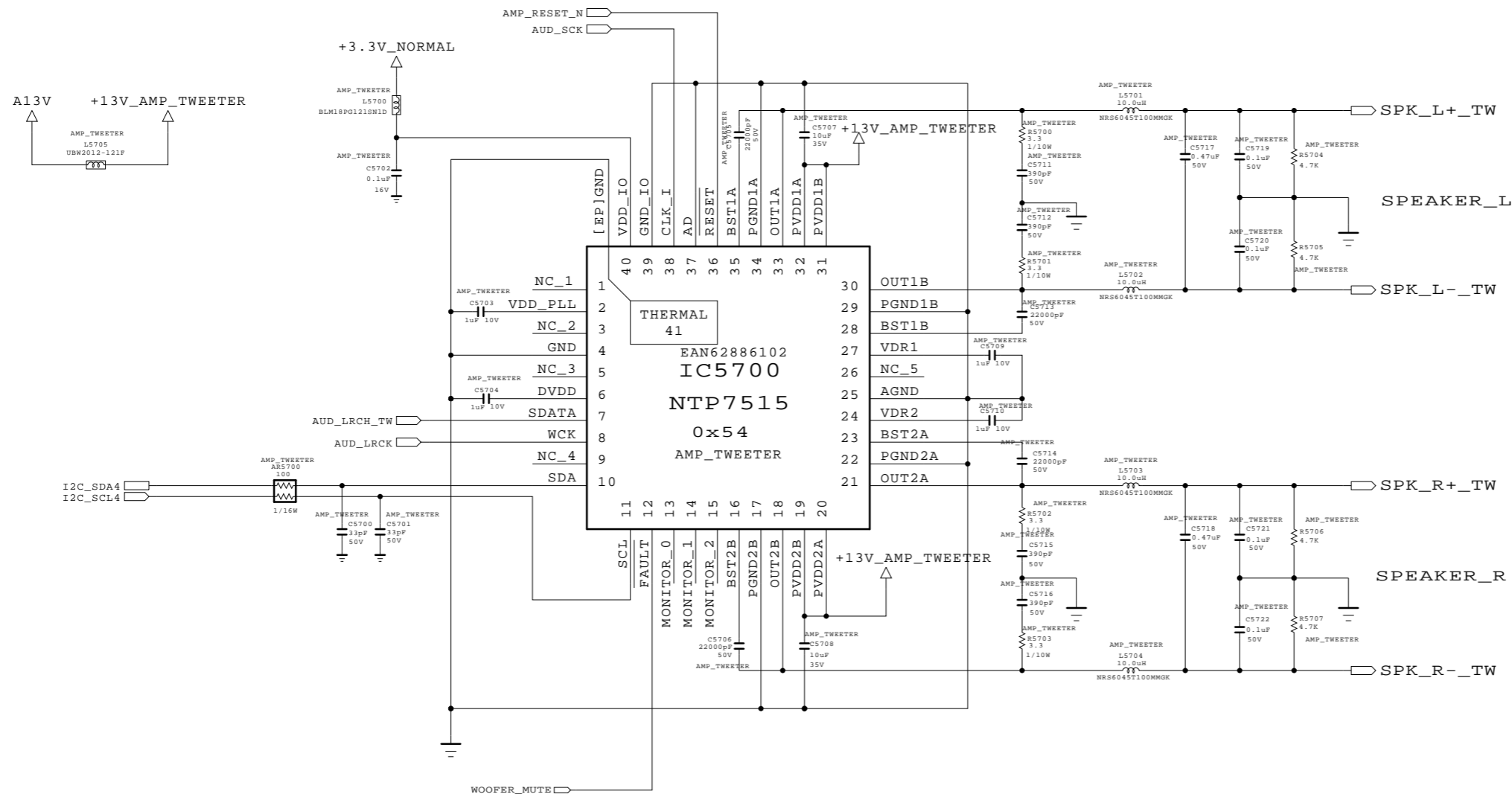

057.sht

THE SYMBOL MARK OF THIS SCHEMATIC DIAGRAM INCORPORATES SPECIAL FEATURES IMPORTANT FOR PROTECTION FROM X-RADIATION, FIRE AND ELECTRICAL SHOCK HAZARDS, WHEN SERVICING IT IS ESSENTIAL THAT ONLY MANUFACTURERS SPECIFIED PARTS BE USED FOR THE CRITICAL COMPONENTS IN THE SYMBOL MARK OF THE SCHEMATIC.



SECRET
LGElectronics

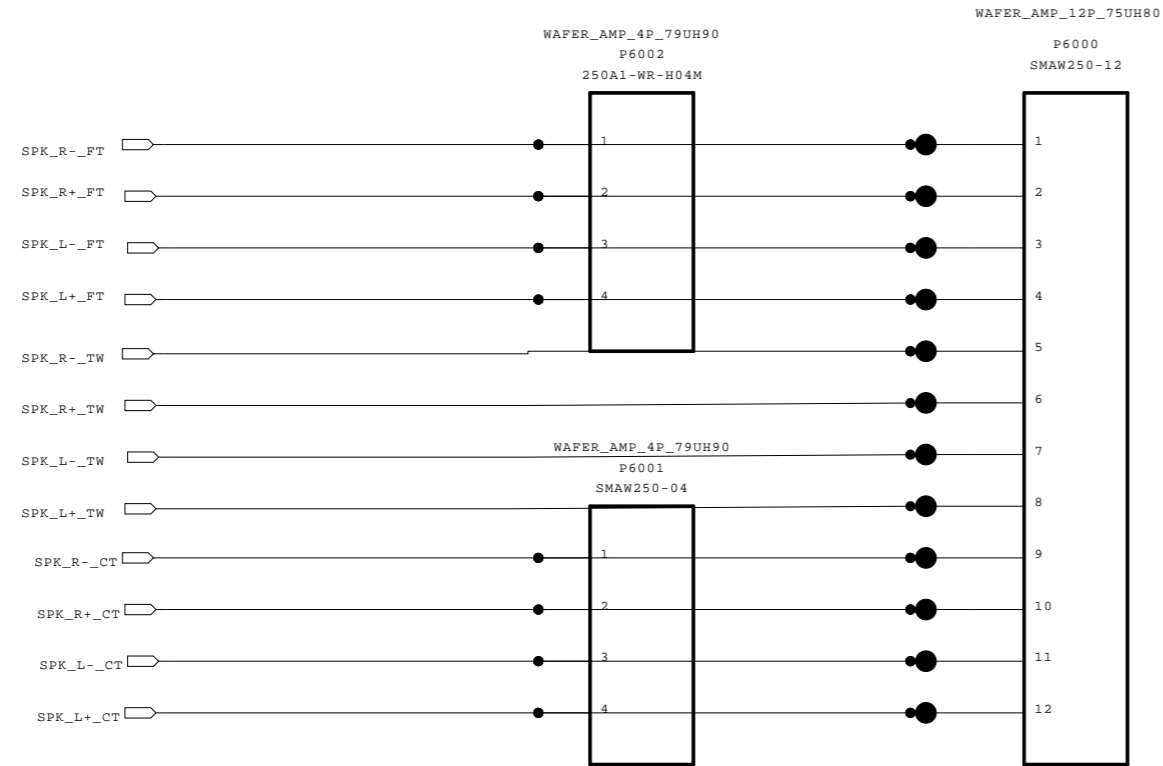

MODEL		DATE	
BLOCK		SHEET	/

WAFER_AMP_4P_12P_TWEETER



THE  SYMBOL MARK OF THIS SCHEMATIC DIAGRAM INCORPORATES SPECIAL FEATURES IMPORTANT FOR PROTECTION FROM X-RADIATION. FIRE AND ELECTRICAL SHOCK HAZARDS, WHEN SERVICING IF IS ESSENTIAL THAT ONLY MANUFACTURERS SPECIFIED PARTS BE USED FOR THE CRITICAL COMPONENTS IN THE  SYMBOL MARK OF THE SCHEMATIC.

SECRET	 LG ELECTRONICS
LGElectronics	

MODEL		DATE	
BLOCK		SHEET	/

060.sht

WAFER_AMP_16P_WOOFER

WAFER_AMP_16P_WOOFER
P6100
SMAW250-12



WAFER_AMP_16P_WOOFER
P6101
250A1-WR-H04M

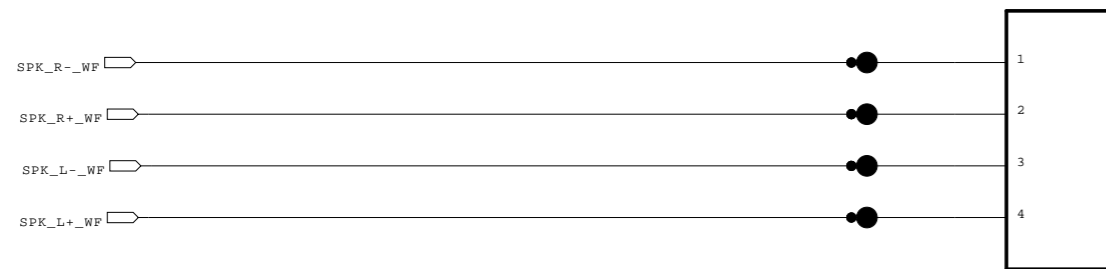

AMP QTY	APPLY MODEL	FRONT	TWEETER	CENTER	WOOFER_L (PBT)	WOOFER_R (PBT)
1AMP	UH59, UH65, UH75	○				
2AMP	79UH90 70UH75 UH80 EH95	○		○ (WOOFER)		
2AMP	EH92	○		○ (TWEETER)		
3AMP	75UH80	○	○	○ (WOOFER)		
5AMP	86UH80	○	○	○ (CENTER)	○	○

THE ⚠ SYMBOL MARK OF THIS SCHEMATIC DIAGRAM INCORPORATES SPECIAL FEATURES IMPORTANT FOR PROTECTION FROM X-RADIATION. FIRE AND ELECTRICAL SHOCK HAZARDS, WHEN SERVICING IF IS ESSENTIAL THAT ONLY MANUFACTURES SPECIFIED PARTS BE USED FOR THE CRITICAL COMPONENTS IN THE ⚠ SYMBOL MARK OF THE SCHEMATIC.

SECRET	 LG ELECTRONICS
LGElectronics	

MODEL		DATE	
BLOCK		SHEET	/

061.sht

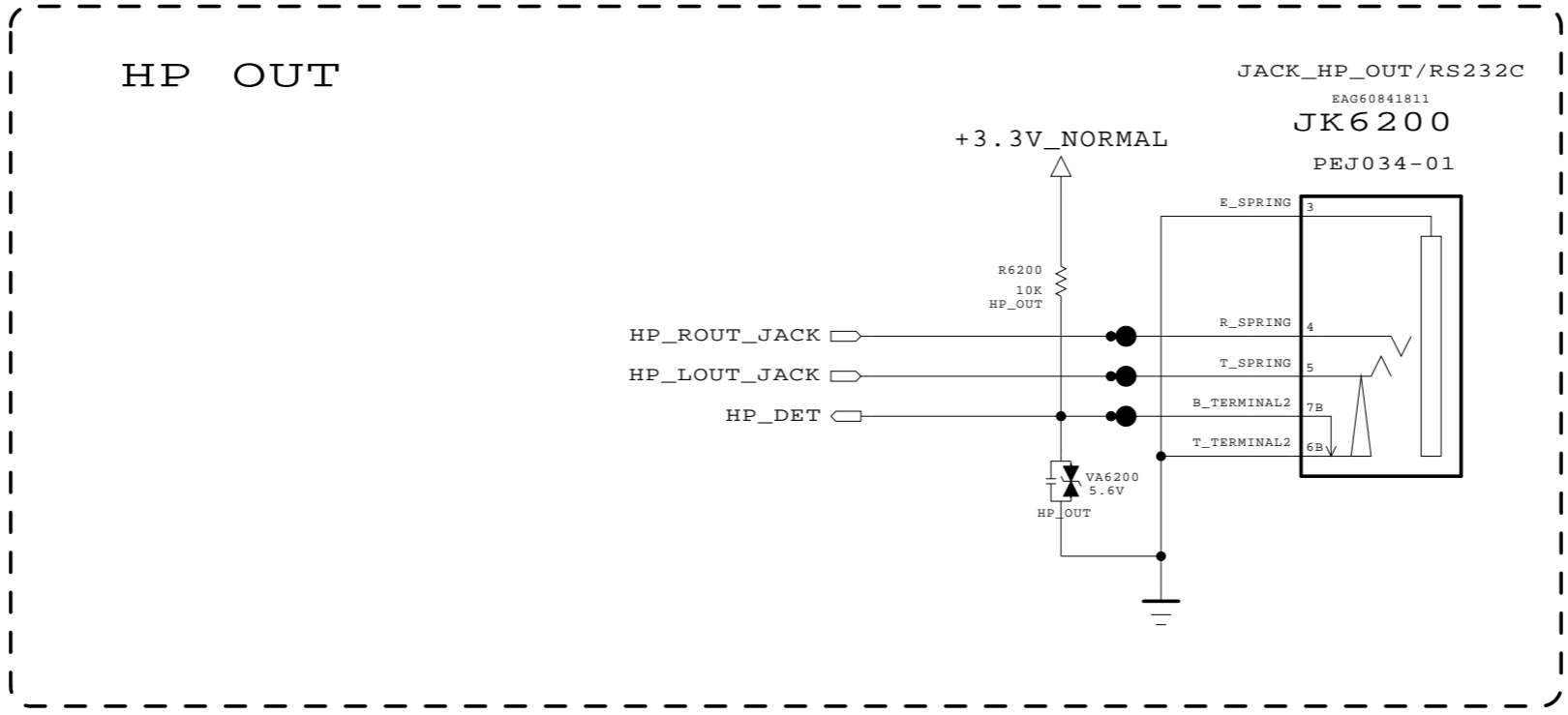

THE SYMBOL MARK OF THIS SCHEMATIC DIAGRAM INCORPORATES SPECIAL FEATURES IMPORTANT FOR PROTECTION FROM X-RADIATION. FIRE AND ELECTRICAL SHOCK HAZARDS, WHEN SERVICING IF IS ESSENTIAL THAT ONLY MANUFACTURES SPECIFIED PARTS BE USED FOR THE CRITICAL COMPONENTS IN THE SYMBOL MARK OF THE SCHEMATIC.

SECRET
LGElectronics



MODEL		DATE	15/06/13
BLOCK	HP JACK	SHEET	23 / 73

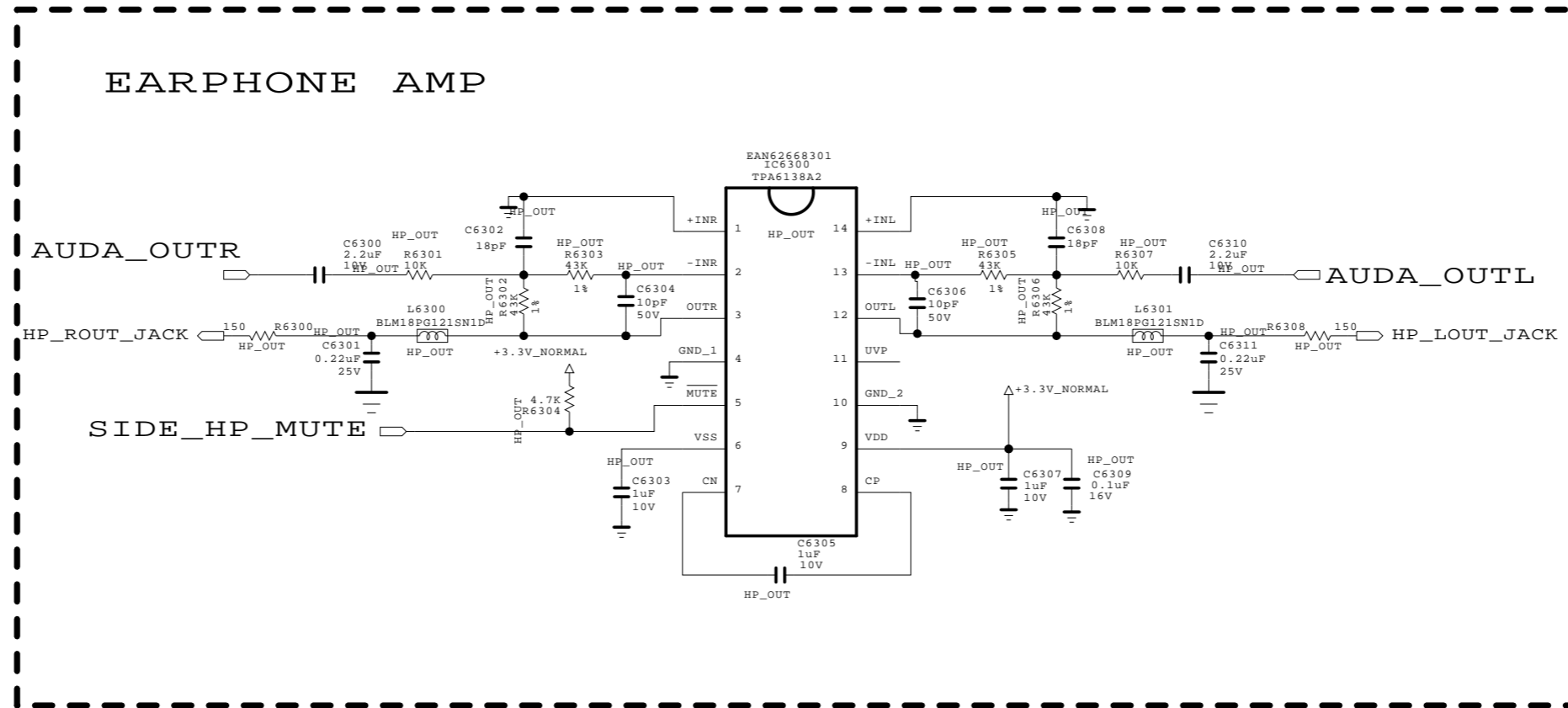

THE SYMBOL MARK OF THIS SCHEMATIC DIAGRAM INCORPORATES SPECIAL FEATURES IMPORTANT FOR PROTECTION FROM X-RADIATION. FIRE AND ELECTRICAL SHOCK HAZARDS, WHEN SERVICING IF IS ESSENTIAL THAT ONLY MANUFACTURERS SPECIFIED PARTS BE USED FOR THE CRITICAL COMPONENTS IN THE SYMBOL MARK OF THE SCHEMATIC.

SECRET
LGElectronics



MODEL	M16	DATE	2015.02.09
BLOCK	HEADPHONE AMP	SHEET	23 / 73

063.sht

B-CAS (SMART CARD) INTERFACE

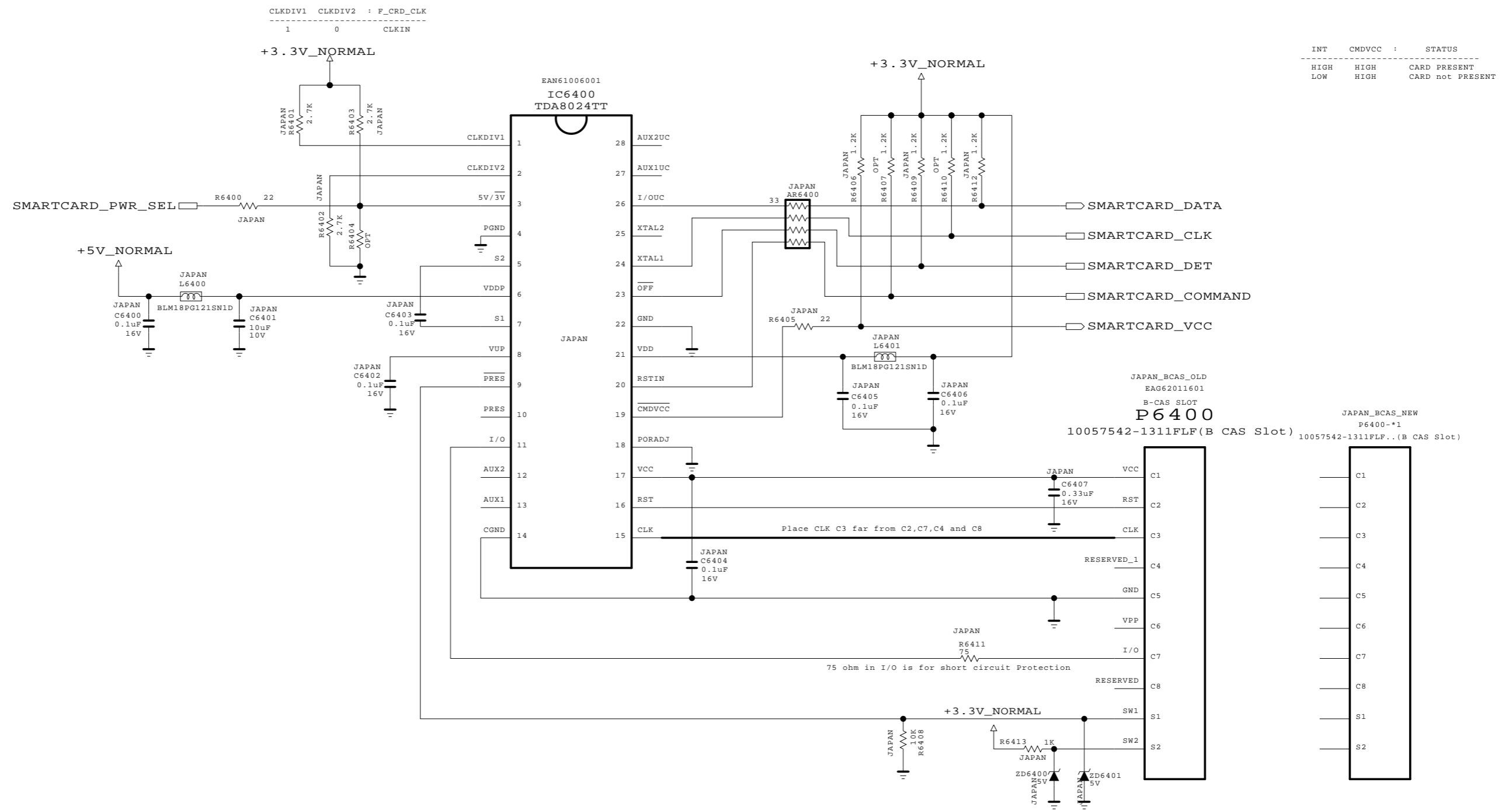

THE SYMBOL MARK OF THIS SCHEMATIC DIAGRAM INCORPORATES SPECIAL FEATURES IMPORTANT FOR PROTECTION FROM X-RADIATION. FIRE AND ELECTRICAL SHOCK HAZARDS, WHEN SERVICING IF IS ESSENTIAL THAT ONLY MANUFACTURES SPECIFIED PARTS BE USED FOR THE CRITICAL COMPONENTS IN THE SYMBOL MARK OF THE SCHEMATIC.

SECRET	LG ELECTRONICS
LGElectronics	

MODEL	M16	DATE	2015.02.09
BLOCK	JAPAN B-CAS	SHEET	23 / 26

064.sht

● FE_DEMOD1_TS_ERROR
 ● FE_DEMOD2_TS_ERROR

1. should be guarded by ground
2. No via on both of them
3. Signal Width >= 12mils
Signal to Signal Width = 12mils
Ground Width >= 24mils

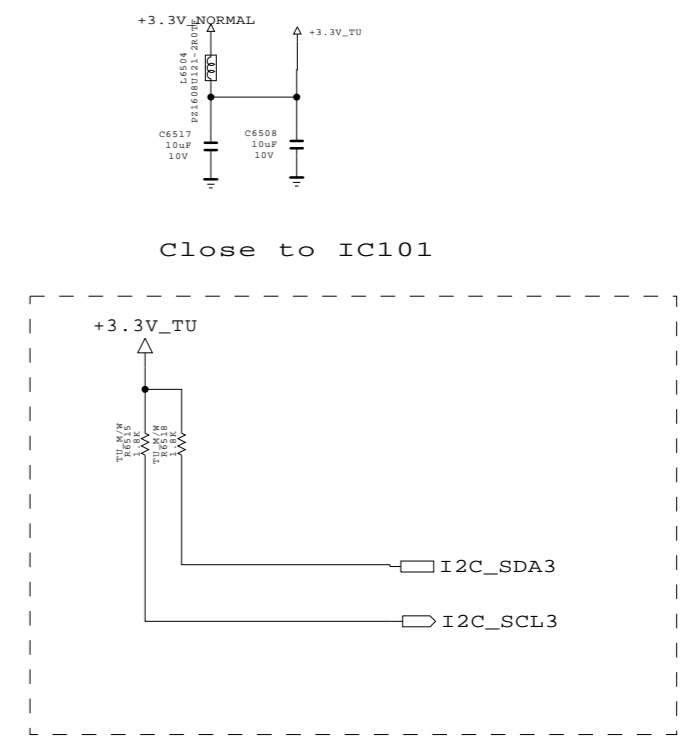
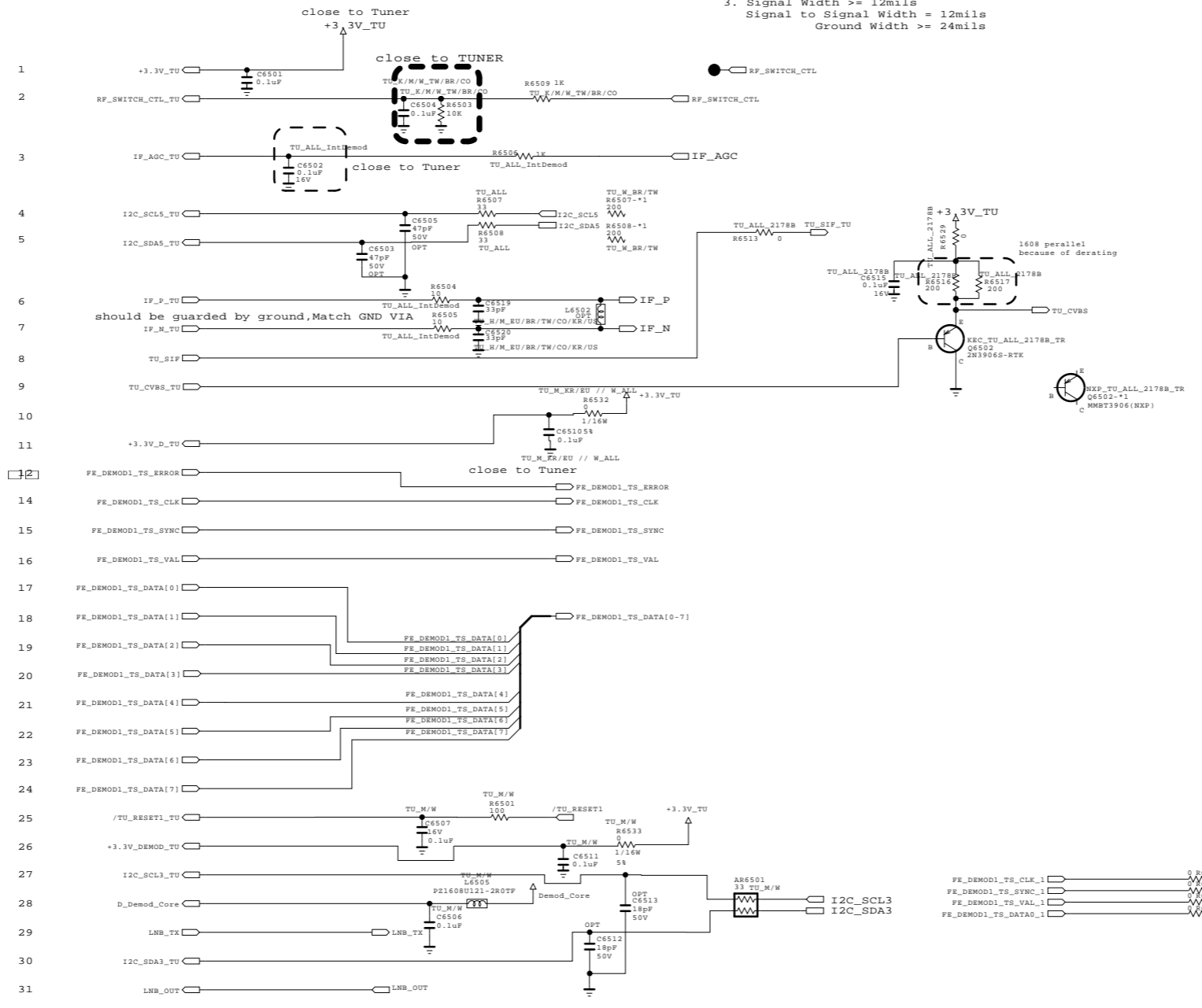

Close to Tuner

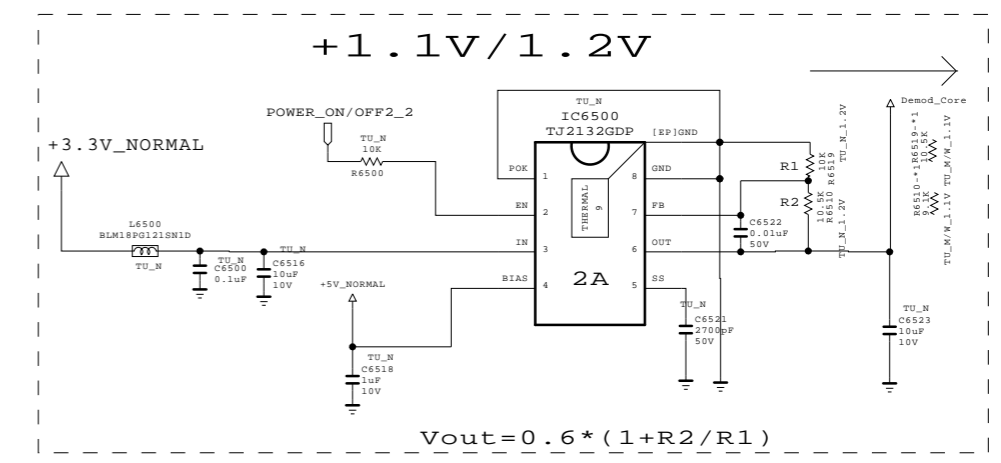

Global F/E Option Name
 1. TU
 2. Tuner Name = TDJ'H', TDj'M'...
 3. Country Name = KR,US,BR,EU ...

Example of Option name
 TU_ALL_IntDemod = All Tuner type for Internal demod
 TU_M/W = apply TDSM&TDSW Type Tuner

14' Tuner Type for Global
 TDJ'H'-G101D : Half NIM for EU,AJJA
 TDJ'H'-H101F : Half NIM for US, KR
 TDJ'K'-T101F : Half NIM for TW
 TDJ'M'-C301D,F : FULL NIM for China
 TDJ'M'-B101F : Brazil NIM with Isolater Type
 TDJ'M'-K101F : Colombia NIM
 TDJ'M'-G101D,G105D,G151D : EU Combo&Full NIM
 TDJ'M'-H101F,H151F : Korea PIP tuner
 TDJ'W'-A151D : AJJA T2 PIP

THE Δ SYMBOL MARK OF THIS SCHEMATIC DIAGRAM INCORPORATES SPECIAL FEATURES IMPORTANT FOR PROTECTION FROM X-RADIATION, FIRE AND ELECTRICAL SHOCK HAZARDS, WHEN SERVICING IF IS ESSENTIAL THAT ONLY MANUFACTURERS SPECIFIED PARTS BE USED FOR THE CRITICAL COMPONENTS IN THE Δ SYMBOL MARK OF THE SCHEMATIC.

SECRET
 LGElectronics



MODEL	TUNER	DATE	2015.04.20
BLOCK		SHEET	65

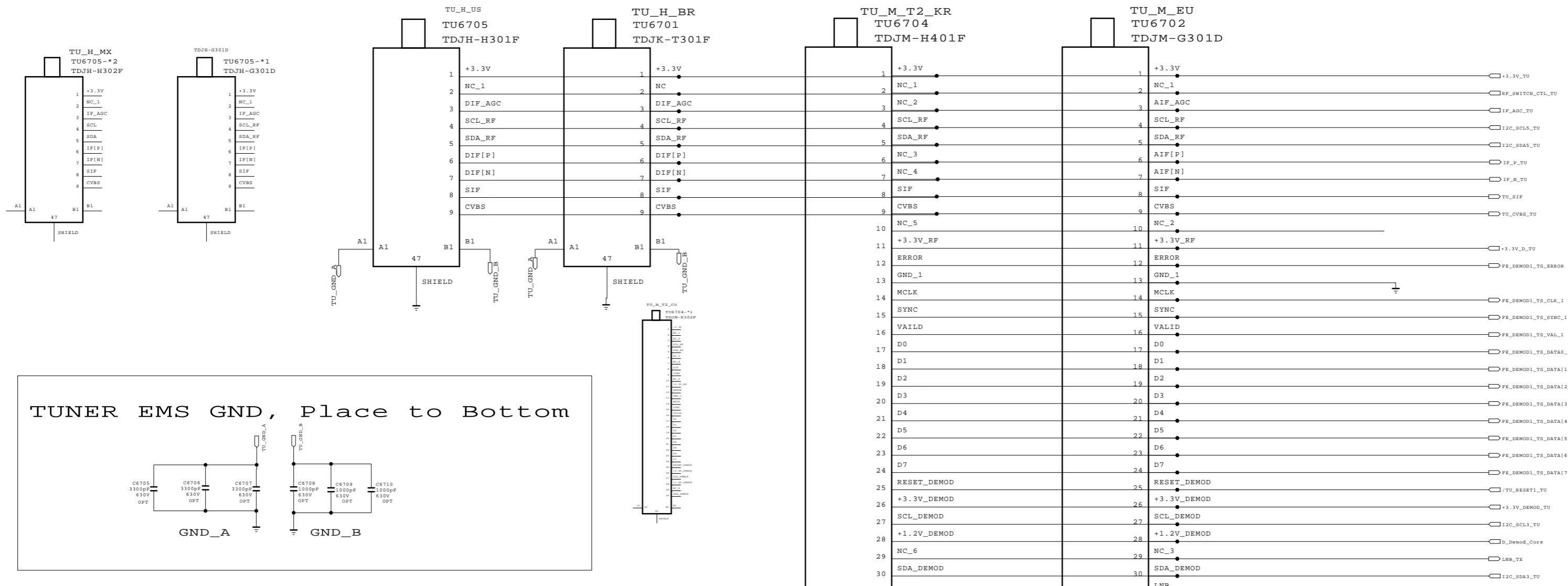

TUNER EMS GND, Place to Bottom

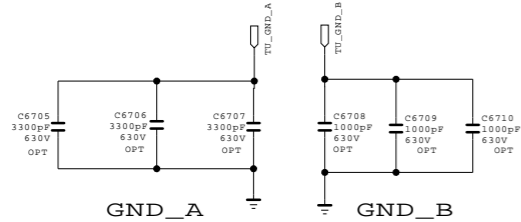

TUNER EMS GND SEPERATION, Top

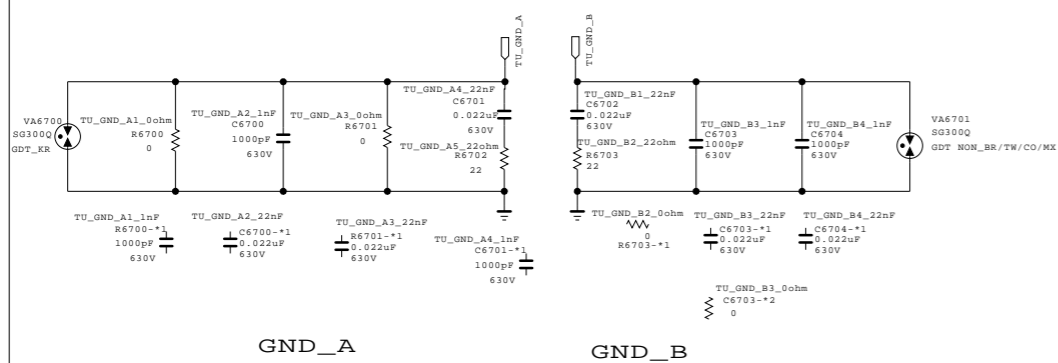

TU_GND_A	EU/CIS	AJJA	TW/COL	CN/RK	KR	North.AM	BR	JP
GND_A_1			0 ohm				0 ohm	
GND_A_2			X				X	
GND_A_3			0 ohm				0 ohm	
GND_A_4			X				X	
GND_A_5			X				X	

TU_GND_B	EU/CIS	AJJA	TW/COL	CN/RK	KR	North.AM	BR	JP
GND_B_1			X				X	
GND_B_2			X				X	
GND_B_3			0 ohm				0 ohm	
GND_B_4			X				X	

THE Δ SYMBOL MARK OF THIS SCHEMATIC DIAGRAM INCORPORATES SPECIAL FEATURES IMPORTANT FOR PROTECTION FROM X-RADIATION. FIRE AND ELECTRICAL SHOCK HAZARDS, WHEN SERVICING IF IS ESSENTIAL THAT ONLY MANUFACTURERS SPECIFIED PARTS BE USED FOR THE CRITICAL COMPONENTS IN THE Δ SYMBOL MARK OF THE SCHEMATIC.

SECRET
LGElectronics

LG ELECTRONICS

MODEL	TU_SYMBOL	DATE	2012.09.14
BLOCK		SHEET	73

DVB-S2 LNB Part Allegro

(Option:LNB)

Input trace widths should be sized to conduct at least 3A
 Output trace widths should be sized to conduct at least 2A

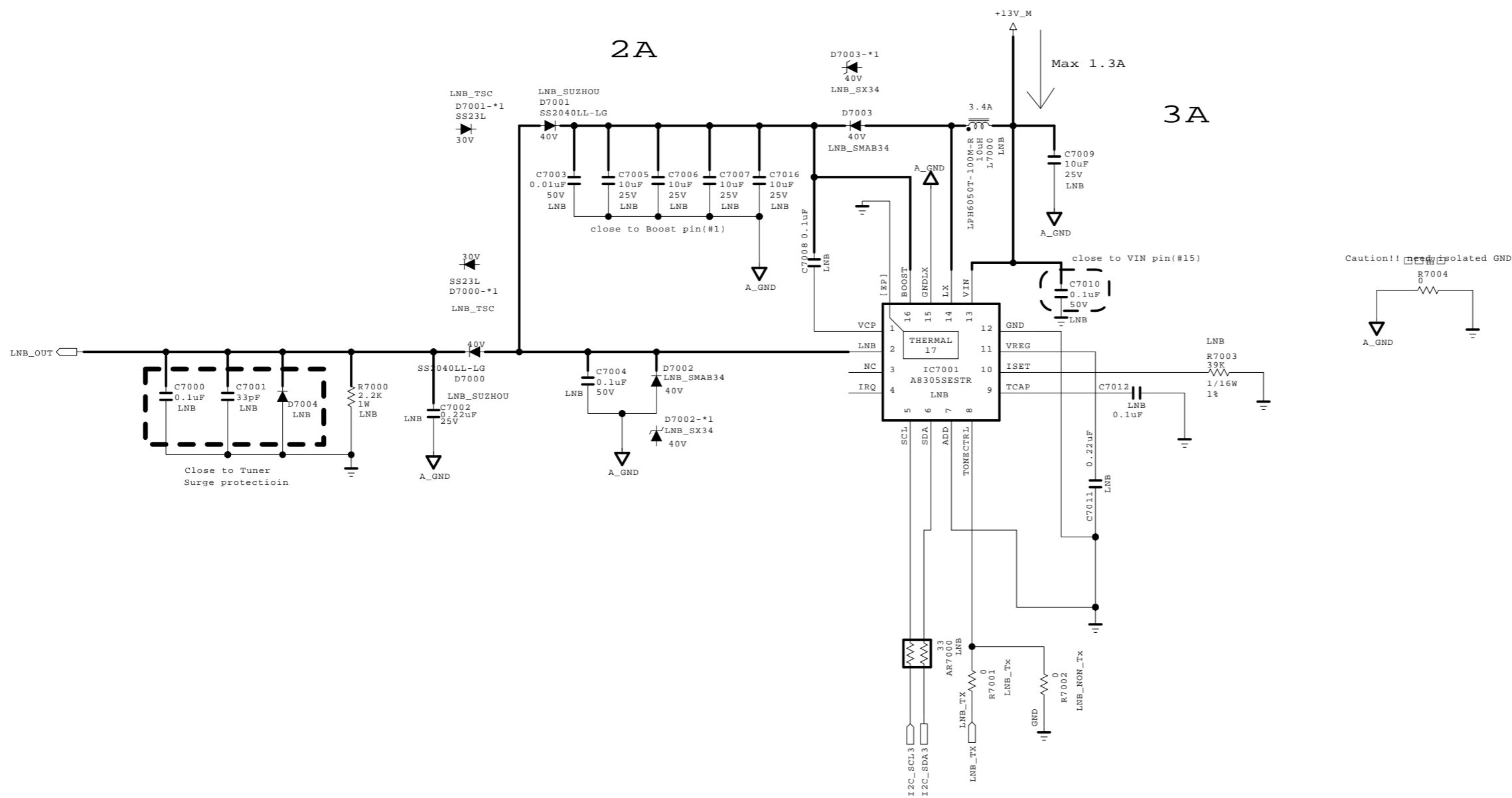



THE SYMBOL MARK OF THIS SCHEMATIC DIAGRAM INCORPORATES SPECIAL FEATURES IMPORTANT FOR PROTECTION FROM X-RADIATION. FIRE AND ELECTRICAL SHOCK HAZARDS, WHEN SERVICING IF IS ESSENTIAL THAT ONLY MANUFACTURES SPECIFIED PARTS BE USED FOR THE CRITICAL COMPONENTS IN THE SYMBOL MARK OF THE SCHEMATIC.

SECRET	LG ELECTRONICS
LGElectronics	

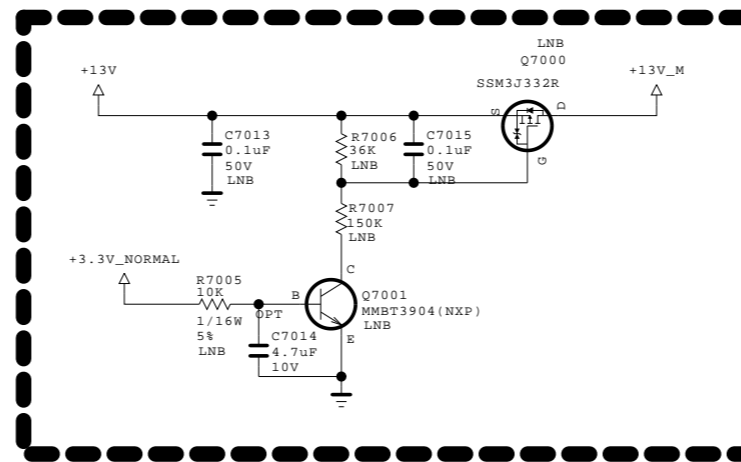
MODEL	M16	DATE	2015.06.05
BLOCK	LNB	SHEET	70 / 100



THE  SYMBOL MARK OF THIS SCHEMATIC DIAGRAM INCORPORATES SPECIAL FEATURES IMPORTANT FOR PROTECTION FROM X-RADIATION. FIRE AND ELECTRICAL SHOCK HAZARDS, WHEN SERVICING IF IS ESSENTIAL THAT ONLY MANUFACTURERS SPECIFIED PARTS BE USED FOR THE CRITICAL COMPONENTS IN THE  SYMBOL MARK OF THE SCHEMATIC.

SECRET
LGElectronics



MODEL	M16	DATE	2015.06.05
BLOCK	LNB	SHEET	70 / 100

RS-232C Control INTERFACE

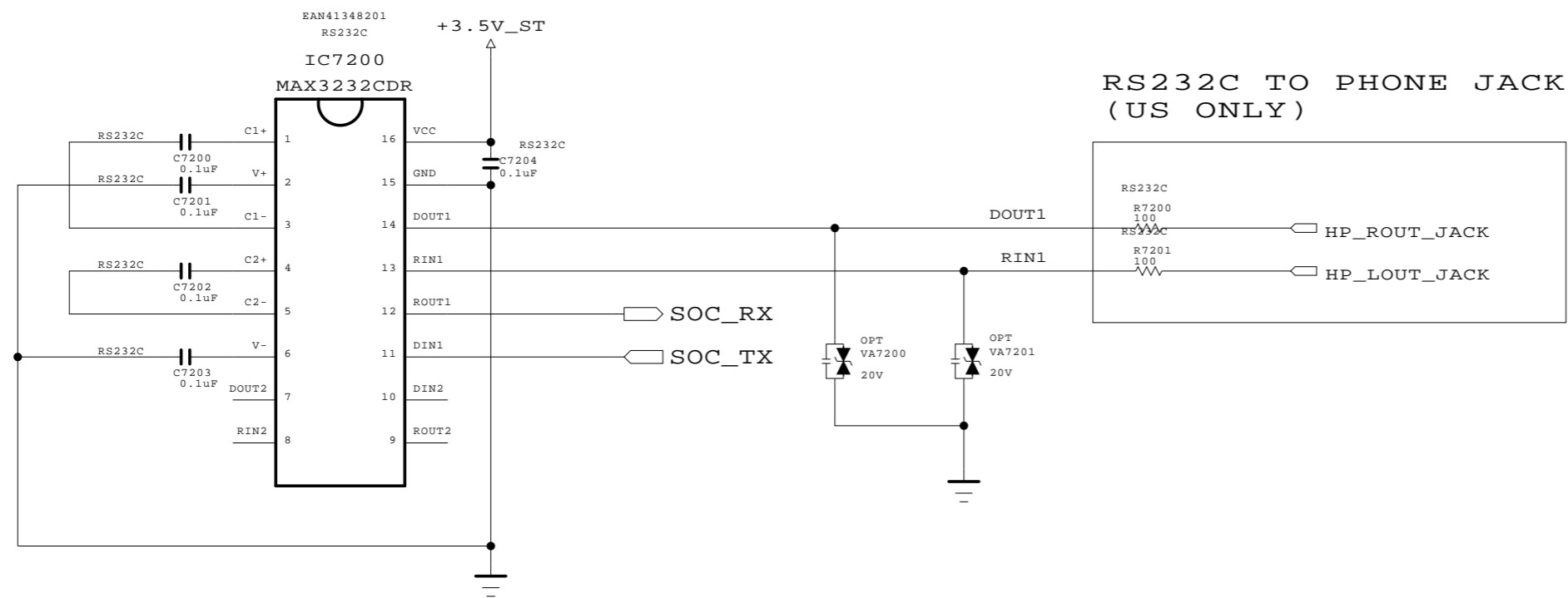

THE SYMBOL MARK OF THIS SCHEMATIC DIAGRAM INCORPORATES SPECIAL FEATURES IMPORTANT FOR PROTECTION FROM X-RADIATION. FIRE AND ELECTRICAL SHOCK HAZARDS, WHEN SERVICING IT IS ESSENTIAL THAT ONLY MANUFACTURERS SPECIFIED PARTS BE USED FOR THE CRITICAL COMPONENTS IN THE SYMBOL MARK OF THE SCHEMATIC.

SECRET
LGElectronics



MODEL		DATE	15/06/13
BLOCK	RS232C	SHEET	73

Non-Reverse

[51P Vx1
output wafer]

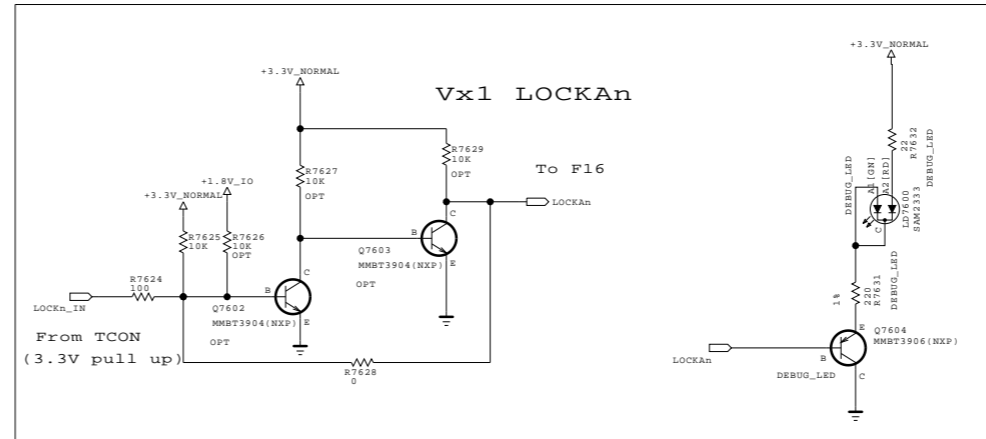
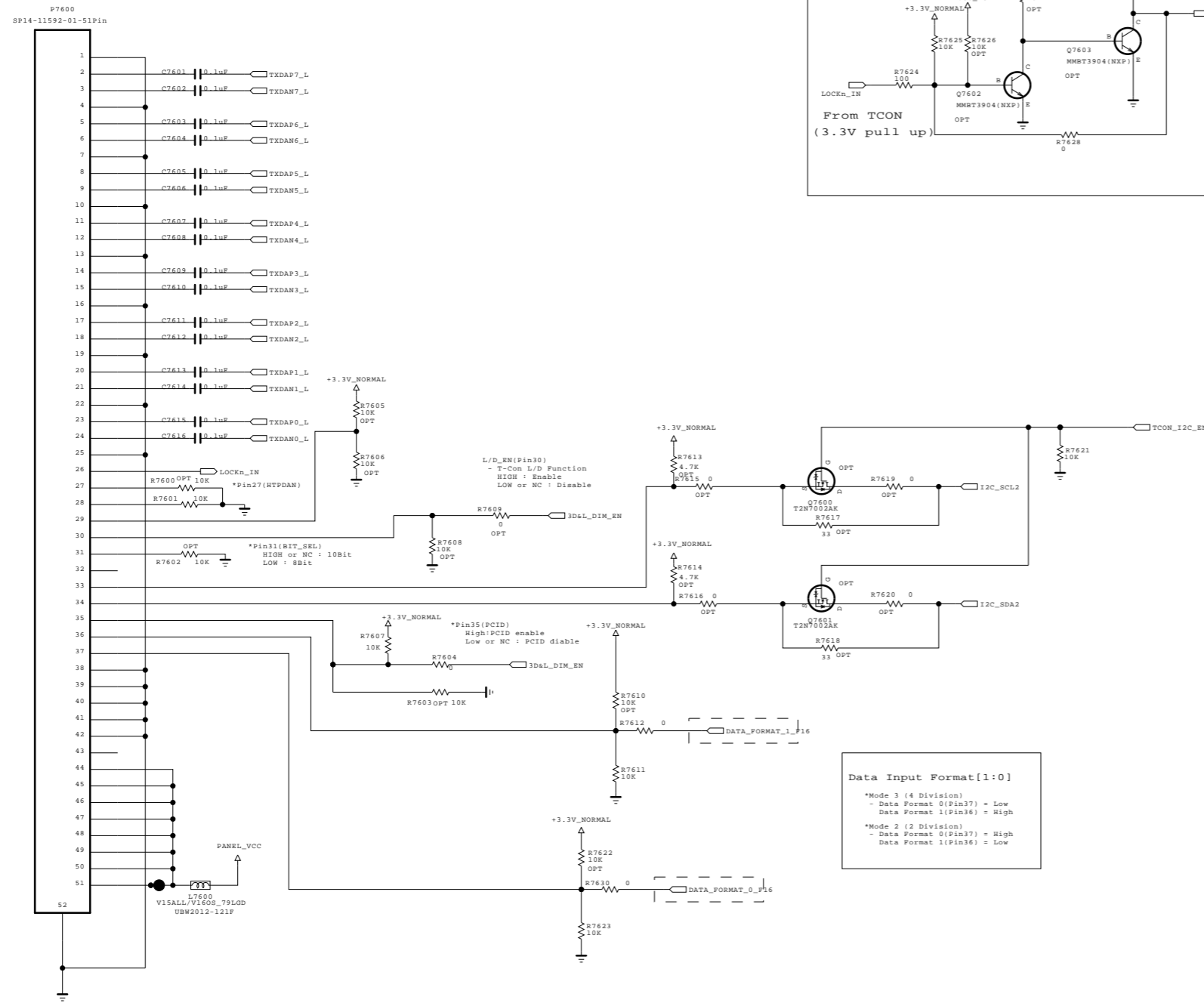

[41P Vx1
output wafer]

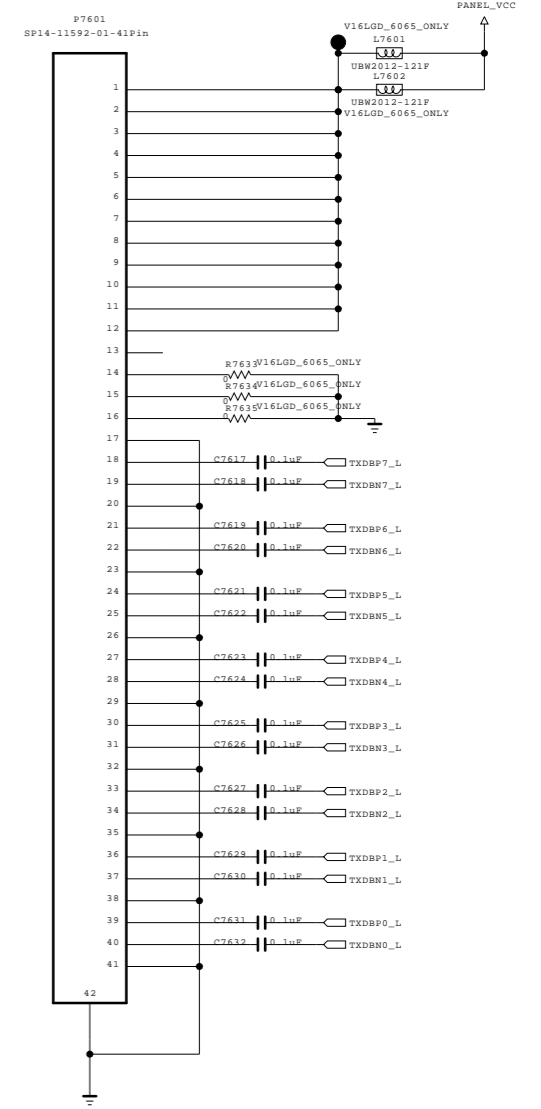

THE Δ SYMBOL MARK OF THIS SCHEMATIC DIAGRAM INCORPORATES SPECIAL FEATURES IMPORTANT FOR PROTECTION FROM X-RADIATION. FIRE AND ELECTRICAL SHOCK HAZARDS, WHEN SERVICING IS ESSENTIAL THAT ONLY MANUFACTURERS SPECIFIED PARTS BE USED FOR THE CRITICAL COMPONENTS IN THE Δ SYMBOL MARK OF THE SCHEMATIC.

SECRET
LGElectronics



MODEL	F16	DATE	2015.6.13
BLOCK	Output wafer	SHEET	76 / 100

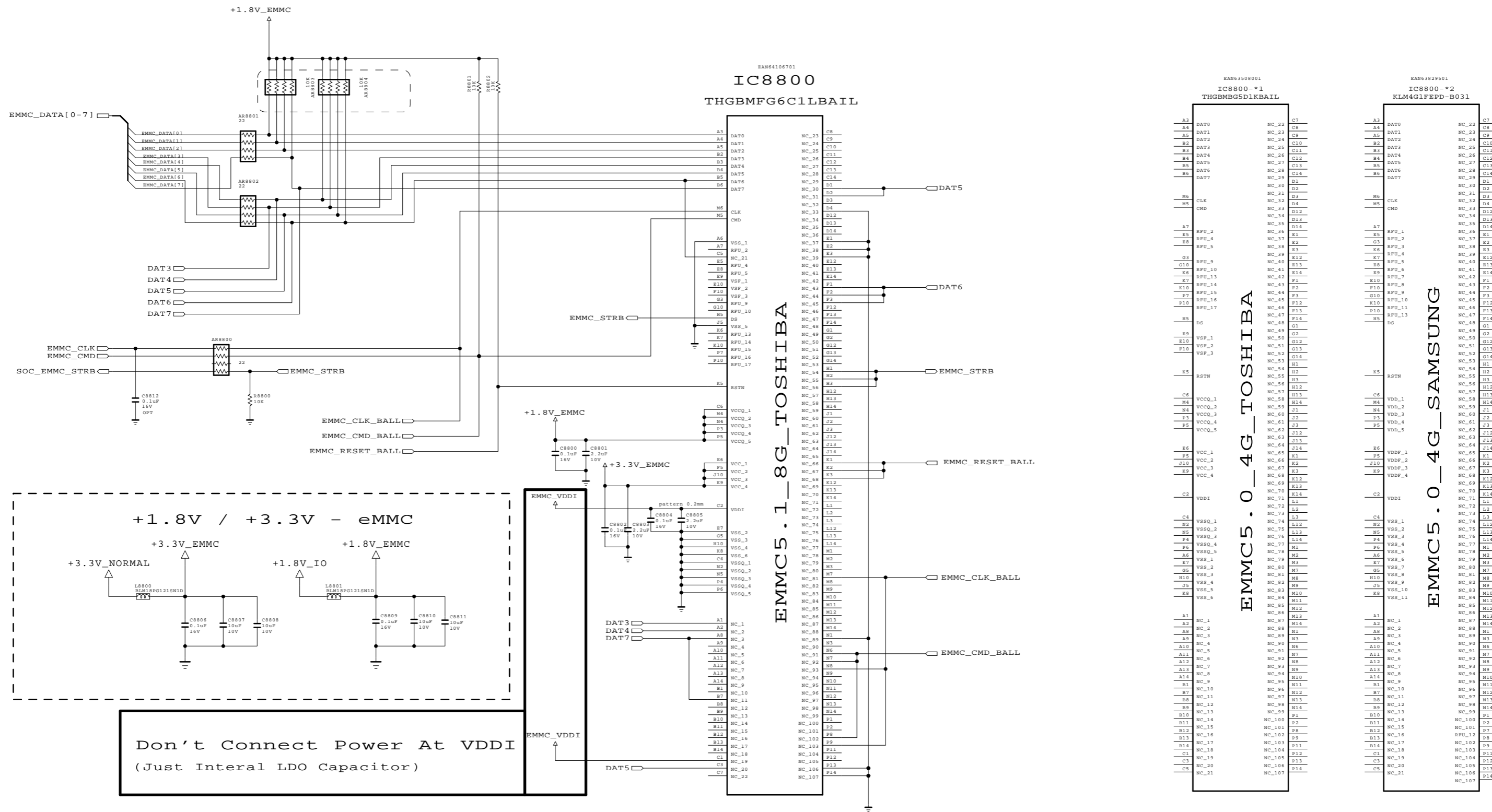

THE Δ SYMBOL MARK OF THIS SCHEMATIC DIAGRAM INCORPORATES SPECIAL FEATURES IMPORTANT FOR PROTECTION FROM X-RADIATION. FIRE AND ELECTRICAL SHOCK HAZARDS, WHEN SERVICING IF IS ESSENTIAL THAT ONLY MANUFACTURERS SPECIFIED PARTS BE USED FOR THE CRITICAL COMPONENTS IN THE Δ SYMBOL MARK OF THE SCHEMATIC.

SECRET
LGElectronics



MODEL	M16	DATE	2015.02.09
BLOCK	eMMC 5.0	SHEET	26 / 26

081.sht

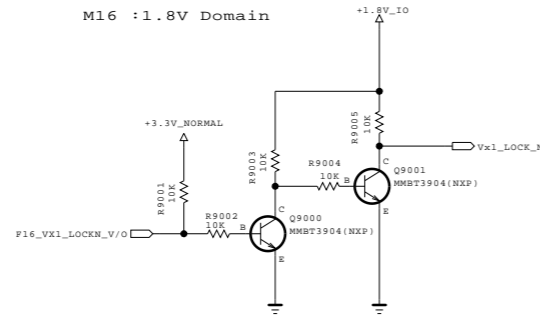
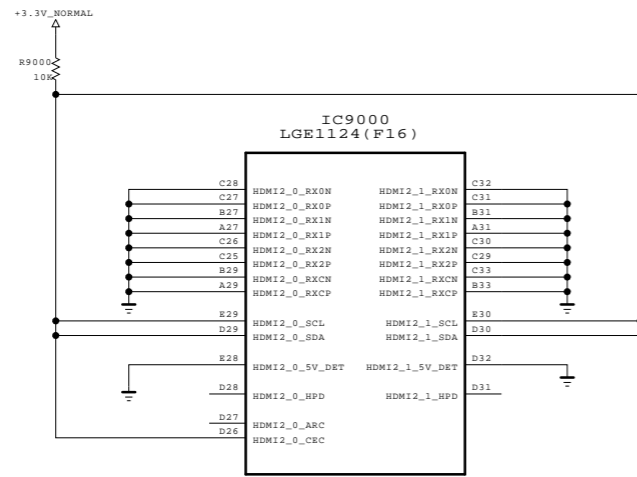

Vx1 Rx Vide
(8 lane)
From M16

Vx1 Rx OSD
(2 lane)
From M16

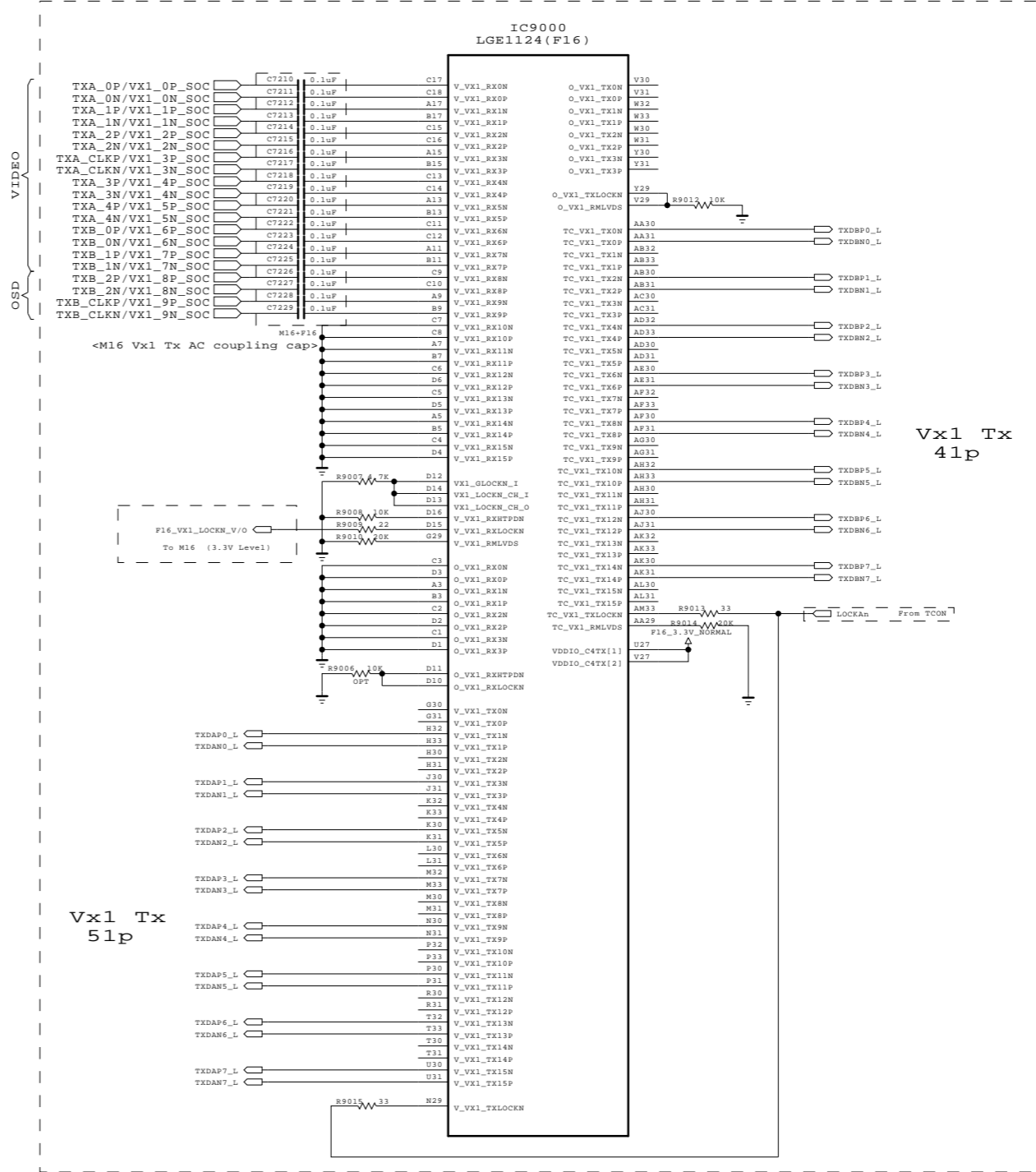

Vx1 Tx
41p

Vx1 Tx
51p

THE Δ SYMBOL MARK OF THIS SCHEMATIC DIAGRAM INCORPORATES SPECIAL FEATURES IMPORTANT FOR PROTECTION FROM X-RADIATION, FIRE AND ELECTRICAL SHOCK HAZARDS, WHEN SERVICING IT IS ESSENTIAL THAT ONLY MANUFACTURERS SPECIFIED PARTS BE USED FOR THE CRITICAL COMPONENTS IN THE Δ SYMBOL MARK OF THE SCHEMATIC.

SECRET
LGElectronics



MODEL		DATE	2015.4.27
BLOCK	Vx1, HDMI IF	SHEET	/

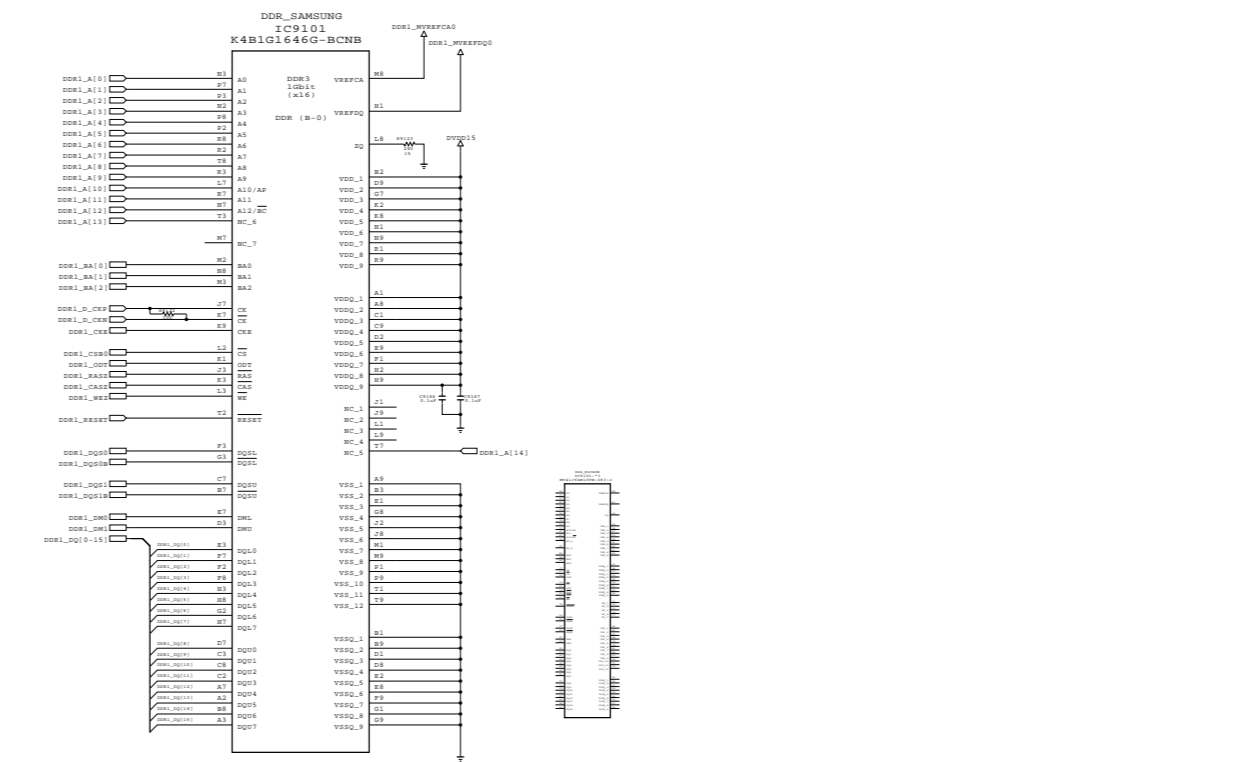
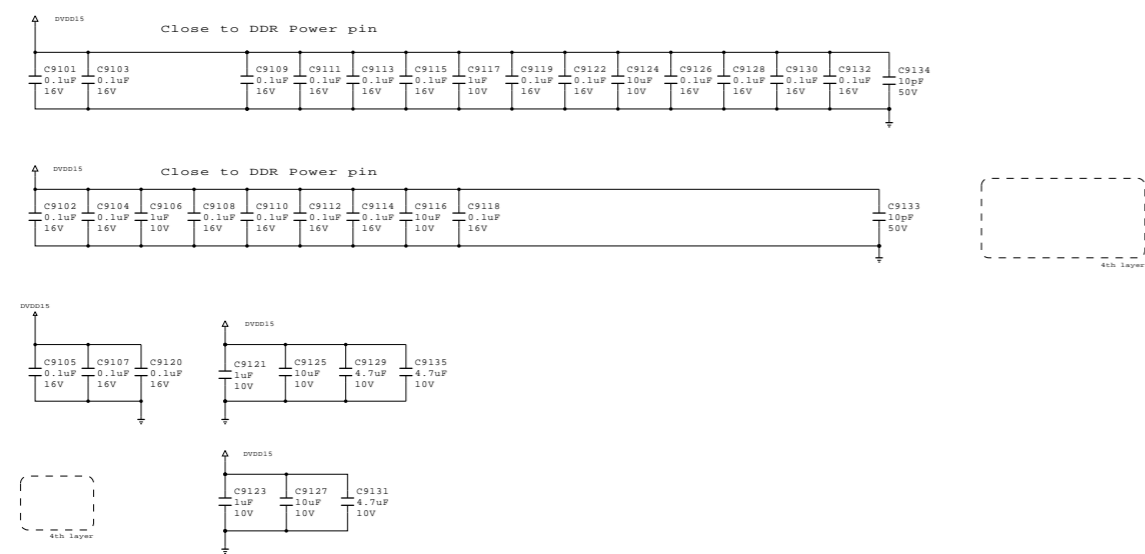
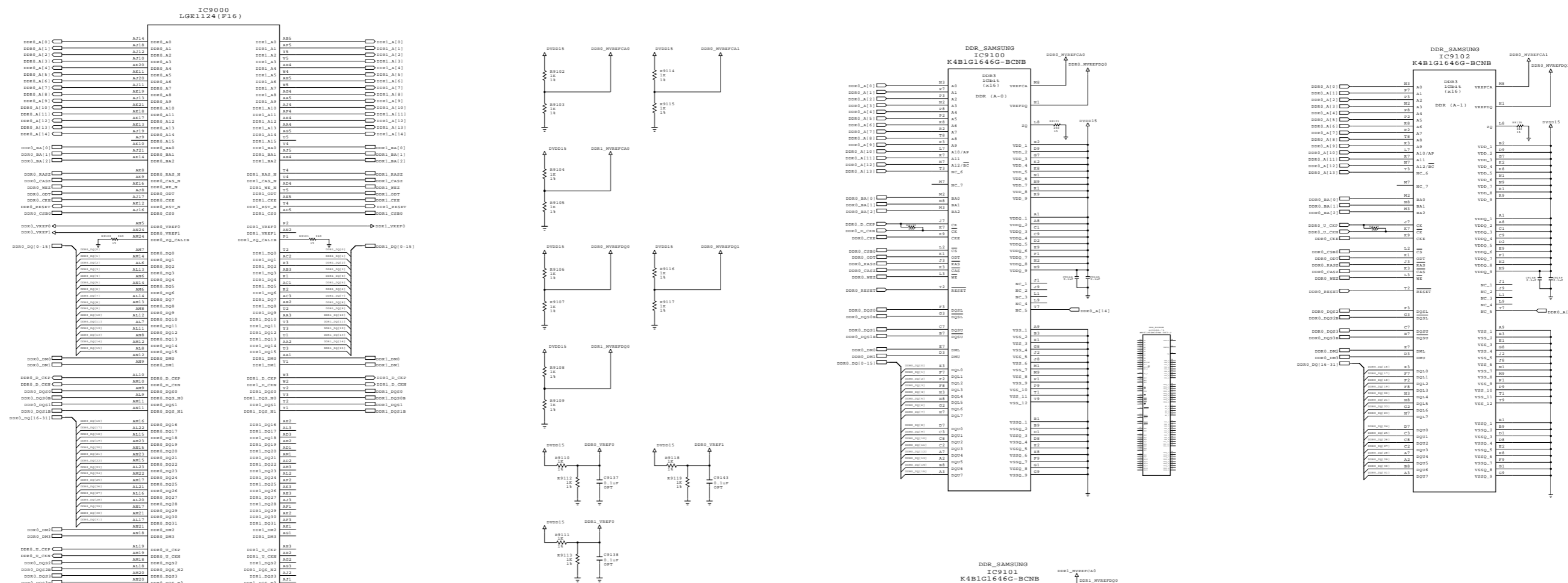

THE SYMBOL MARK OF THIS SCHEMATIC DIAGRAM INCORPORATES SPECIAL FEATURES IMPORTANT FOR PROTECTION FROM X-RADIATION. FIRE AND ELECTRICAL SHOCK HAZARDS. WHEN SERVICING IF IS ESSENTIAL THAT ONLY MANUFACTURER'S SPECIFIED PARTS BE USED FOR THE CRITICAL COMPONENTS IN THE Δ SYMBOL MARK OF THE SCHEMATIC.

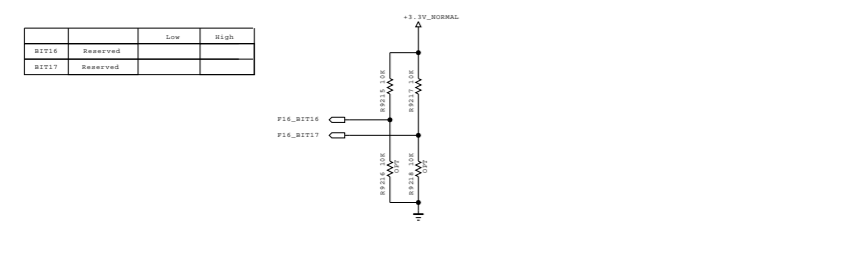
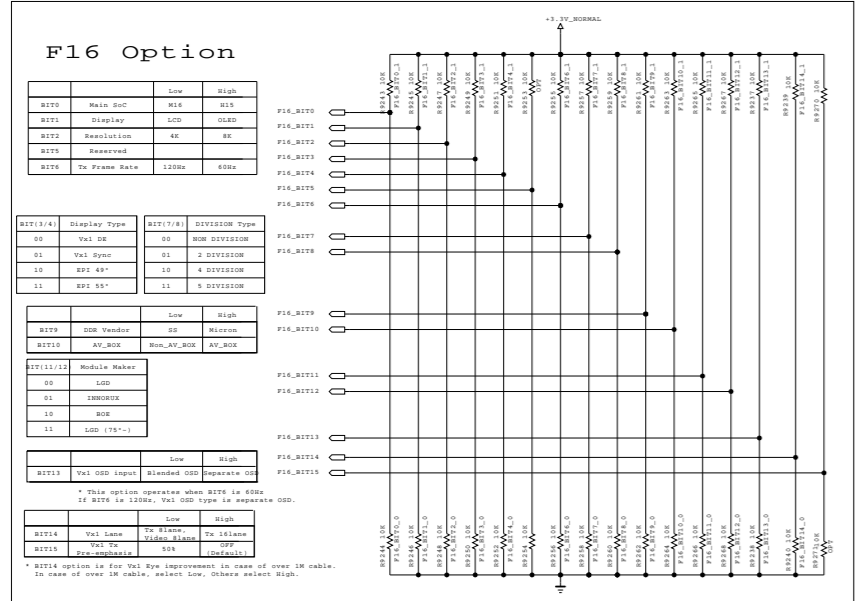
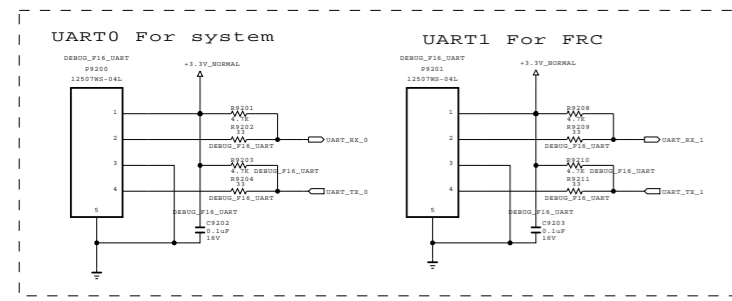
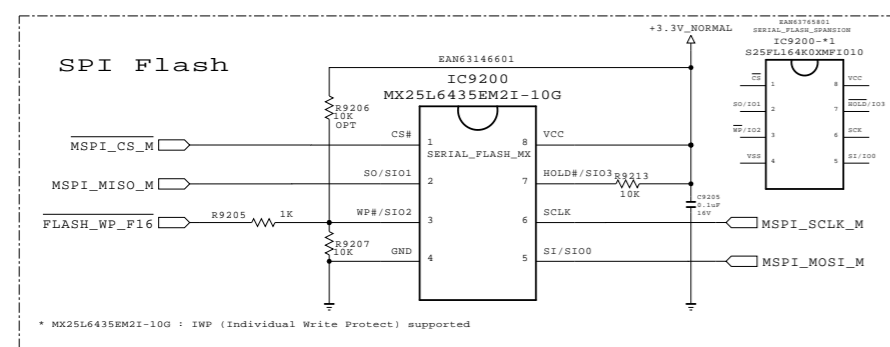
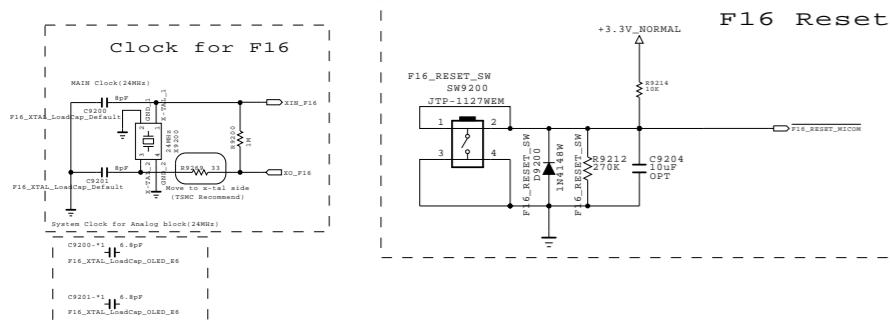

THE Δ SYMBOL MARK OF THIS SCHEMATIC DIAGRAM INCORPORATES SPECIAL FEATURES IMPORTANT FOR PROTECTION FROM X-RADIATION. FIRE AND ELECTRICAL SHOCK HAZARDS, WHEN SERVICING IF IS ESSENTIAL THAT ONLY MANUFACTURERS SPECIFIED PARTS BE USED FOR THE CRITICAL COMPONENTS IN THE Δ SYMBOL MARK OF THE SCHEMATIC.

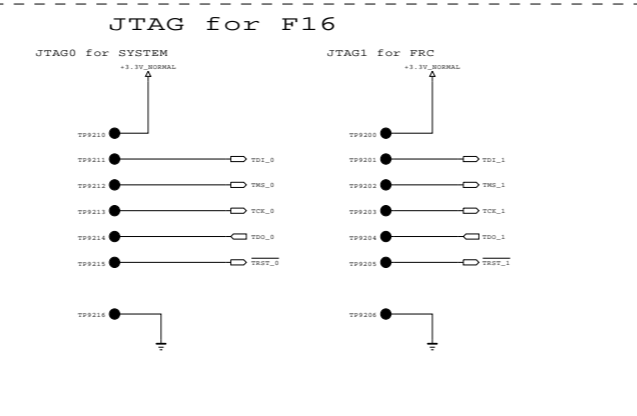

IC9000 LGE1124 (F16)

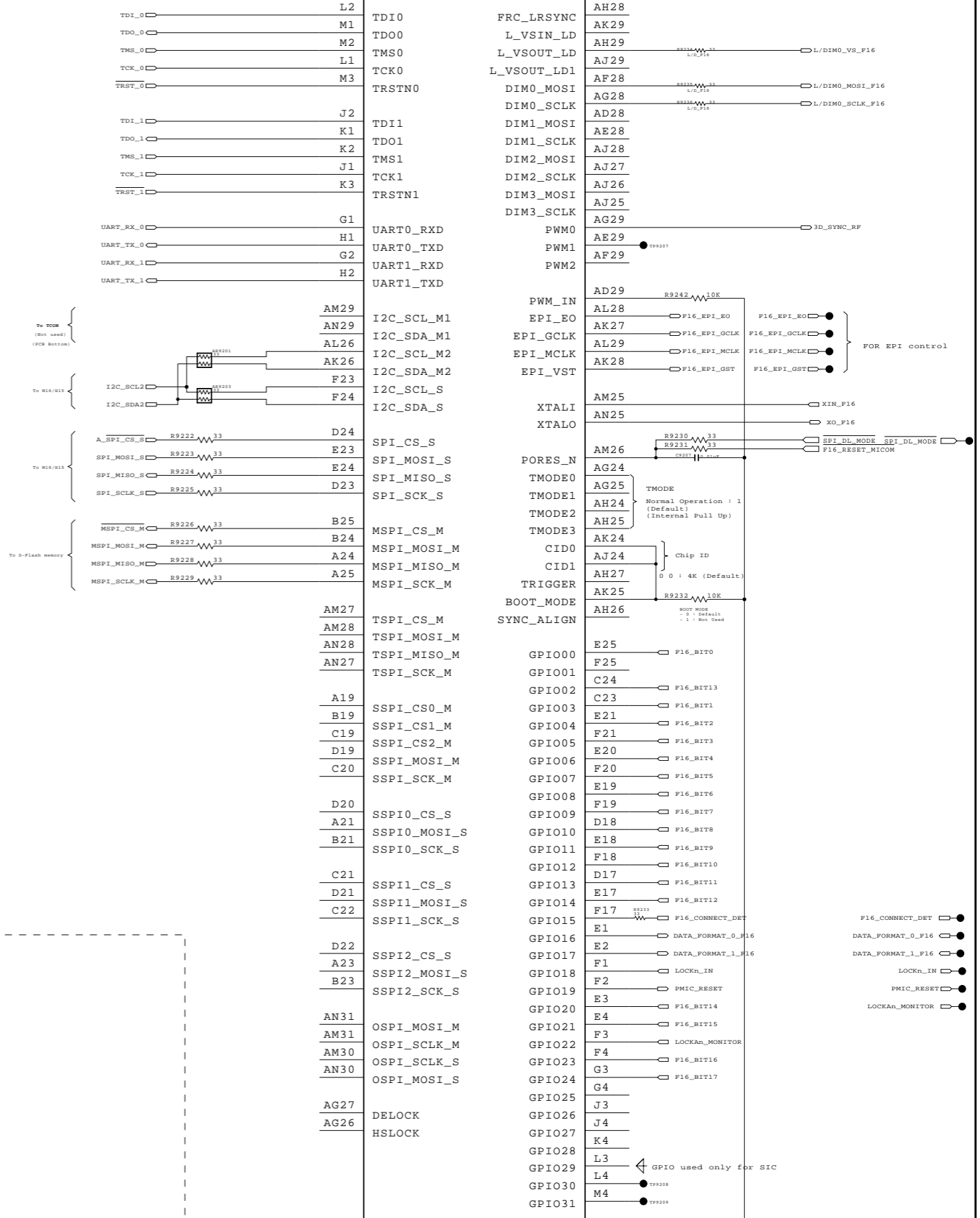

SECRET
LGElectronics



MODEL	M16	DATE	2015.11.23
BLOCK	F16_SPI, UART, GPIO	SHEET	92 / 99

+0.9V F16 Core

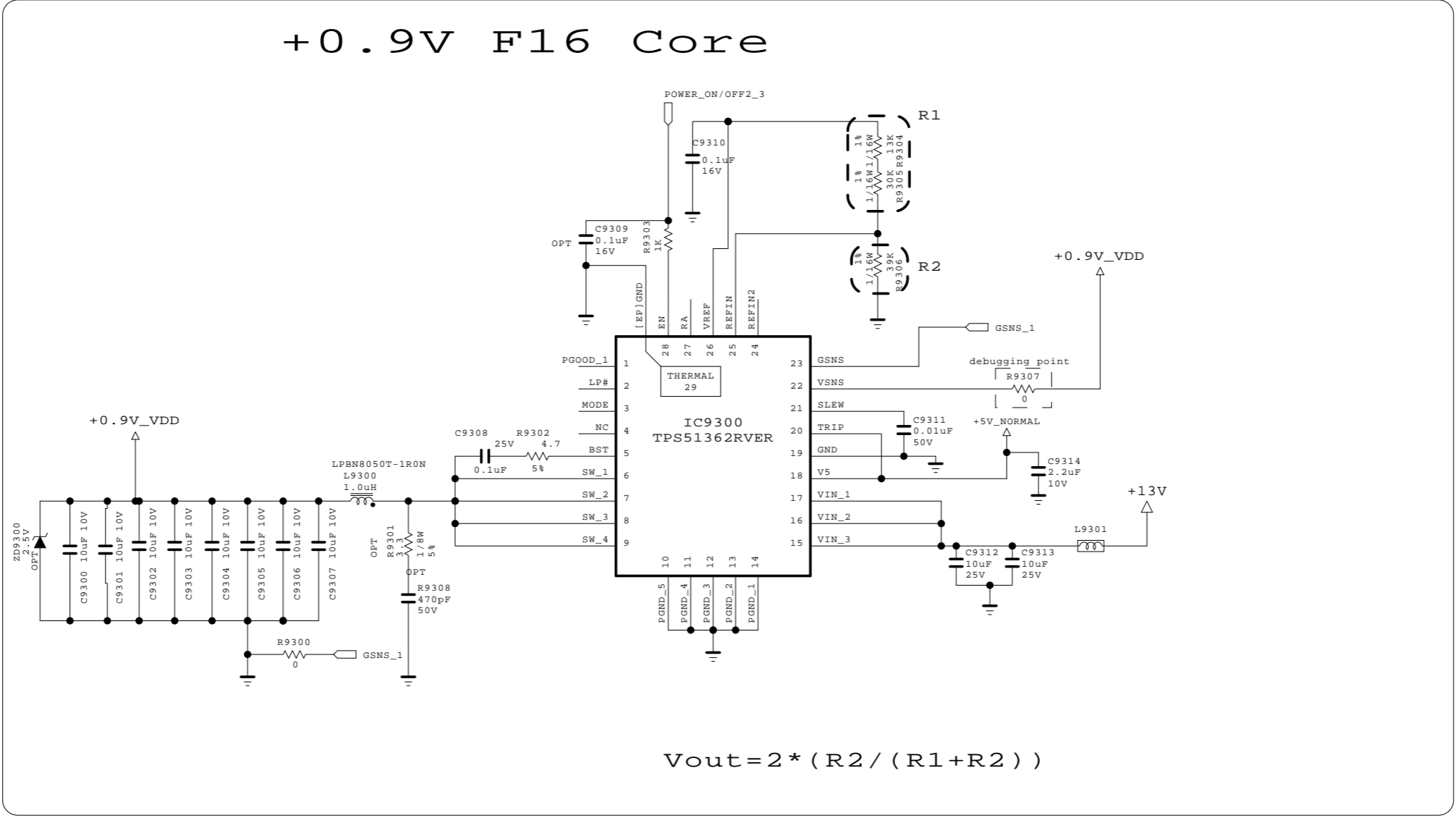

THE SYMBOL MARK OF THIS SCHEMATIC DIAGRAM INCORPORATES SPECIAL FEATURES IMPORTANT FOR PROTECTION FROM X-RADIATION. FIRE AND ELECTRICAL SHOCK HAZARDS, WHEN SERVICING IF IS ESSENTIAL THAT ONLY MANUFACTURES SPECIFIED PARTS BE USED FOR THE CRITICAL COMPONENTS IN THE SYMBOL MARK OF THE SCHEMATIC.

SECRET
LGElectronics



MODEL	F16	DATE	2015.6.10
BLOCK	F16_0.9V Core	SHEET	93 / 100

+1.5V F16 DDR

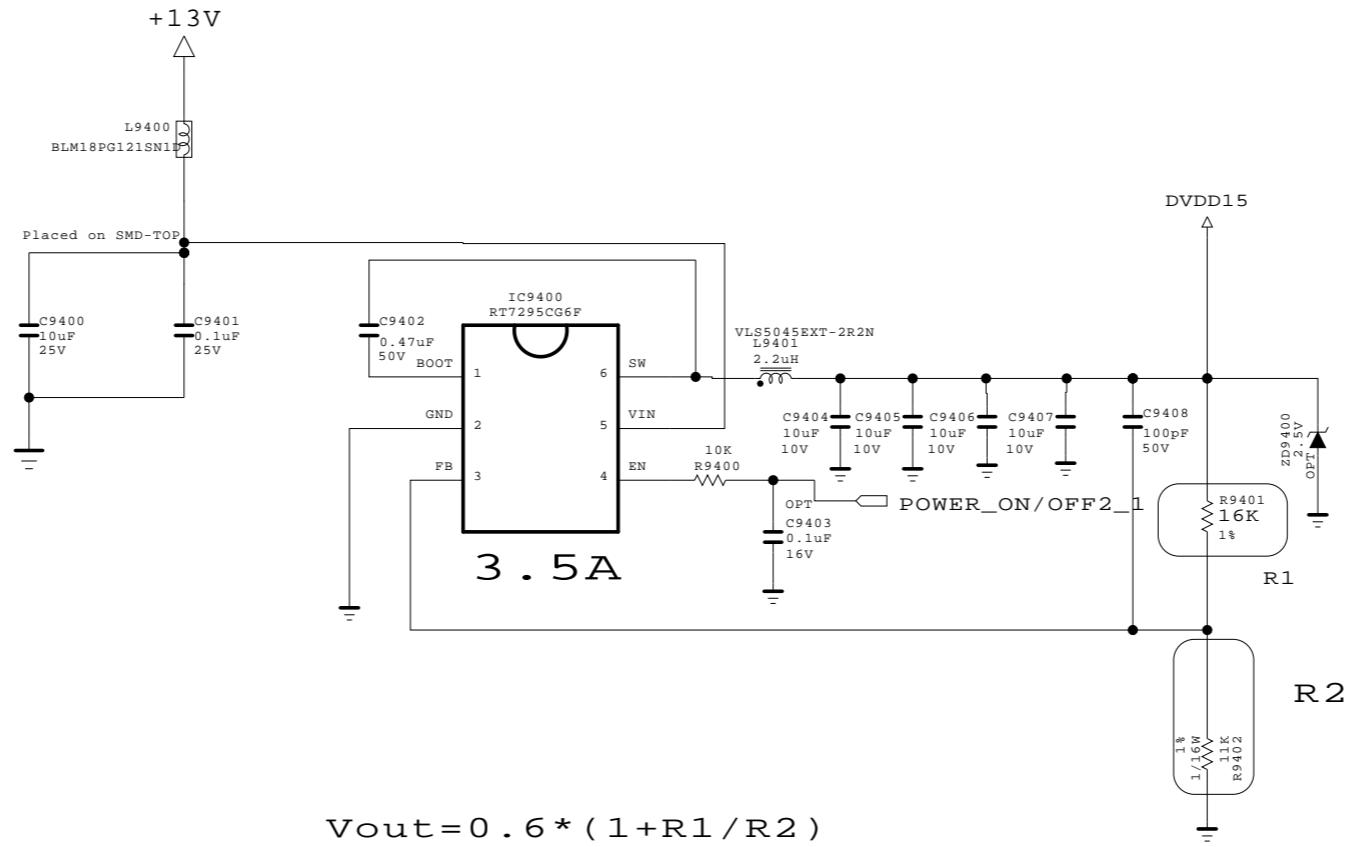

THE SYMBOL MARK OF THIS SCHEMATIC DIAGRAM INCORPORATES SPECIAL FEATURES IMPORTANT FOR PROTECTION FROM X-RADIATION. FIRE AND ELECTRICAL SHOCK HAZARDS, WHEN SERVICING IF IS ESSENTIAL THAT ONLY MANUFACTURERS SPECIFIED PARTS BE USED FOR THE CRITICAL COMPONENTS IN THE SYMBOL MARK OF THE SCHEMATIC.

SECRET
LGElectronics



MODEL	F16	DATE	2015.6.10
BLOCK	F16 1.5V_DDR	SHEET	94 / 100

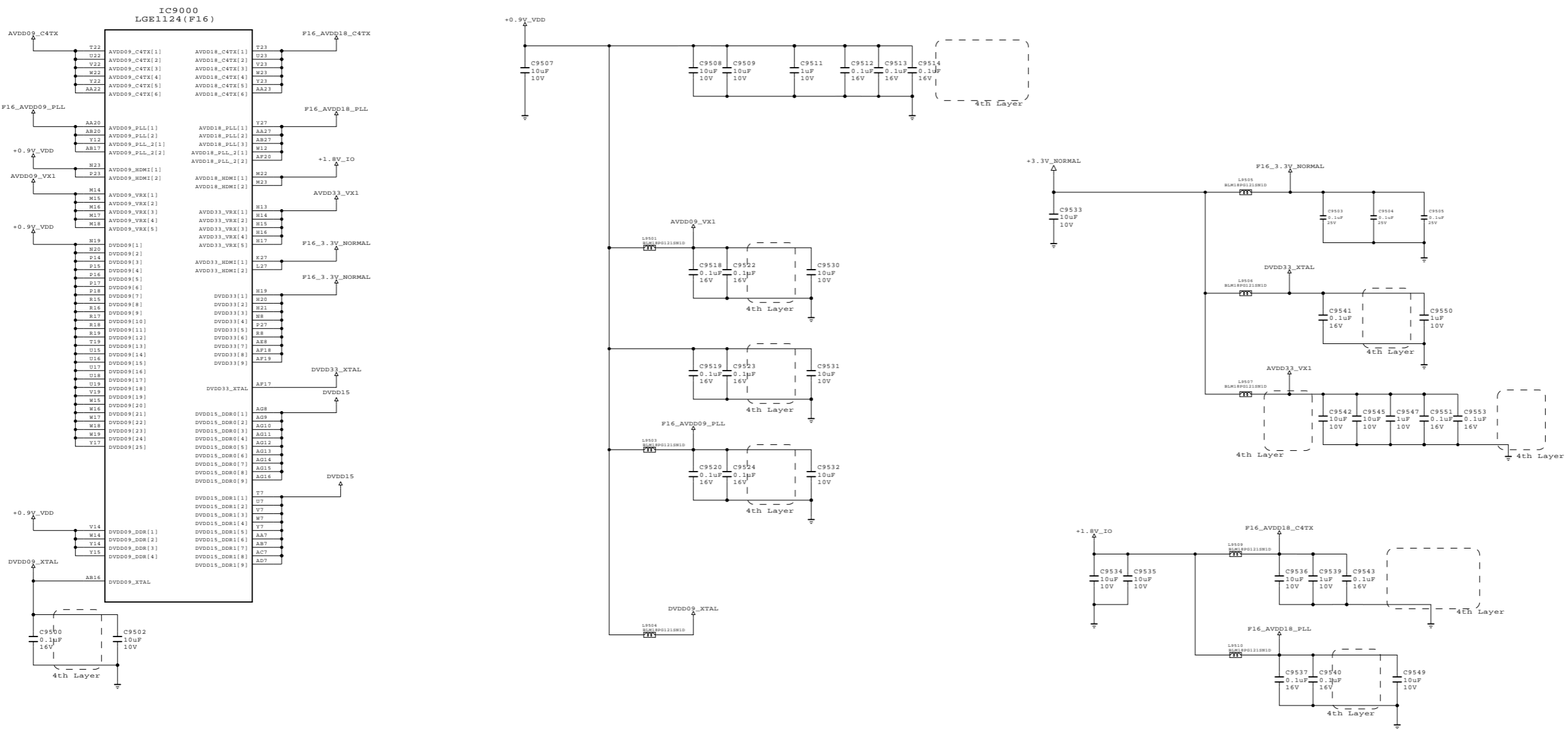

IC9000	LGE1124 (F16)	wp0t10	
D7	OND(1)	R23	
D8	OND(2)	R27	
D9	OND(3)	R28	
D15	OND(4)	R29	
D33	OND(5)	T6	
E5	OND(6)	T12	
E6	OND(7)	T13	
E7	OND(8)	T14	
E8	OND(9)	T15	
E9	OND(10)	T16	
E10	OND(11)	T17	
E11	OND(12)	T18	
E12	OND(13)	T20	
E13	OND(14)	T21	
E14	OND(15)	T22	
E15	OND(16)	T27	
E16	OND(17)	T28	
E26	OND(18)	T29	
E27	OND(19)	T6	
E31	OND(20)	T8	
E32	OND(21)	T12	
E33	OND(22)	T13	
F5	OND(23)	T14	
F6	OND(24)	T20	
F7	OND(25)	T21	
F8	OND(26)	T22	
F9	OND(27)	T27	
F10	OND(28)	T28	
F11	OND(29)	T29	
F12	OND(30)	T6	
F13	OND(31)	T12	
F14	OND(32)	T13	
F15	OND(33)	T14	
F16	OND(34)	T15	
F27	OND(35)	T16	
F28	OND(36)	T17	
F29	OND(37)	T18	
F30	OND(38)	T20	
F31	OND(39)	T21	
G5	OND(40)	T22	
G6	OND(41)	T27	
G7	OND(42)	T28	
G8	OND(43)	T29	
G9	OND(44)	T6	
G10	OND(45)	T12	
G11	OND(46)	T13	
G12	OND(47)	T14	
G13	OND(48)	T15	
G14	OND(49)	T16	
G15	OND(50)	T17	
G16	OND(51)	T18	
G17	OND(52)	T20	
G18	OND(53)	T21	
G19	OND(54)	T22	
G20	OND(55)	T27	
G21	OND(56)	T28	
G22	OND(57)	T29	
G23	OND(58)	T6	
G24	OND(59)	T12	
G25	OND(60)	T13	
G26	OND(61)	T14	
G27	OND(62)	T15	
G28	OND(63)	T16	
H3	OND(64)	T17	
H4	OND(65)	T18	
H5	OND(66)	T20	
H6	OND(67)	T21	
H7	OND(68)	T22	
H8	OND(69)	T27	
H9	OND(70)	T28	
H10	OND(71)	T29	
H11	OND(72)	T6	
H12	OND(73)	T12	
H13	OND(74)	T13	
H14	OND(75)	T14	
H15	OND(76)	T15	
H16	OND(77)	T16	
H17	OND(78)	T17	
H18	OND(79)	T18	
H19	OND(80)	T20	
H20	OND(81)	T21	
H21	OND(82)	T22	
H22	OND(83)	T27	
H23	OND(84)	T28	
H24	OND(85)	T29	
H25	OND(86)	T6	
H26	OND(87)	T12	
H27	OND(88)	T13	
H28	OND(89)	T14	
H29	OND(90)	T15	
H30	OND(91)	T16	
H31	OND(92)	T17	
H32	OND(93)	T18	
H33	OND(94)	T20	
H34	OND(95)	T21	
H35	OND(96)	T22	
H36	OND(97)	T27	
H37	OND(98)	T28	
H38	OND(99)	T29	
H39	OND(100)	T6	
H40	OND(101)	T12	
H41	OND(102)	T13	
H42	OND(103)	T14	
H43	OND(104)	T15	
H44	OND(105)	T16	
H45	OND(106)	T17	
H46	OND(107)	T18	
H47	OND(108)	T20	
H48	OND(109)	T21	
H49	OND(110)	T22	
H50	OND(111)	T27	
H51	OND(112)	T28	
H52	OND(113)	T29	
H53	OND(114)	T6	
H54	OND(115)	T12	
H55	OND(116)	T13	
H56	OND(117)	T14	
H57	OND(118)	T15	
H58	OND(119)	T16	
H59	OND(120)	T17	
H60	OND(121)	T18	
H61	OND(122)	T20	
H62	OND(123)	T21	
H63	OND(124)	T22	
H64	OND(125)	T27	
H65	OND(126)	T28	
H66	OND(127)	T29	
H67	OND(128)	T6	
H68	OND(129)	T12	
H69	OND(130)	T13	
H70	OND(131)	T14	
H71	OND(132)	T15	
H72	OND(133)	T16	
H73	OND(134)	T17	
H74	OND(135)	T18	
H75	OND(136)	T20	
H76	OND(137)	T21	
H77	OND(138)	T22	
H78	OND(139)	T27	
H79	OND(140)	T28	
H80	OND(141)	T29	
H81	OND(142)	T6	
H82	OND(143)	T12	
H83	OND(144)	T13	
H84	OND(145)	T14	
H85	OND(146)	T15	
H86	OND(147)	T16	
H87	OND(148)	T17	
H88	OND(149)	T18	
H89	OND(150)	T20	
H90	OND(151)	T21	
H91	OND(152)	T22	
H92	OND(153)	T27	
H93	OND(154)	T28	
H94	OND(155)	T29	
H95	OND(156)	T6	
H96	OND(157)	T12	
H97	OND(158)	T13	
H98	OND(159)	T14	
H99	OND(160)	T15	
H100	OND(161)	T16	

2. Power Off Sequence
 1.5V -> 0.9V -> 1.8V -> 3.3V

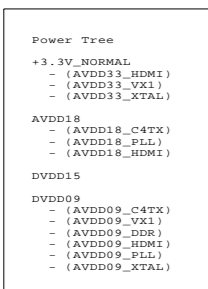

THE SYMBOL MARK OF THIS SCHEMATIC DIAGRAM INCORPORATES SPECIAL FEATURES IMPORTANT FOR PROTECTION FROM X-RADIATION. FIRE AND ELECTRICAL SHOCK HAZARDS, WHEN SERVICING IF IS ESSENTIAL THAT ONLY MANUFACTURERS SPECIFIED PARTS BE USED FOR THE CRITICAL COMPONENTS IN THE SYMBOL MARK OF THE SCHEMATIC.

SECRET
LGElectronics



MODEL	F16	DATE	2015.6.13
BLOCK	F16 Power	SHEET	95 / 100

F16 AVDD09_C4TX

Sheet separation
 Vx1 : 96_00
 EPI : 96_01

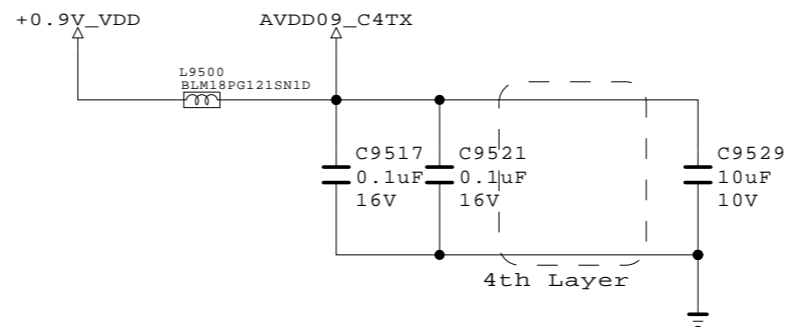

THE SYMBOL MARK OF THIS SCHEMATIC DIAGRAM INCORPORATES SPECIAL FEATURES IMPORTANT FOR PROTECTION FROM X-RADIATION. FIRE AND ELECTRICAL SHOCK HAZARDS, WHEN SERVICING IF IS ESSENTIAL THAT ONLY MANUFACTURES SPECIFIED PARTS BE USED FOR THE CRITICAL COMPONENTS IN THE SYMBOL MARK OF THE SCHEMATIC.

SECRET
 LGElectronics



MODEL	M16	DATE	2015.09.22
BLOCK	F16 AVDD09_C4TX	SHEET	/

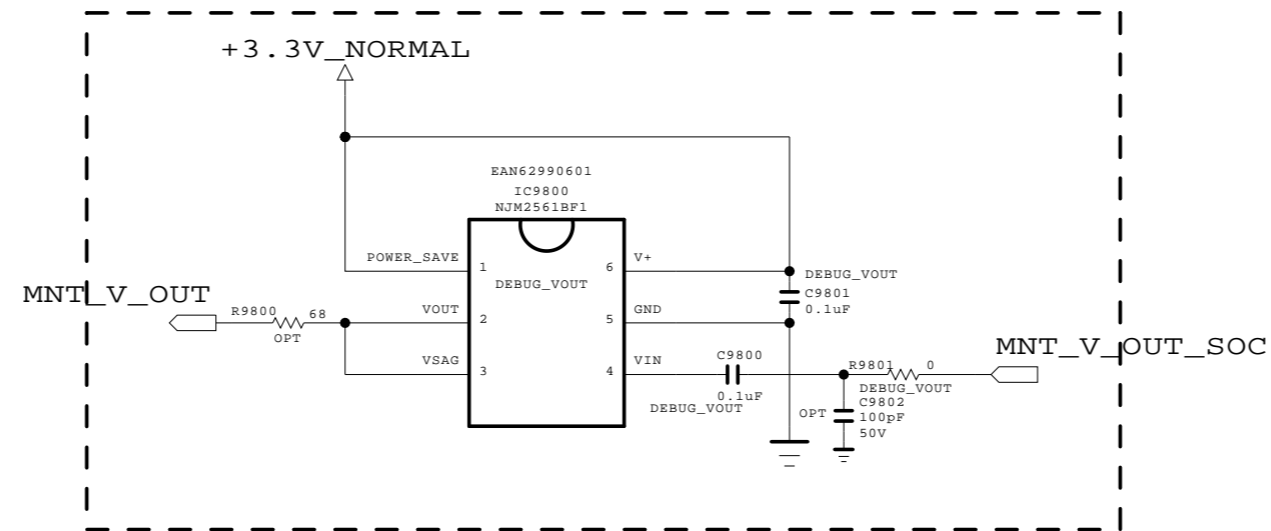

THE ⚠ SYMBOL MARK OF THIS SCHEMATIC DIAGRAM INCORPORATES SPECIAL FEATURES IMPORTANT FOR PROTECTION FROM X-RADIATION. FIRE AND ELECTRICAL SHOCK HAZARDS, WHEN SERVICING IF IS ESSENTIAL THAT ONLY MANUFACTURES SPECIFIED PARTS BE USED FOR THE CRITICAL COMPONENTS IN THE ⚠ SYMBOL MARK OF THE SCHEMATIC.

SECRET
LGElectronics



MODEL		DATE	15 / 08 / 24
BLOCK	DEBUG_MNV_VOUT	SHEET	/

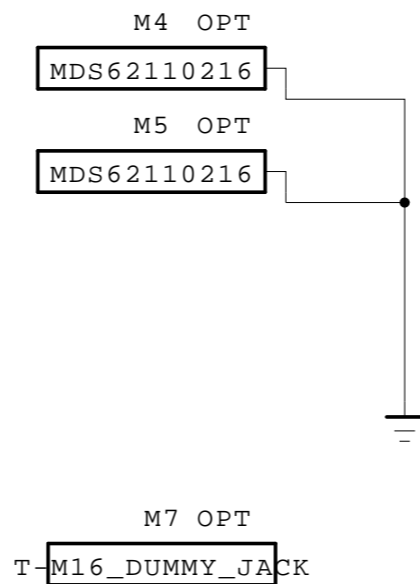

THE ⚠ SYMBOL MARK OF THIS SCHEMATIC DIAGRAM INCORPORATES SPECIAL FEATURES IMPORTANT FOR PROTECTION FROM X-RADIATION. FIRE AND ELECTRICAL SHOCK HAZARDS, WHEN SERVICING IT IS ESSENTIAL THAT ONLY MANUFACTURERS SPECIFIED PARTS BE USED FOR THE CRITICAL COMPONENTS IN THE ⚠ SYMBOL MARK OF THE SCHEMATIC.

SECRET
LGElectronics





MODEL		DATE	15/06/16
BLOCK	SMD GASKET	SHEET	73

LOGO_LIGHT

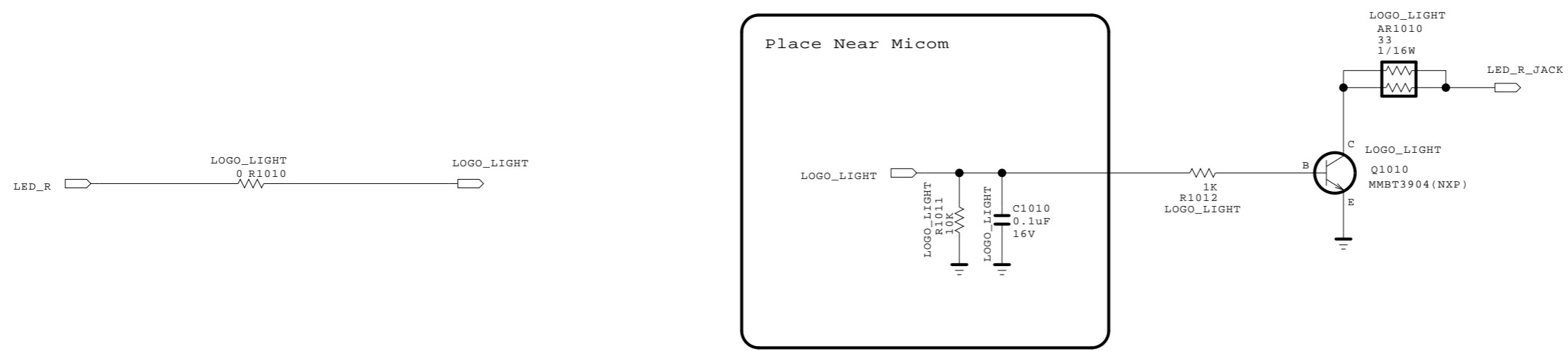
For 79UF95



Place Near Micom

THE  SYMBOL MARK OF THIS SCHEMATIC DIAGRAM INCORPORATES SPECIAL FEATURES IMPORTANT FOR PROTECTION FROM X-RADIATION. FIRE AND ELECTRICAL SHOCK HAZARDS, WHEN SERVICING IF IS ESSENTIAL THAT ONLY MANUFACTURES SPECIFIED PARTS BE USED FOR THE CRITICAL COMPONENTS IN THE  SYMBOL MARK OF THE SCHEMATIC.

SECRET LGElectronics	 LG ELECTRONICS	MODEL	LOGO_LIGHT	DATE	2015.6.13
		BLOCK	LOGO_LIGHT	SHEET	/



TROUBLE SHOOTING GUIDE

Contents of Standard Repair Process

No.	Error symptom (High category)	Error symptom (Mid category)	Page	Remarks
1	A. Video error	No video/Normal audio	1	
2		No video/No audio	2	
3		Picture broken/ Freezing	3	
4		Color error	4	
5		Vertical/Horizontal bar, residual image, light spot, external device color error	5	
6	B. Power error	No power	6	
7		Off when on, off while viewing, power auto on/off	7	
8	C. Audio error	No audio/Normal video	8	
9		Wrecked audio/discontinuation/noise	9	
10	D. Function error	Remote control & Local switch checking	10	
11		MR15R operating checking	11	
12		Wifi operating checking	12	
13		Camera operating checking	13	
14		External device recognition error	14	
15	E. Noise	Circuit noise, mechanical noise	15	
16	F. Exterior error	Exterior defect	16	

First of all, Check whether there is SVC Bulletin in GSCS System for these model.

	Error symptom	A. Video error	Established date	
		No video/ Normal audio	Revised date	1/16

First of all, Check whether all of cables between board is inserted properly or not.
(Main B/D↔ Power B/D, Vx1/EPI Cable, Speaker Cable, IR B/D Cable,,)

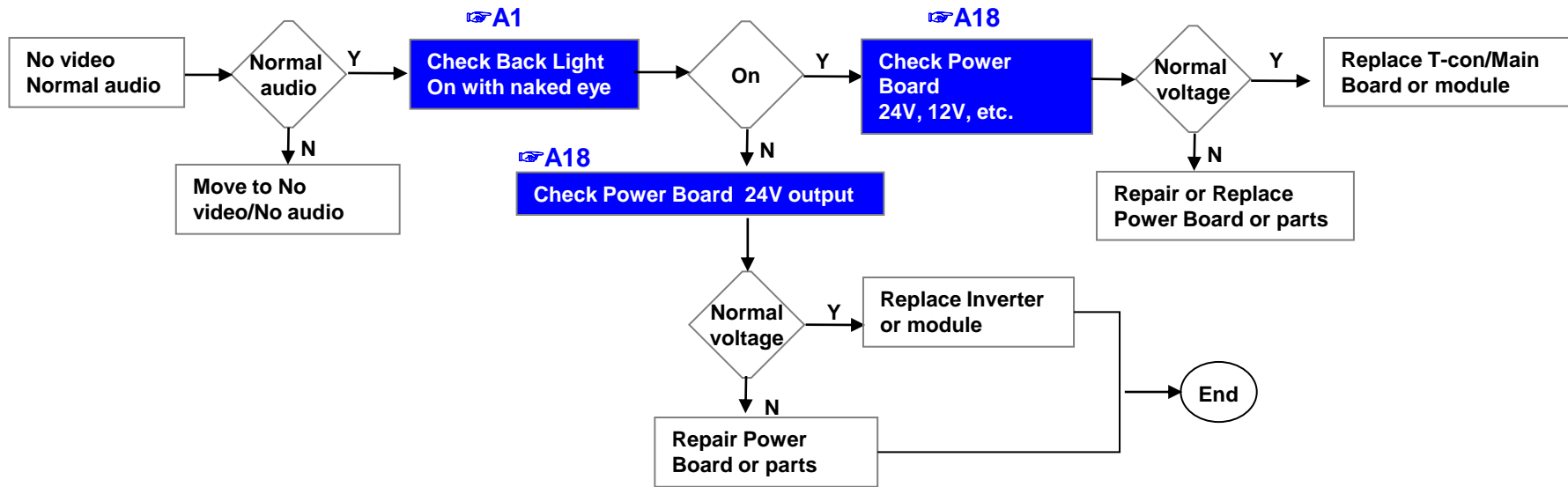

※Precaution A4 & A2

Always check & record S/W Version and White Balance value before replacing the Main Board

Replace Main Board

Re-enter White Balance value

Standard Repair Process

	Error symptom	A. Video error	Established date		
		No video/ No audio	Revised date		2/16

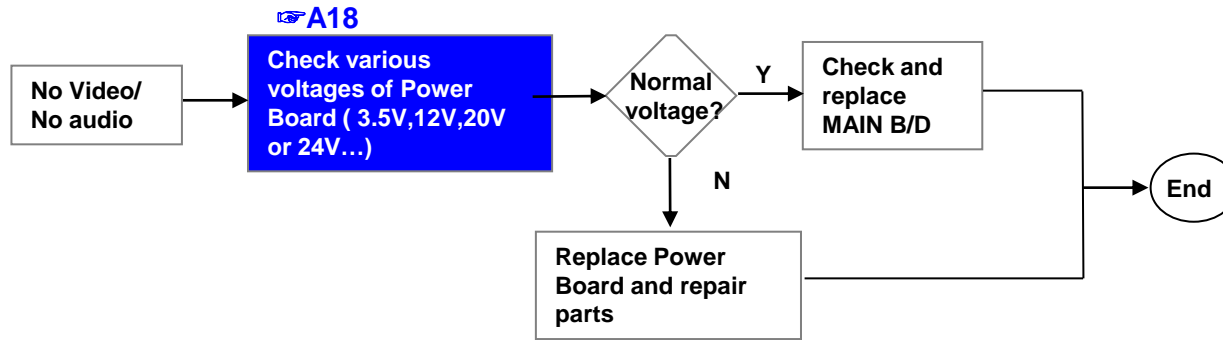

	Error symptom	A. Video error	Established date		
		Picture broken/ Freezing	Revised date		3/16

A3

Check RF Signal level

- . By using Digital signal level meter
- . By using Diagnostics menu on OSD
(All Settings → Programmes → Programmes Tuning &Settings → Manual Tuning → Check the Signal)
- Signal strength (Normal : over 50%)
- Signal Quality (Normal: over 50%)

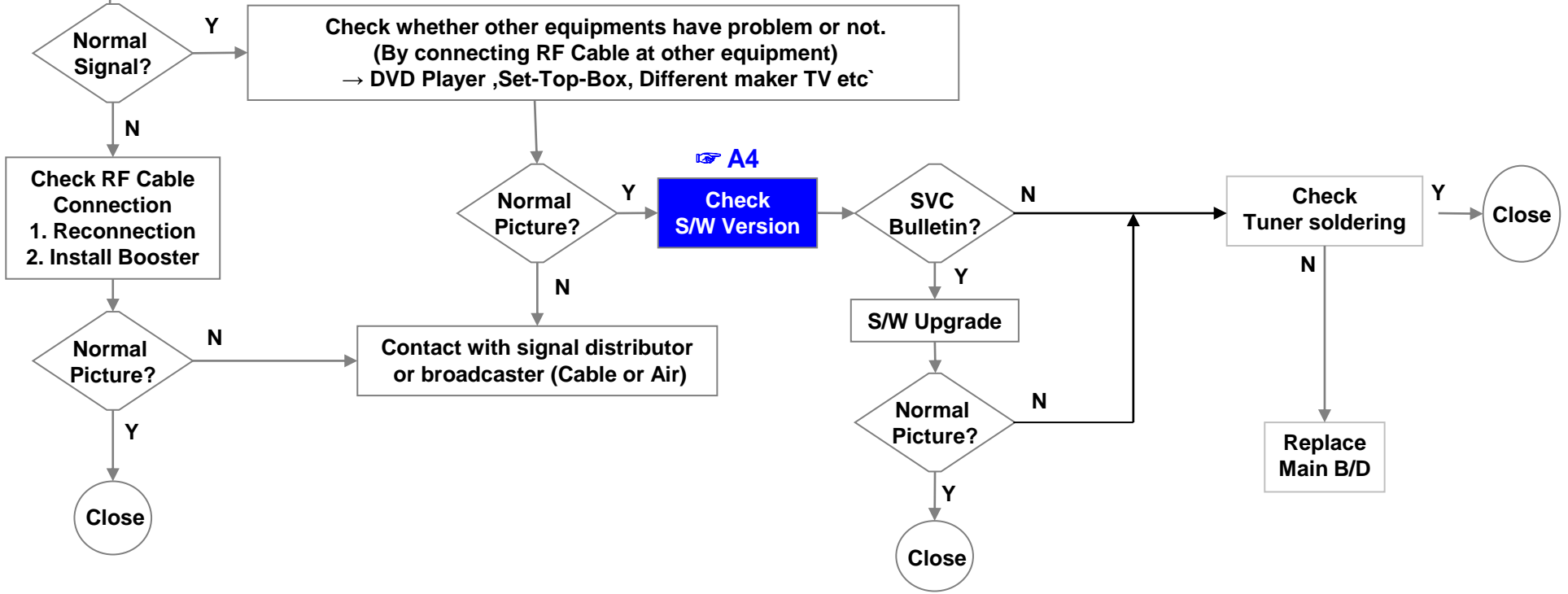

Error symptom	A. Video error		Established date	
	Color error		Revised date	4/16

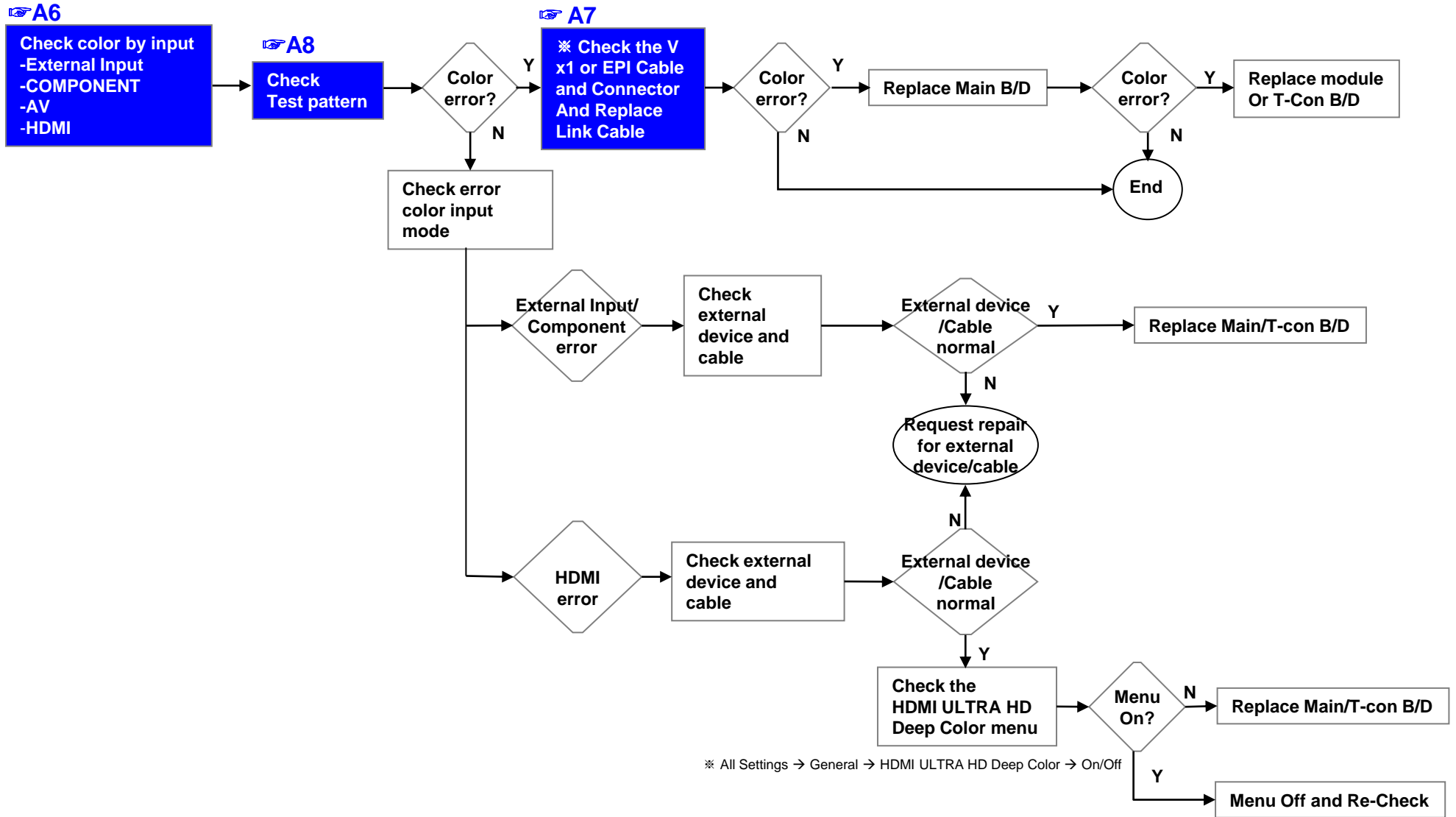

Error symptom	A. Video error	Established date	
	Vertical / Horizontal bar, residual image, light spot, external device color error	Revised date	5/16

Vertical/Horizontal bar, residual image, light spot

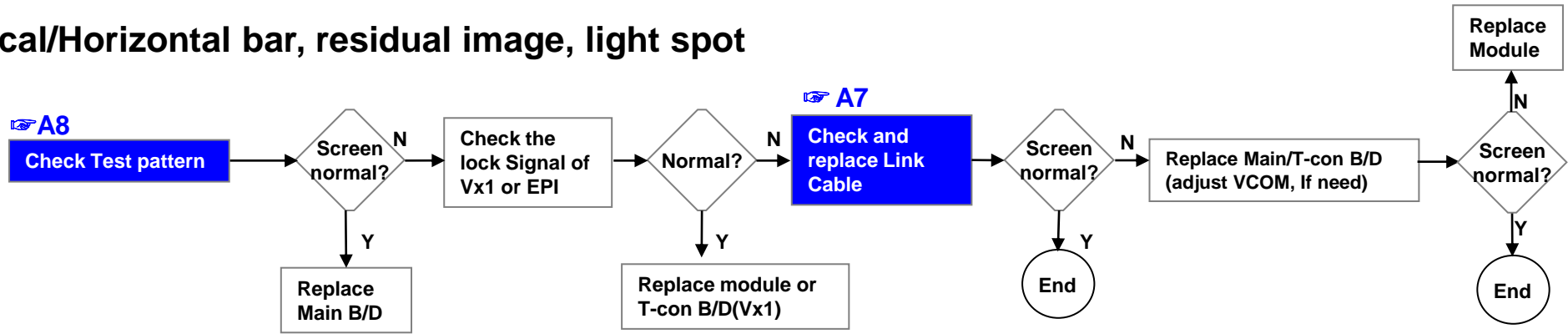

External device screen error-Color error

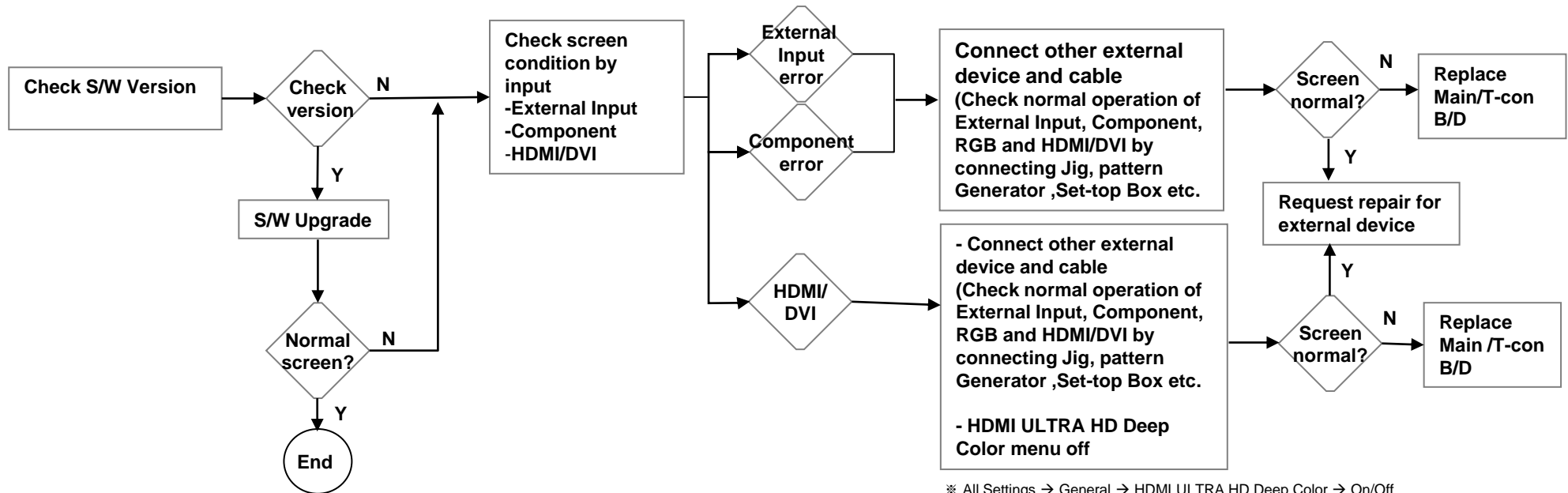

	Error symptom	B. Power error	Established date		
		No power	Revised date		6/16

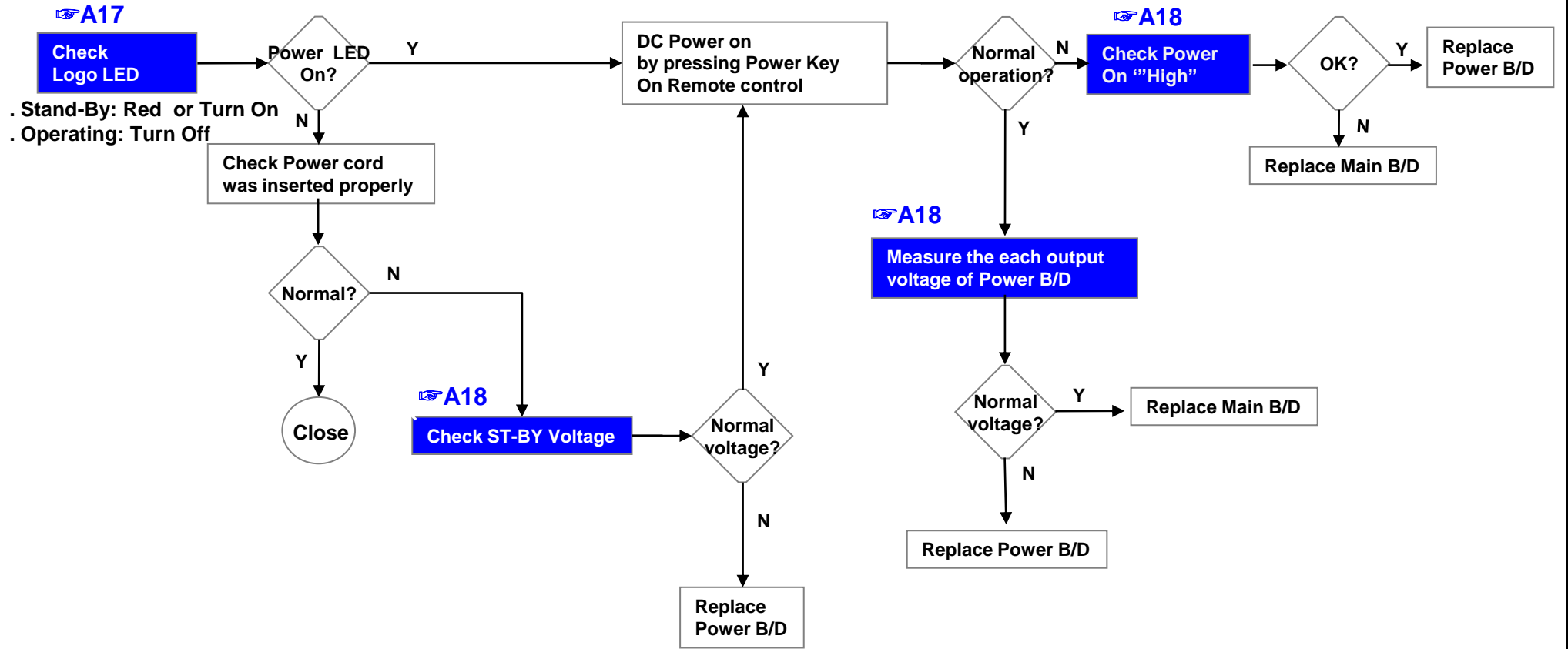

Standard Repair Process

Error symptom	B. Power error	Established date	
	Off when on, off while viewing, power auto on/off	Revised date	7/16

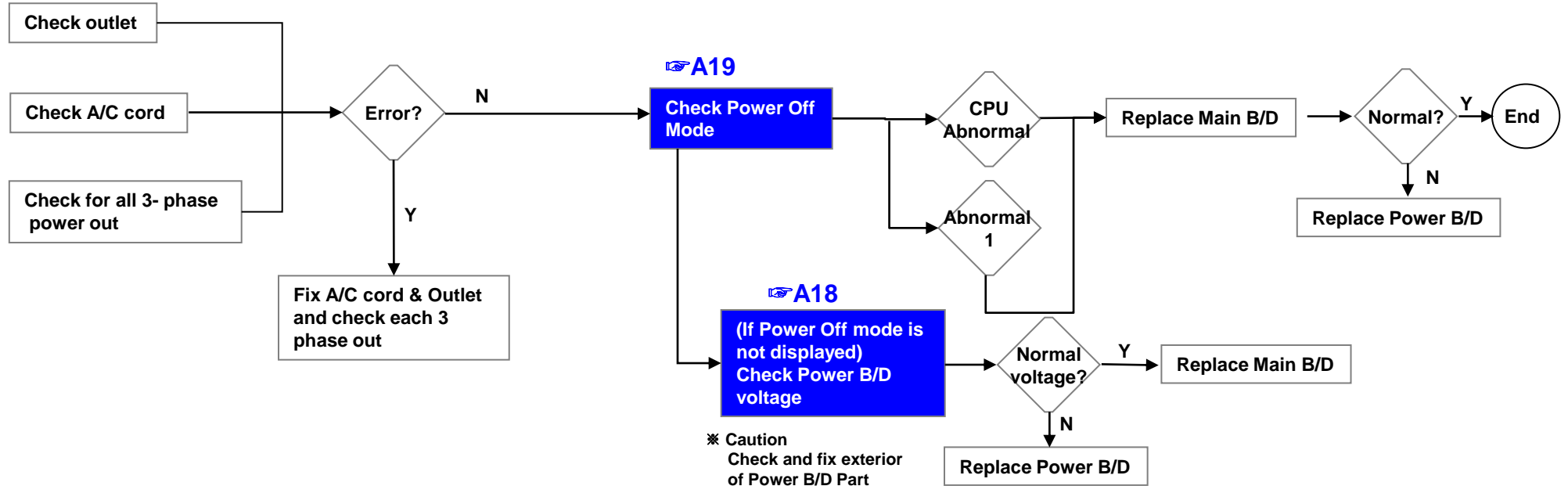

* Please refer to the all cases which can be displayed on power off mode.

Status	Power off List	Explanation
Normal	"POWEROFF_REMOTEKEY"	Power off by REMOTE CONTROL
	"POWEROFF_OFFTIMER"	Power off by OFF TIMER
	"POWEROFF_SLEEPTIMER"	Power off by SLEEP TIMER
	"POWEROFF_INSTOP"	Power off by INSTOP KEY
	"POWEROFF_AUTOOFF"	Power off by AUTO OFF
	"POWEROFF_ONTIMER"	Power off by ON TIMER
	"POWEROFF_RS232C"	Power off by RS232C
	"POWEROFF_RESREC"	Power off by Reserved Record
	"POWEROFF_RECEND"	Power off by End of Recording
	"POWEROFF_SWDOWN"	Power off by S/W Download
Abnormal	"POWEROFF_UNKNOWN"	Power off by unknown status except listed case
	"POWEROFF_ABNORMAL1"	Power off by abnormal status except CPU trouble
	"POWEROFF_CPUABNORMAL"	Power off by CPU Abnormal

	Error symptom	C. Audio error	Established date		
		No audio/ Normal video	Revised date		8/16

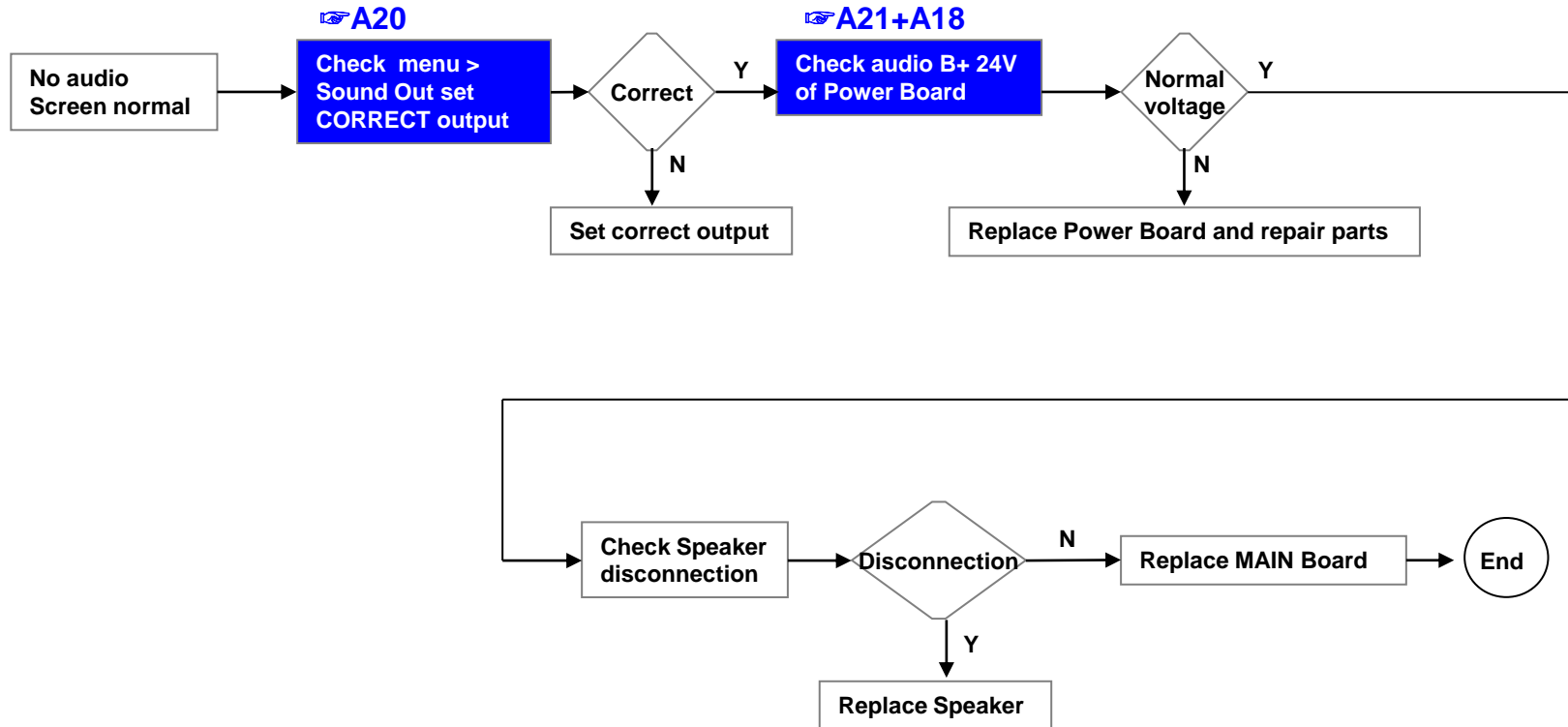

Error symptom	C. Audio error		Established date	
	Wrecked audio/ discontinuation/noise		Revised date	9/16

→ abnormal audio/discontinuation/noise is same after “Check input signal” compared to No audio

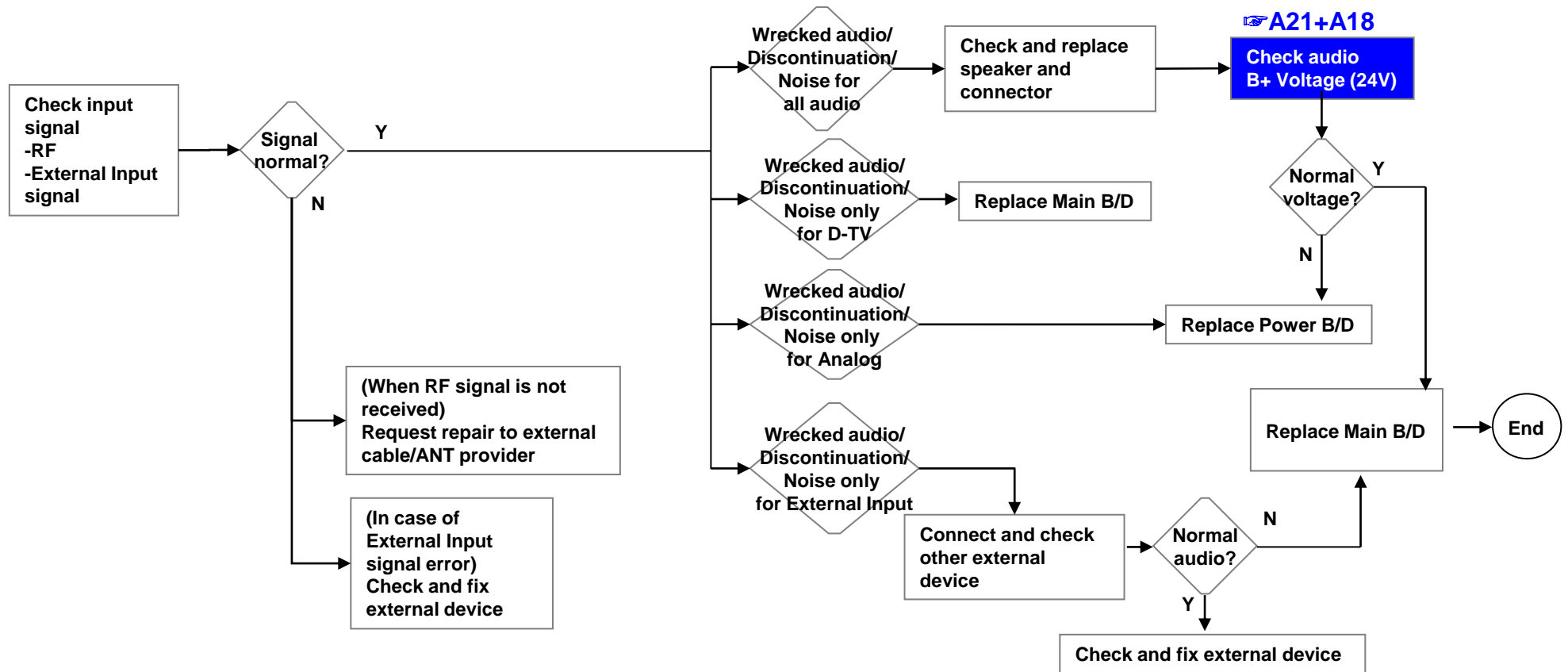

	Error symptom	D. Function error	Established date	
		Remote control & Local switch checking	Revised date	10/16

1. Remote control(R/C) operating error

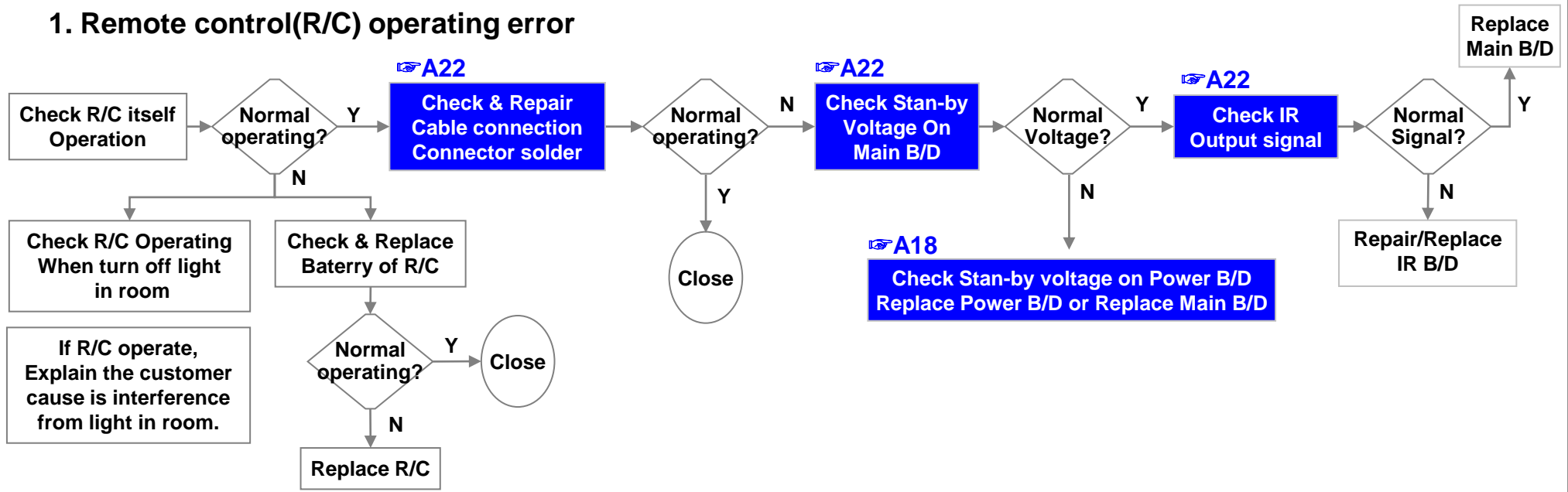

	Error symptom	D. Function error	Established date		
		MR15R operating checking	Revised date		11/16

2. MR15R(Magic Remocon) operating error

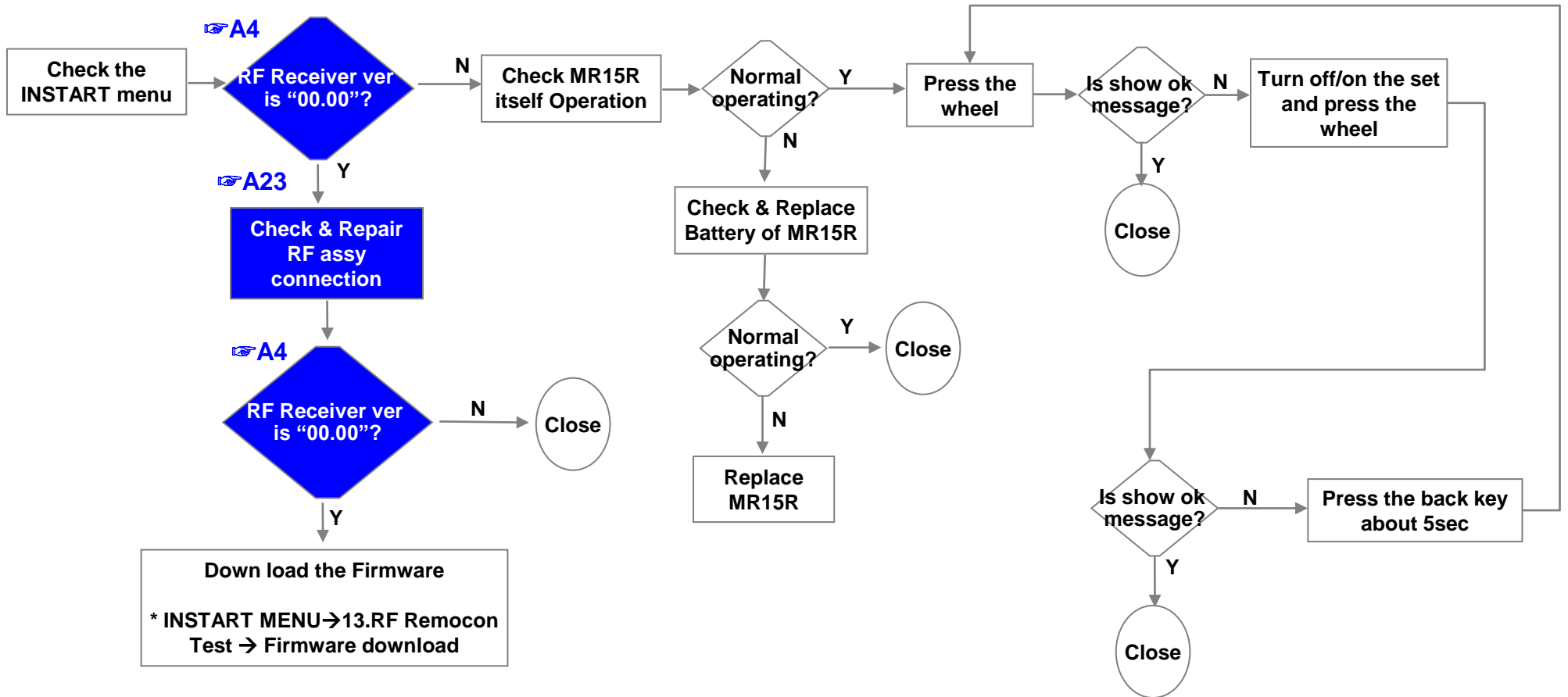

* If you conduct the loop at 3times, change the MR15R.

Error symptom	D. Function error	Established date	
	Wifi operating checking	Revised date	12/16

3.Wifi operating error

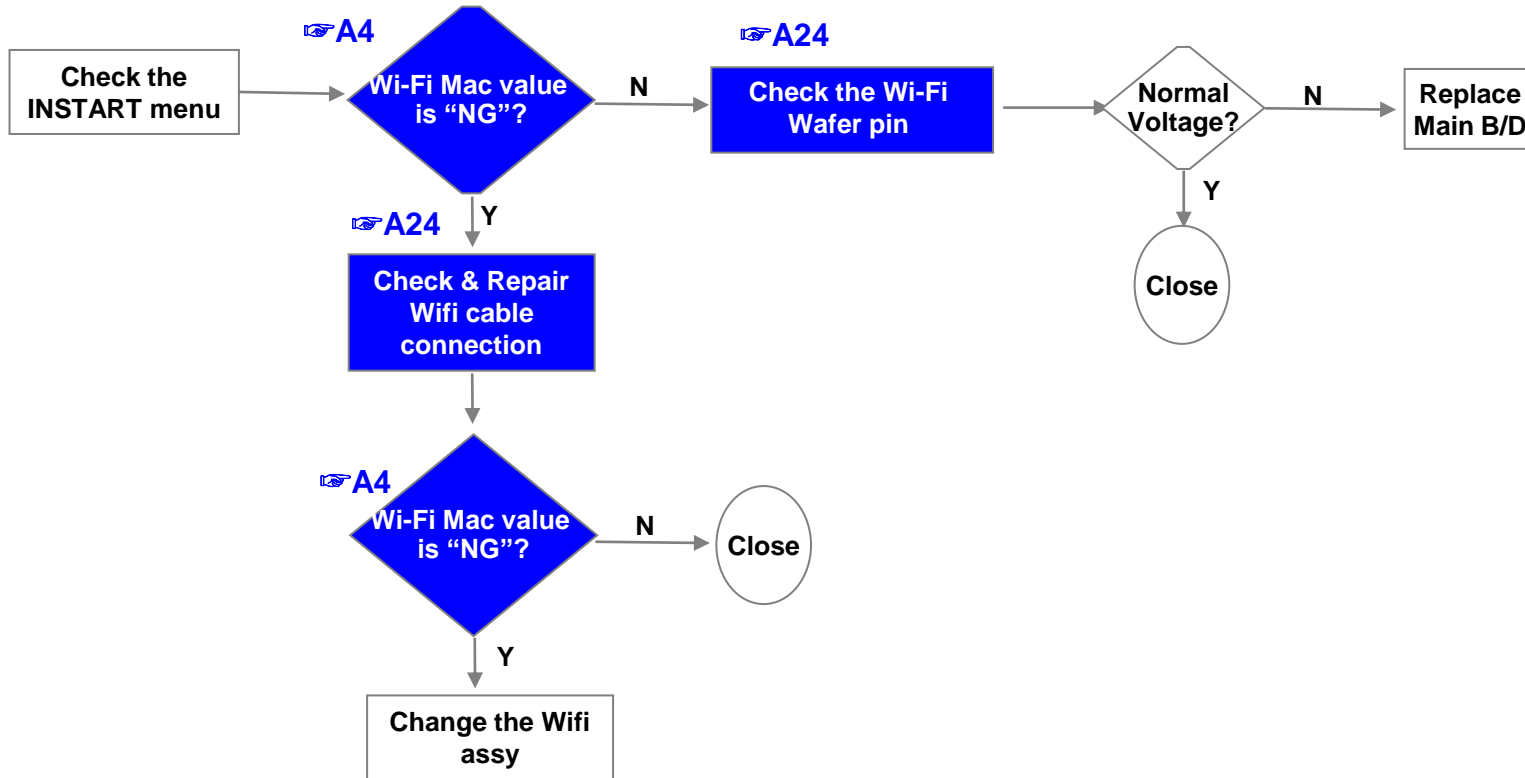

	Error symptom	D. Function error	Established date		
		Camera operating checking	Revised date		13/16

4.Camera operating error
(Only Camera Build-in model)

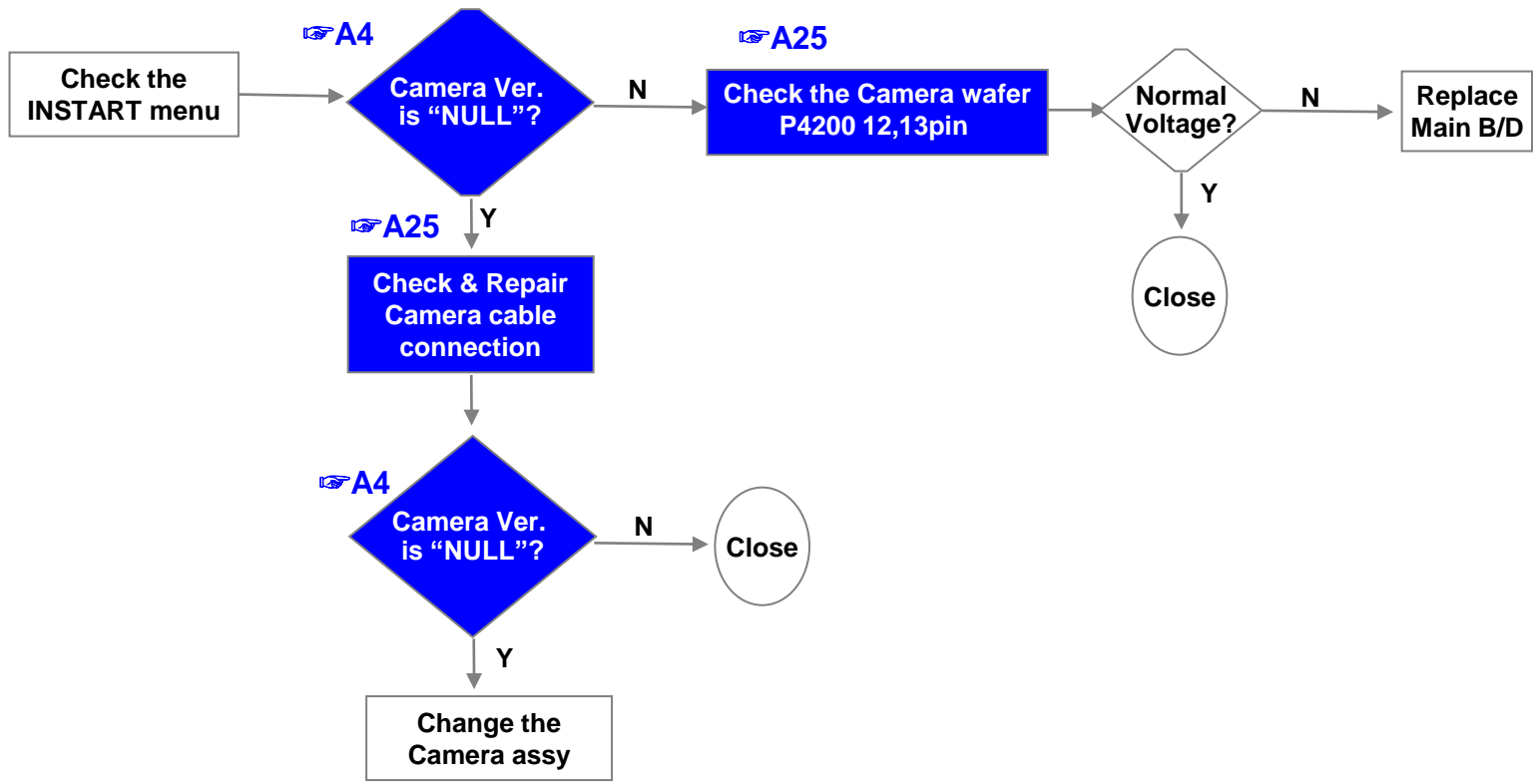

	Error symptom	D. Function error	Established date	
		External device recognition error	Revised date	14/16

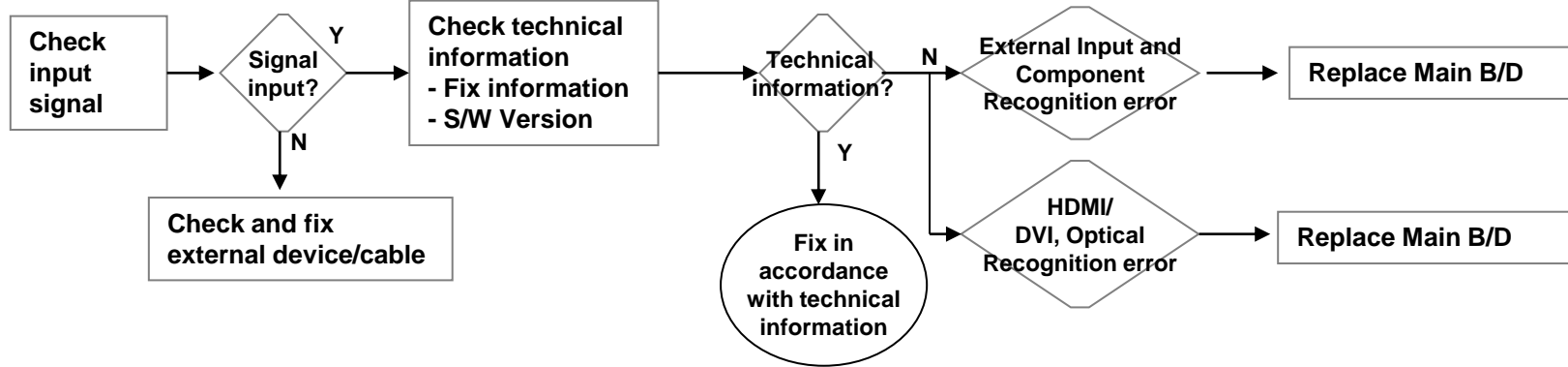

	Error symptom	E. Noise	Established date		
		Circuit noise, mechanical noise	Revised date		15/16

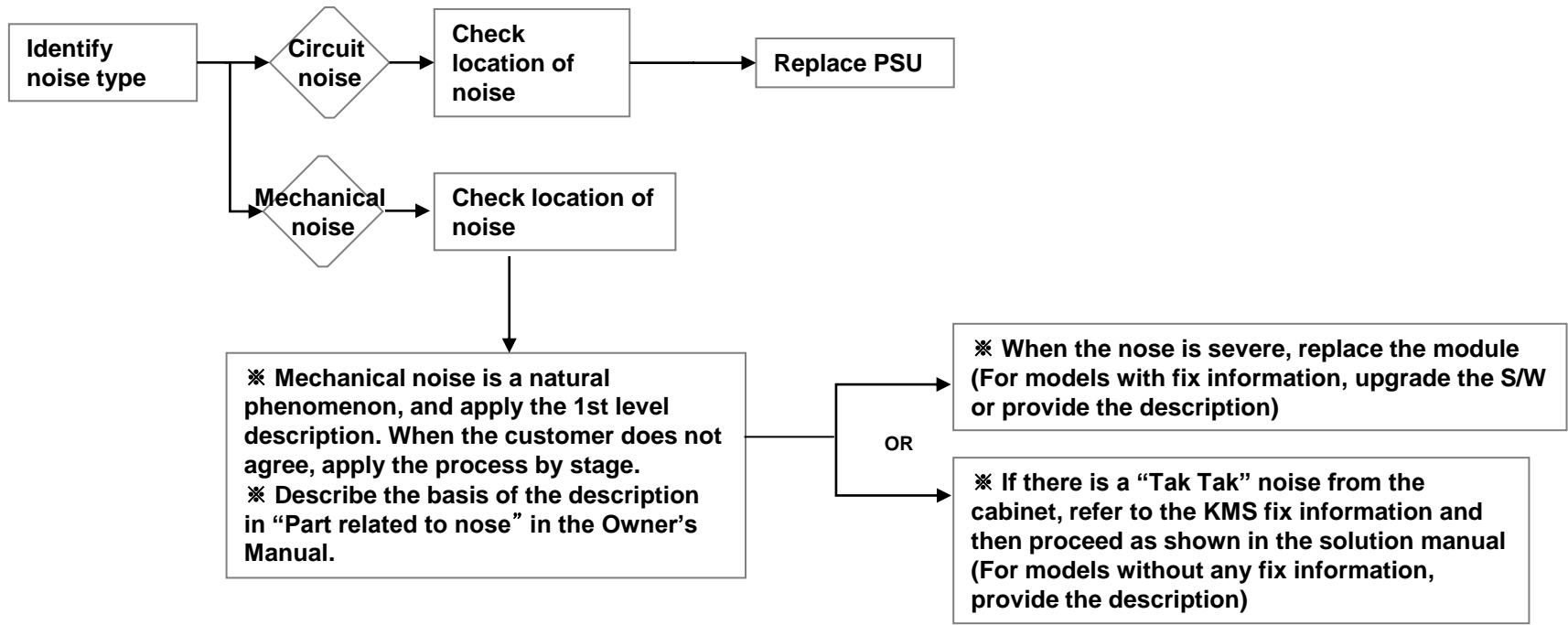

	Error symptom	F. Exterior defect	Established date		
		Exterior defect	Revised date		16/16

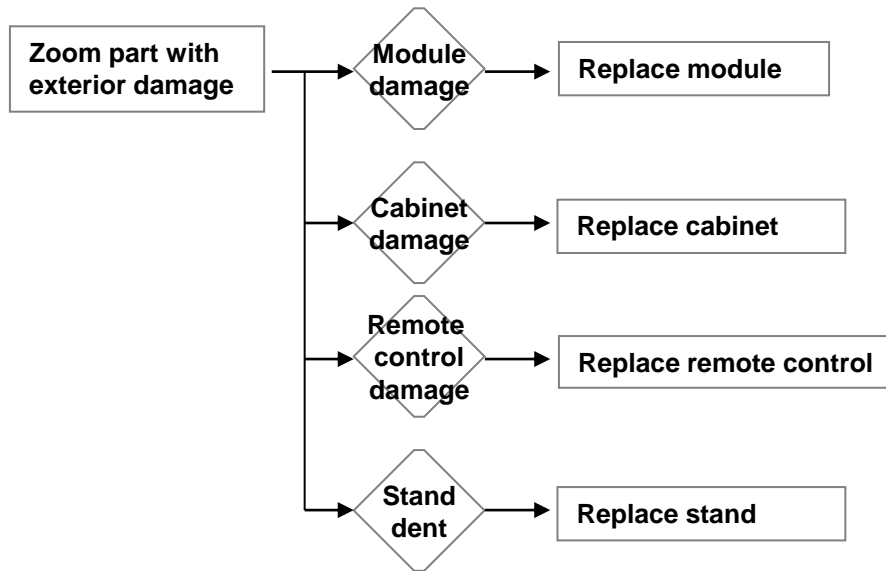

Contents of Standard Repair Process Detail Technical Manual

No.	Error symptom	Content	Page	Remarks
1	A. Video error_ No video/Normal audio	Check LCD back light with naked eye	A1	
2		Check White Balance value	A2	
3	A. Video error_ video error /Video lag/stop	TUNER input signal strength checking method	A3	
4		Version checking method	A4	
5		Tuner Checking Part	A5	
6	A. Video error _Vertical/Horizontal bar, residual image, light spot	connection diagram	A6	
7	A. Video error_ Color error	Check Link Cable (EPI) reconnection condition	A7	
8		Adjustment Test pattern - ADJ Key	A8	
9	<Appendix> Defected Type caused by T-Con/ Inverter/ Module	Exchange Main Board (1)	A-1/5	
10		Exchange Main Board (2)	A-2/5	
11		Exchange Power Board (PSU)	A-3/5	
12		Exchange Module (1)	A-4/5	
13		Exchange Module (2)	A-5/5	

Contents of Standard Repair Process Detail Technical Manual

No.	Error symptom	Content	Page	Remarks
14	B. Power error_ No power	Check front display Indicator	A17	
15		Check power input Voltage & ST-BY 3.5V	A18	
16	B. Power error_Off when on, off while viewing	POWER OFF MODE checking method	A19	
17	C. Audio error_ No audio/Normal video	Checking method in menu when there is no audio	A20	
18		Voltage and speaker checking method when there is no audio	A21	
19	D. Function error	Remote control operation checking method	A22	
20		Motion Remote operation checking method	A23	

Standard Repair Process Detail Technical Manual

Error symptom	A. Video error_No video/Normal audio	Established date		
Content	Check LCD back light with naked eye	Revised date		A1

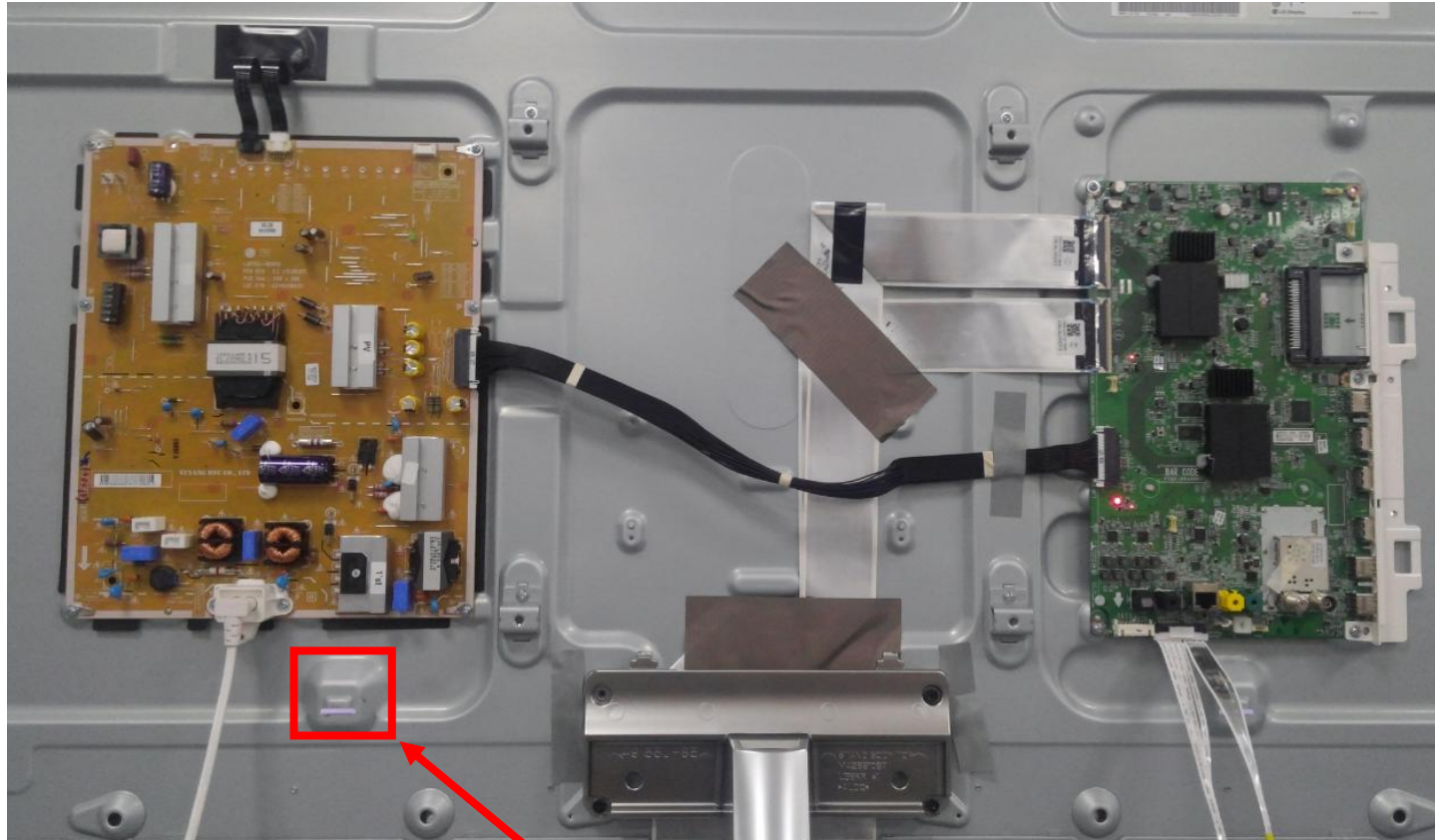

After turning on the power and disassembling the case, check with the naked eye, whether you can see light from locations.

A1

Standard Repair Process Detail Technical Manual

Error symptom	A. Video error_No video/Normal audio	Established date		
Content	Check White Balance value	Revised date		A2

<ALL MODELS>

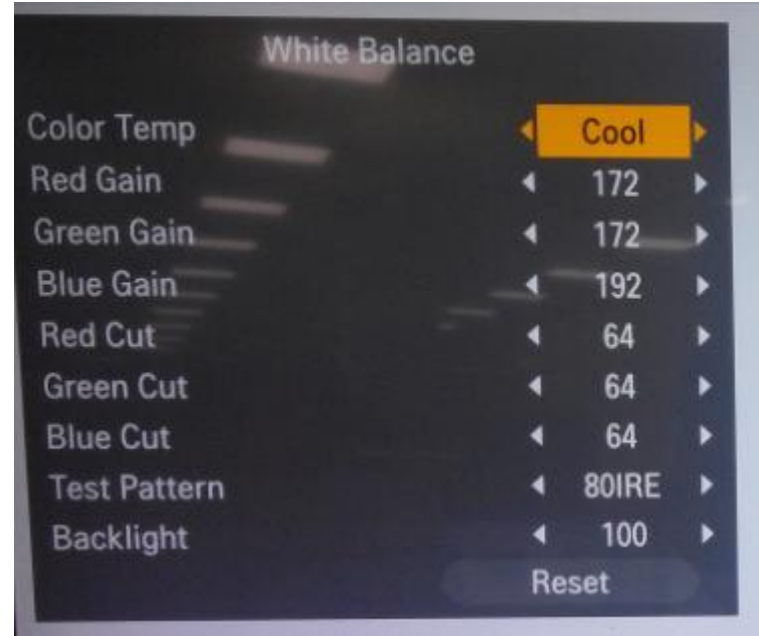
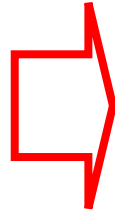
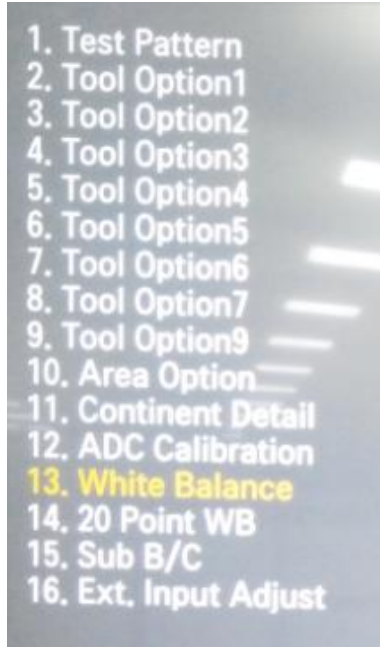

Entry method

1. Press the ADJ button on the remote control for adjustment.
2. Enter into White Balance of item 13.
3. After recording the R, G, B (GAIN, Cut) value of Color Temp (Cool/Medium/Warm), re-enter the value after replacing the MAIN BOARD.

A2

Standard Repair Process Detail Technical Manual

	Error symptom	A. Video error_Video error, video lag/stop	Established date		
	Content	TUNER input signal strength checking method	Revised date		A3

<ALL MODELS>

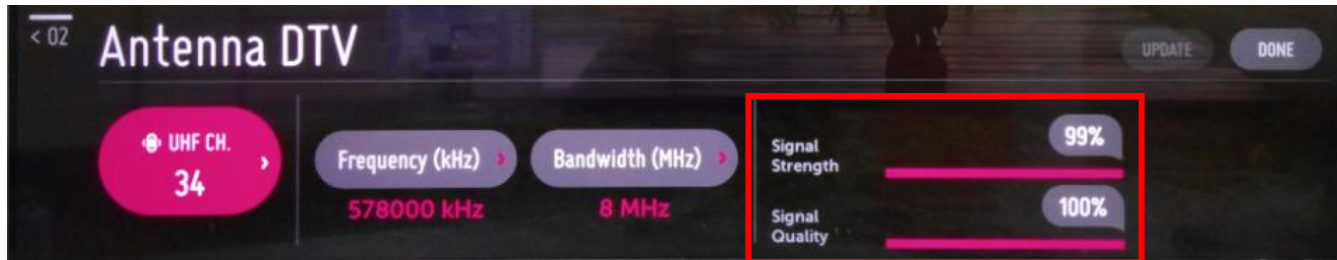
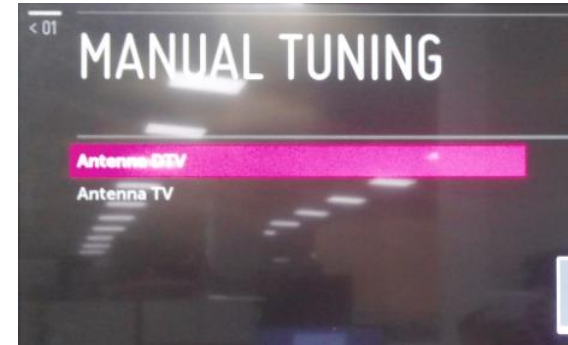
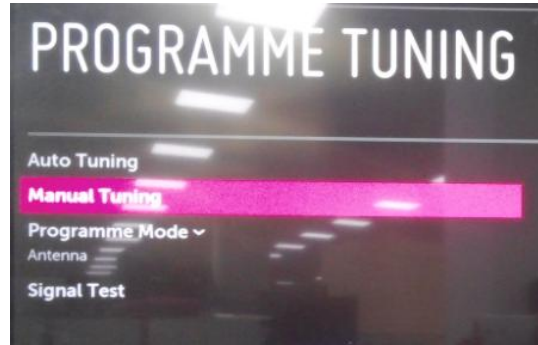

All Settings → Programmes → Programmes Tuning & Settings → Manual Tuning → Antenna DTV

Signal Strength is too strong : Use attenuator (-10dB, -15dB, -20dB etc.)
 Signal Strength is too weak : Use Signal Booster



Standard Repair Process Detail Technical Manual

	Error symptom	A. Video error_Video error, video lag/stop	Established date		
	Content	Version checking method	Revised date		A4

<ALL MODELS>

1. Checking method for remote control for adjustment

Version

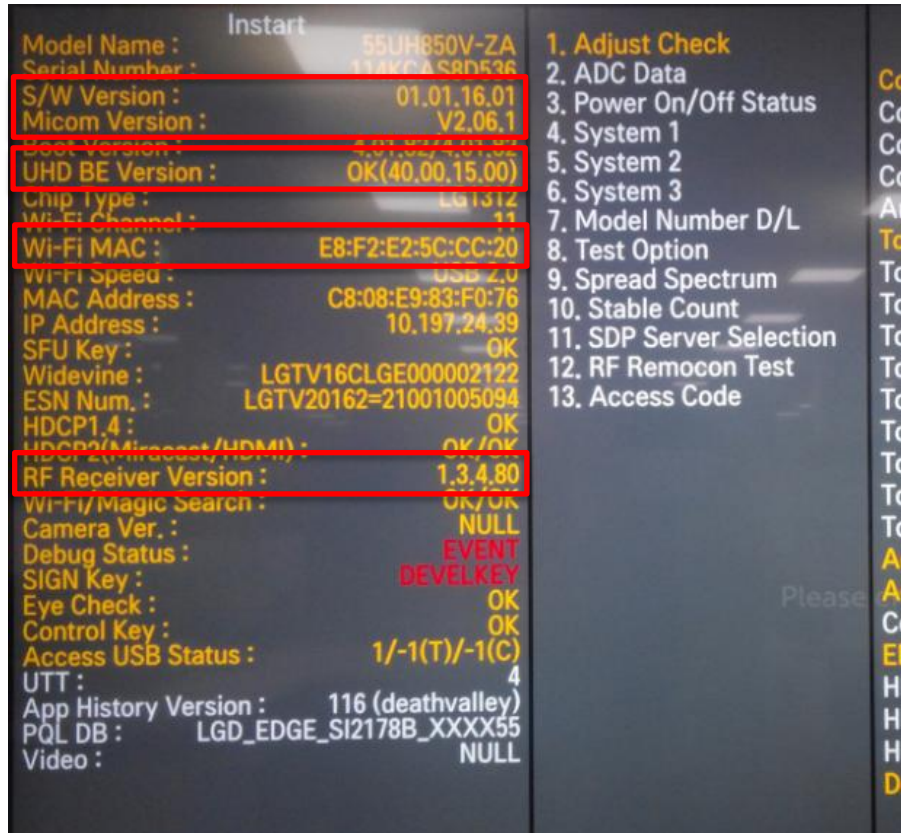

Press the IN-START with the remote control for adjustment

Standard Repair Process Detail Technical Manual

	Error symptom	A. Video error_Video error, video lag/stop	Established date		
	Content	TUNER checking part	Revised date		A5

<ALL MODELS>

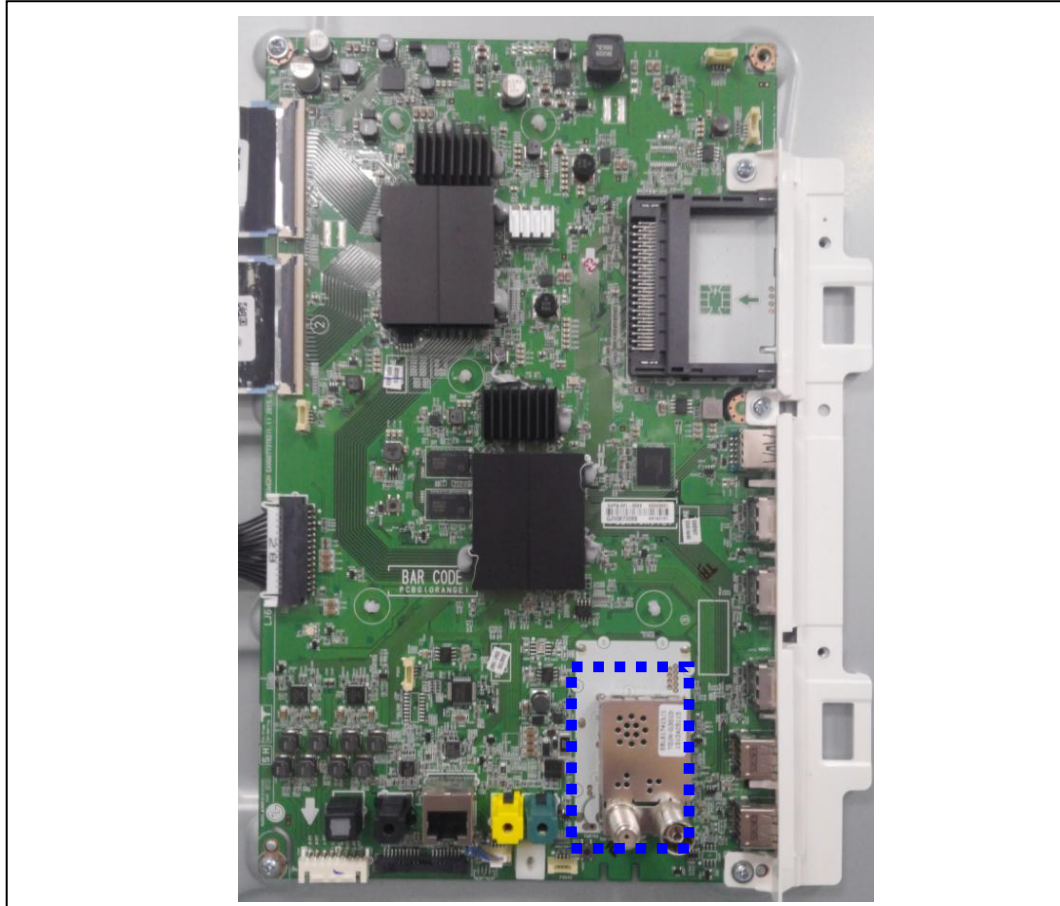

Checking method:

1. Check the signal strength or check whether the screen is normal when the external device is connected.
2. After measuring each voltage from power supply, finally replace the MAIN BOARD.

A5

Standard Repair Process Detail Technical Manual

	Error symptom	A. Video error _Vertical/Horizontal bar, residual image, light spot	Established date		
	Content	connection diagram (1)	Revised date		A6

<ALL MODELS>

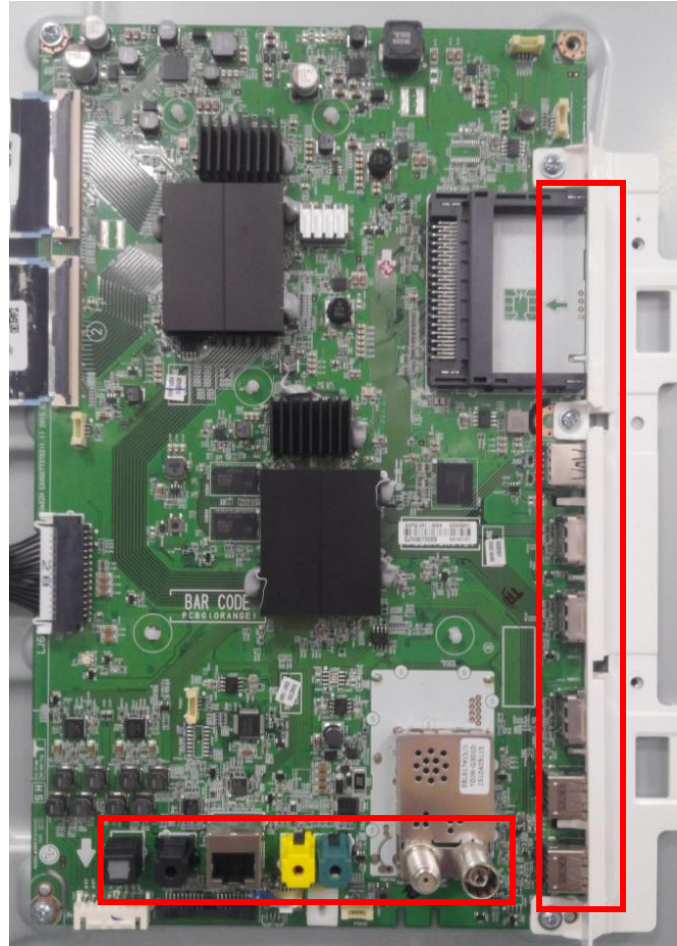

As the part connecting to the external input, check the screen condition by signal

A6

Standard Repair Process Detail Technical Manual

Error symptom	A. Video error_Color error	Established date		
Content	Check Link Cable (EPI) reconnection condition	Revised date		A7

<ALL MODELS>

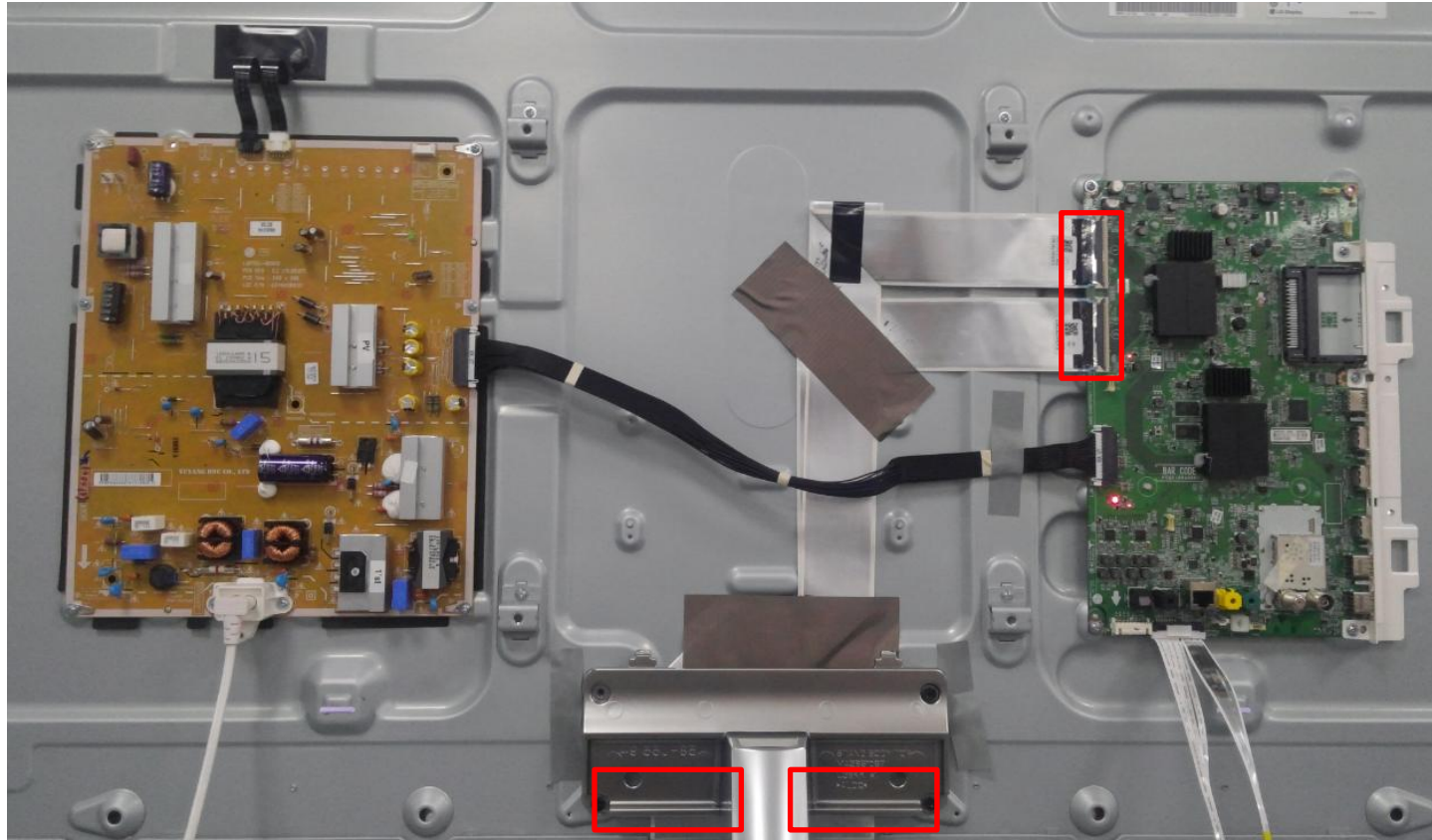

Check the contact condition of the Link Cable, especially dust or mis insertion.

Standard Repair Process Detail Technical Manual

	Error symptom	A. Video error_Color error	Established date		
	Content	Adjustment Test pattern - ADJ Key	Revised date		A8

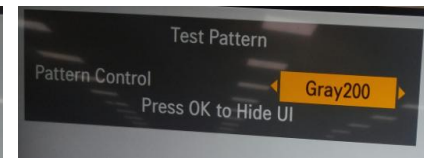
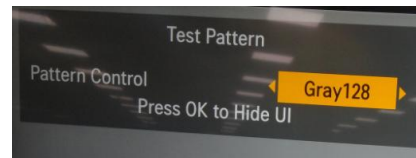
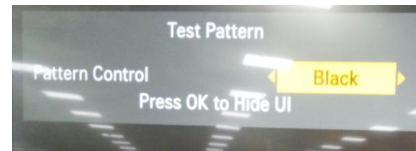
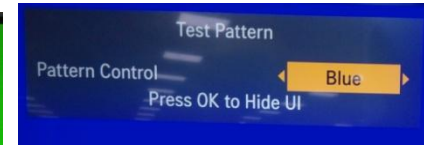
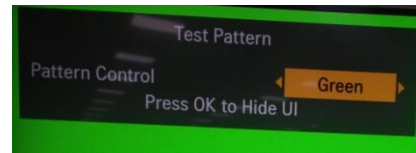
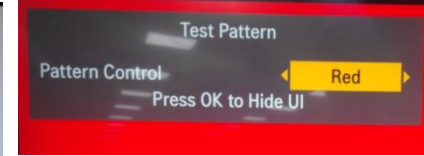
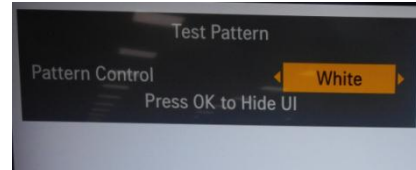
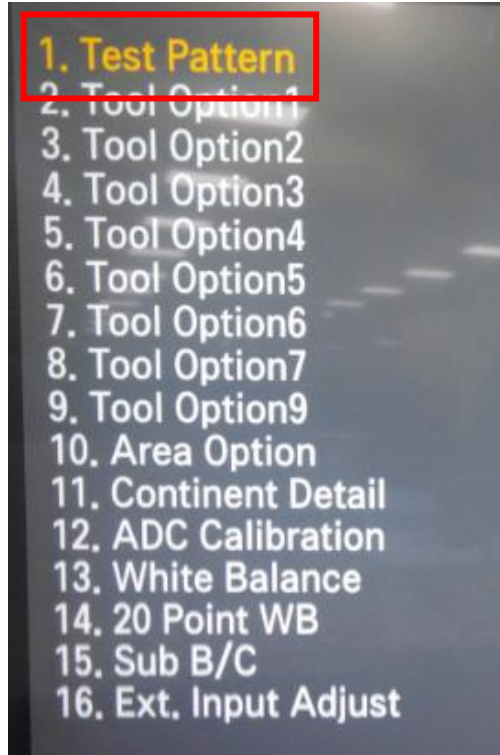

You can view 8 types of patterns using the ADJ Key

Checking item : 1. Defective pixel 2. Residual image 3. MODULE error (ADD-BAR,SCAN BAR..)
4.Video error (Classification of MODULE or Main-B/D)

Appendix : Exchange Main Board (1)



Solder defect, CNT Broken

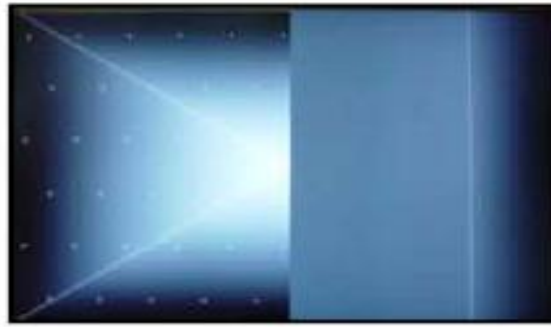

Solder defect, CNT Broken

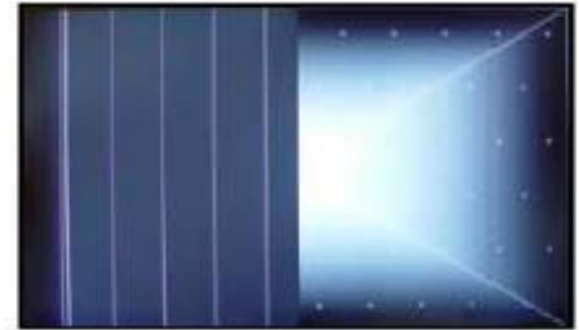

Solder defect, CNT Broken



Solder defect, CNT Broken

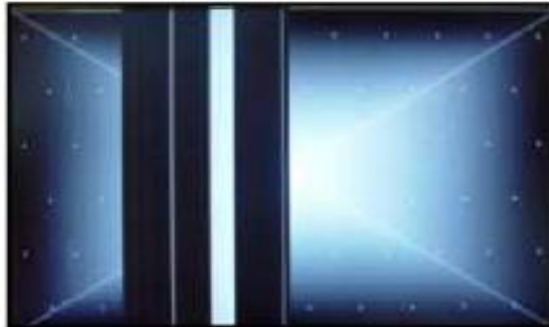

Solder defect, CNT Broken



Abnormal Power Section

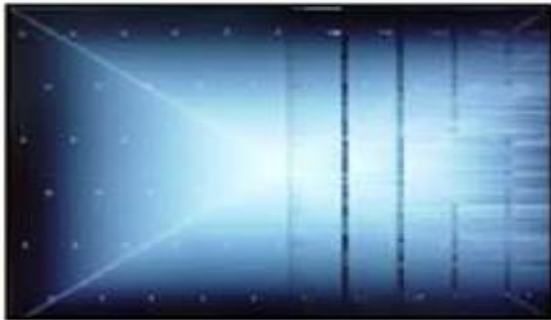

Solder defect, Short/Crack



Abnormal Power Section



Solder defect, Short/Crack

Appendix : Exchange Main Board (2)

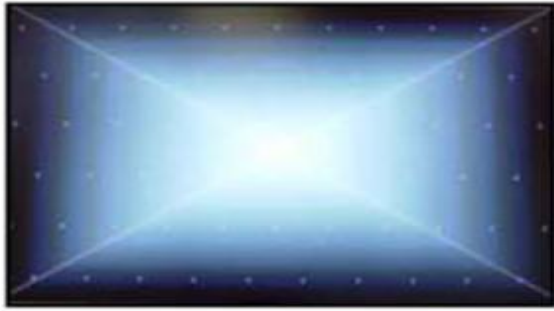

Abnormal Power Section



Abnormal Power Section



Solder defect, Short/Crack



Solder defect, Short/Crack



Fuse Open, Abnormal power section



Abnormal Display

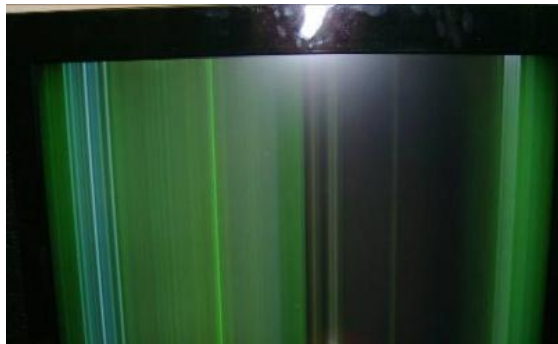

GRADATION



Noise



GRADATION

Appendix : Exchange Power Board (PSU)



No Light



Dim Light



Dim Light

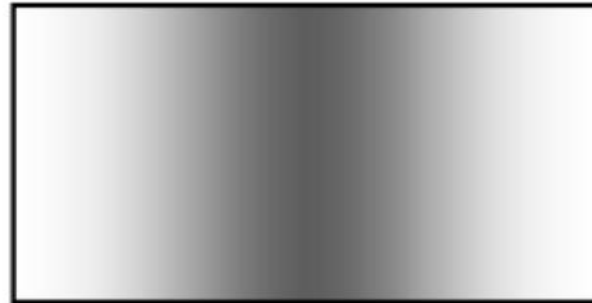

Dim Light



No picture/Sound Ok

Appendix : Exchange the Module (1)

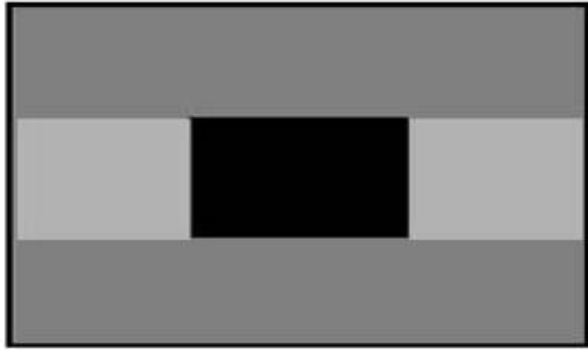

Crosstalk



Press damage



Crosstalk



Press damage



Press damage

Un-repairable Cases
In this case please exchange the module.

Appendix : Exchange the Module (2)

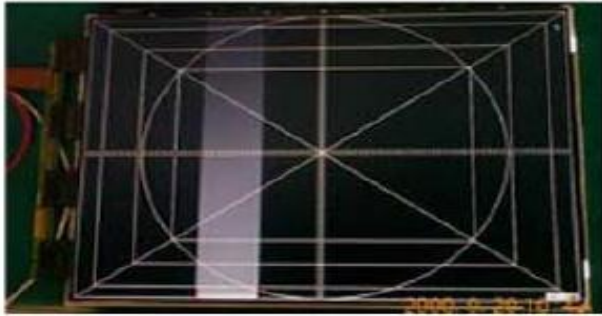

**Vertical Block
Source TAB IC Defect**



**Vertical Line
Source TAB IC Defect**



**Vertical Block
Source TAB IC Defect**



**Horizontal Block
Gate TAB IC Defect**



**Horizontal Block
Gate TAB IC Defect**

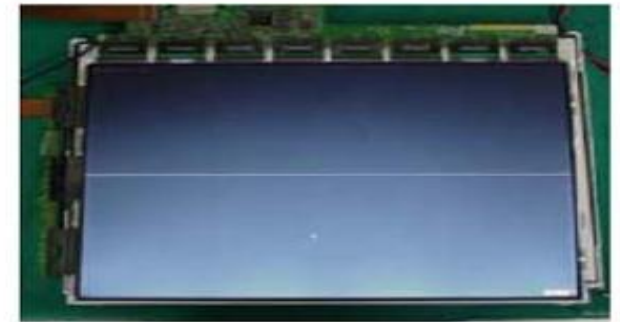

**Horizontal line
Gate TAB IC Defect**

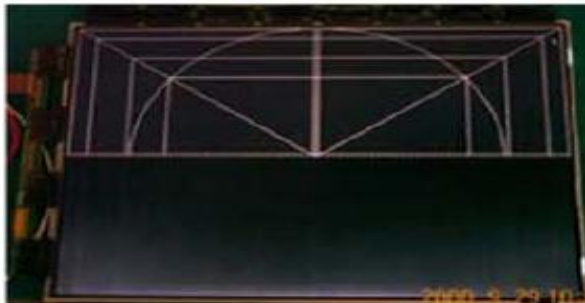

**Horizontal Block
Gate TAB IC Defect**

**Un-repairable Cases
In this case please exchange the module.**

Standard Repair Process Detail Technical Manual

	Error symptom	B. Power error _No power	Established date		
	Content	Check front Power Indicator	Revised date		A17

(Depending on model)

You can simply operate the TV functions, pressing or moving the button.

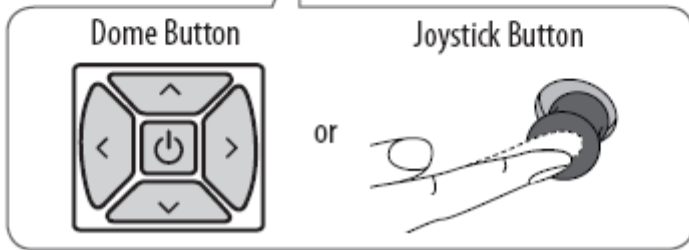
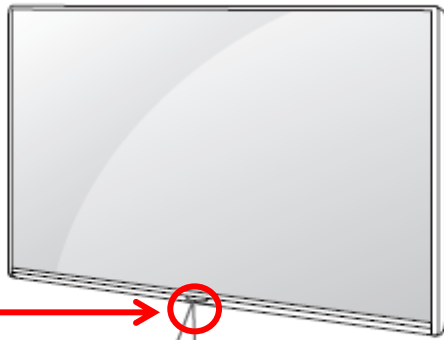

ST-BY condition: On or Off
Power ON condition: Turn Off

Basic functions

		Power On (Press) Power Off (Press and hold)
		Volume Control
		Programmes Control

! NOTE

- When the TV is turned on, place your finger on the button and press it once for a few seconds and release it. All running apps will close, and any recording in progress will stop.

Adjusting the menu

When the TV is turned on, press the button one time. You can adjust the Menu items pressing or moving the buttons.

	Turns the power off.
	Clears on-screen displays and returns to TV viewing.
	Changes the input source.
	Accesses the settings menu.

! NOTE

- When your finger over the joystick button and push it to the up, down, left or right, be careful not to press the joystick button. If you press the joystick button first, you may not be able to adjust the volume level and saved programmes.

Standard Repair Process Detail Technical Manual

	Error symptom	B. Power error _No power	Established date		
	Content	Check power input voltage and ST-BY 3.5V	Revised date		A18

Check the DC 24V, 12V

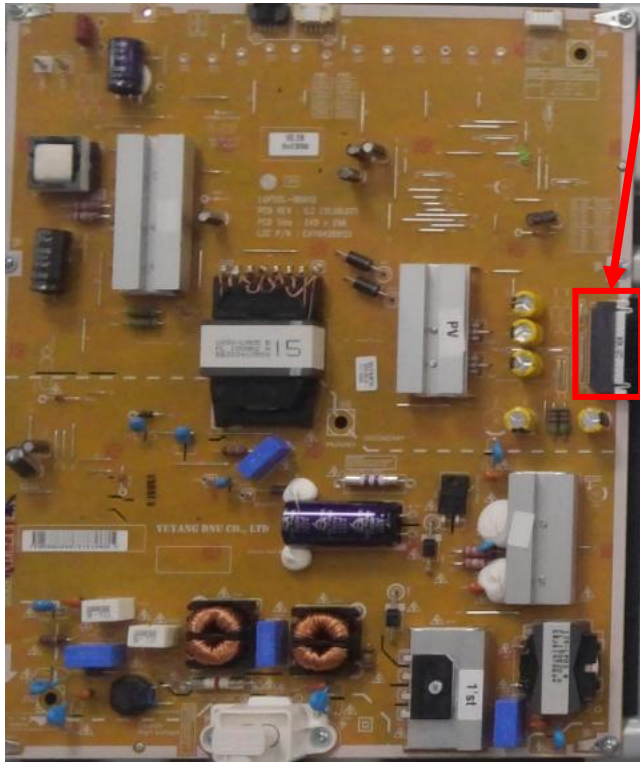

28Pin map (LPB)

1	24V	2	24V
3	24V	4	24V
5	GND	6	GND
7	12V	8	12V
9	GND	10	GND
11	GND	12	GND
13	PWR-On	14	P-DIM2
15	GND	16	12V
17	12V	18	12V
19	24V	20	24V
21	GND	22	GND
23	DRV-ON	24	P-DIM1
25	GND	26	SCLK
27	VSINC	28	SIN

Standard Repair Process Detail Technical Manual

	Error symptom	B. Power error _Off when on, off whiling viewing	Established date		
	Content	POWER OFF MODE checking method	Revised date		A19

<ALL MODELS>

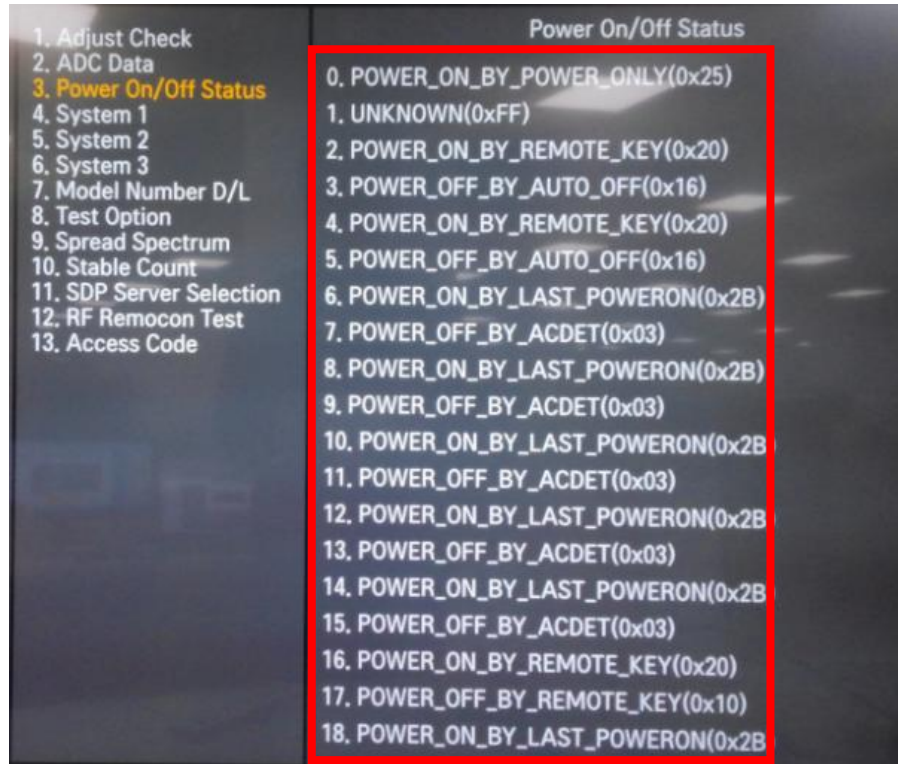

Entry method

1. Press the IN-START button of the remote control for adjustment
2. Check the entry into adjustment item 3`

A19

Standard Repair Process Detail Technical Manual

	Error symptom	C. Audio error_No audio/Normal video	Established date		
	Content	Checking method in menu when there is no audio	Revised date		A20

<ALL MODELS>

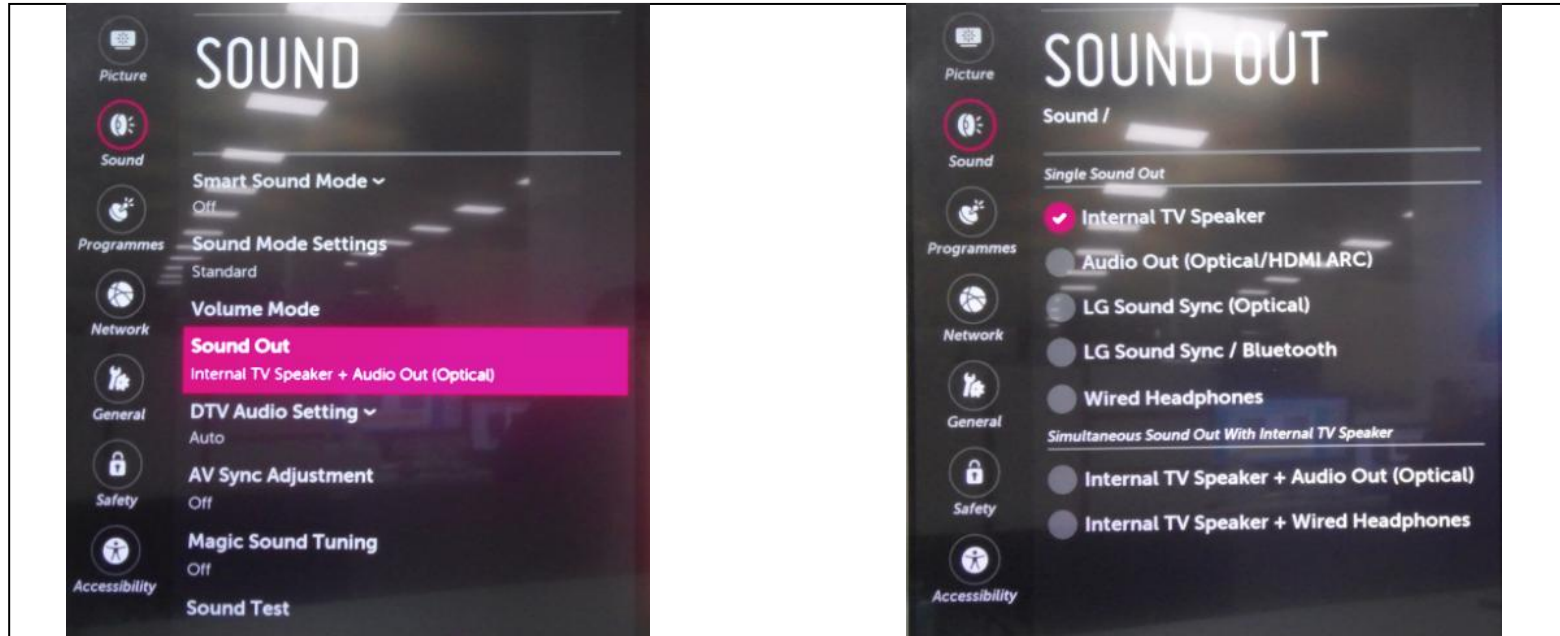

Checking method

1. Press the Setting button on the remote control
2. Select the Sound function of the Menu
3. Select the Sound Out
4. Select TV Speaker

A20

Standard Repair Process Detail Technical Manual

	Error symptom	C. Audio error_No audio/Normal video	Established date		
	Content	Voltage and speaker checking method when there is no audio	Revised date		A21

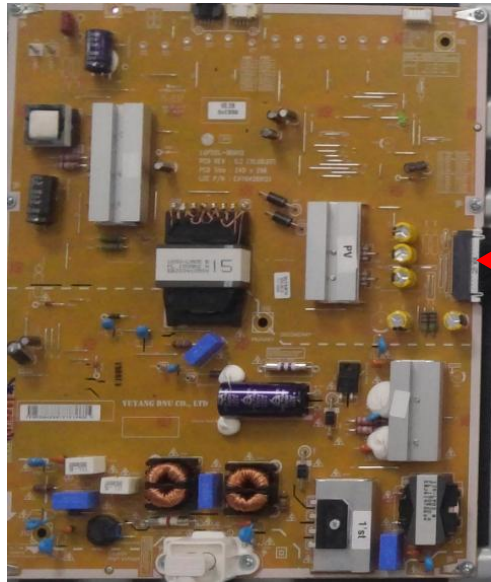

②

1	24V	2	24V
3	24V	4	24V
5	GND	6	GND
7	12V	8	12V
9	GND	10	GND
11	GND	12	GND
13	PWR-On	14	P-DIM2
15	GND	16	12V
17	12V	18	12V
19	24V	20	24V
21	GND	22	GND
23	DRV-ON	24	P-DIM1
25	GND	26	SCLK
27	VSINC	28	SIN

①
Main B/D Side
Pin map reversed

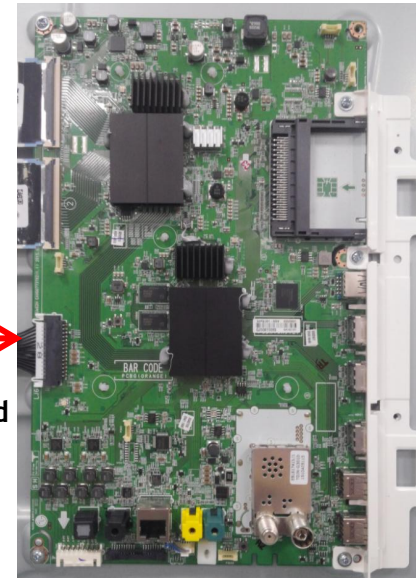

①

③

1	SPK_R_FT	2	SPK_R+_FT
3	SPK_L_FT	4	SPK_L+_FT
5	SPK_R_CT	6	SPK_R+_CT
7	SPK_L_CT	8	SPK_L+_CT

Checking order when there is no audio

① Check the contact condition of cable or connector

② Measure the 24V input voltage supplied from Power Board
(If there is no input voltage, remove and check the connector)

Standard Repair Process Detail Technical Manual

	Error symptom	D. Function error	Established date		
	Content	Remote control operation checking method	Revised date		A22

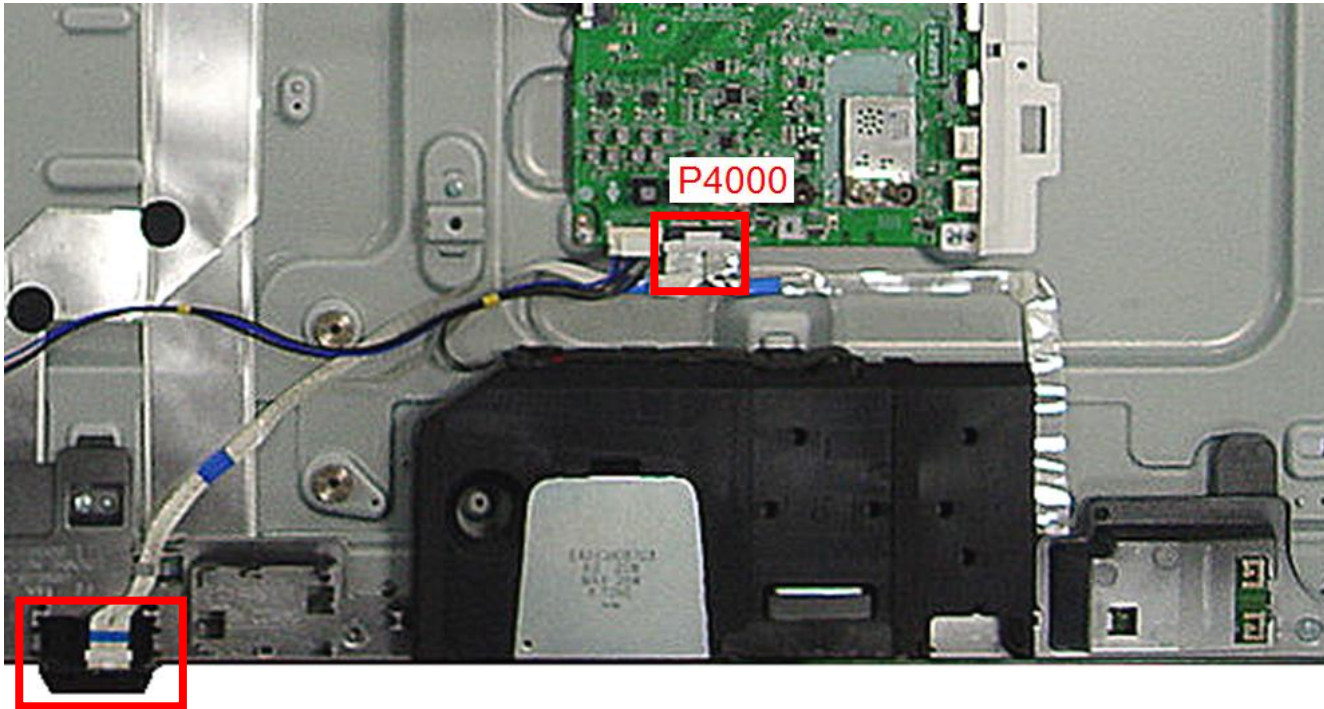

P4000 Pin map			
1	+3.5V_WIFI	12	EYE_SCL
2	WIFI_DM	13	EYE_SDA
3	WIFI_DP	14	GND
4	GND	15	IR
5	WOL_Power_On	16	LED_R
6	3D_Sync	17	GND
7	BT_Reset	18	+3.5_ST
8	GND	19	KEY2
		20	KEY1
		21	GND

Checking order

1. Check IR cable condition between IR & Main board.
2. Check the st-by 3.5V on the pin 18

Standard Repair Process Detail Technical Manual

	Error symptom	D. Function error	Established date		
	Content	Motion Remote, Wi-Fi operation checking method	Revised date		A23

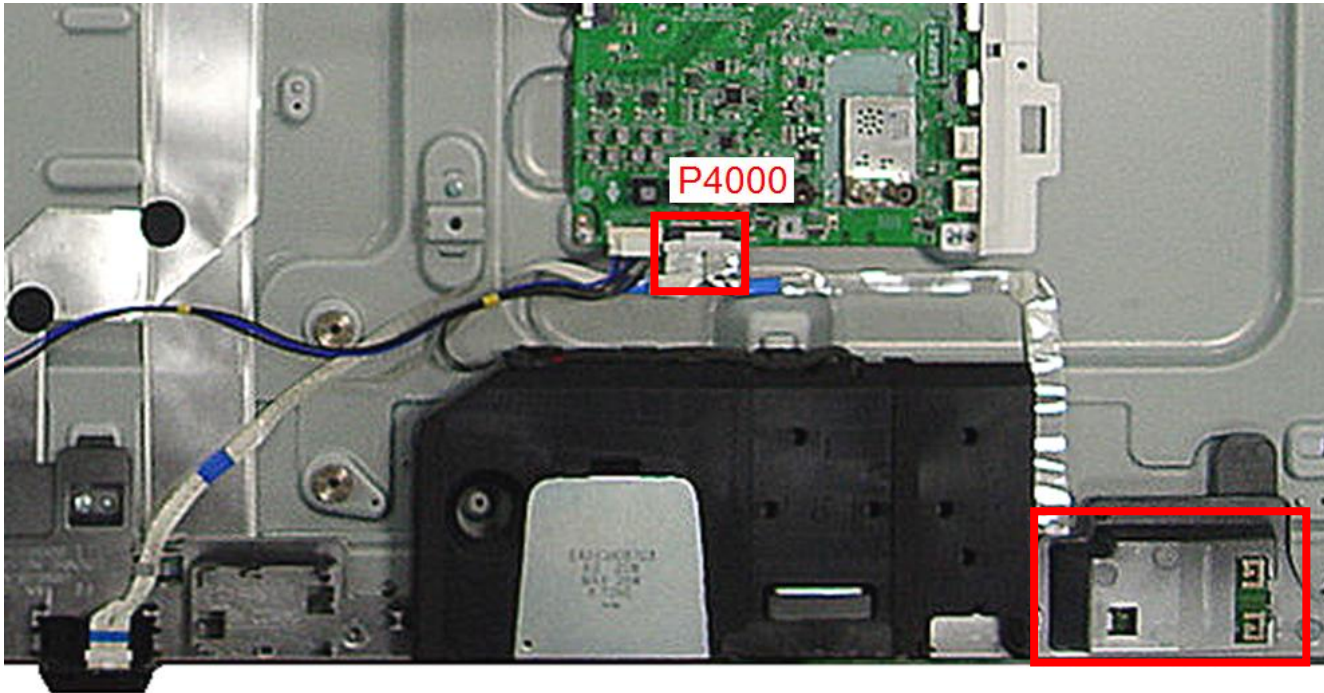

P4000 Pin map			
1	+3.5V_WIFI	12	EYE_SCL
2	WIFI_DM	13	EYE_SDA
3	WIFI_DP	14	GND
4	GND	15	IR
5	WOL_Power_On	16	LED_R
6	3D_Sync	17	GND
7	BT_Reset	18	+3.5_ST
8	GND	19	KEY2
		20	KEY1
		21	GND

Checking order

1. Check Motion cable condition between Motion assy & Main board.
2. Check the 3.3V on the pin 1.