



SERVICE MANUAL

MODEL: BPM26



# NETWORK 3D BLU-RAY DISC / DVD PLAYER

## SERVICE MANUAL

**MODEL: BPM26**

### CAUTION

BEFORE SERVICING THE UNIT, READ THE "SAFETY PRECAUTIONS" IN THIS MANUAL.

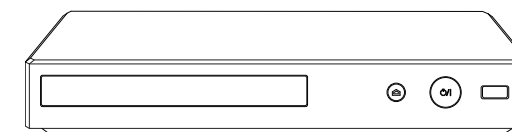

P/NO : AFN78082583

MARCH, 2021

"Any reproduction, duplication, distribution (including by way of email, facsimile or other electronic means), publication, modification, copying or transmission of this Service Manual is STRICTLY PROHIBITED unless you have obtained the prior written consent of the LG Electronics entity from which you received this Service Manual. The material covered by this prohibition includes, without limitation, any text, graphics or logos in this Service Manual."

LG

Copyright © 2021 LG Electronics Inc. All rights reserved.  
Only for training and service purposes.

## **CONTENTS**

**SECTION 1 .....SUMMARY**

**SECTION 2 .....CABINET & MAIN CHASSIS**

**SECTION 3 .....ELECTRICAL**

**SECTION 4 .....MT8553 / MT8563 F/E LOADER PART**

# SECTION 1

## SUMMARY

### CONTENTS

<b>PRODUCT SAFETY SERVICING GUIDELINES FOR BLU-RAY DISC / DVD PLAYER PRODUCTS .....</b>	<b>1-3</b>
<b>SERVICING PRECAUTIONS .....</b>	<b>1-4</b>
• GENERAL SERVICING PRECAUTIONS	
• INSULATION CHECKING PRODEDURE	
• ELECTROSTATICALLY SENSITIVE (ES) DEVICES	
<b>FIRMWARE UPDATE GUIDE .....</b>	<b>1-5</b>
<b>SPECIFICATIONS .....</b>	<b>1-8</b>

# PRODUCT SAFETY SERVICING GUIDELINES FOR BLU-RAY DISC / DVD PLAYER PRODUCTS

## IMPORTANT SAFETY NOTICE

This manual was prepared for use only by properly trained audio-video service technicians.

When servicing this product, under no circumstances should the original design be modified or altered without permission from LG Corporation. All components should be replaced only with types identical to those in the original circuit and their physical location, wiring and lead dress must conform to original layout upon completion of repairs.

Special components are also used to prevent x-radiation, shock and fire hazard. These components are indicated by the letter "x" included in their component designators and are required to maintain safe performance. No deviations are allowed without prior approval by LG Corporation.

Circuit diagrams may occasionally differ from the actual circuit used. This way, implementation of the latest safety and performance improvement changes into the set is not delayed until the new service literature is printed.

**CAUTION** : Do not attempt to modify this product in any way. Never perform customized installations without manufacturer's approval. Unauthorized modifications will not only void the warranty, but may lead to property damage or user injury.

Service work should be performed only after you are thoroughly familiar with these safety checks and servicing guidelines.

## GRAPHIC SYMBOLS



The exclamation point within an equilateral triangle is intended to alert the service personnel to important safety information in the service literature.



The lightning flash with arrowhead symbol within an equilateral triangle is intended to alert the service personnel to the presence of noninsulated "dangerous voltage" that may be of sufficient magnitude to constitute a risk of electric shock.



The pictorial representation of a fuse and its rating within an equilateral triangle is intended to convey to the service personnel the following fuse replacement caution notice:

**CAUTION** : FOR CONTINUED PROTECTION AGAINST RISK OF FIRE, REPLACE ALL FUSES WITH THE SAME TYPE AND RATING AS MARKED NEAR EACH FUSE.

## SERVICE INFORMATION

While servicing, use an isolation transformer for protection from AC line shock. After the original service problem has been corrected, make a check of the following:

### FIRE AND SHOCK HAZARD

1. Be sure that all components are positioned to avoid a possibility of adjacent component shorts. This is especially important on items transported to and from the repair shop.
2. Verify that all protective devices such as insulators, barriers, covers, shields, strain reliefs, power supply cords, and other hardware have been reinstalled per the original design. Be sure that the safety purpose of the polarized line plug has not been defeated.
3. Soldering must be inspected to discover possible cold solder joints, solder splashes, or sharp solder points. Be certain to remove all loose foreign particles.
4. Check for physical evidence of damage or deterioration to parts and components, for frayed leads or damaged insulation (including the AC cord), and replace if necessary.
5. No lead or component should touch a high current device or a resistor rated at 1 watt or more. Lead tension around protruding metal surfaces must be avoided.
6. After reassembly of the set, always perform an AC leakage test on all exposed metallic parts of the cabinet (the channel selector knobs, antenna terminals, handle and screws) to be sure that set is safe to operate without danger of electrical shock. **DO NOT USE A LINE ISOLATION TRANSFORMER DURING THIS TEST.** Use an AC voltmeter having 5000 ohms per volt or more sensitivity in the following manner: Connect a 1500 ohm, 10 watt resistor, paralleled by a .15 mfd 150V AC type capacitor between a known good earth ground water pipe, conduit, etc.) and the exposed metallic parts, one at a time. Measure the AC voltage across the combination of 1500 ohm resistor and .15 mfd capacitor. Reverse the AC plug by using a non-polarized adaptor and repeat AC voltage measurements for each exposed metallic part. Voltage measured must not exceed 0.75 volts RMS. This corresponds to 0.5 milliamp AC. Any value exceeding this limit constitutes a potential shock hazard and must be corrected immediately.

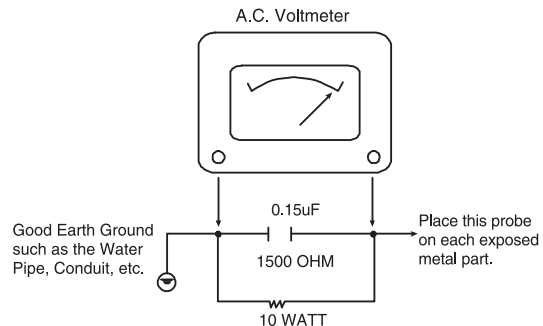

## TIPS ON PROPER INSTALLATION

1. Never install any receiver in a closed-in recess, cubbyhole, or closely fitting shelf space over, or close to, a heat duct, or in the path of heated air flow.
2. Avoid conditions of high humidity such as: outdoor patio installations where dew is a factor, near steam radiators where steam leakage is a factor, etc.
3. Avoid placement where draperies may obstruct venting. The customer should also avoid the use of decorative scarves or other coverings that might obstruct ventilation.
4. Wall- and shelf-mounted installations using a commercial mounting kit must follow the factory-approved mounting instructions. A product mounted to a shelf or platform must retain its original feet (or the equivalent thickness in spacers) to provide adequate air flow across the bottom. Bolts or screws used for fasteners must not touch any parts or wiring. Perform leakage tests on customized installations.
5. Caution customers against mounting a product on a sloping shelf or in a tilted position, unless the receiver is properly secured.
6. A product on a roll-about cart should be stable in its mounting to the cart. Caution the customer on the hazards of trying to roll a cart with small casters across thresholds or deep pile carpets.
7. Caution customers against using extension cords. Explain that a forest of extensions, sprouting from a single outlet, can lead to disastrous consequences to home and family.

# SERVICING PRECAUTIONS

**CAUTION:** Before servicing the BLU-RAY DISC / DVD PLAYER covered by this service data and its supplements and addends, read and follow the SAFETY PRECAUTIONS.

**NOTE:** if unforeseen circumstances create conflict between the following servicing precautions and any of the safety precautions in this publications, always follow the safety precautions.

Remember Safety First :

## General Servicing Precautions

1. Always unplug the BLU-RAY DISC / DVD PLAYER AC power cord from the AC power source before:

- (1) Removing or reinstalling any component, circuit board, module, or any other assembly.
- (2) Disconnecting or reconnecting any internal electrical plug or other electrical connection.
- (3) Connecting a test substitute in parallel with an electrolytic capacitor.

**Caution :** A wrong part substitution or incorrect polarity installation of electrolytic capacitors may result in an explosion hazard.

2. Do not spray chemicals on or near this BLU-RAY DISC / DVD PLAYER or any of its assemblies.

3. Unless specified otherwise in this service data, clean electrical contacts by applying an appropriate contact cleaning solution to the contacts with a pipe cleaner, cotton-tipped swab, or comparable soft applicator.

Unless specified otherwise in this service data, lubrication of contacts is not required.

4. Do not defeat any plug/socket B+ voltage interlocks with which instruments covered by this service manual might be equipped.

5. Do not apply AC power to this BLU-RAY DISC / DVD PLAYER and / or any of its electrical assemblies unless all solid state device heat sinks are correctly installed.

6. Always connect the test instrument ground lead to an appropriate ground before connecting the test instrument positive lead. Always remove the test instrument ground lead last.

## Insulation Checking Procedure

Disconnect the attachment plug from the AC outlet and turn the power on. Connect an insulation resistance meter (500V) to the blades of the attachment plug. The insulation resistance between each blade of the attachment plug and accessible conductive parts (Note 1) should be more than 1Mohm.

**Note 1 :** Accessible Conductive Parts include Metal panels, Input terminals, Earphone jacks, etc.

## Electrostatically Sensitive (ES) Devices

Some semiconductor (solid state) devices can be damaged easily by static electricity. Such components commonly are called Electrostatically Sensitive (ES) Devices. Examples of typical ES devices are integrated circuits and some field effect transistors and semiconductor chip components.

The following techniques should be used to help reduce the incidence of component damage caused by static electricity.

1. Immediately before handling any semiconductor component or semiconductor-equipped assembly, drain off any electrostatic charge on your body by touching a known earth ground. Alternatively, obtain and wear a commercially available discharging wrist strap device, which should be removed for potential shock reasons prior to applying power to the unit under test.

2. After removing an electrical assembly equipped with ES devices, place the assembly on a conductive surface such as aluminum foil, to prevent electrostatic charge buildup or exposure of the assembly.

3. Use only a grounded-tip soldering iron to solder or unsolder ES devices.

4. Use only an anti-static solder removal device. Some solder removal devices not classified as "anti-static" can generate electrical charges sufficient to damage ES devices.

5. Do not use freon-propelled chemicals. These can generate an electrical charge sufficient to damage ES devices.

6. Do not remove a replacement ES device from its protective package until immediately before you are ready to install it. (Most replacement ES devices are packaged with leads electrically shorted together by conductive foam, aluminum foil, or comparable conductive material).

7. Immediately before removing the protective material from the leads of a replacement ES device, touch the protective material to the chassis or circuit assembly into which the device will be installed.

**Caution:** Be sure no power is applied to the chassis or circuit, and observe all other safety precautions.

8. Minimize bodily motions when handling unpackaged replacement ES devices. (Normally harmless motion such as the brushing together of your clothes fabric or the lifting of your foot from a carpeted floor can generate static electricity sufficient to damage an ES device.)

# FIRMWARE UPDATE GUIDE

## 1. COPY AN UPDATE FILE TO A MEDIA (USB OR CD-ROM)

Update File Name: LG\_BD\_8100M60.ROM

- 1) An update file have to be copied onto the root of file system.
- 2) USB and CD-ROM are able to use firmware update.

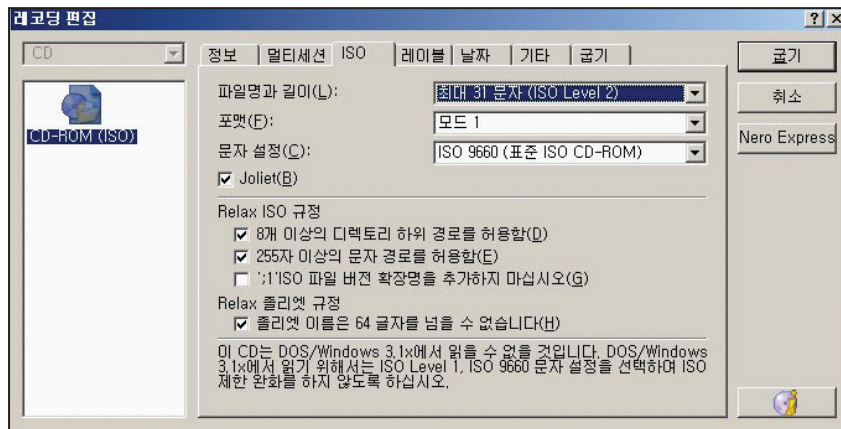

< Example: Nero Burning Rom >

# FIRMWARE UPDATE GUIDE

## 2. UPDATE FIRMWARE

- 1) Insert USB or CD-ROM which has an update file.
- 2) OSD responds to the insertion event.
- 3) OSD is shown as below.

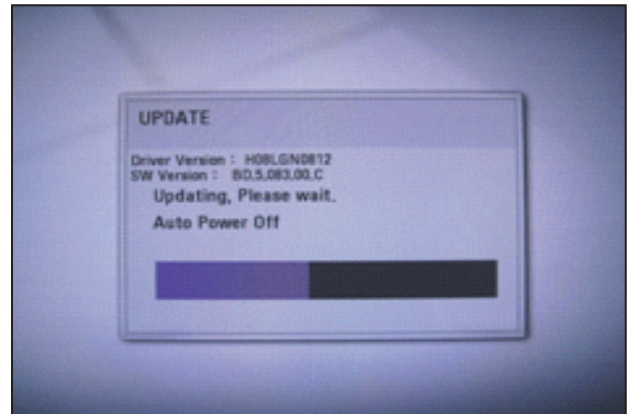
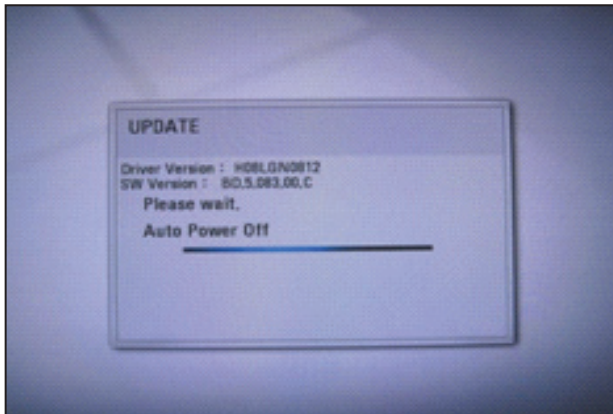
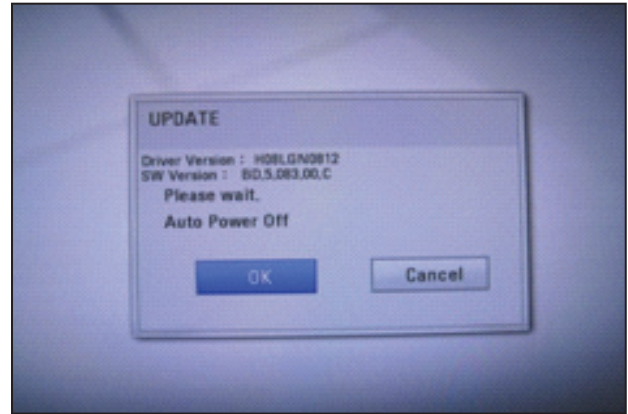

< Firmware Update OSD >

### OSD contents:

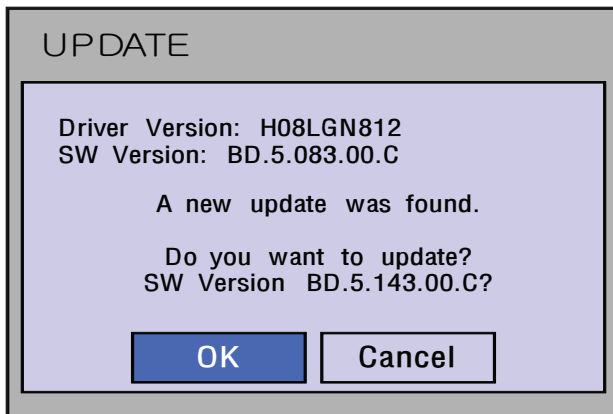

# FIRMWARE UPDATE GUIDE

## 3. DURING UPDATING

- 1) Progressive bar is shown on the update time repeatedly.
- 2) Tray is opened.

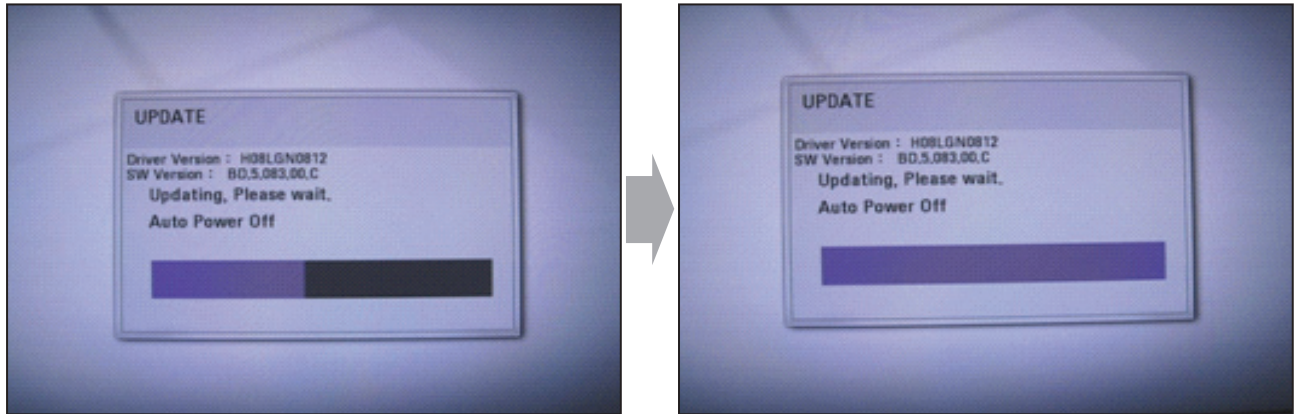

## 4. AFTER UPDATE COMPLETE

- 1) Power off / on automatically after update complete.
- 2) Tray will be closed.



# SPECIFICATIONS

## • GENERAL

AC adapter	Model: WA-12M12FU Manufacturer: Asian Power Devices Inc. Input: 100-240 V~, 50-60 Hz 0.5 A Max. Output: 12 V $\overline{=}$ 1 A
Dimensions (W x H x D)	Approx. 270 mm x 43 mm x 195 mm (10.62 x 1.69 x 7.68 Inches)
Net Weight (Approx.)	0.87 kg (1.92 lbs)
Operating temperature	5 °C to 35 °C
Operating humidity	5 % to 90 %

## • OUTPUTS

HDMI OUT (video/audio)	19 pin (Type A, HDMI™ Connector)
DIGITAL AUDIO OUT (COAXIAL) - (Option)	0.5 V (p-p), 75 $\Omega$ , RCA jack x 1

## • SYSTEM

Laser	Semiconductor laser
wavelength	405 nm / 650 nm
Signal system	Standard PAL/NTSC Color TV system
LAN port - (Option)	Ethernet jack x 1, 10BASE-T / 100BASE-TX
Wireless LAN (internal antenna) - (Option)	Integrated IEEE 802.11b/g/n (2.4 GHz bands) wireless networking access
Bus Power Supply (USB)	DC 5 V $\overline{=}$ 500 mA

**Note :** Design and specifications are subject to change prior notice.

# SECTION 2

## CABINET & MAIN CHASSIS

### CONTENTS

**EXPLODED VIEWS** ..... 2-2

1. CABINET AND MAIN FRAME SECTION ..... 2-2

2. PACKING ACCESSORY SECTION ..... 2-4

# EXPLODED VIEWS

## 1. CABINET AND MAIN FRAME SECTION

5

4

3

2

1

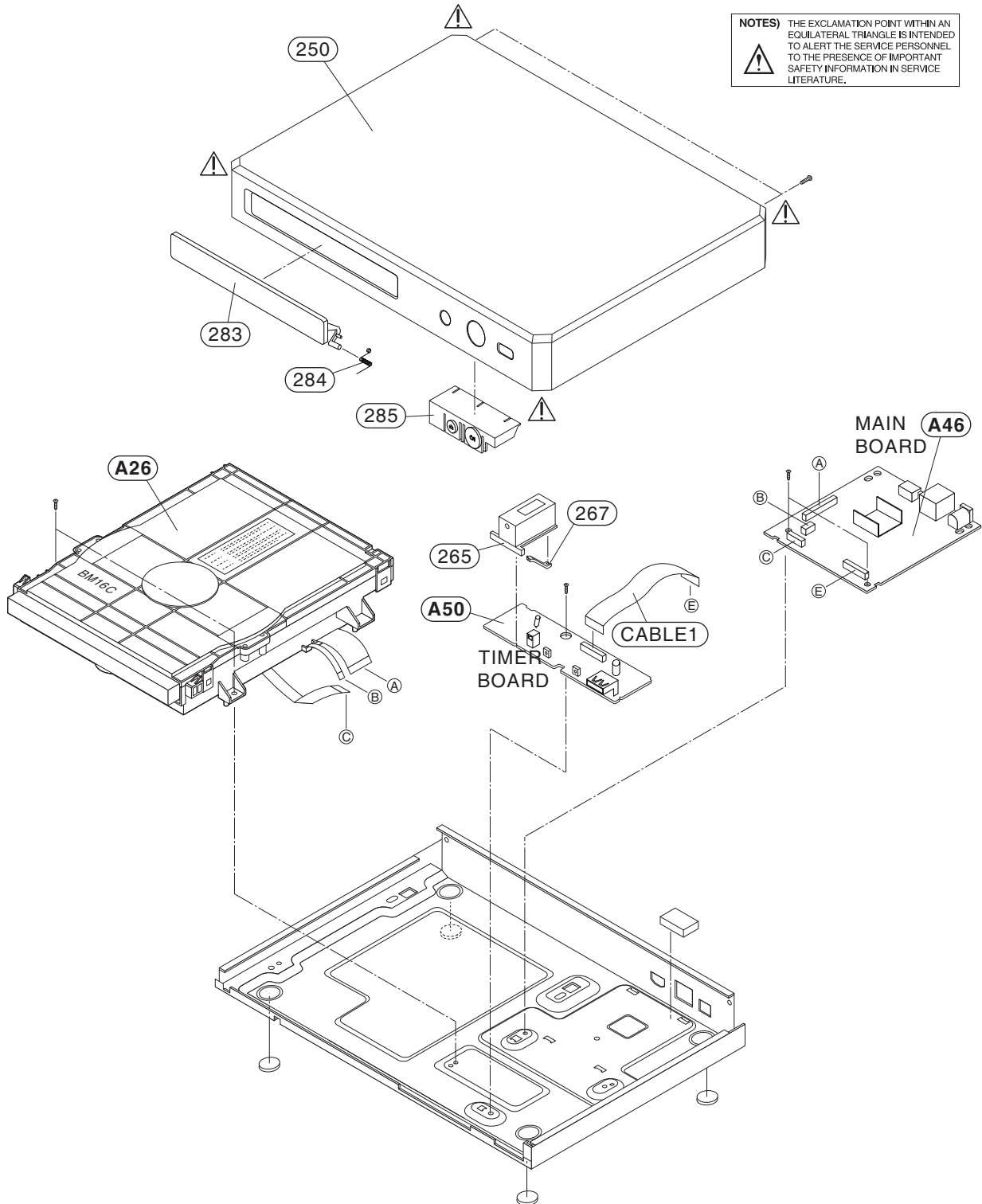

A

B

C

D

• Cabinet and main frame parts list

S	AL	LOCA. NO.	PART NO.	DESCRIPTION	SPECIFICATION	REMARKS
<b>Assembly parts</b>						
		A26	EAZ61703201	Deck Assembly,DVD	DECK/MECHA [D6BP3]-BM16D.SN12	
		A46	EBT64453715	LFS Total PCB Assembly	55 53 00 00 09 50 8F 42, D5 07	
		A50	EBR79467911	PCB Assembly,Timer/Key	BP550 Timer Dot LED PCB ASSEMB	
<b>Individual parts</b>						
		250	MBN63844601	Case	MOLD ABS BP550 MOLD BP550 Cove	
		265	MEG64120301	Holder	MOLD HIPS BD Player BP550 MOLD	
		267	MFB63753202	Lens	MOLD ABS BD Player BP550 Lens	
		283	MCV63273707	Door	MOLD ABS BD Player BPM36 MOLD	
		284	MHY63124701	Spring	EXTRUSION SWC COIL RH735 Torsi	
		285	MBG65423802	Button	MOLD ABS BD Player BPM36 MOLD	
<b>Cables</b>						
		CABLE1	EAD62097102	Cable,FFC	12P_1.0_105mm 105MM 1.00MM 12P	
	OR	CABLE1	EAD63786001	Cable,FFC	12P100C-H02-1F01A-N-110-110-0-	

## 2. PACKING ACCESSORY SECTION

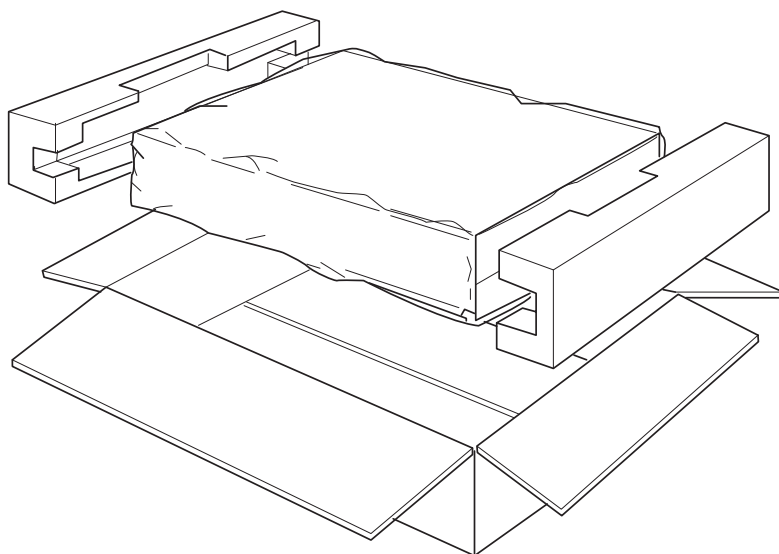
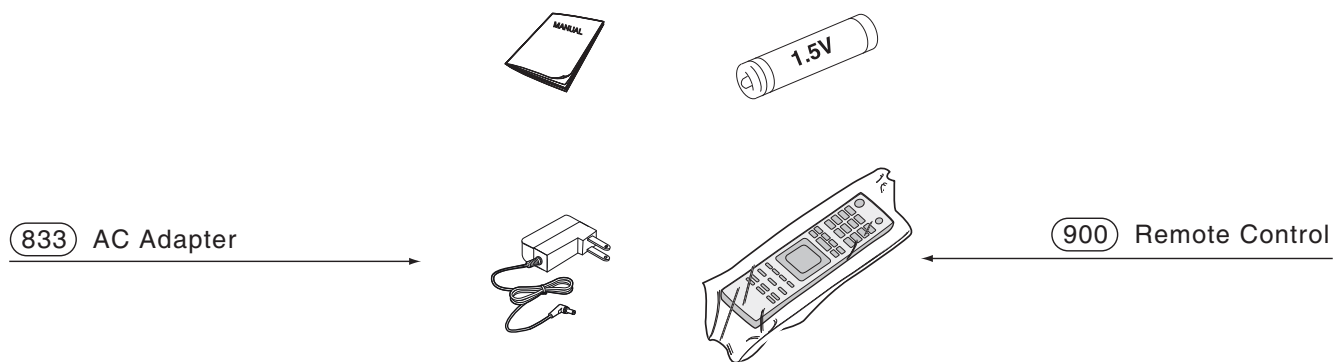

• **Packing accessory parts list**

S	AL	LOCA. NO.	PART NO.	DESCRIPTION	SPECIFICATION	REMARKS
△		833	EAY62851514	Adapters	WA-12M12FU-GVAA 100-120Vac 12V	
		900	AKB75135401	Remote Controller Assembly	U3-1 BP350 FCC	

# MEMO

A series of horizontal dotted lines for writing.

# SECTION 3 ELECTRICAL

## CONTENTS

<b>DIGITAL DISPLAY &amp; MEDIA TRAINING MASTER</b> .....	<b>3-2</b>
1. DISTORTED PICTURE.....	3-2
2. NO PICTURE .....	3-7
3. PICTURE COLOR.....	3-12
4. NOISE/AUDIO PROBLEMS.....	3-14
5. MISCELLANEOUS.....	3-17
6. BLU-RAY PLAYER .....	3-26
<b>ONE POINT REPAIR GUIDE</b> .....	<b>3-27</b>
1. NO POWER PROBLEM .....	3-27
2. LED DOESN'T LIGHT ON .....	3-28
3. NO BOOTING WHEN YOU TURN THE UNIT ON.....	3-29
4. BAD HDMI VIDEO / AUDIO OUTPUT.....	3-38
5. WIRED NETWORK CONNECTION ERROR - (OPTION PART).....	3-39
6. WIRELESS NETWORK CONNECTION ERROR - (OPTION PART).....	3-40
<b>ELECTRICAL TROUBLESHOOTING GUIDE</b> .....	<b>3-41</b>
1. POWER SUPPLY ON MAIN BOARD .....	3-41
2. SYSTEM PART .....	3-43
3. NO HDMI OUTPUT.....	3-45
<b>WAVEFORMS OF MAJOR CHECK POINT</b> .....	<b>3-46</b>
1. SYSTEM PART - 1 .....	3-46
2. SYSTEM PART - 2 (SYSTEM MEMORY).....	3-47
3. HDMI PART .....	3-48
<b>WIRING DIAGRAMS</b> .....	<b>3-49</b>
<b>BLOCK DIAGRAM</b> .....	<b>3-50</b>
<b>CIRCUIT VOLTAGE CHART</b> .....	<b>3-51</b>
<b>PRINTED CIRCUIT BOARD DIAGRAMS</b> .....	<b>3-53</b>
1. MAIN P.C.BOARD .....	3-53
2. TIMER P.C. BOARD .....	3-53



# DIGITAL DISPLAY & MEDIA TRAINING MASTER

**Objective:** To provide clear and concise guidelines for customer service agents to handle calls on box goods calls.

## 1. DISTORTED PICTURE

### 1-1. Lines on Picture

Distorted picture refers to the customer getting video, but there is a problem with the video.

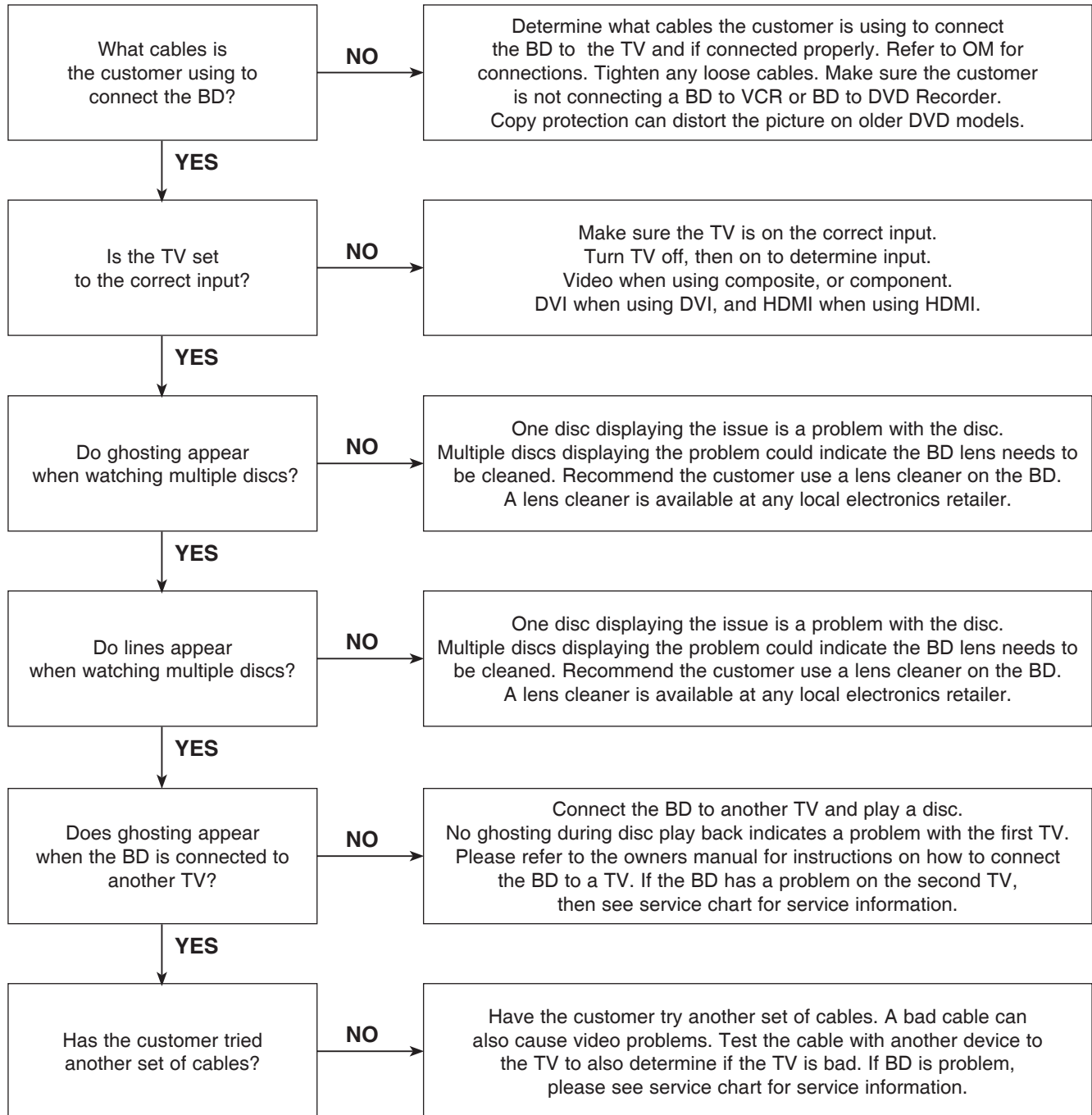

# DIGITAL DISPLAY & MEDIA TRAINING MASTER

## 1-2. Ghost Picture

Distorted picture refers to the customer getting video, but there is a problem with the video.

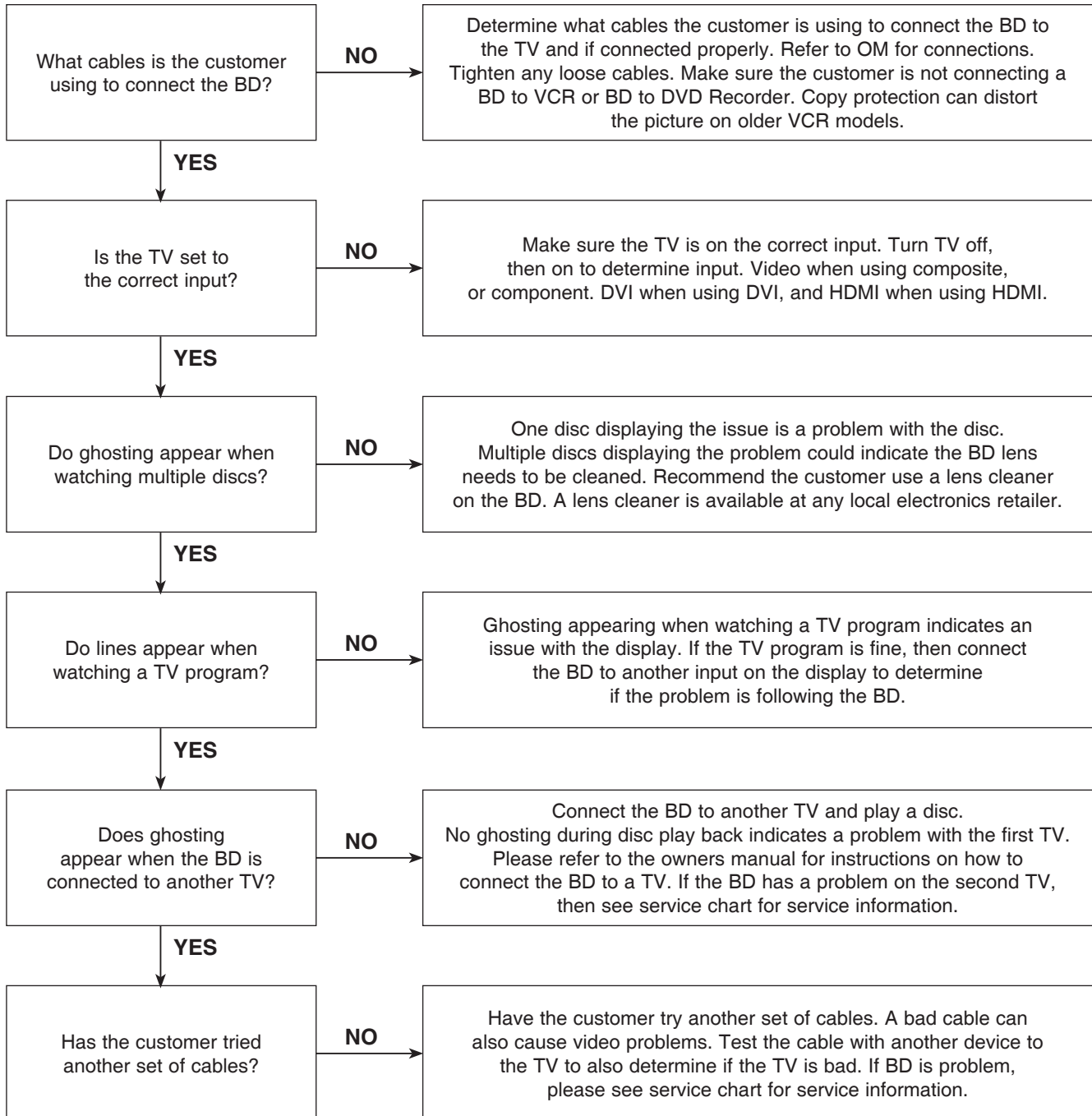

# DIGITAL DISPLAY & MEDIA TRAINING MASTER

## 1-3. Rolling Picture

Distorted picture refers to the customer getting video, but there is a problem with the video.

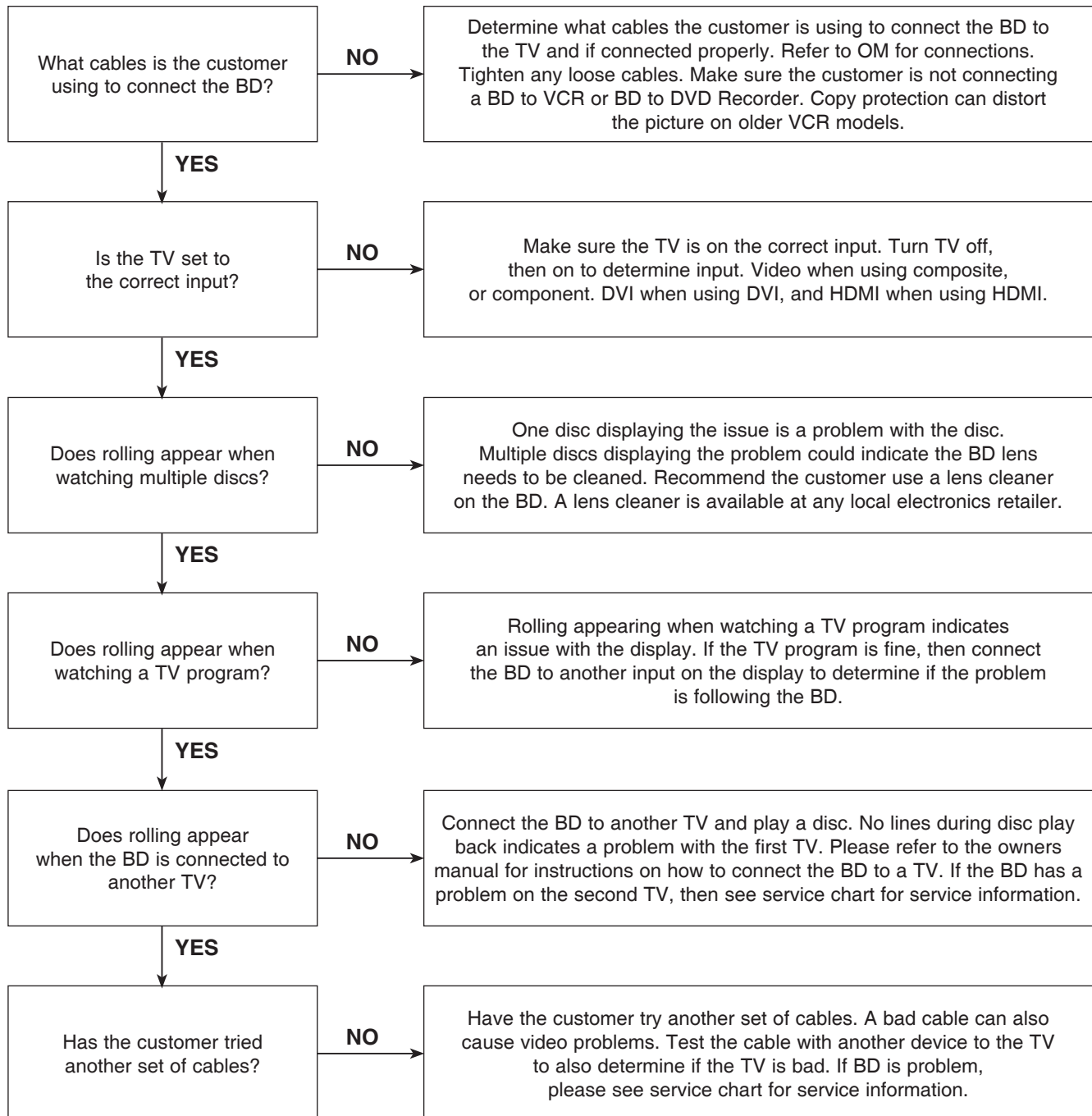

# DIGITAL DISPLAY & MEDIA TRAINING MASTER

## 1-4. Shaky Picture

Distorted picture refers to the customer getting video, but there is a problem with the video.

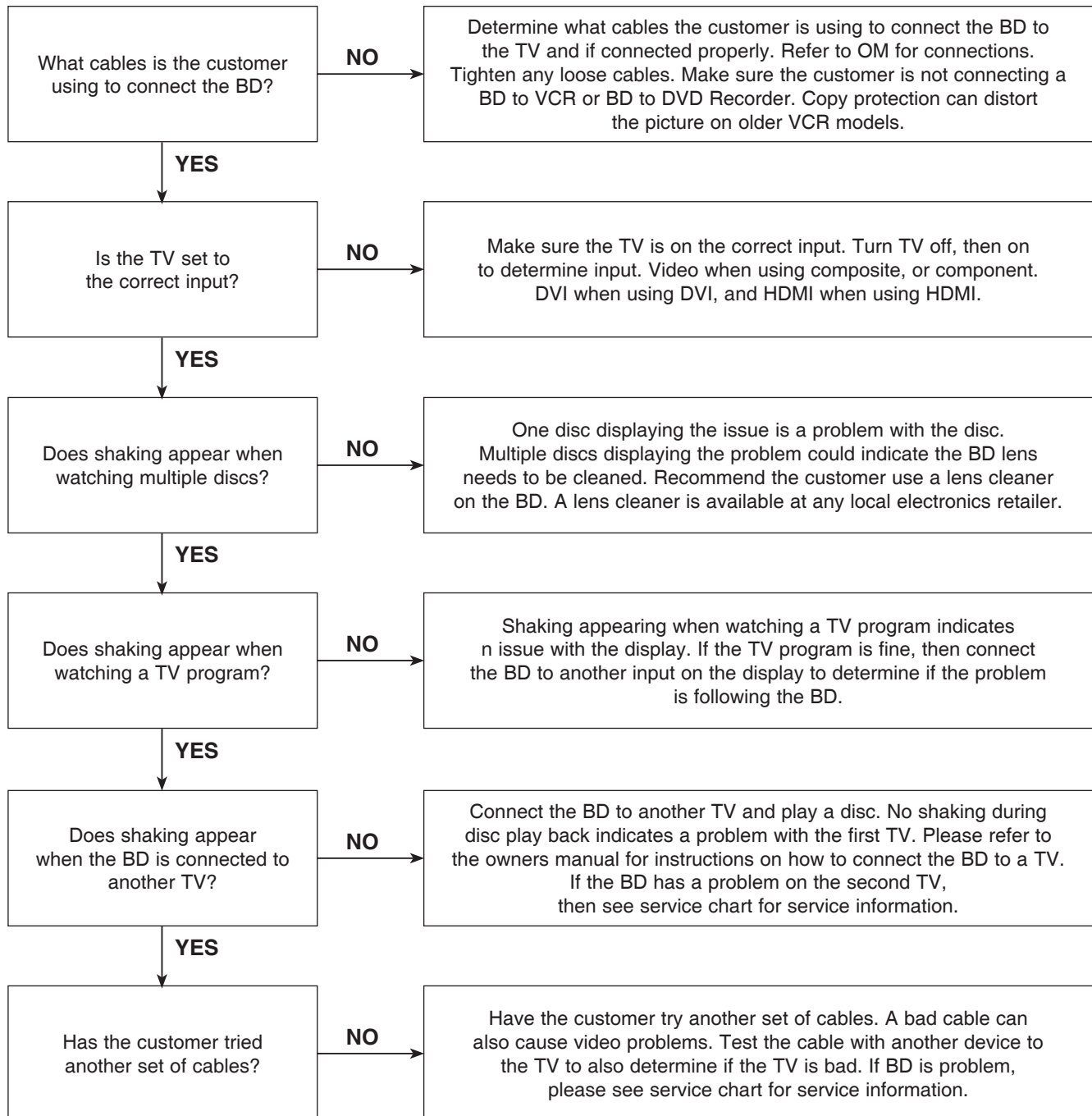

# DIGITAL DISPLAY & MEDIA TRAINING MASTER

## 1-5. Blurry Picture

Distorted picture refers to the customer getting video, but there is a problem with the video.

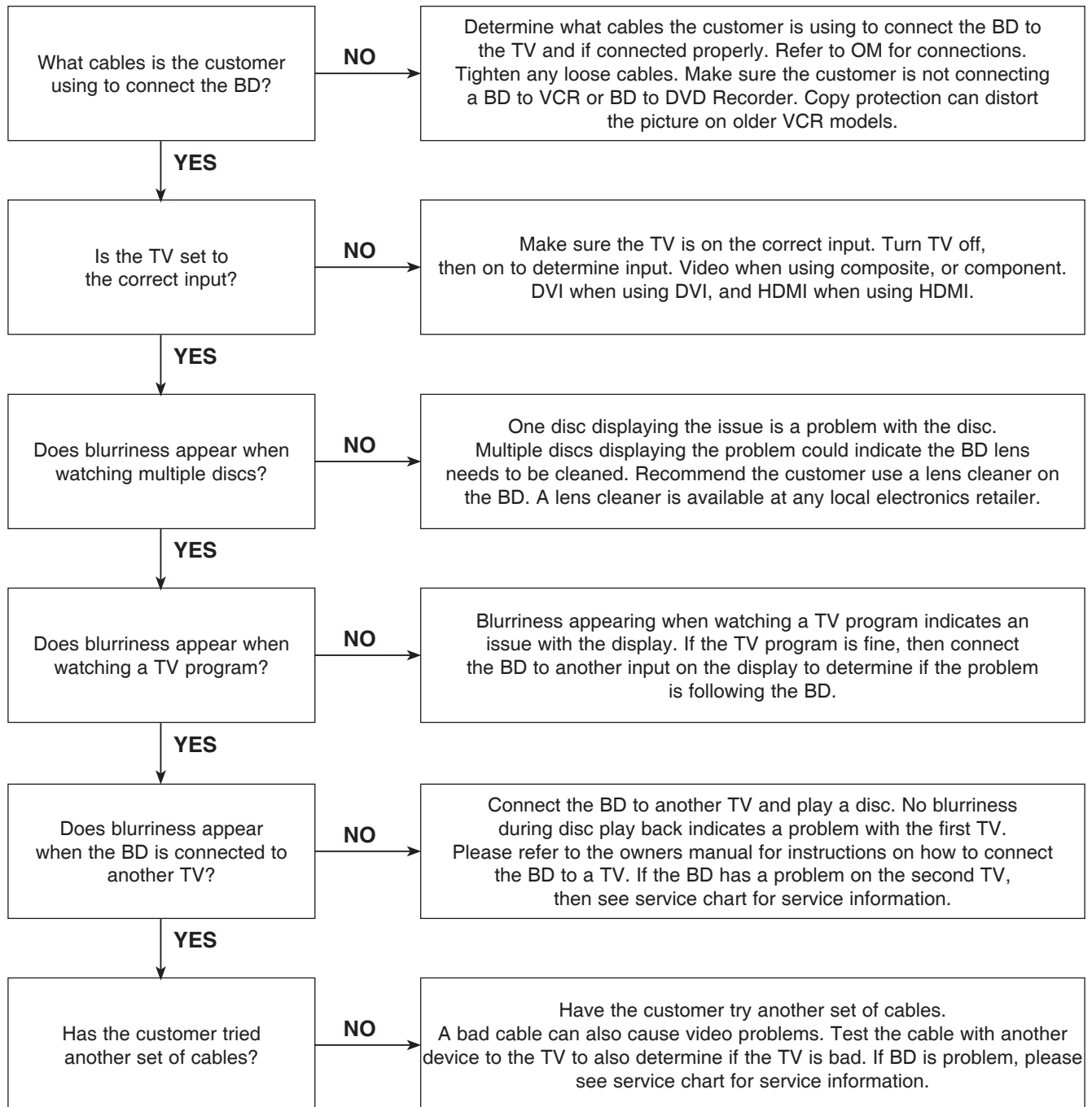

# DIGITAL DISPLAY & MEDIA TRAINING MASTER

## 2. NO PICTURE

### 2-1. Black Screen

The entire screen is black.

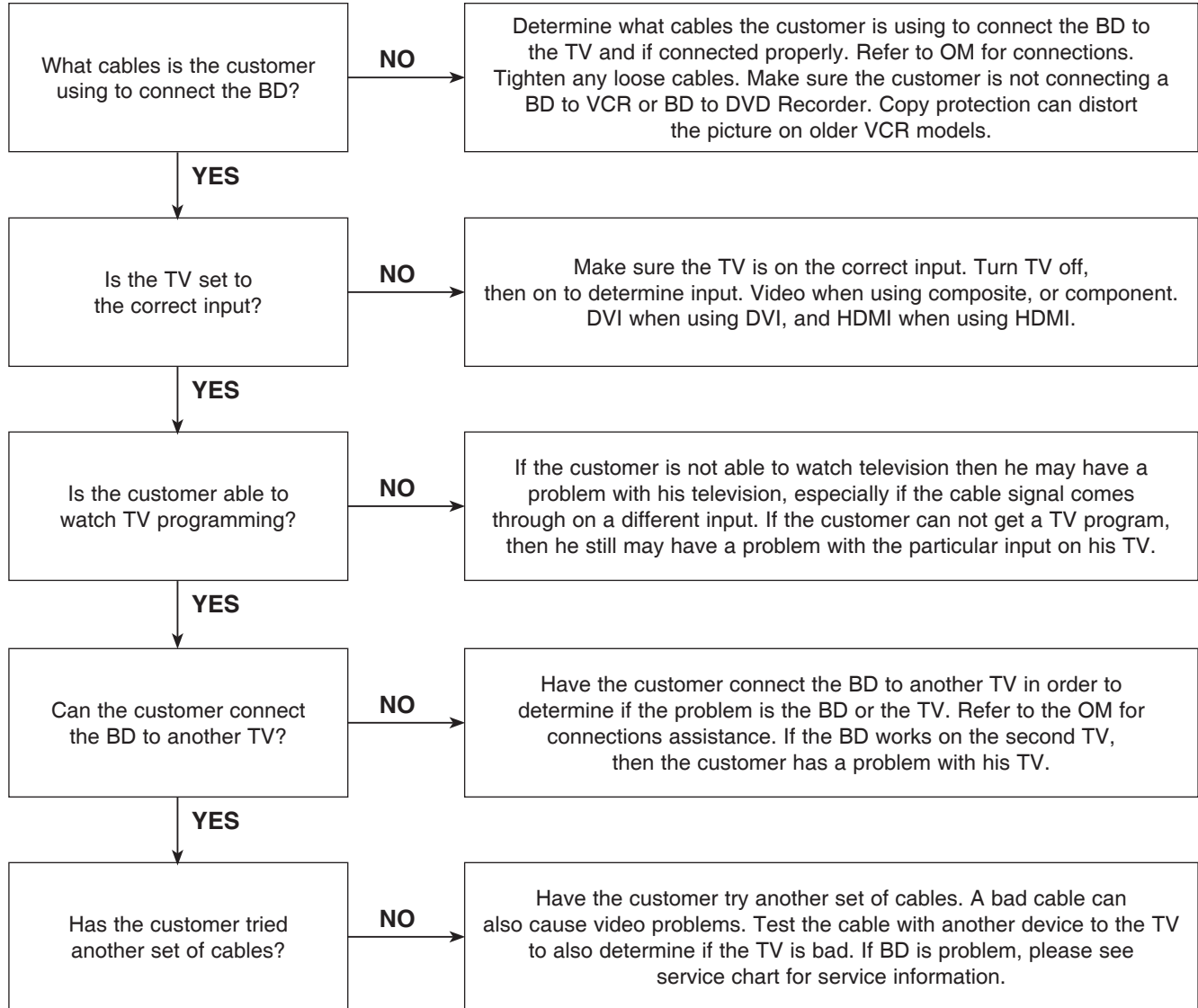

# DIGITAL DISPLAY & MEDIA TRAINING MASTER

## 2-2. Blue Screen

The entire screen is a solid blue color.

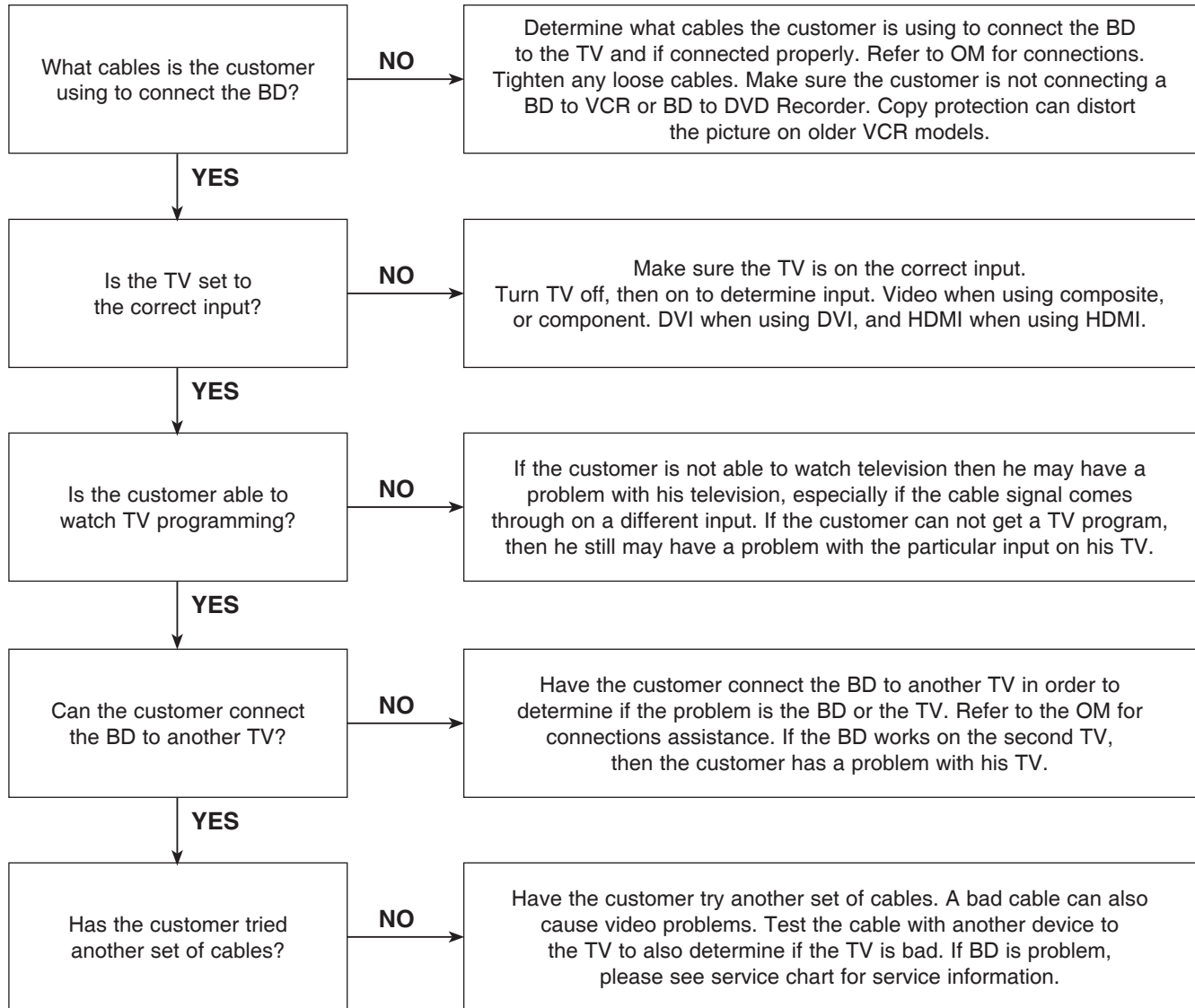

# DIGITAL DISPLAY & MEDIA TRAINING MASTER

## 2-3. Snowy Screen

A snowy picture is when black and white dots are all over the screen.

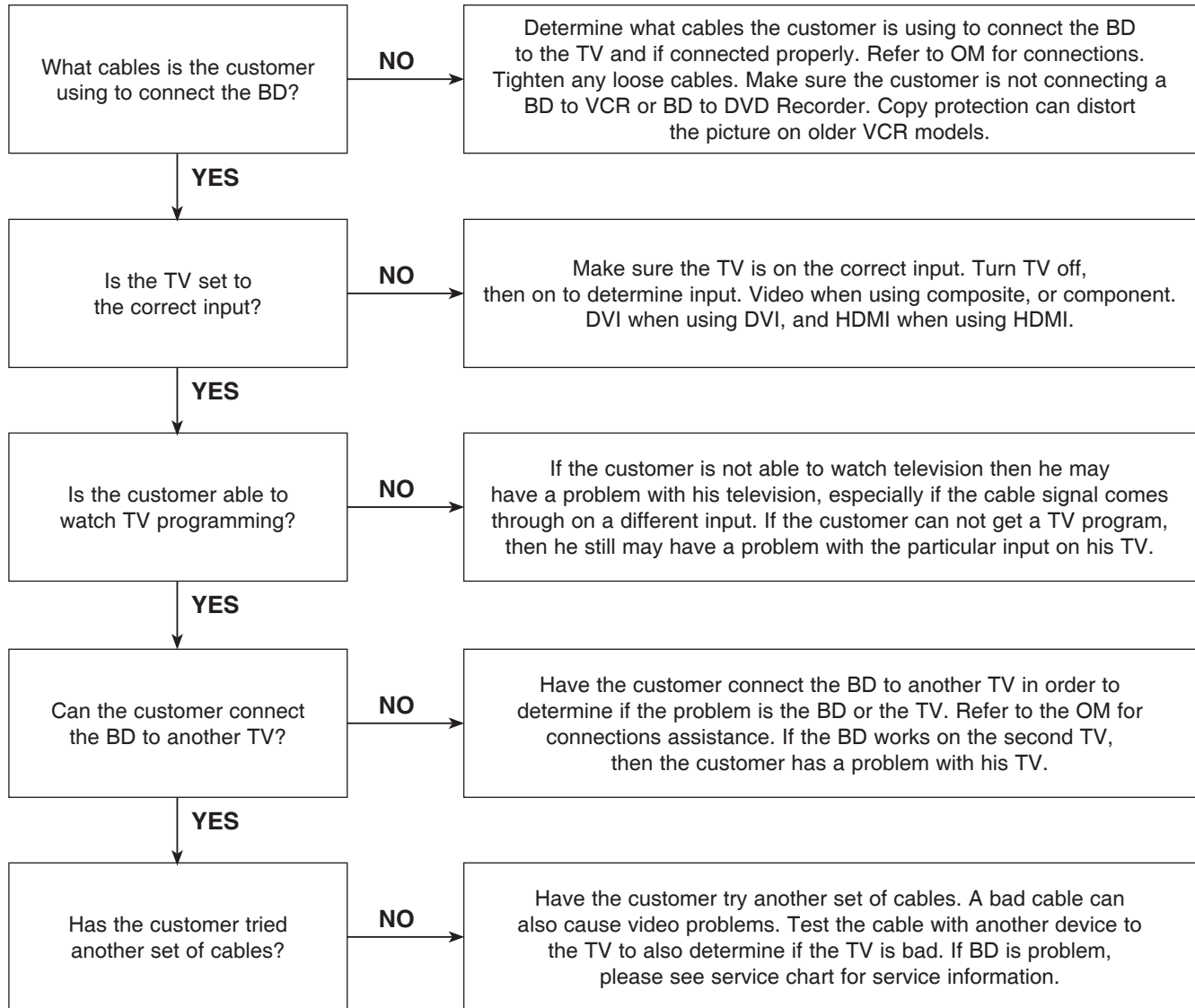



# DIGITAL DISPLAY & MEDIA TRAINING MASTER

## 2-4. No Signal

A “no signal” message appears on the screen of the display.

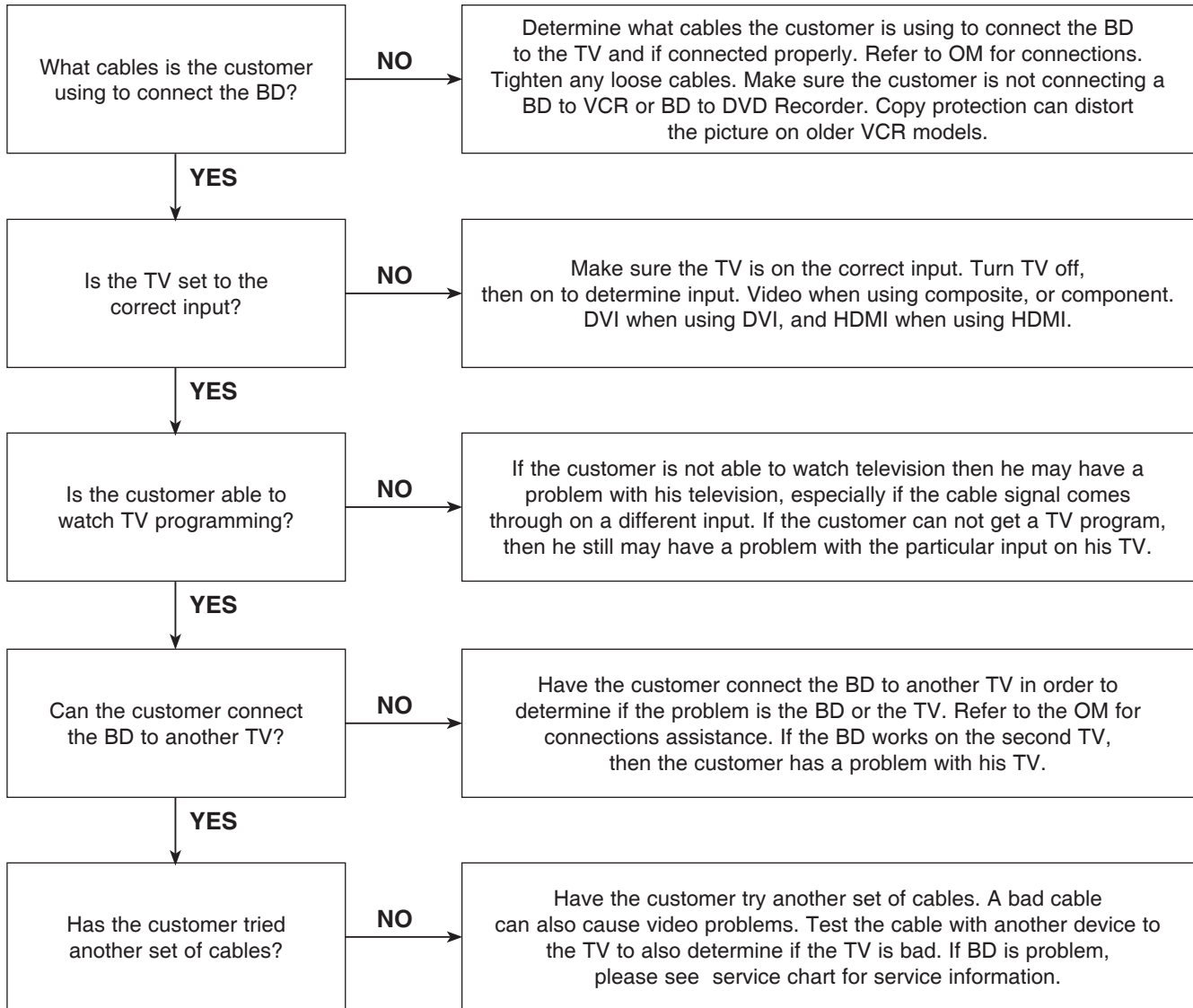

# DIGITAL DISPLAY & MEDIA TRAINING MASTER

## 2-5. Invalid Format or Format Not Supported

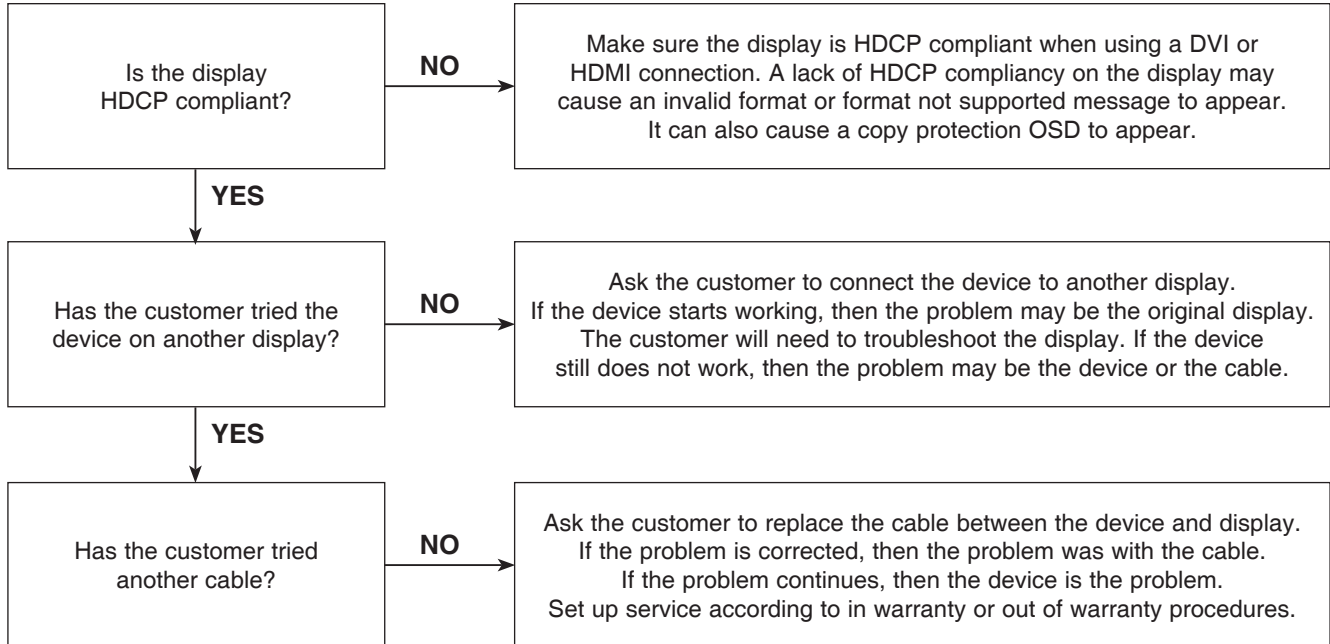

# DIGITAL DISPLAY & MEDIA TRAINING MASTER

## 3. PICTURE COLOR

### 3-1. No Color

The video displays no color and only shows in black and white.

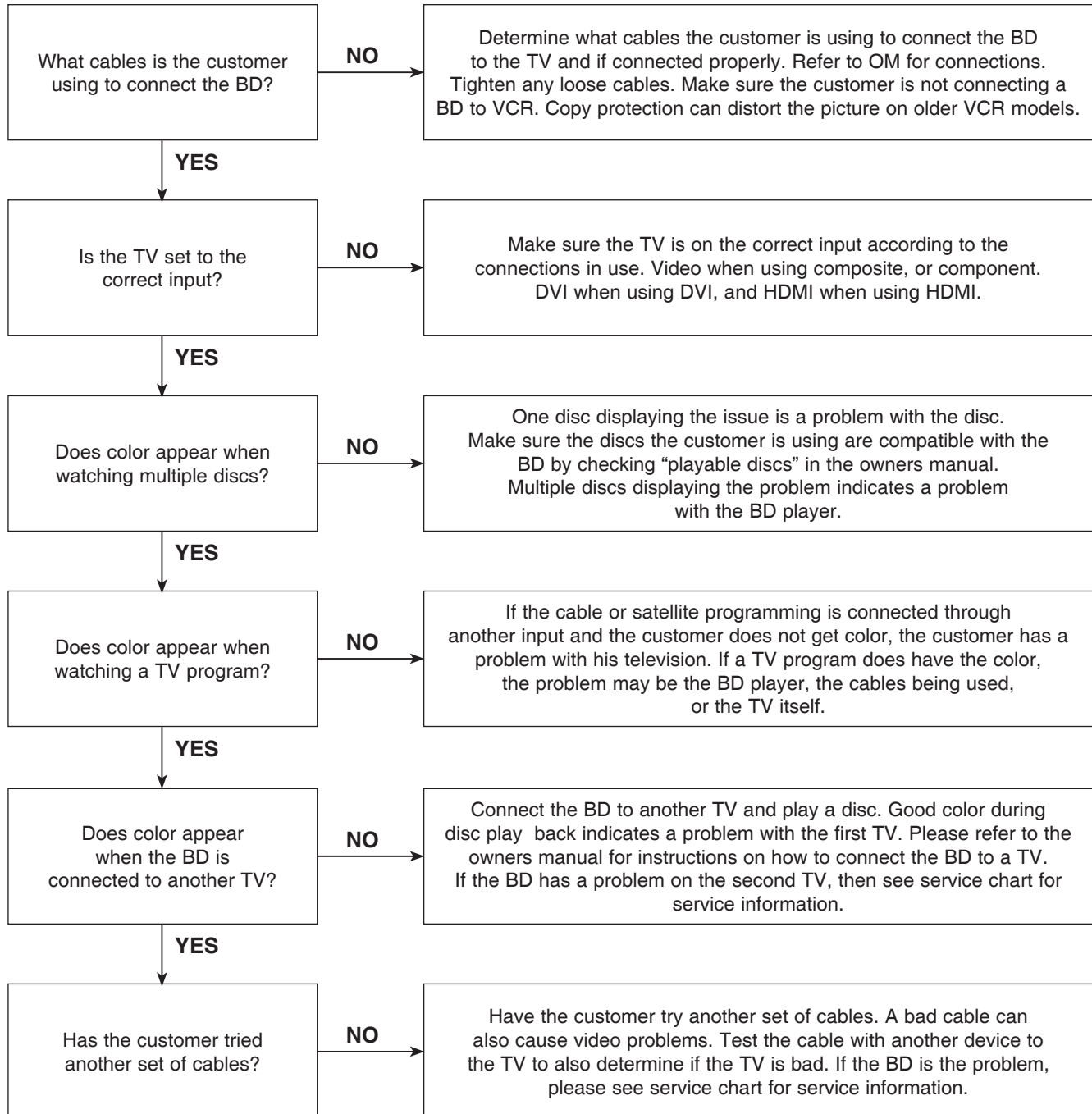

# DIGITAL DISPLAY & MEDIA TRAINING MASTER

## 3-2. Poor Color

The color is poor. Examples would be washed out colors, colors bleeding into one another, or a solid tint to a screen.

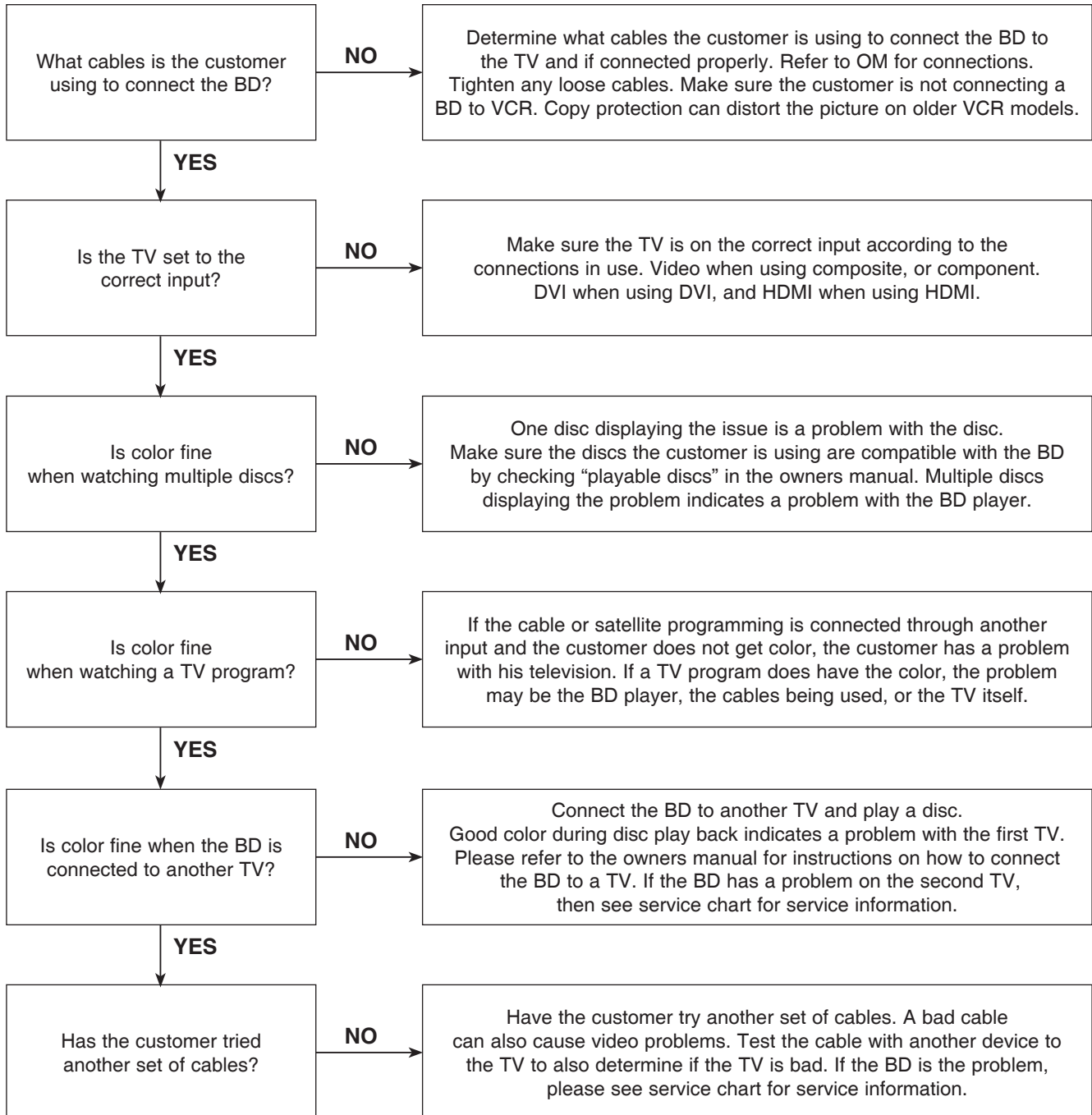

# DIGITAL DISPLAY & MEDIA TRAINING MASTER

## 4. NOISE/AUDIO PROBLEMS

### 4-1. No Audio

The customer is not able to get audio.

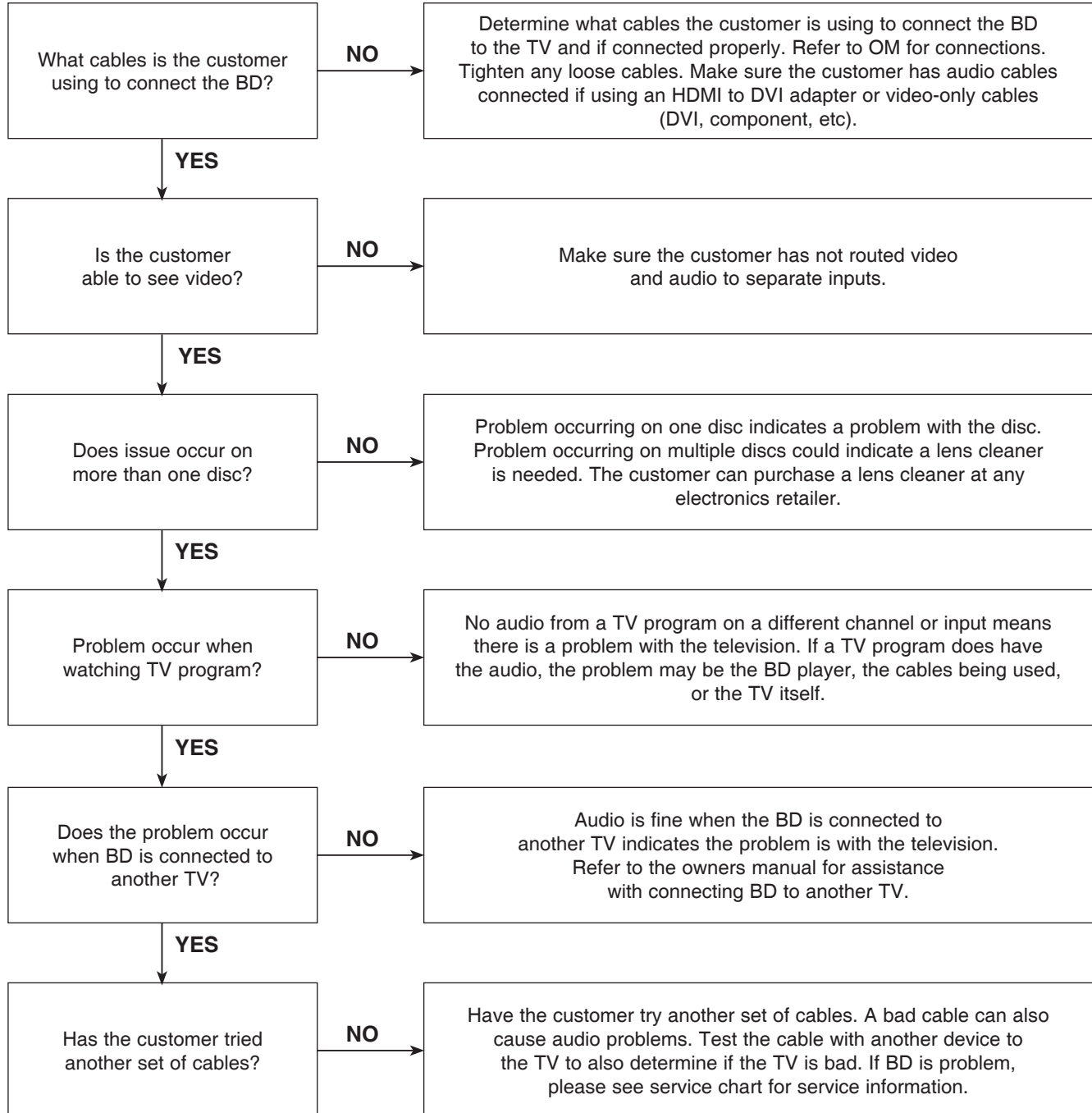

# DIGITAL DISPLAY & MEDIA TRAINING MASTER

## 4-2. Distorted Audio

The audio sounds muffled, scratchy, or the audio skips.

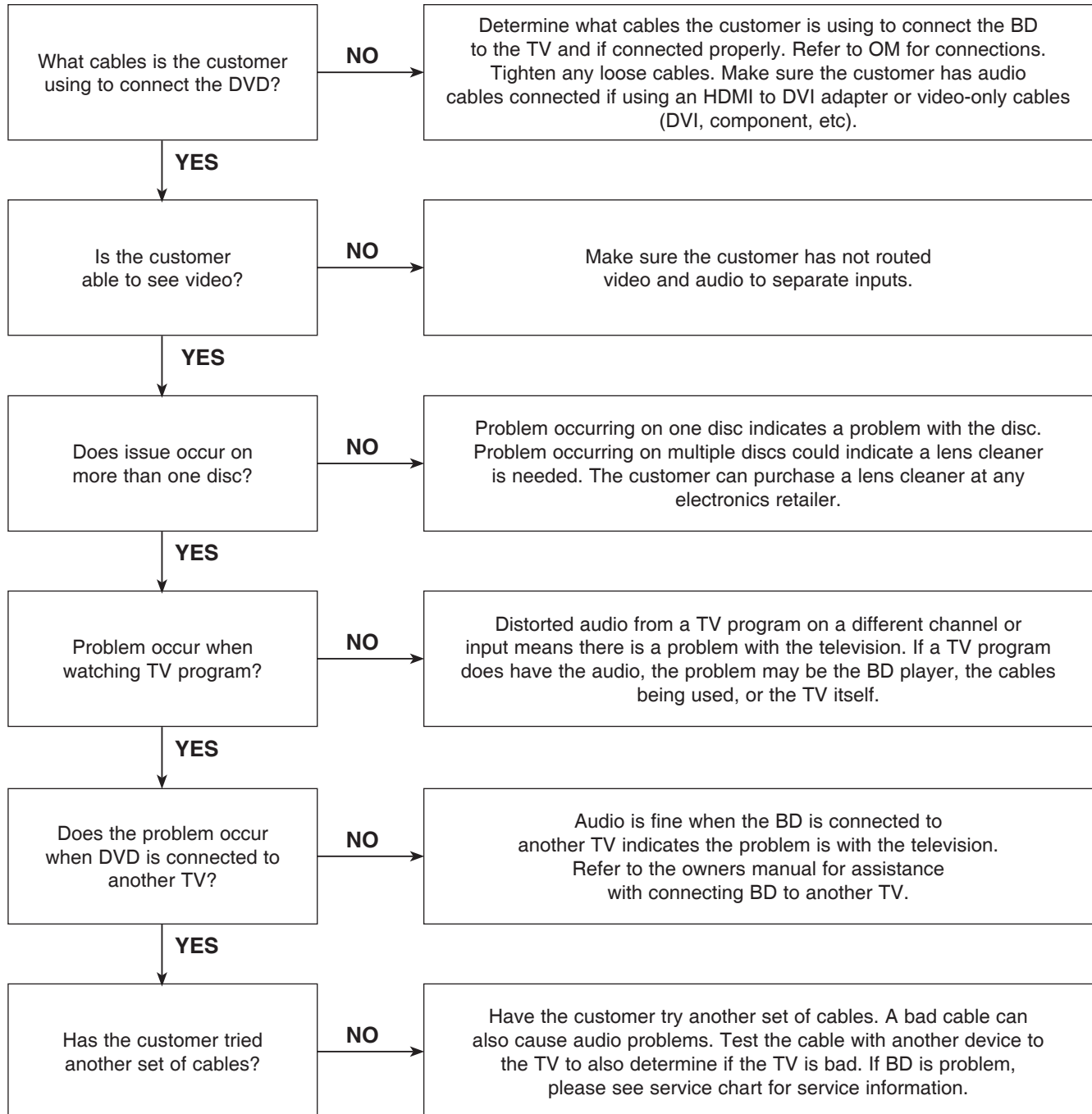

# DIGITAL DISPLAY & MEDIA TRAINING MASTER

## 4-3. Humming/Clicking Noise

The unit is making a humming noise or a clicking noise.

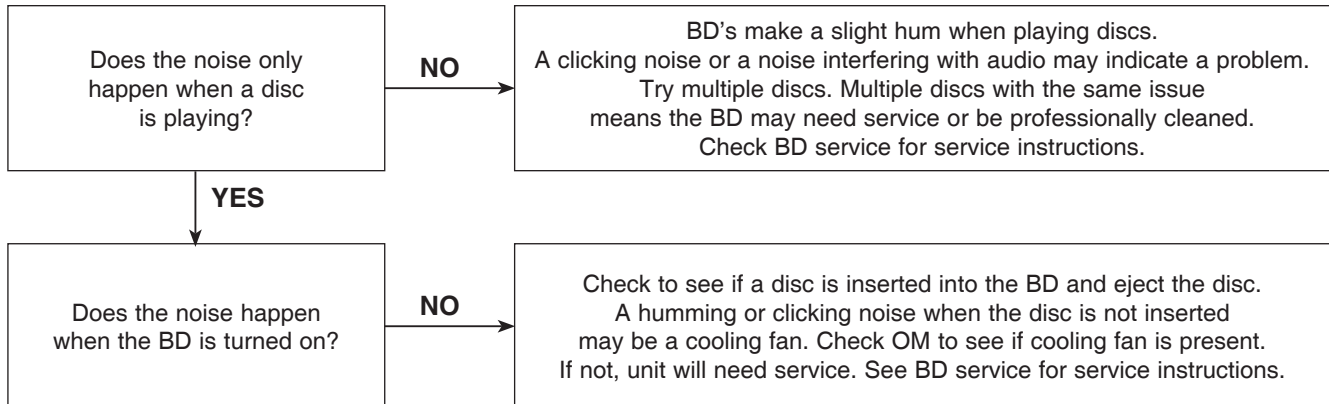

## 4-4. Audio/Video Out of Synch

The audio and video do not match up. People look to be talking, but their voices are delayed by a few seconds.

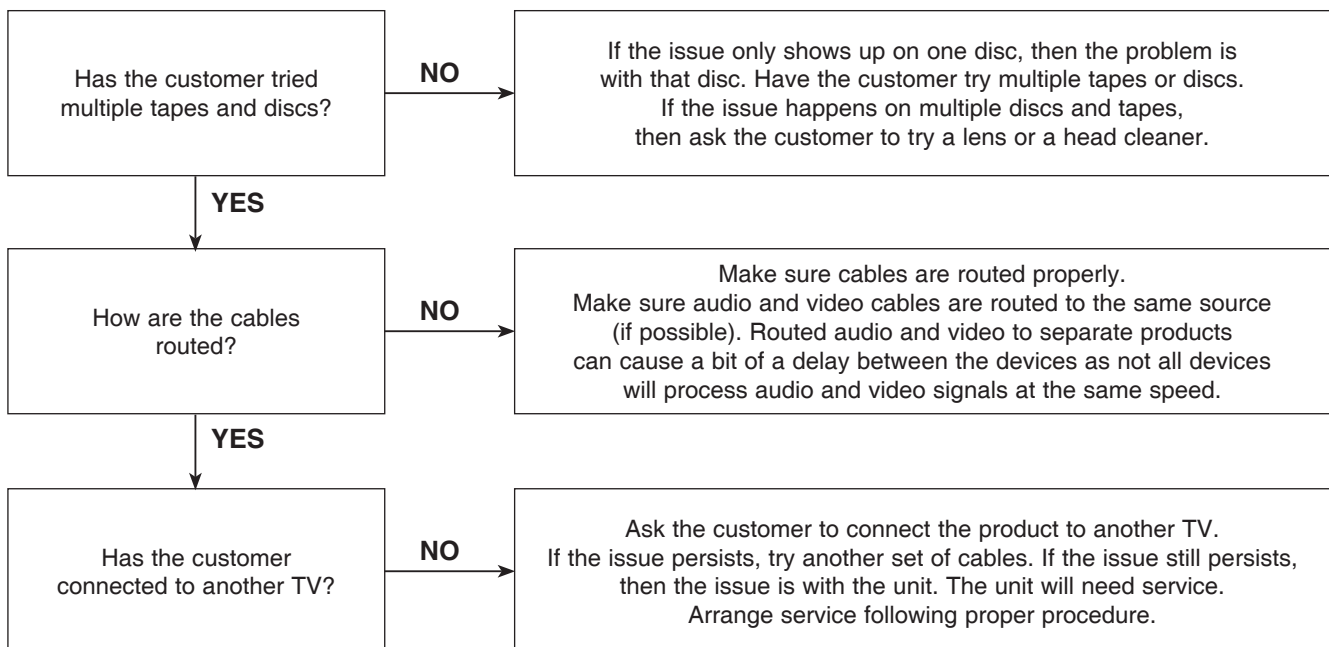

# DIGITAL DISPLAY & MEDIA TRAINING MASTER

## 5. MISCELLANEOUS

### 5-1. No Power

The unit will not turn on.

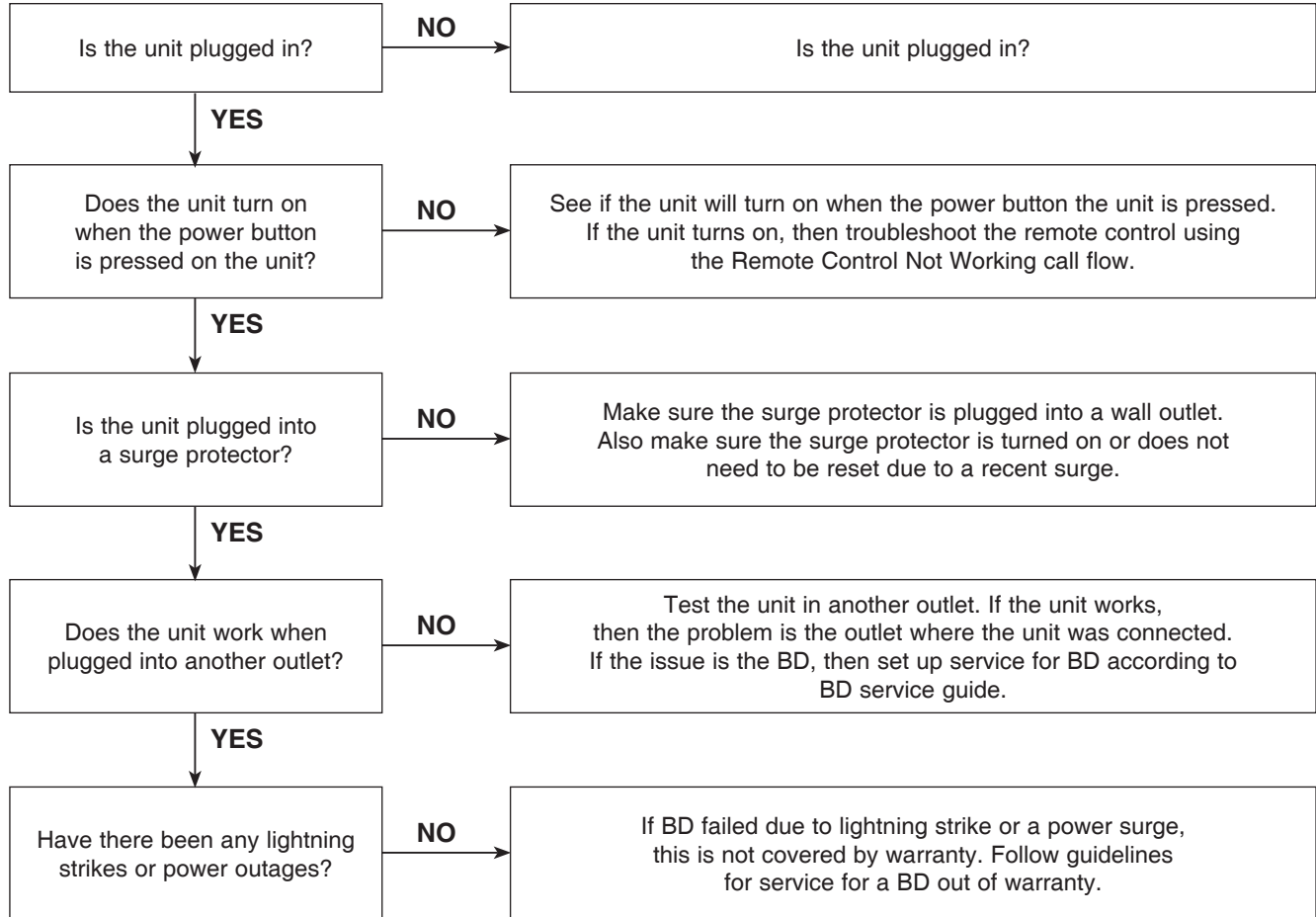



# DIGITAL DISPLAY & MEDIA TRAINING MASTER

## 5-2. Disc Error

The unit displays “disc error” when a disc is inserted into the BD player.

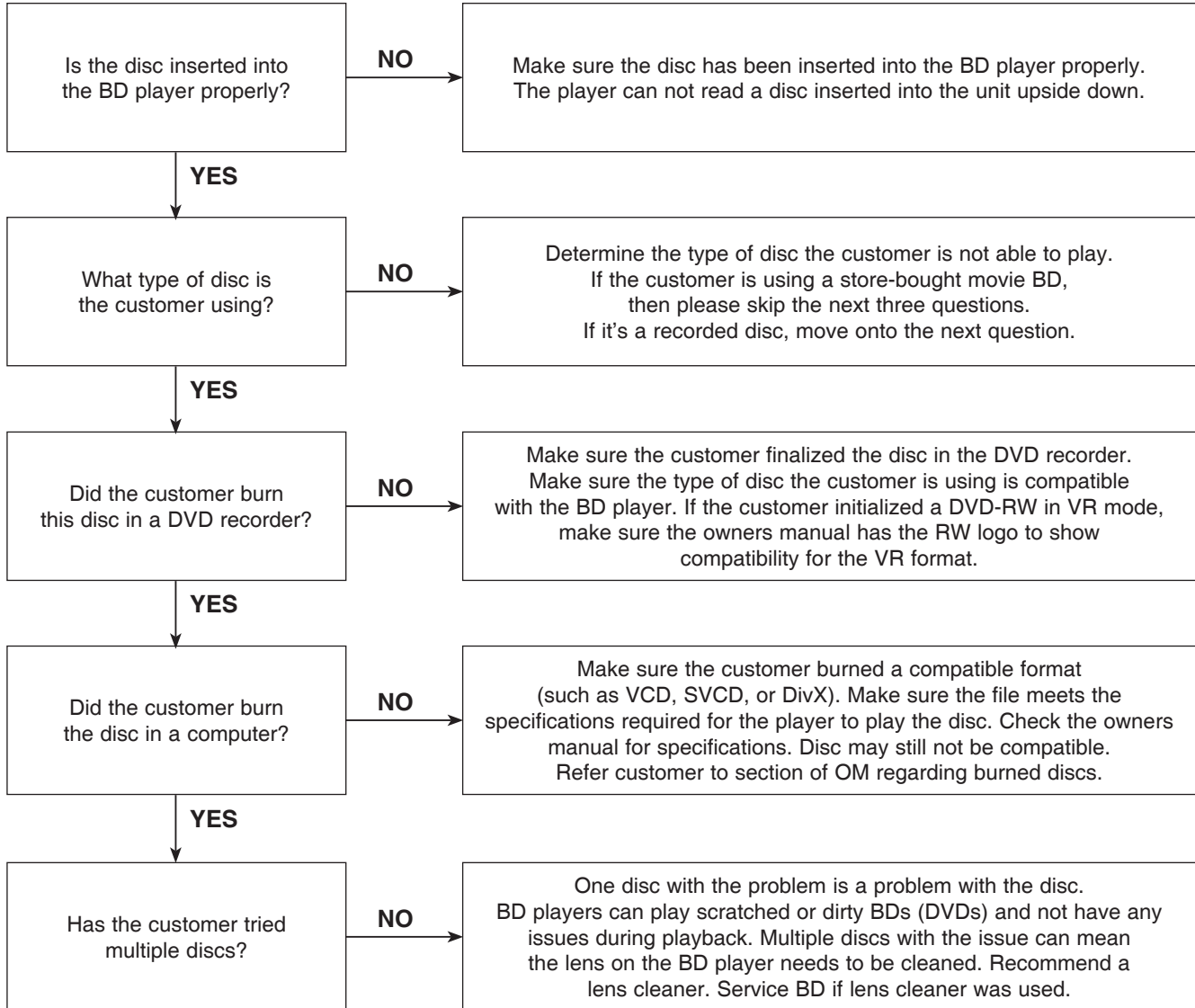

# DIGITAL DISPLAY & MEDIA TRAINING MASTER

## 5-3. Unit Locks Up

Unit does not respond to any commands.

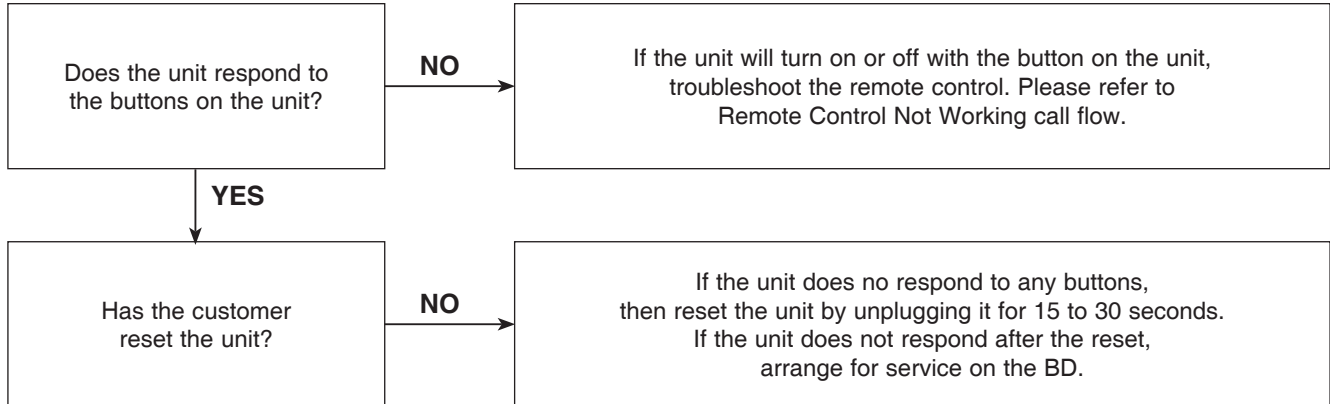

## 5-4. Disc Stuck

A BD disc is stuck in the unit.

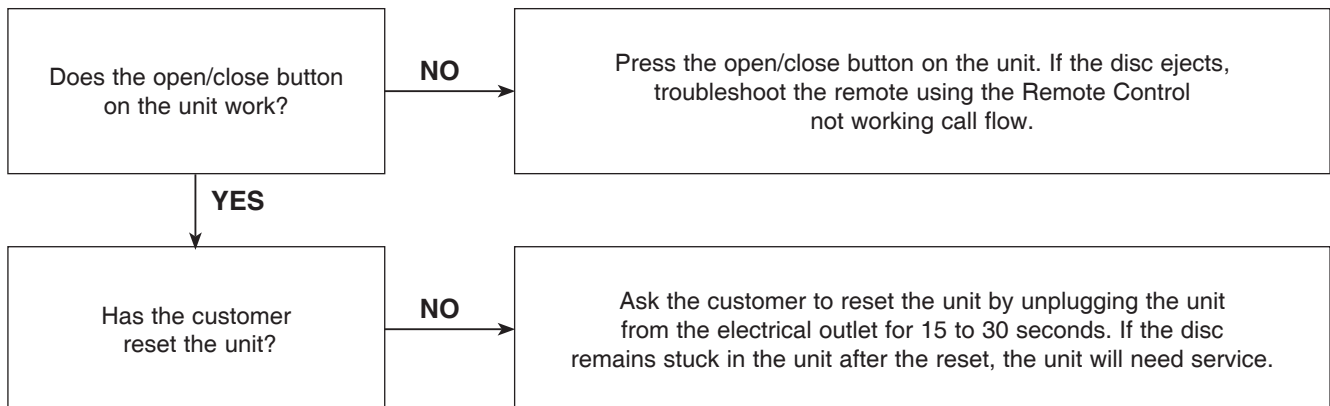

# DIGITAL DISPLAY & MEDIA TRAINING MASTER

## 5-5. Remote Control Not Working

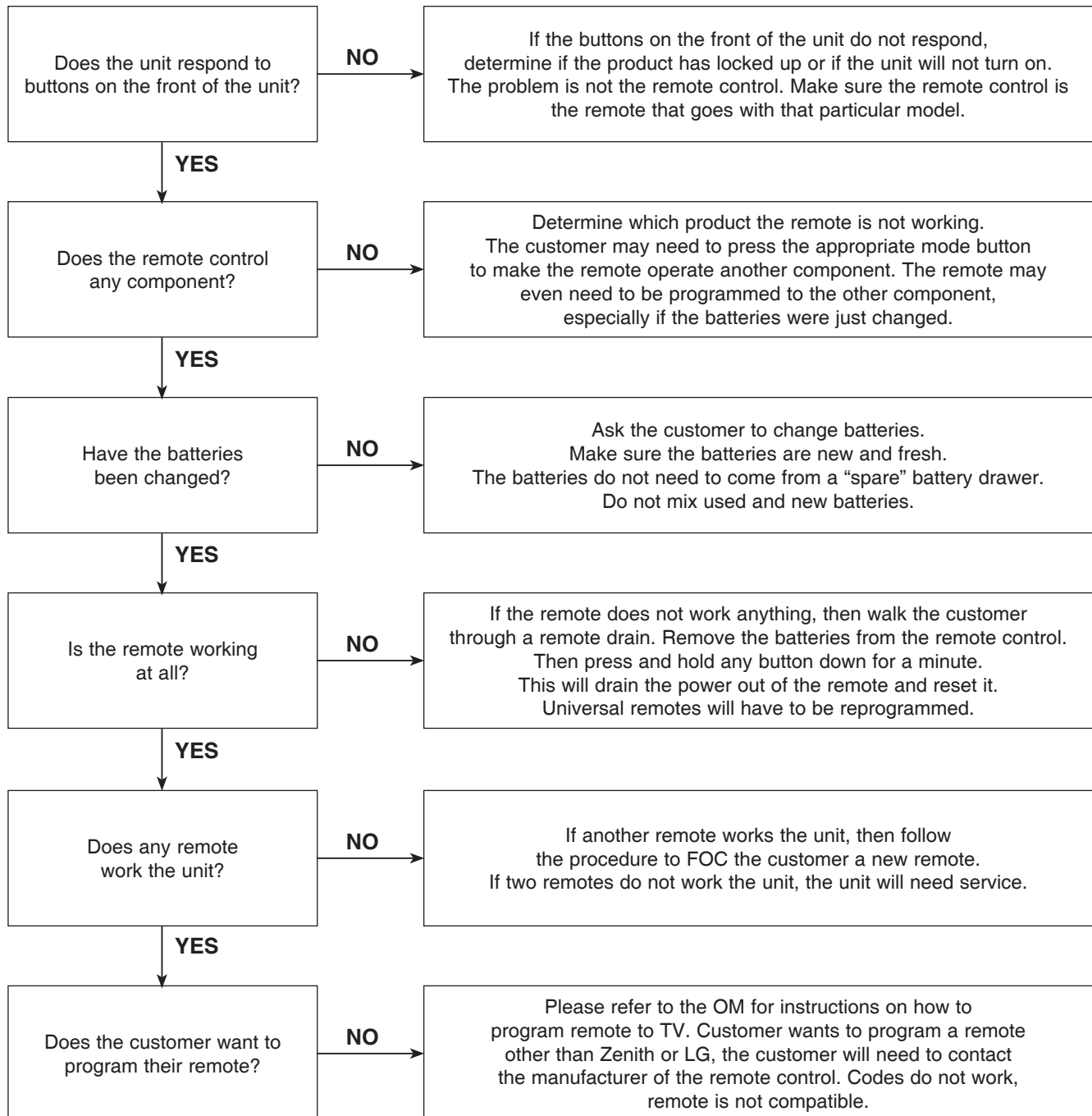

# DIGITAL DISPLAY & MEDIA TRAINING MASTER

## 5-6. Will Not Play Disc

The unit will not play a disc when a disc is inserted into the player.

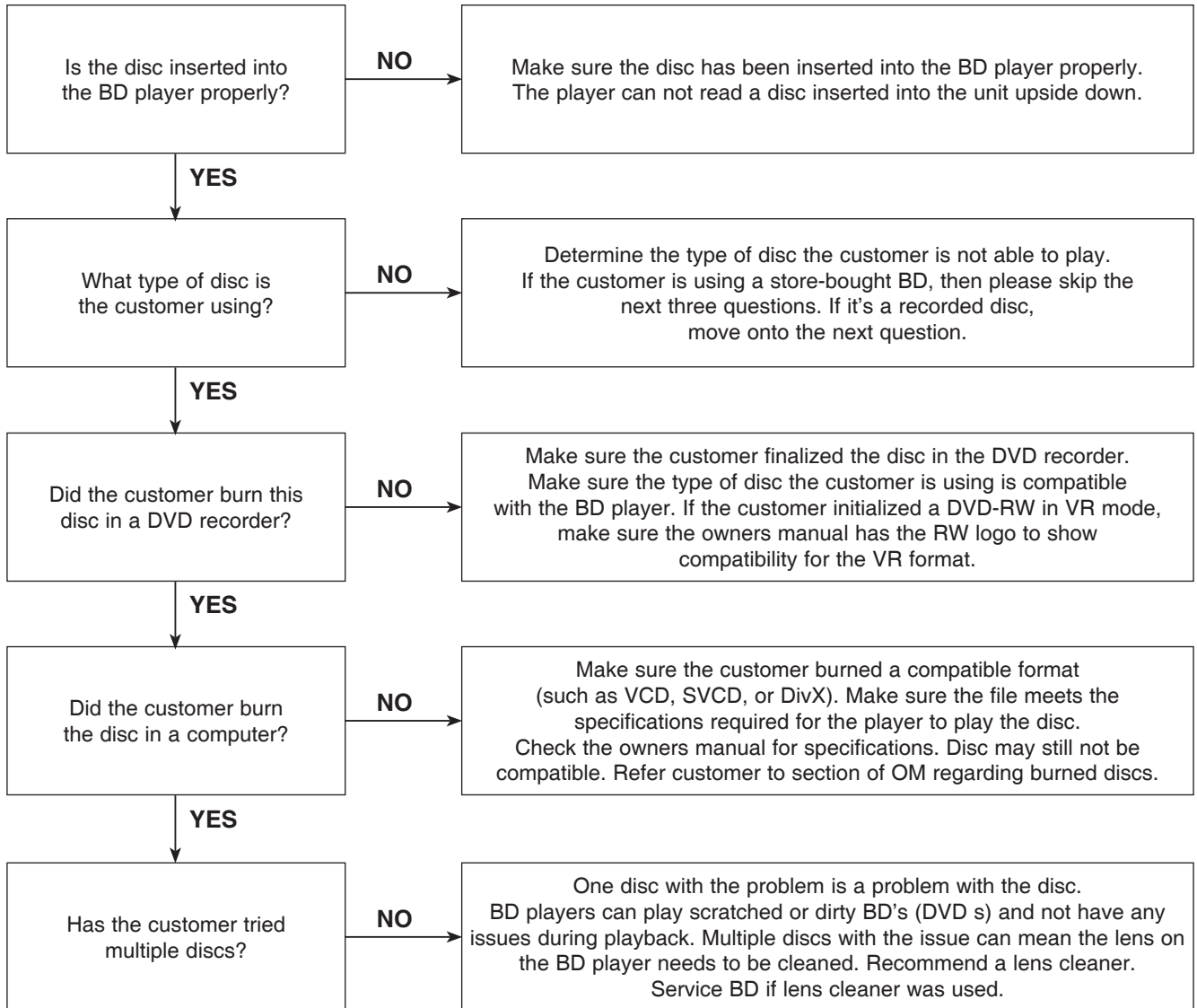

# DIGITAL DISPLAY & MEDIA TRAINING MASTER

## 5-7. Disc Freezes or Skips

The audio and video freeze and skip during play back of a BD or DVD disc.

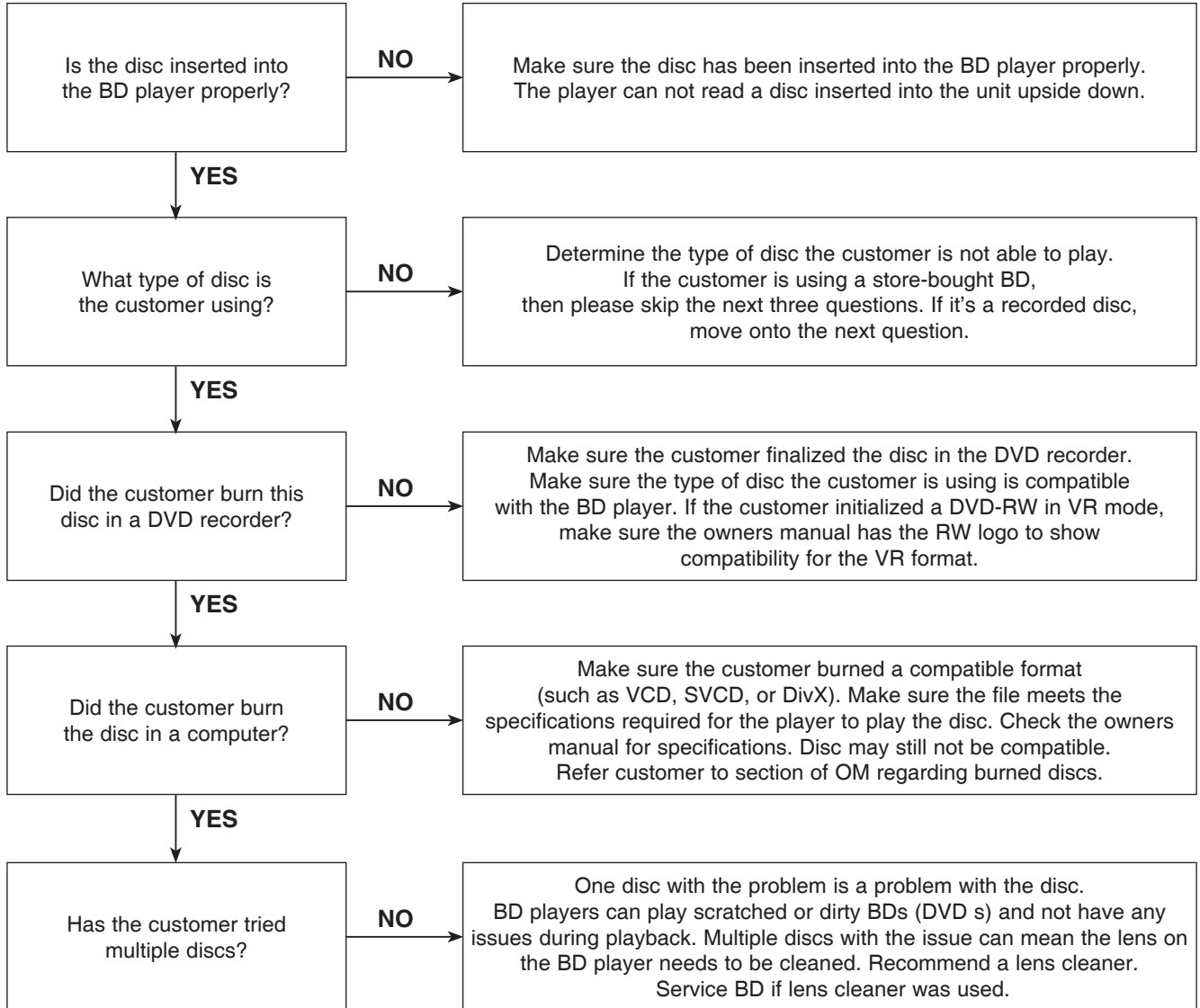

# DIGITAL DISPLAY & MEDIA TRAINING MASTER

## 5-8. Can Access Menu, but Not Play a Movie

The disc menu is displayed but the disc will not play.

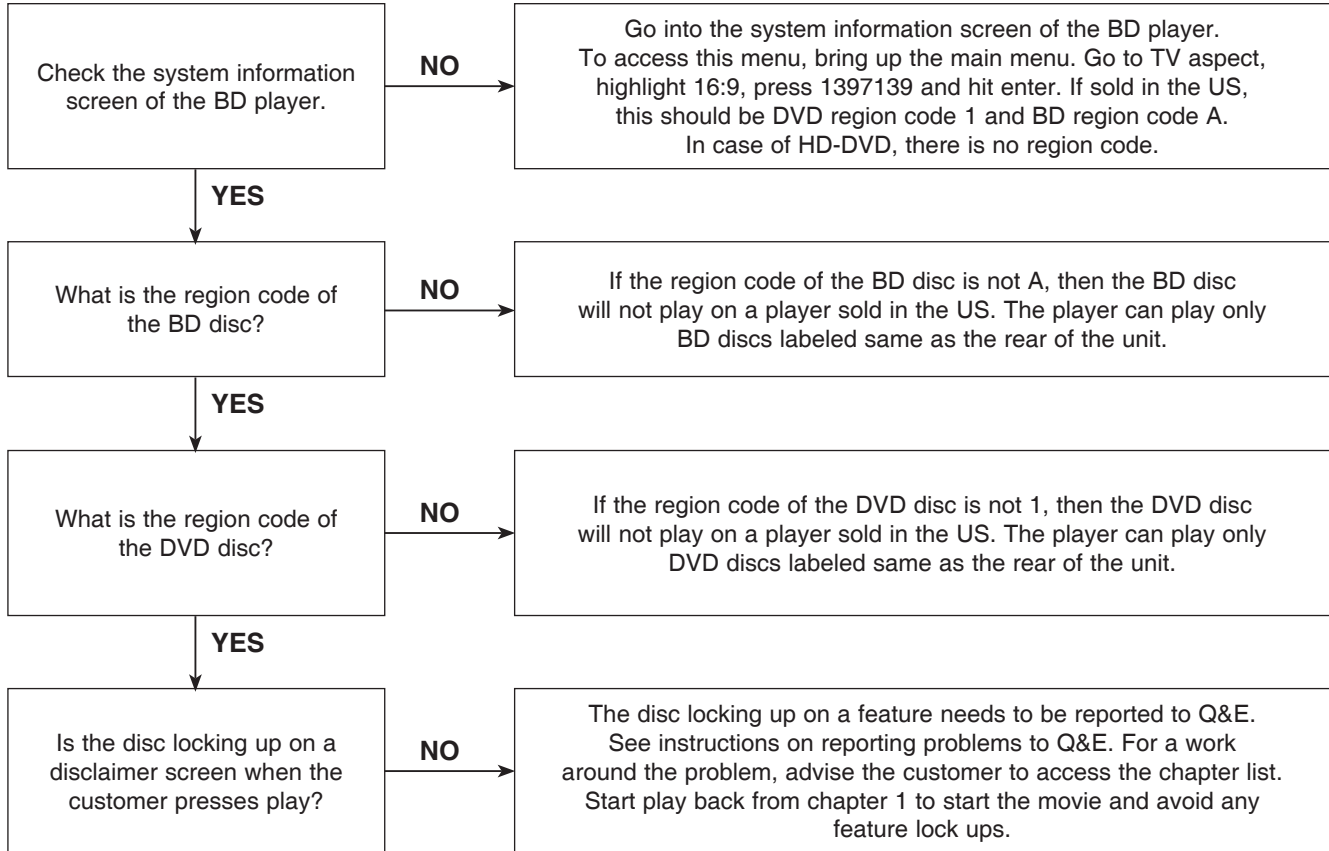

## 5-9. Reporting a problem to Quality & Engineering

Reporting a problem that may require a firmware update to fix.

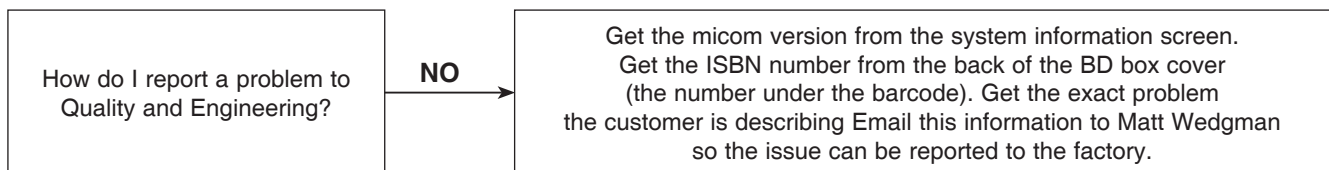

# DIGITAL DISPLAY & MEDIA TRAINING MASTER

## 5-10. Aspect Ratio

The customer has bars on the top and bottom of the screen, the left and right of the screen, or both.

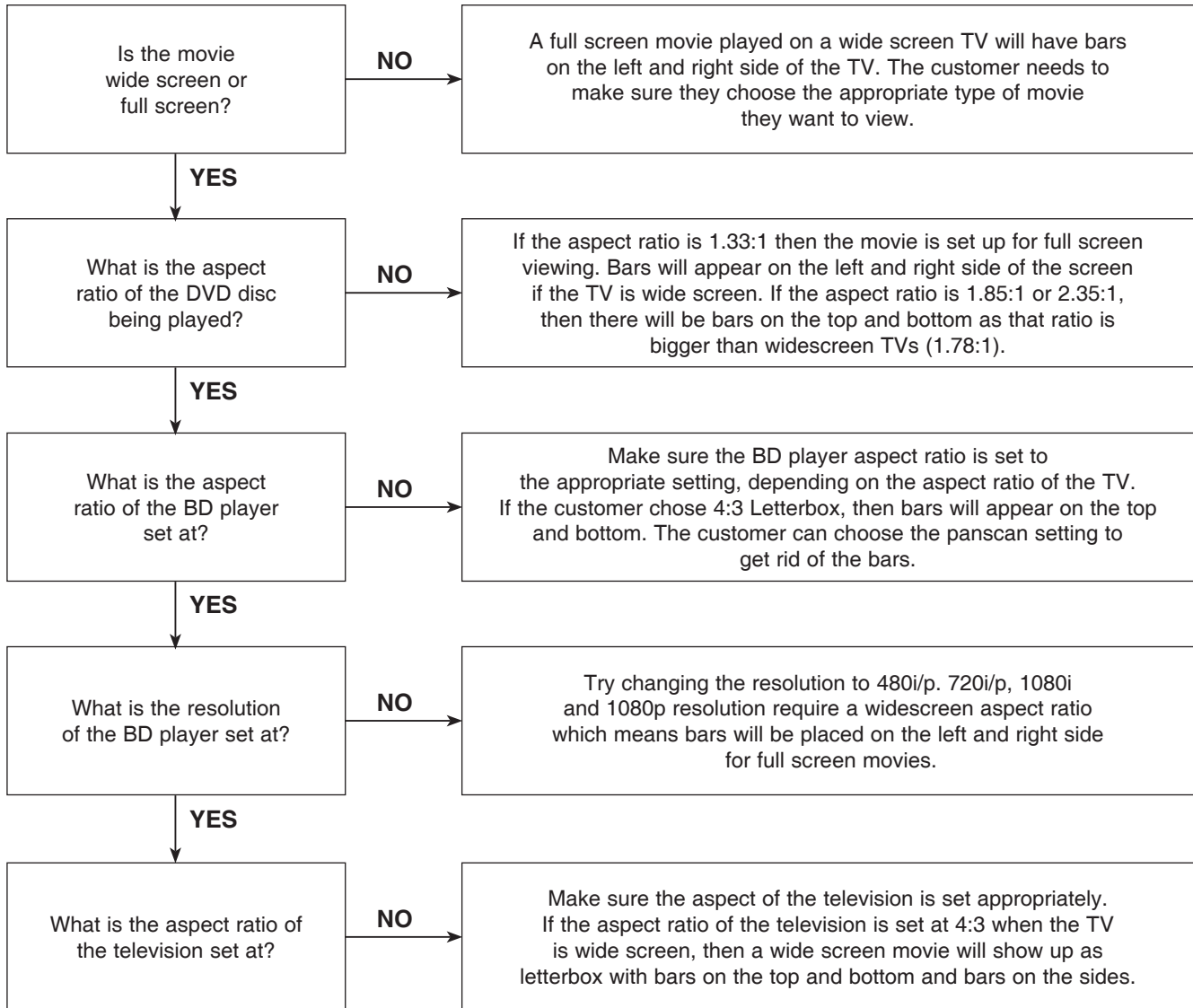

# DIGITAL DISPLAY & MEDIA TRAINING MASTER

## 5-11. My Unit Won't be up-converted

The customer has a problem with getting the unit to change resolutions to 480i/p, 720i/p, 1080i, or 1080p.

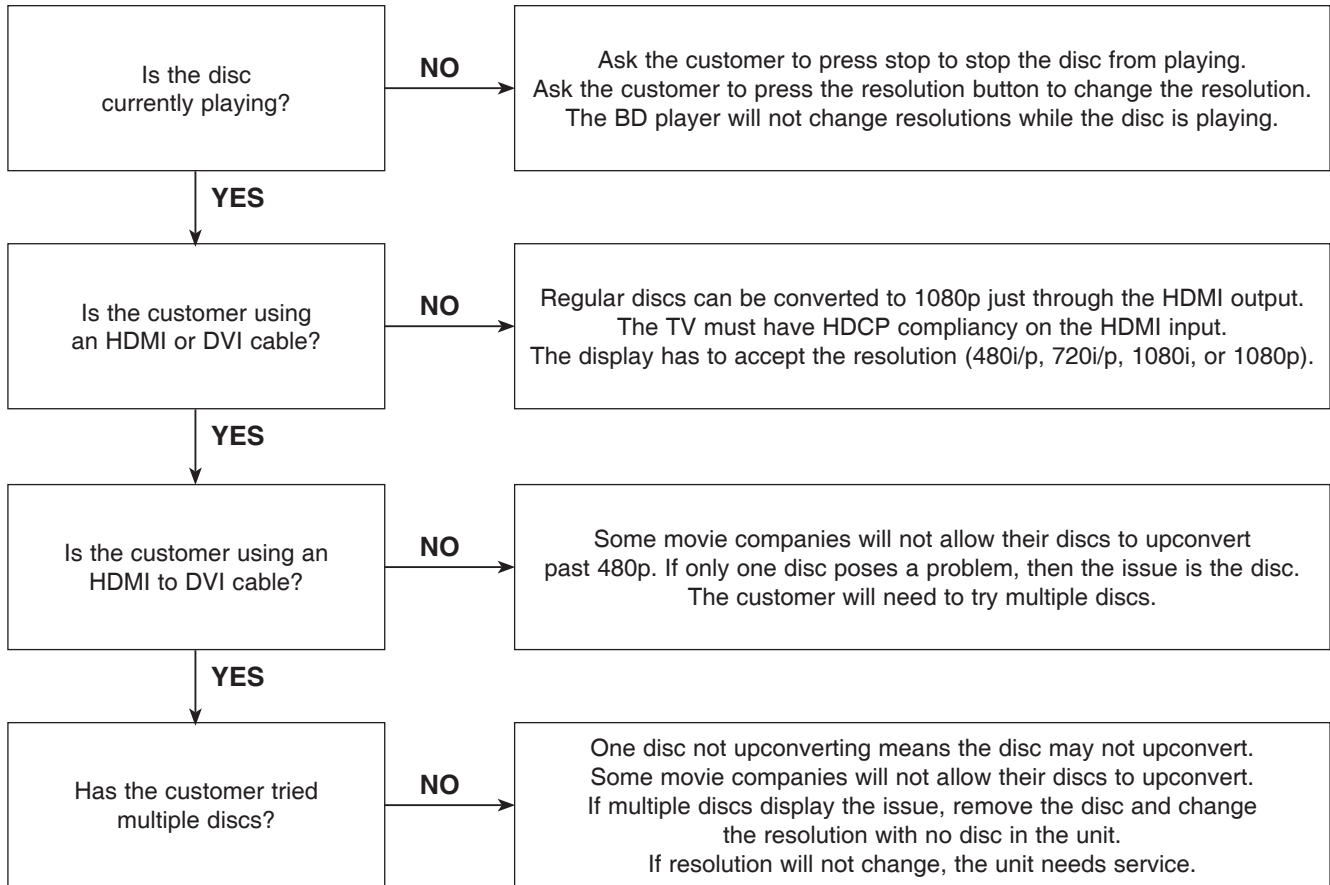



# DIGITAL DISPLAY & MEDIA TRAINING MASTER

## 6. BLU-RAY PLAYER

### 6-1. Slow Loading Times for BD's

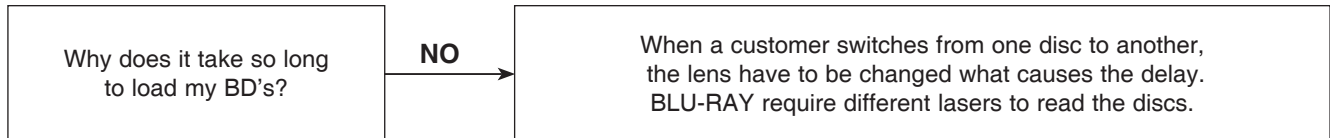

### 6-2. Booting Times

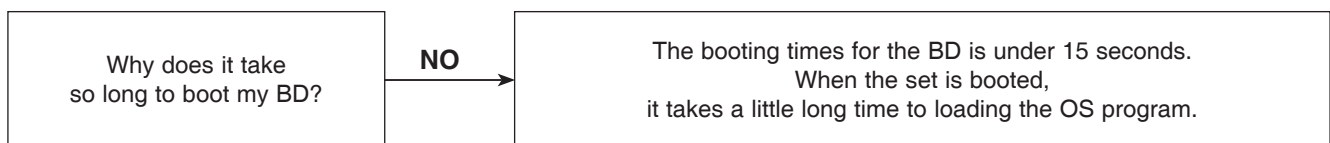

# ONE POINT REPAIR GUIDE

## 1. NO POWER PROBLEM

No power problem occurs when you power on the unit.

### 1-1. Adapter

#### 1-1-1. Solution

Replace the adapter.

#### 1-1-2. How to troubleshoot (Countermeasure)

- 1) Check the 12 VA of JK806/ L150/ L155/ C151 on main board.
- 2) If it have 12 VA, refer to the next page for checking another reason.
- 3) If it was abnormal, make sure the adapter connect to plug seat, and check the plug seat whether have power.
- 4) If plug seat have power and adapter connection is well, 12 VA still haven't, replace the adapter.

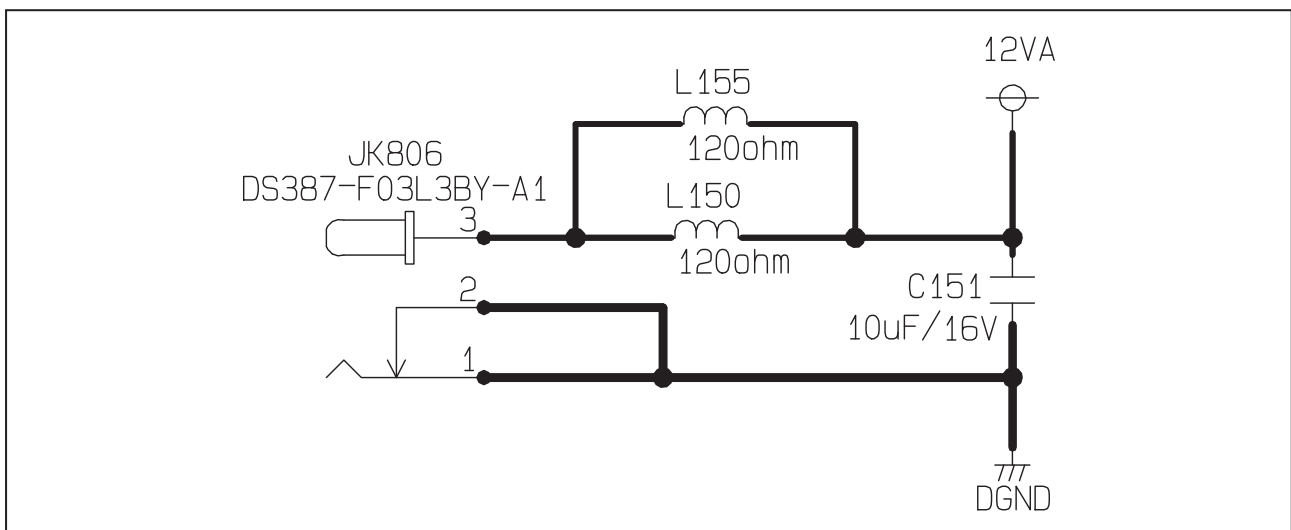

< DC-DC circuit >

#### 1-1-3. Service hint (Any picture / Remark)

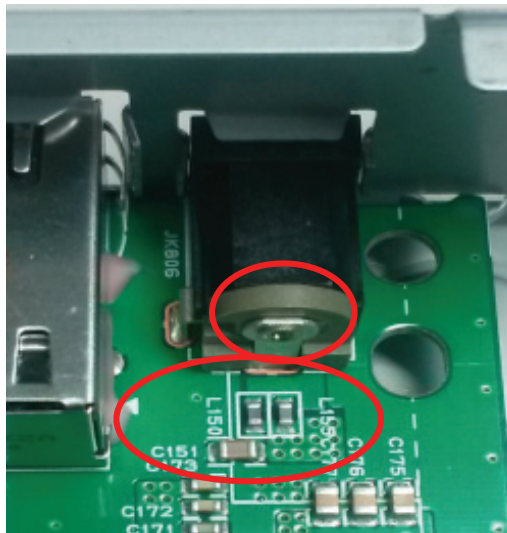

JK806, L150, L155 and C151  
< Main board top view >

# ONE POINT REPAIR GUIDE

## 2. LED DOESN'T LIGHT ON

Timer board doesn't work.

### 2-1. 5.1 VA abnormal

#### 2-1-1. Solution

Replace the IC150.

#### 2-1-2. How to troubleshoot (Countermeasure)

- 1) Check the 5.1 VA of IC150 pin9 or pin10.
- 2) If 5.1 VA doesn't come out, check the IC150 pin8 or pin13 (12 VA).  
If there is no 12 VA, check adapter (refer to 1-1-1 solution).
- 3) If 12 VA is OK, 5.1 VA is abnormal, check the PWR\_CTL is high  
and if it's high check C165, L152, C169, R169, R170, R171, C174, C175, C176, C177  
and there's no defective component, replace IC150.
- 4) If 5.1 VA is OK, but 5 V from IC150 pin 28 is abnormal, check C155, C156, R158.  
If there are high and no another defective component, replace IC150.
- 5) After changing it, if the set is still not booting:
  - Check 1.2 V/ 3.3 V/ 3.3 VA is normal. (please refer to other sections of this guide)
  - Check Crystal X501 refer to item 3-5.
  - Check NAND flash IC (IC602) refer to item 3-6.
  - Check DDR IC (IC601) refer to item 3-7.
  - Check MPEG IC (IC501) refer to item 3-8.

#### 2-1-3. Service hint (Any picture / Remark)

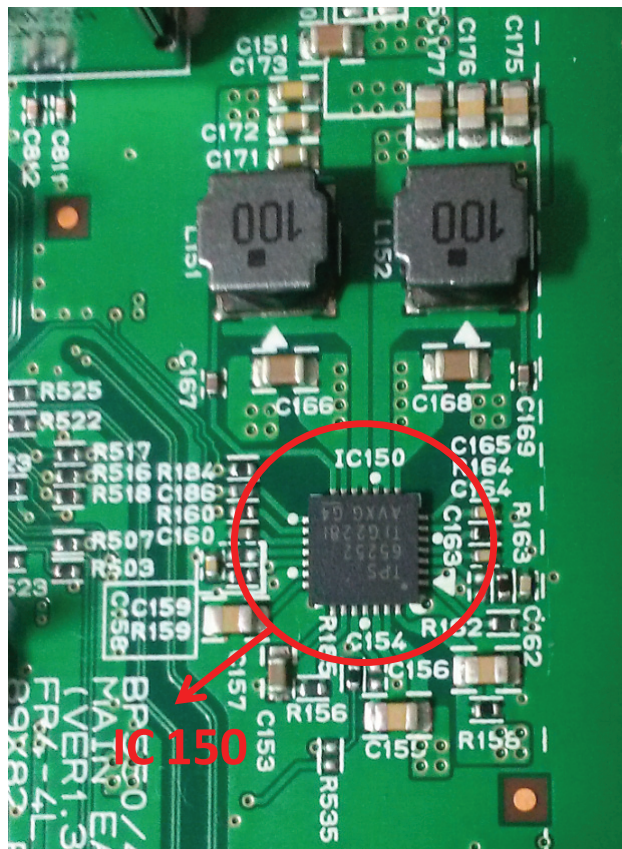

IC150  
< Main board top view >

# ONE POINT REPAIR GUIDE

## 3. NO BOOTING WHEN YOU TURN THE UNIT ON

When you turn on your set, it will blank/ no displaying Main Menu on Television/ Monitor, and it will not boot-up.

### 3-1. IC153 (No 3.3 VA)

#### 3-1-1. Solution

Replace IC153 on main board.

#### 3-1-2. How to troubleshoot (Countermeasure)

- 1) Please check 5.1 VA of IC153 pin1 (Vin).
- 2) If 5.1 VA is abnormal, refer to the solution 2-1 at the previous page.
- 3) If 5.1 VA is OK, but 3.3 VA is abnormal at the IC153 pin5 (Vout), replace IC153.

#### 3-1-3. Service hint (Any picture / Remark)

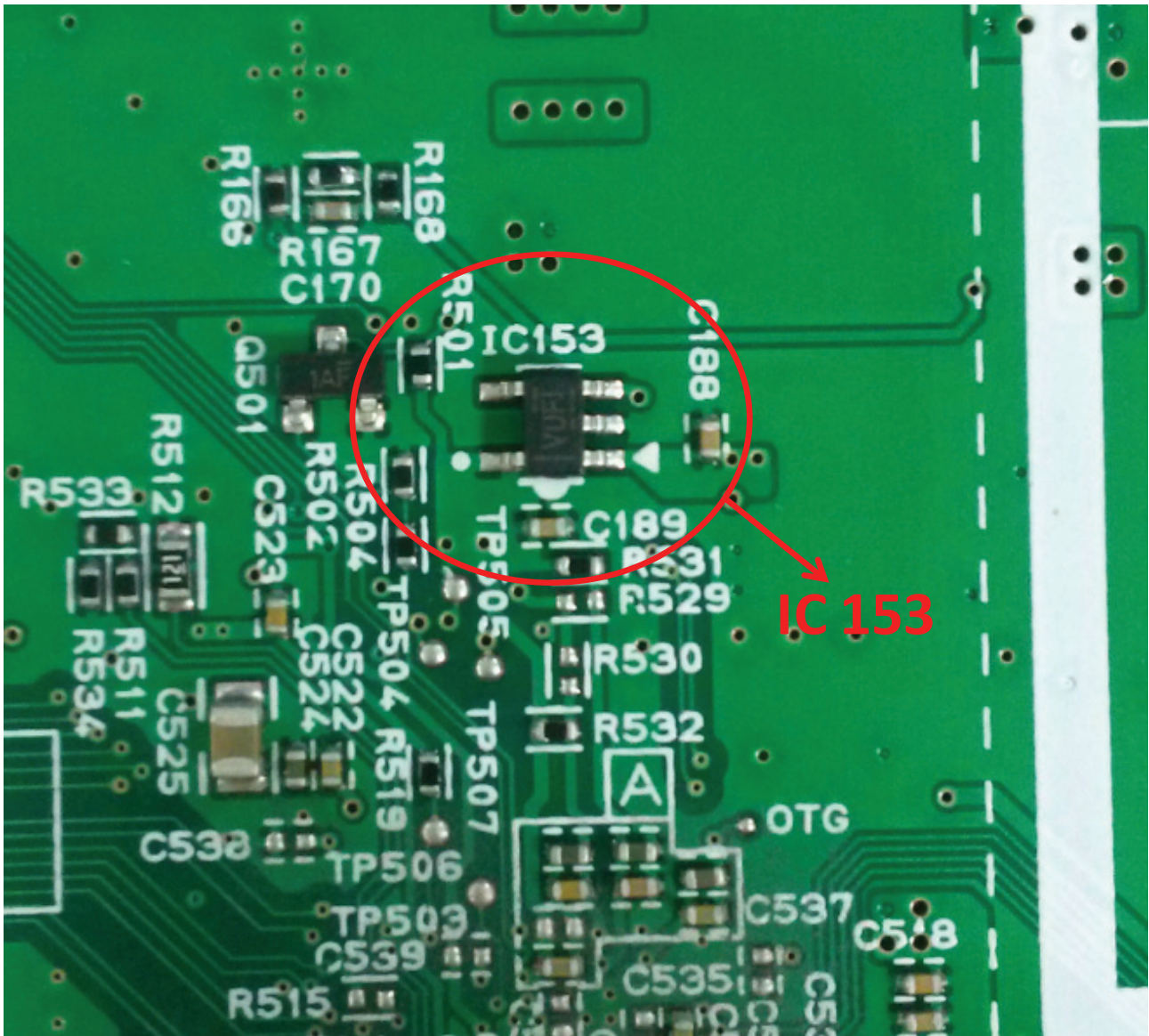

IC153  
< Main board top view >

# ONE POINT REPAIR GUIDE

## NO BOOTING WHEN YOU TURN THE UNIT ON

When you turn on your set, it will blank/ no displaying Main Menu on Television/ Monitor, and it will not boot-up.

### 3-2. IC151 (No 3.3 V)

#### 3-2-1. Solution

Replace IC151 on main board.

#### 3-2-2. How to troubleshoot (Countermeasure)

- 1) Please check 3.3 V of IC153 on main board.
- 2) If 3.3 V voltage doesn't come out, check IC151 pin2 (5.1VA).  
If there is no 5.1 VA, back to the solution 2.
- 3) If 5.1 VA input is normal, first of all check the PWR\_CTL is high (Q501 pin2).  
If PWR\_CTL is high, check R172, L153, C179, C183, R173, R174, R175, R176 and if there's no defective component then replace IC151.
- 4) After changing it, if the set is still not booting:
  - Refer to the next page for checking another power source. (1.2 V, 1.5 V)
  - Check Crystal X501 refer to item 3-5.
  - Check NAND flash IC (IC602) refer to item 3-6.
  - Check DDR IC (IC601) refer to item 3-7.
  - Check MPEG IC (IC501) refer to item 3-8.

#### 3-2-3. Service hint (Any picture / Remark)

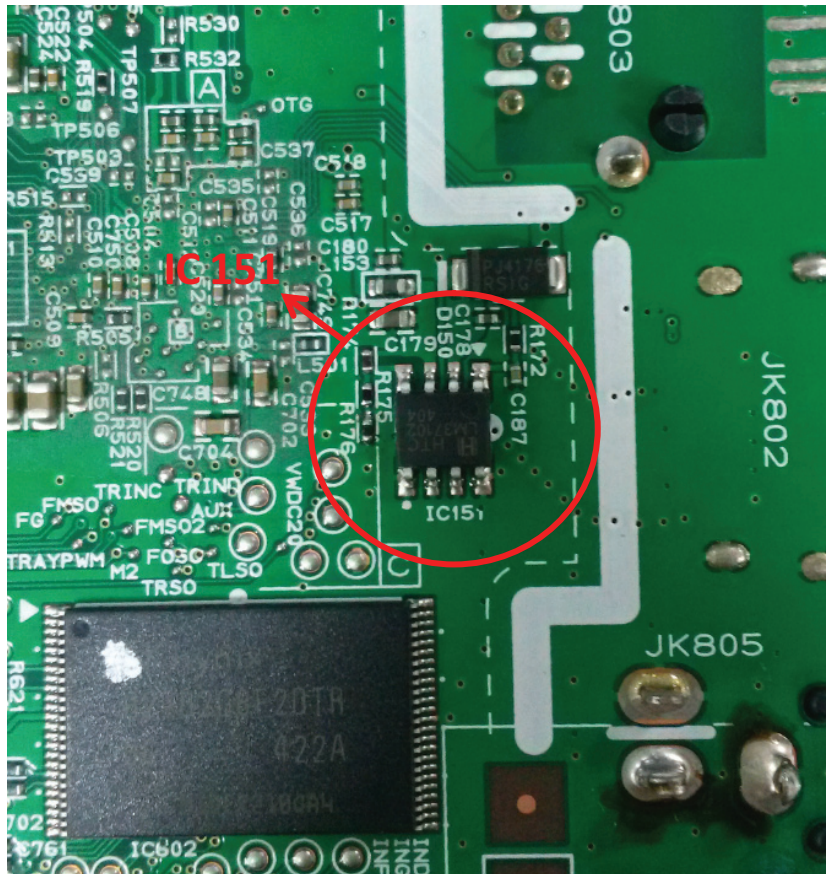

IC151

< Main board top view >

# ONE POINT REPAIR GUIDE

## NO BOOTING WHEN YOU TURN THE UNIT ON

When you turn on your set, it will blank/ no displaying Main Menu on Television/ Monitor, and it will not boot-up.

### 3-3. IC152 (No 1.5 V)

#### 3-3-1. Solution

Replace IC152 on main board.

#### 3-3-2. How to troubleshoot (Countermeasure)

- 1) Check 1.5 V of IC152 pin4.
- 2) If 1.5 V doesn't come out, check IC152 pin3 (3.3 V).  
If there is no 3.3 V, refer to previous page (solution 3-2).
- 3) If IC152 pin3 have 3.3 V, replace IC152.

#### 3-3-3. Service hint (Any picture / Remark)

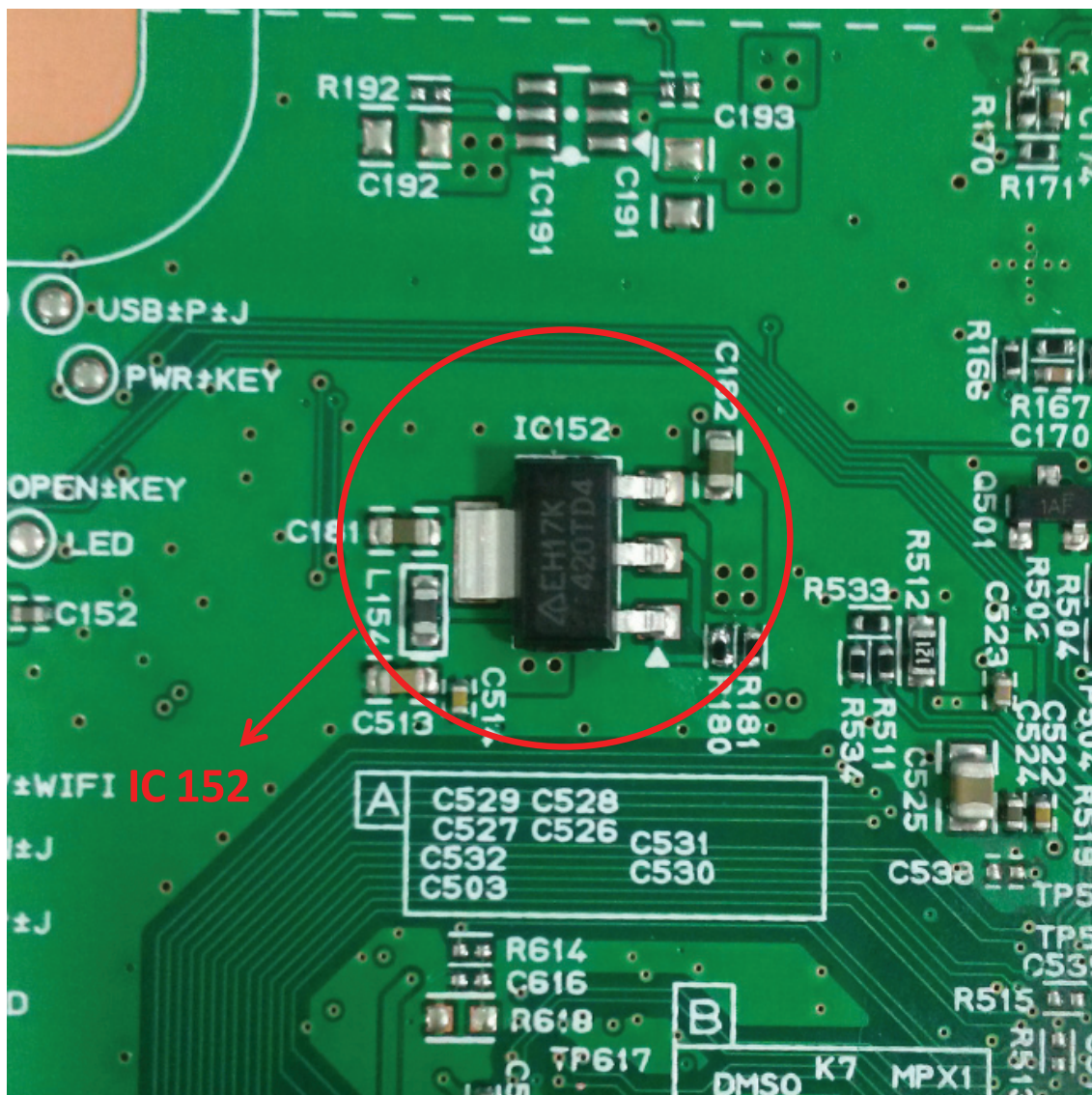

IC152  
< Main board top view >

# ONE POINT REPAIR GUIDE

## NO BOOTING WHEN YOU TURN THE UNIT ON

When you turn on your set, it will blank/ no displaying Main Menu on Television/ Monitor, and it will not boot-up.

### 3-4. IC150 (No 1.2 V)

#### 3-4-1. Solution

Replace IC150 on main board.

#### 3-4-2. How to troubleshoot (Countermeasure)

- 1) Please check 1.2 V of IC150 pin11/ pin12.
- 2) If 1.2 V voltage doesn't come out, check IC150 pin13 (12 VA).  
If there is no 12 VA, go to previous solution to check it.
- 3) If 12 VA is OK, check the PWR\_CTL is high  
and if it's high check C167, L151, R166, R167, R168, C170, C171, C172, C173  
and if there's no defective component, please replace IC150.
- 4) After changing it, if the set is still not booting:
  - Check 1.2 V/ 3.3 V/ 3.3 VA is normal. (please refer to other sections of this guide)
  - Check Crystal X501 refer to item 3-5.
  - Check NAND flash IC (IC602) refer to item 3-6.
  - Check DDR IC (IC601) refer to item 3-7.
  - Check MPEG IC (IC501) refer to item 3-8.

#### 3-4-3. Service hint (Any picture / Remark)

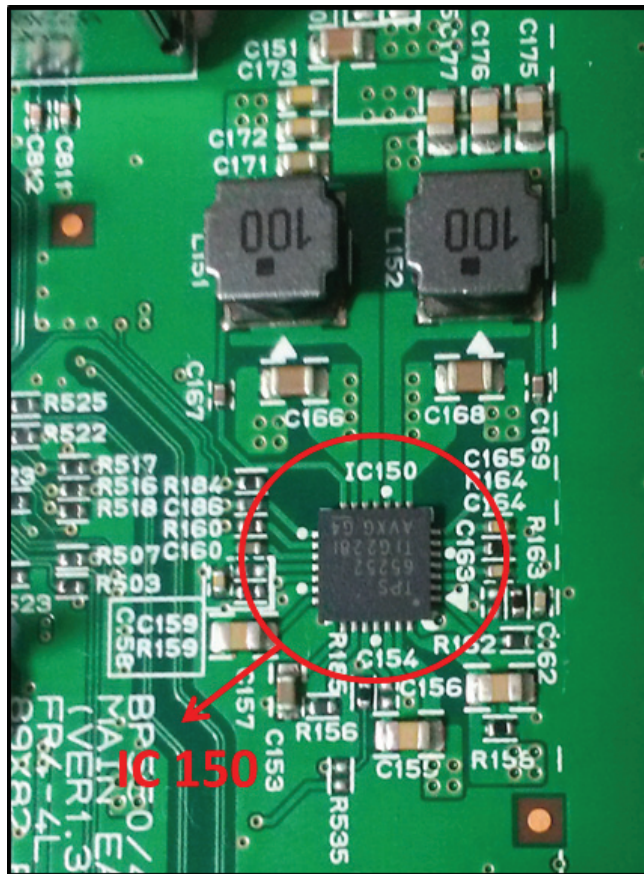

IC150  
< Main board top view >

# ONE POINT REPAIR GUIDE

## NO BOOTING WHEN YOU TURN THE UNIT ON

When you turn on your set, it will blank/ no displaying Main Menu on Television/ Monitor, and it will not boot-up.

### 3-5. X501

#### 3-5-1. Solution

Replace X501 on main board.

#### 3-5-2. How to troubleshoot (Countermeasure)

- 1) Please check the soldering status of 27 MHz crystal (X501).
- 2) Please check the frequency of 27 MHz crystal (X501).
- 3) If the crystal doesn't oscillate, replace X501.
- 4) After changing it, if the set is still not booting:
  - Check NAND flash IC (IC602) refer to item 3-6.
  - Check DDR IC (IC601) refer to item 3-7.
  - Check MPEG IC (IC501) refer to item 3-8.

#### 3-5-3. Service hint (Any picture / Remark)

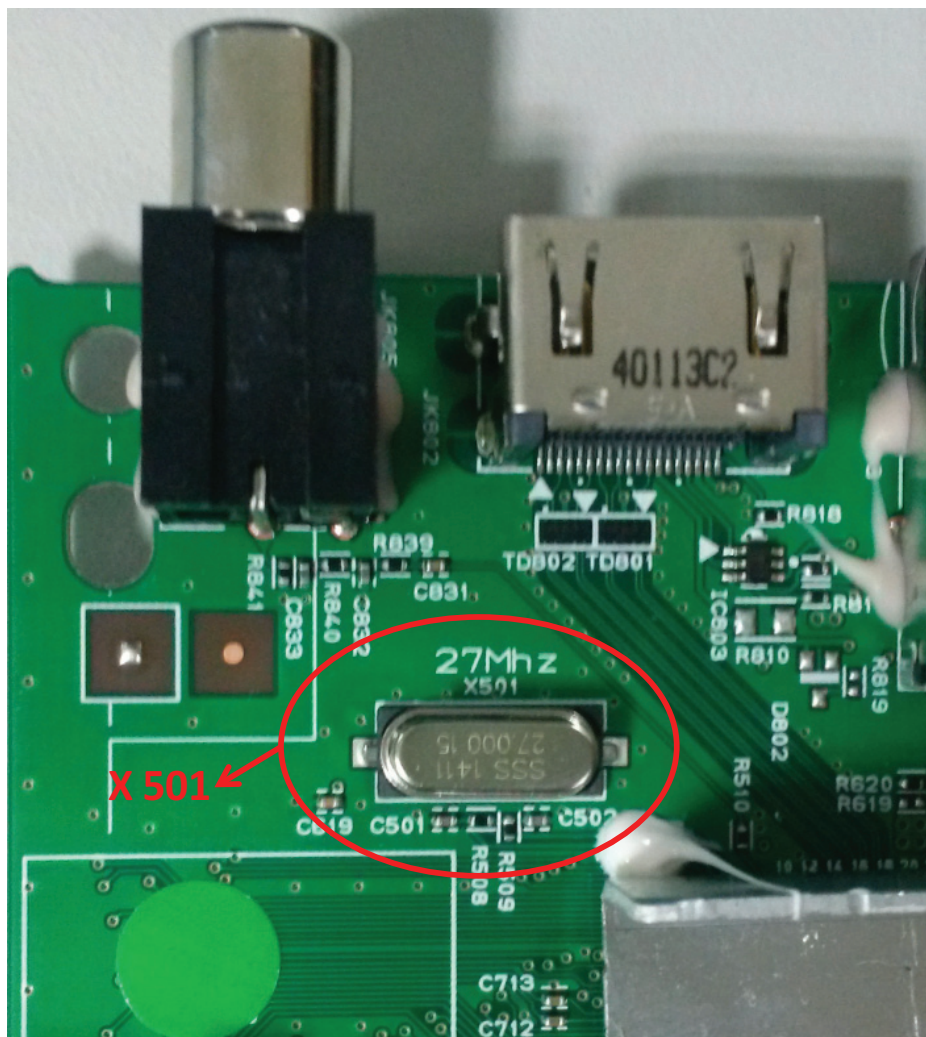

X501  
< Main board top view >



# ONE POINT REPAIR GUIDE

## NO BOOTING WHEN YOU TURN THE UNIT ON

When you turn on your set, it will blank/ no displaying Main Menu on Television/ Monitor, and it will not boot-up.

### 3-6. IC602 (NAND FLASH MEMORY)

#### 3-6-1. Solution

Replace IC602 on main board.

#### 3-6-2. How to troubleshoot (Countermeasure)

- 1) Please check physical status of IC602 on your eyes.
- 2) Check the Vcc (3.3 V) of IC602  
and if it's normal please replace IC602. (Please make sure IC602 has proper program.)
- 3) After changing it, if the set is still not booting:
  - Check DDR IC (IC601) refer to item 3-7.
  - Check MPEG IC (IC501) refer to item 3-8.

#### 3-6-3. Service hint (Any picture / Remark)

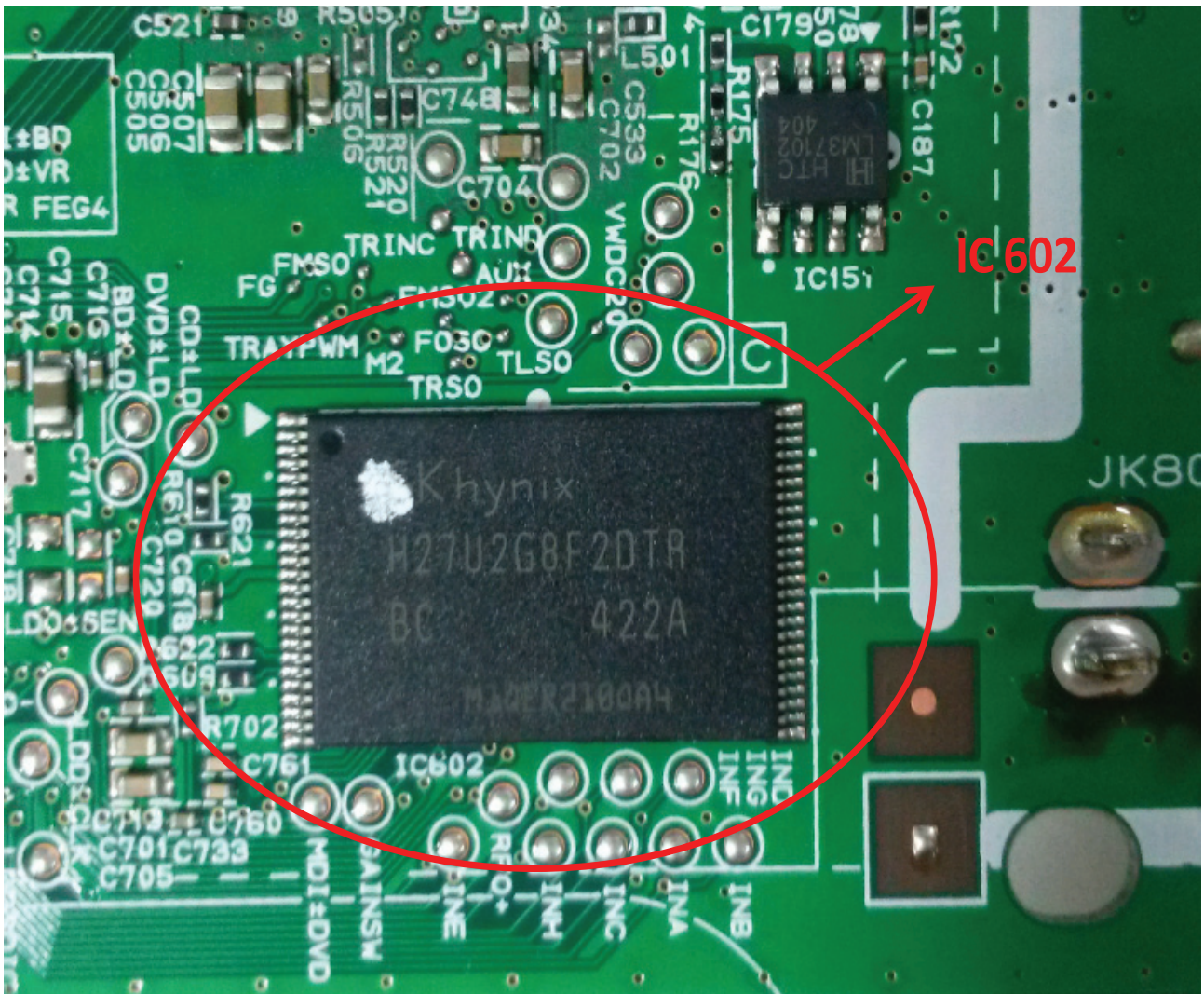

# ONE POINT REPAIR GUIDE

## NO BOOTING WHEN YOU TURN THE UNIT ON

When you turn on your set, it will blank/ no displaying Main Menu on Television/ Monitor, and it will not boot-up.

### 3-7. IC601 (DDR3 MEMORY)

#### 3-7-1. Solution

Replace IC601 on main board.

#### 3-7-2. How to troubleshoot (Countermeasure)

- 1) Please check 0.75 V of DDR3\_VREF (C606, R607).  
Please check 1.5 V of C613.
- 2) If it doesn't work even though IC150, IC151, IC152, IC153 are no problem, IC601 (DDR memory) could have problem.
- 3) After changing it, if the set is still not booting:
  - Check MPEG IC (IC501) refer to item 3-8.
  - Check main board refer to item 3-9.

#### 3-7-3. Service hint (Any picture / Remark)

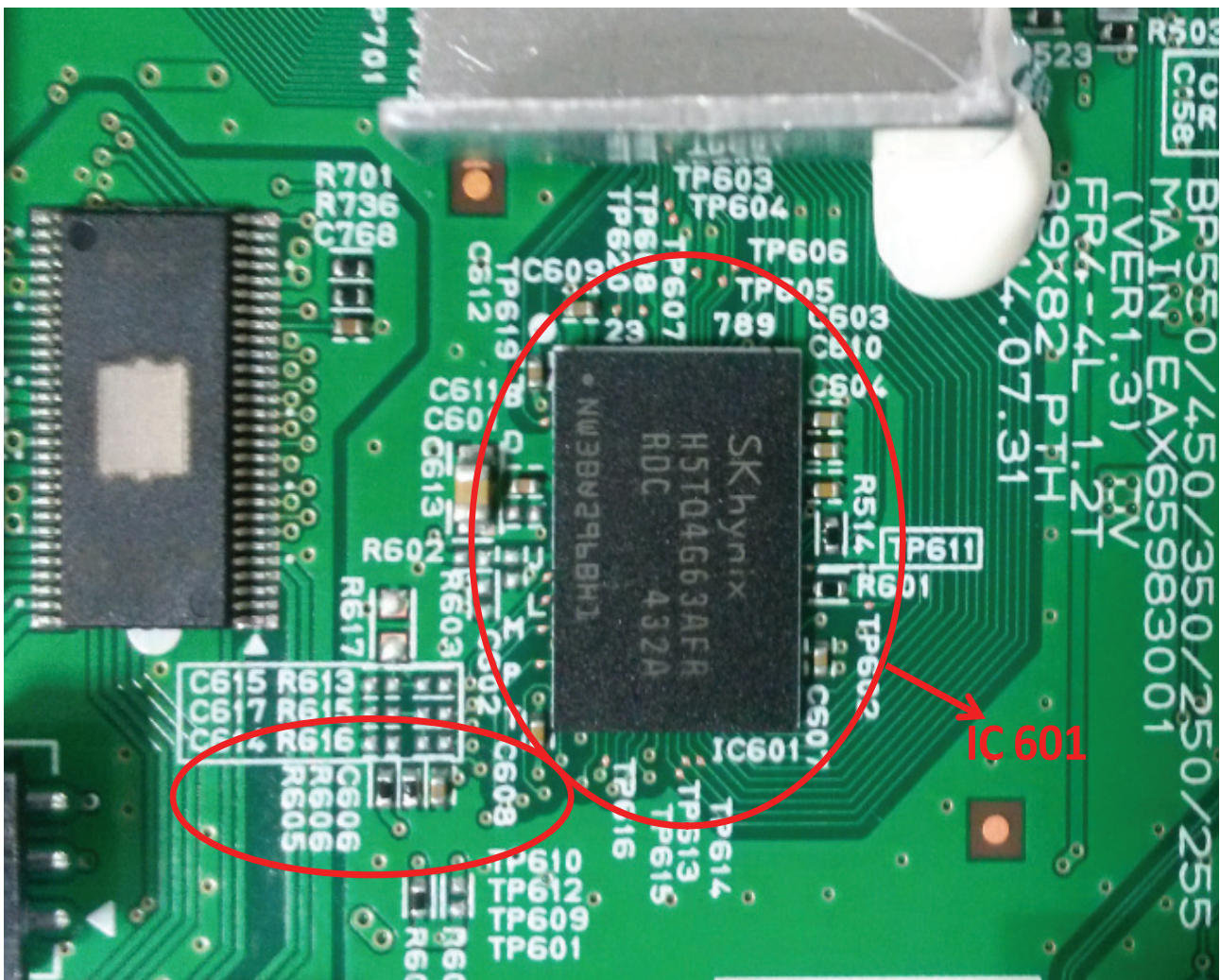

IC601, C606, R606  
< Main board top view >

# ONE POINT REPAIR GUIDE

## NO BOOTING WHEN YOU TURN THE UNIT ON

When you turn on your set, it will blank/ no displaying Main Menu on Television/ Monitor, and it will not boot-up.

### 3-8. IC501 (MPEG IC)

#### 3-8-1. Solution

Replace IC501 on main board.

#### 3-8-2. How to troubleshoot (Countermeasure)

- 1) Please check 1.2 V of C505, C506, and C507 on main board.  
Please check 3.3 V of C517 and C518 on main board.  
Please check 1.5 V of C515 and C516 on main board.
- 2) If it doesn't work even though IC150, IC151 are no problem, IC501 MPEG IC could have problem.
- 3) After changing it, if the set is still no booting, check main board refer to item 3-9.

#### 3-8-3. Service hint (Any picture / Remark)

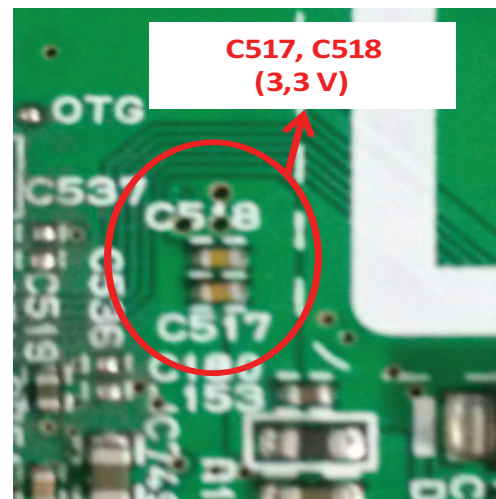
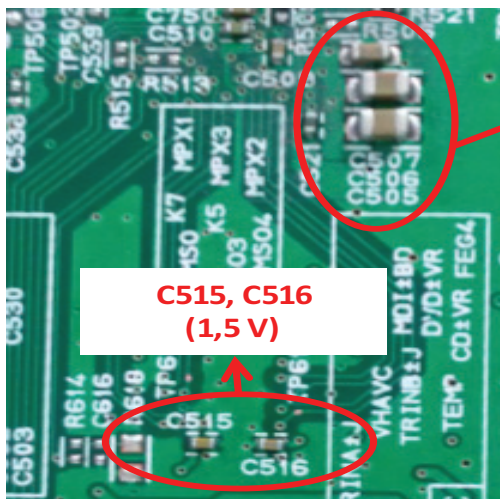

C505, C506, C507, C515, C516, C517, C518, IC501  
< Main board top view >

# ONE POINT REPAIR GUIDE

## NO BOOTING WHEN YOU TURN THE UNIT ON

When you turn on your set, it will blank/ no displaying Main Menu on Television/ Monitor, and it will not boot-up.

### 3-9. Main board

#### 3-9-1. Solution

Replace main board.

#### 3-9-2. How to troubleshoot (Countermeasure)

1) Please remove IC501 and IC601.

And then check the impedance between each signal (DATA, ADDRESS and so on).

2) If there is some impedance (a few ohm or infinite ohm) especially power source trace, PCB via might be broken. You'd better change main board.

#### 3-9-3. Service hint (Any picture / Remark)

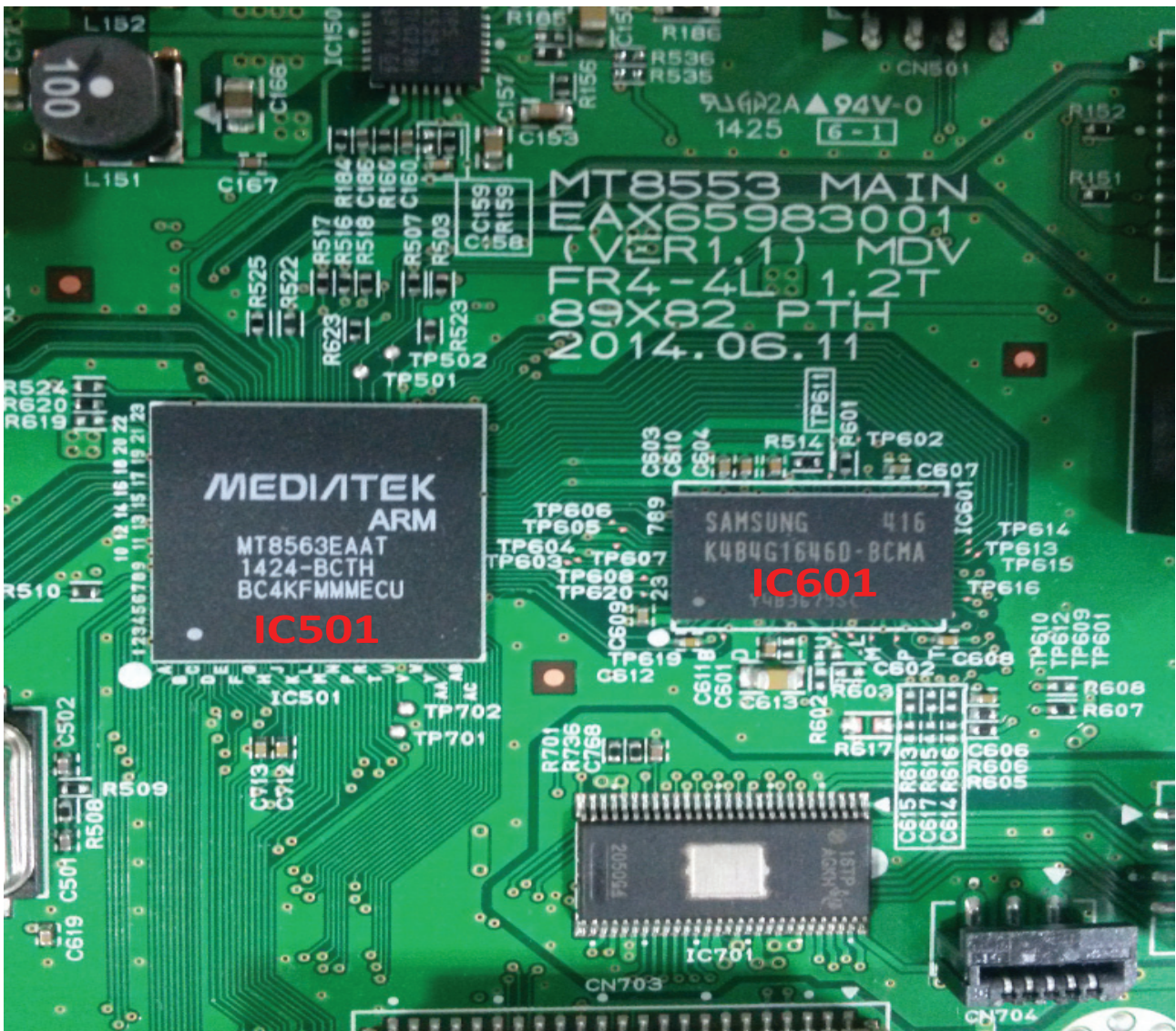

IC501 and IC601  
< Main board top view >

# ONE POINT REPAIR GUIDE

## 4. BAD HDMI VIDEO / AUDIO OUTPUT

When unit is connected to HDMI TV using HDMI cable, picture shows bad color, no output or mixed color on the screen. But component output is OK.

### 4-1. JK802 (HDMI Jack)

#### 4-1-1. Solution

Replace JK802 (HDMI Jack).

#### 4-1-2. How to troubleshoot (Countermeasure)

- 1) Check JK802 pin soldering.
- 2) If there is short soldering on pin JK802, re-soldering pin JK802.
- 3) If problem still occurs, check HDMI data:
  - If all data OK, replace JK802.
  - If data NG, check set on BD Mode:  
Replace IC501.

#### 4-1-3. Service hint (Any picture / Remark)



JK802  
< Main board top view >



JK802  
< Main board bottom view >

# ONE POINT REPAIR GUIDE

## 5. WIRED NETWORK CONNECTION ERROR - (OPTION PART)

When you connect online service (like Youtube or Netflix2.1) through the wired LAN, the “no connection” message appears.

### 5-1. JK803 (Ethernet Jack)

#### 5-1-1. Solution

Replace JK803 (Ethernet Jack) on main board.

#### 5-1-2. How to troubleshoot (Countermeasure)

- 1) Check you internet connection.  
Make sure it connect properly to modem or router.
- 2) If internet connection OK, please check the Ethernet Jack (JK803).
- 3) If there is soldering problem, please re-soldering pin JK803.
- 4) If after re-soldering problem still occurs, replace JK803.
- 5) If problem still occurs after change JK803, check MPEG IC (IC501).  
Refer to item 3-8.

#### 5-1-3. Service hint (Any picture / Remark)



JK803  
< Main board top view >

# ONE POINT REPAIR GUIDE

## 6. WIRELESS NETWORK CONNECTION ERROR - (OPTION PART)

When you connect online service (like Youtube or Netflix2.1) through the Wi-Fi, the “no connection” message appears.

### 6-1. Wi-Fi Module

#### 6-1-1. Solution

Replace Wi-Fi module.

#### 6-1-2. How to troubleshoot (Countermeasure)

- 1) Check you internet connection.  
Make sure it connect properly to modem or router.
- 2) If internet connection OK, please check the CN803.
- 3) If there is soldering problem, please re-soldering pin CN803.
- 4) If after re-soldering problem still occurs, Please check CN803 pin5 (Wi-Fi 5V)
- 5) If there is no 5 V, please check IC191 pin6 (5 V)
- 6) If IC191 pin abnormal, check C191, C192, C193, R192  
and there is no defective component, replace IC191.
- 7) After changing it, if the set is still no connection, replace Wi-Fi module.
- 8) If problem still occurs after change it, check MPEG IC (IC501).  
Refer to item 3-8.

#### 6-1-3. Service hint (Any picture / Remark)



CN803, < Main board top view >

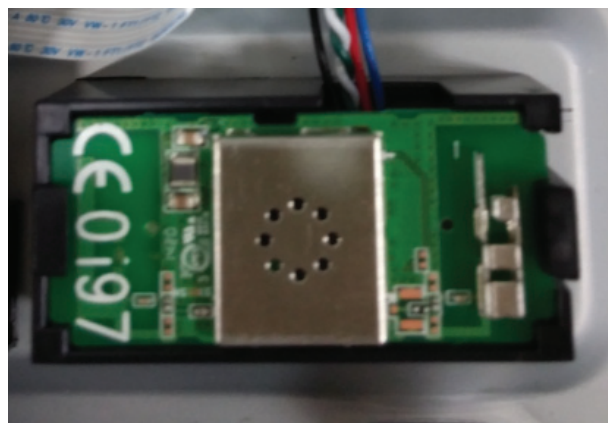

< Wi-Fi module >

# ELECTRICAL TROUBLESHOOTING GUIDE

## 1. POWER SUPPLY ON MAIN BOARD

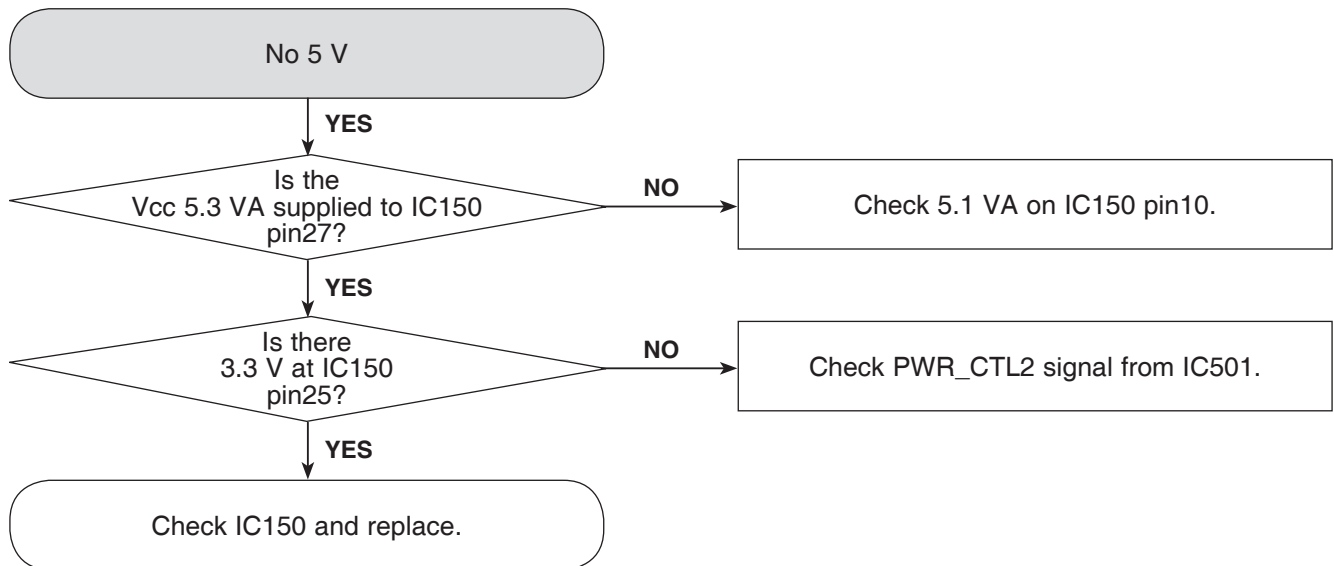
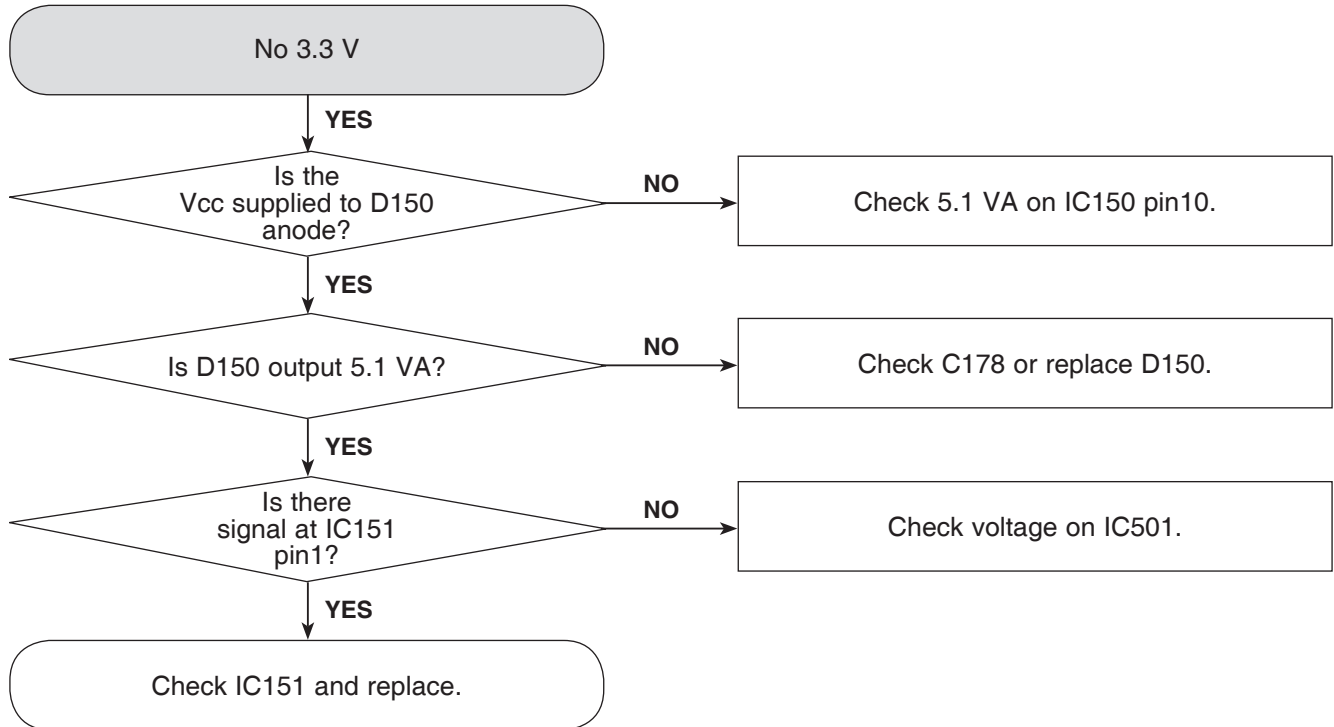



# ELECTRICAL TROUBLESHOOTING GUIDE

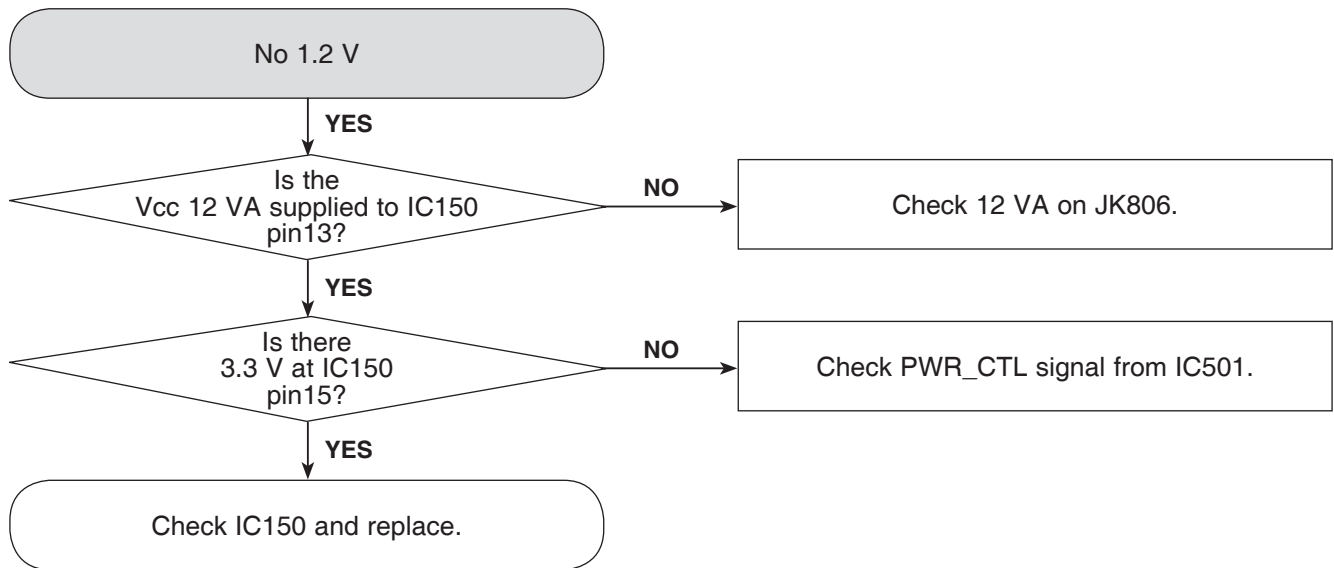
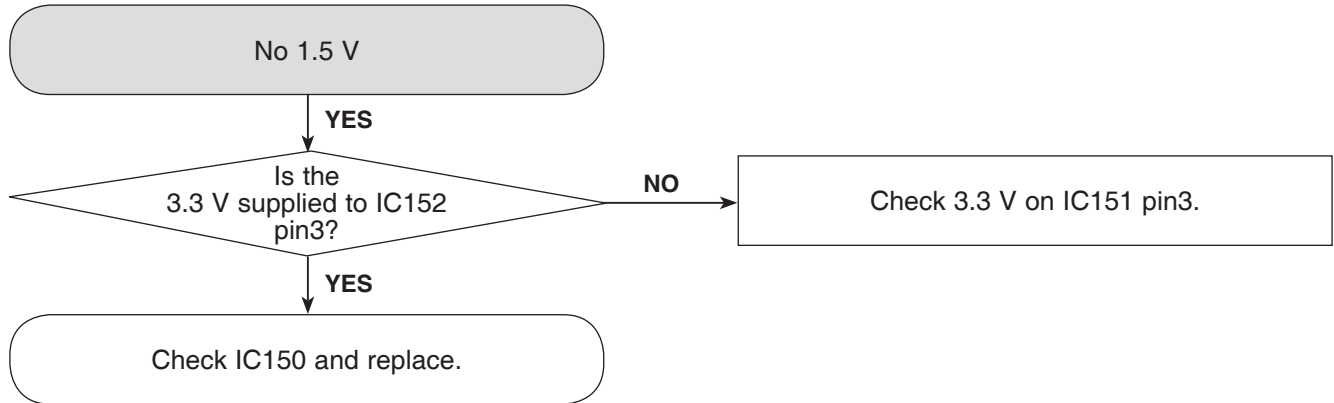

# ELECTRICAL TROUBLESHOOTING GUIDE

## 2. SYSTEM PART

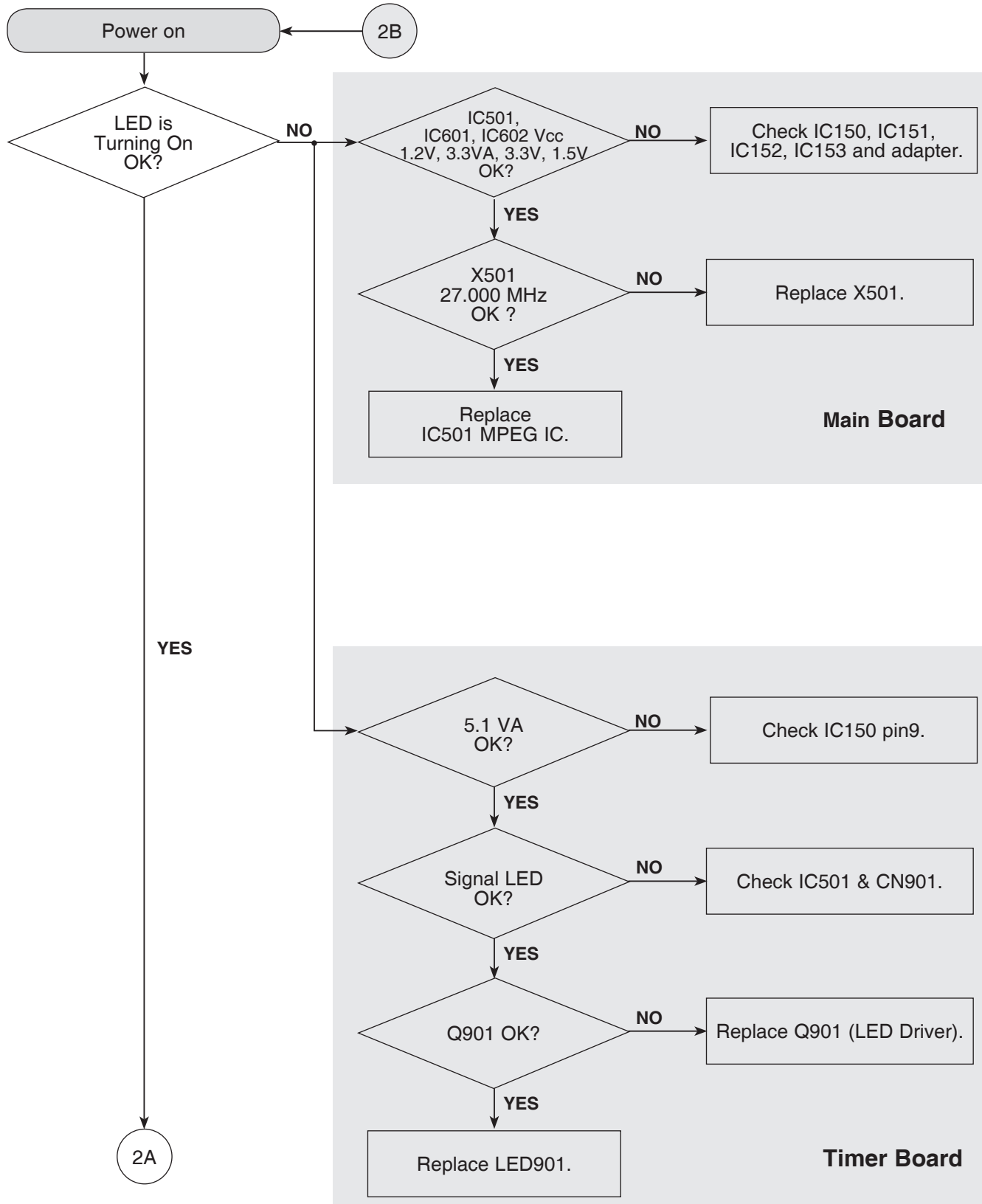

# ELECTRICAL TROUBLESHOOTING GUIDE

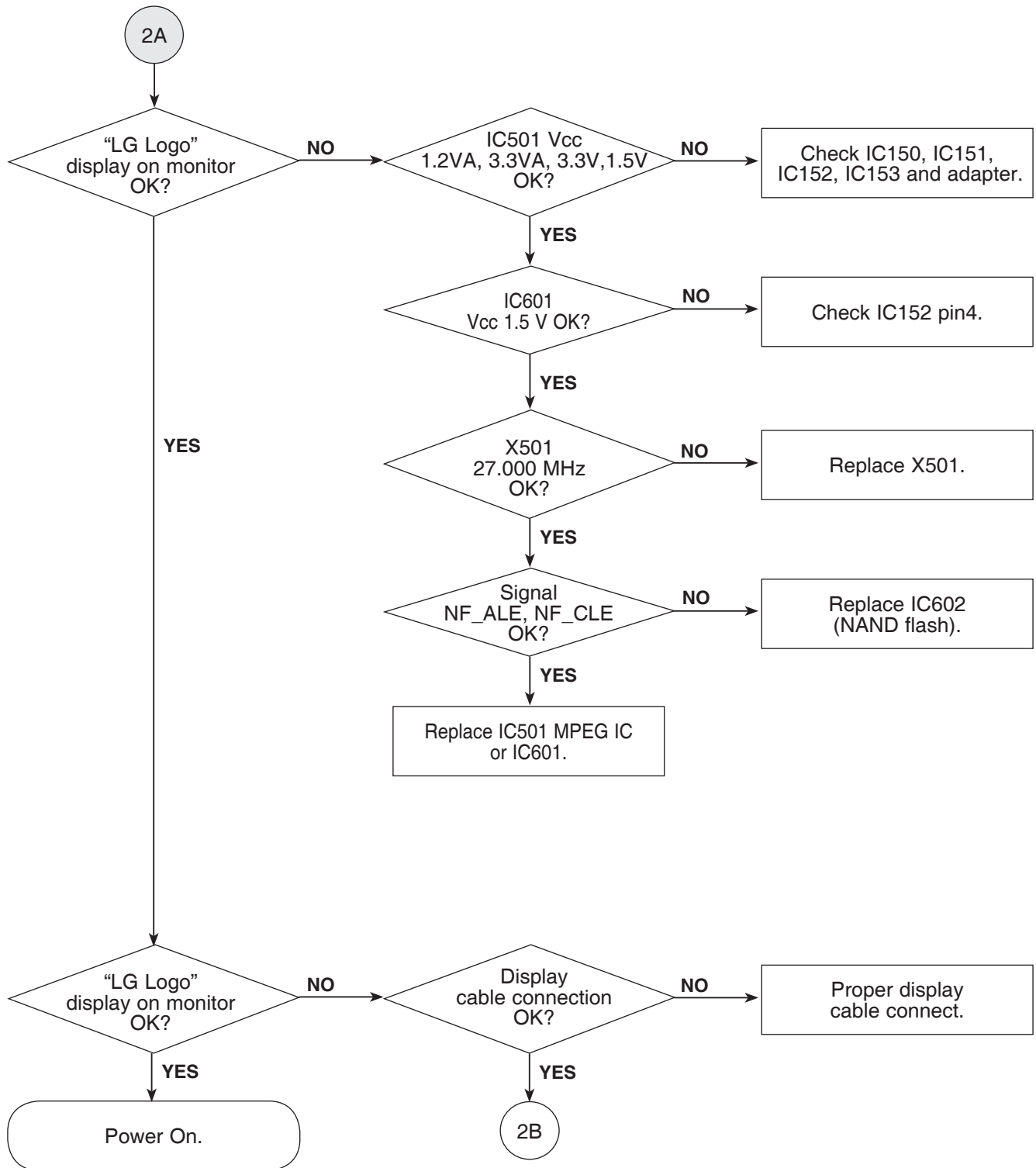

# ELECTRICAL TROUBLESHOOTING GUIDE

## 3. NO HDMI OUTPUT

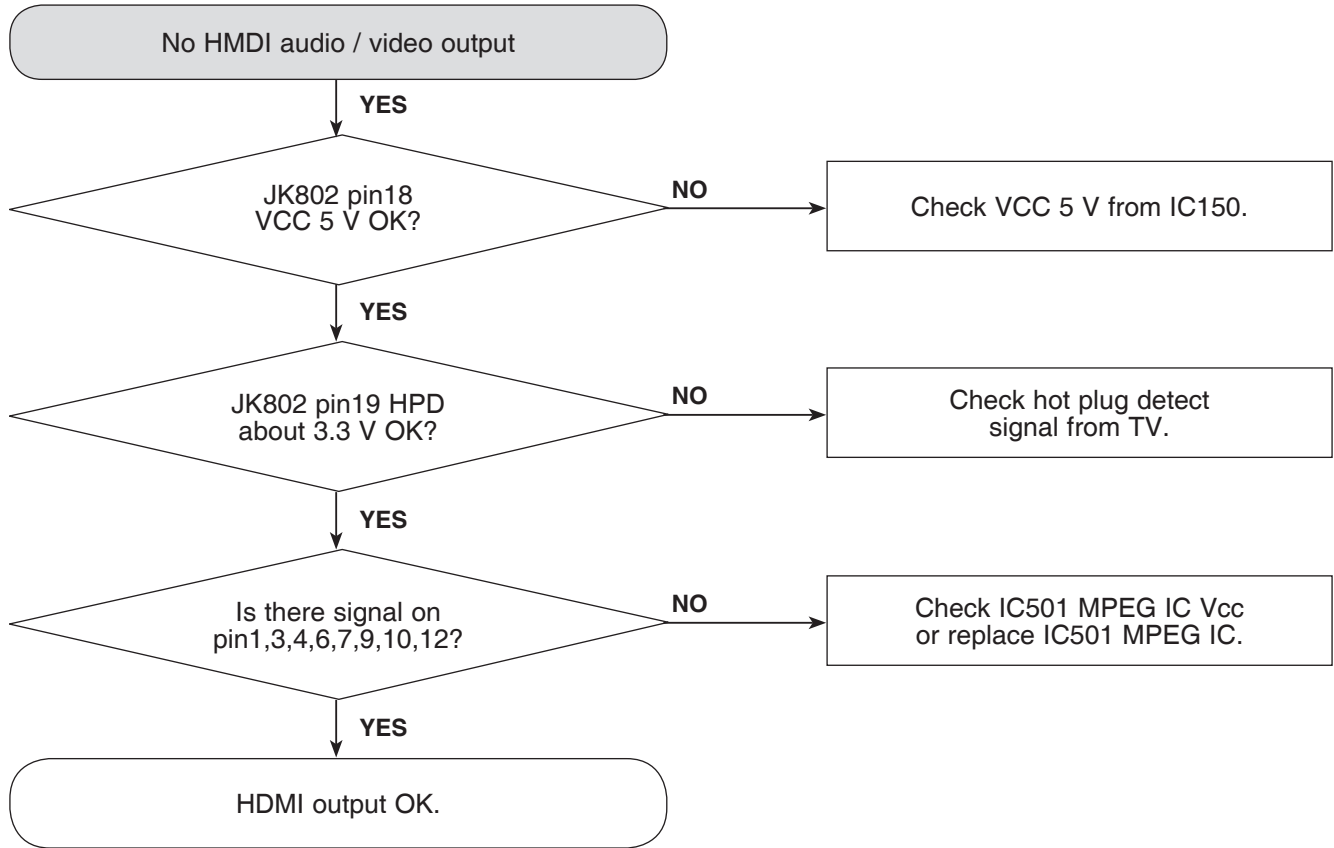

# WAVEFORMS OF MAJOR CHECK POINT

## 1. SYSTEM PART - 1

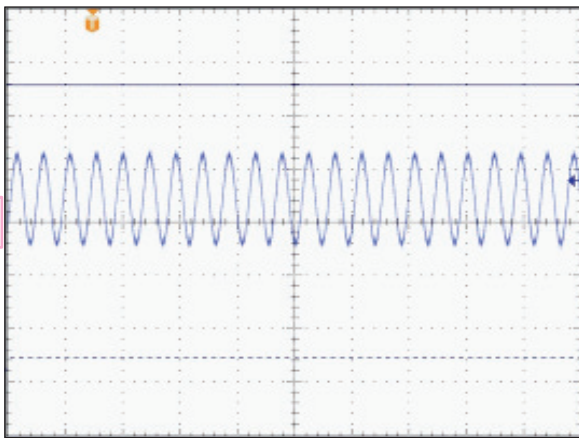
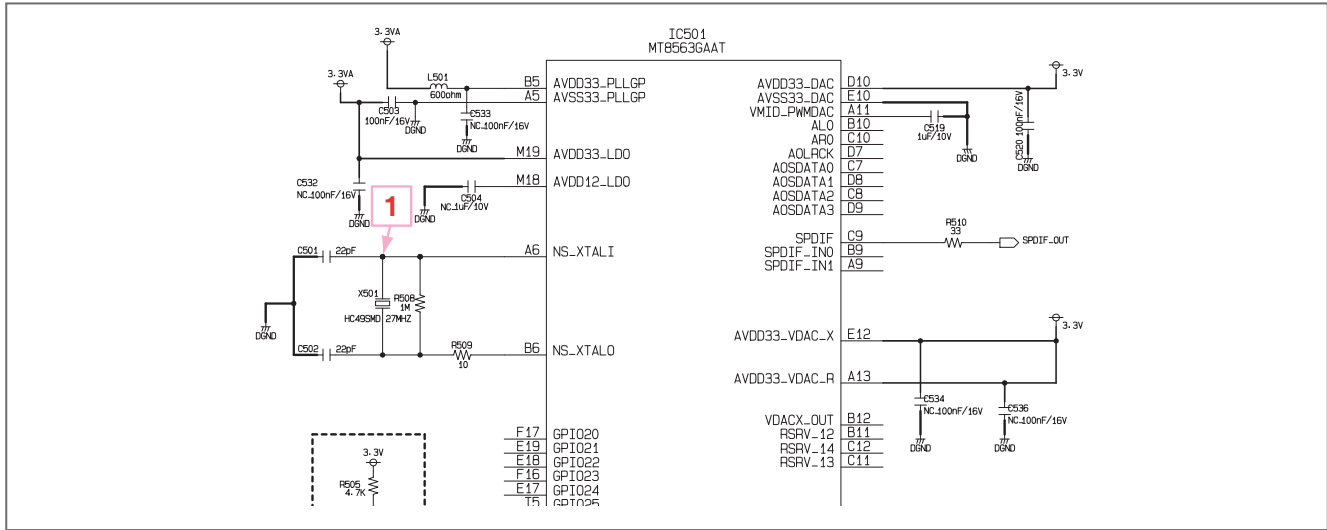

IC501 X-TAL 27 MHz

## 2. SYSTEM PART - 2 (SYSTEM MEMORY)

2

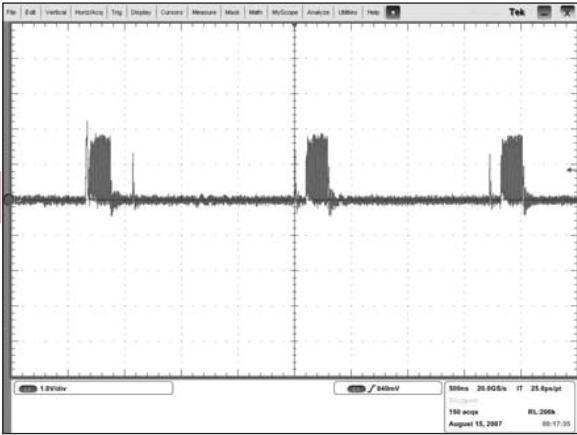

IC601 BA0

3

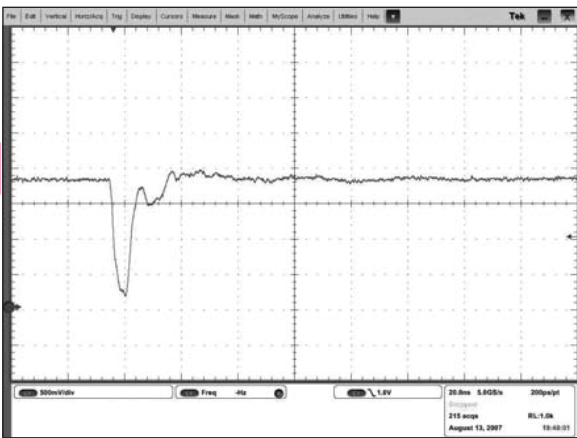

IC601 WE#

4

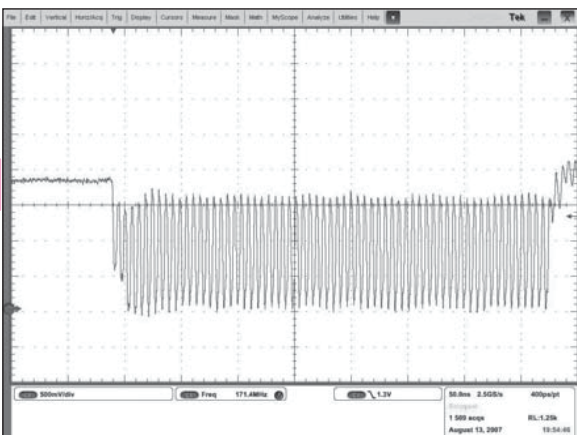

IC601 CAS#

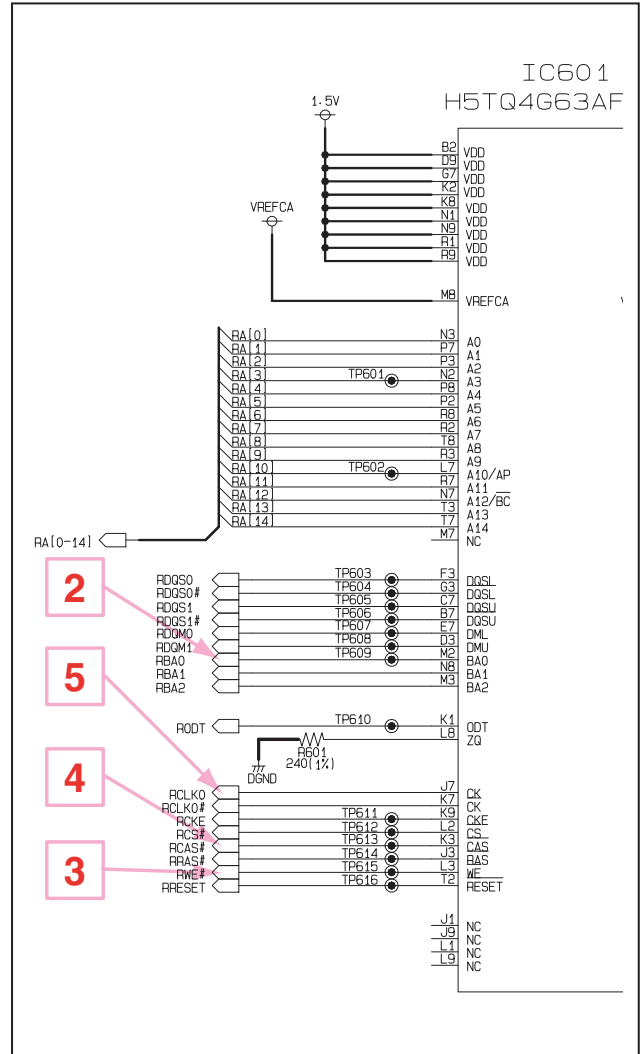

5

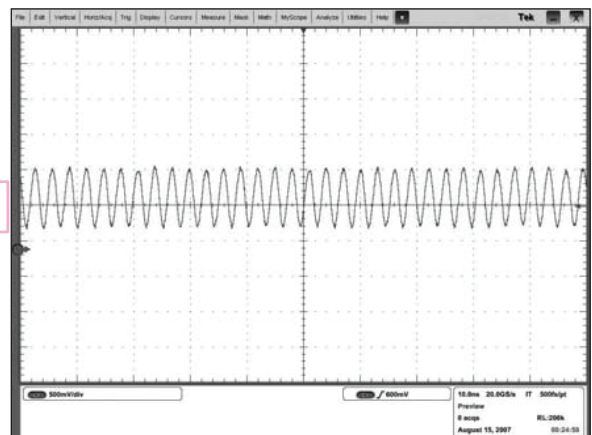

IC601 CK

### 3. HDMI PART

6

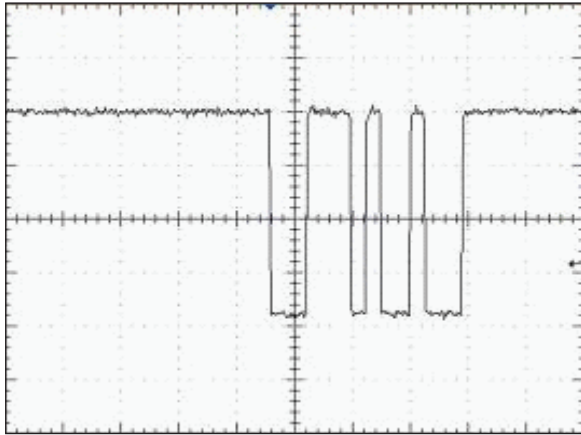

H\_SDA

7

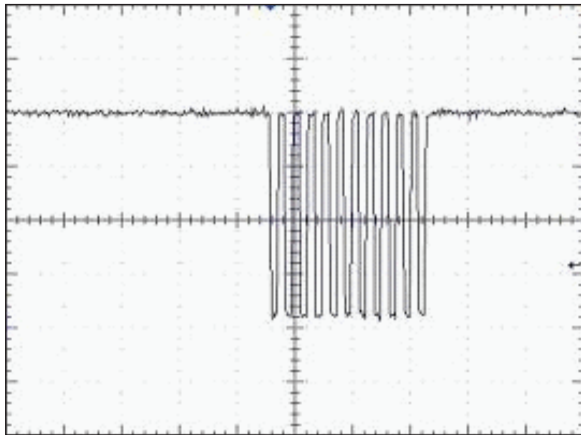

H\_SCL

8

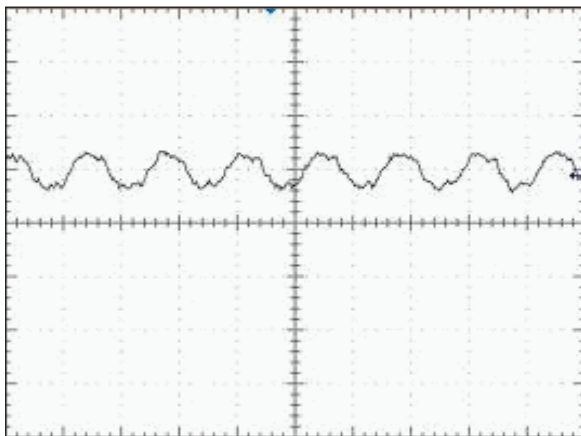

HDMI\_CLK\_N

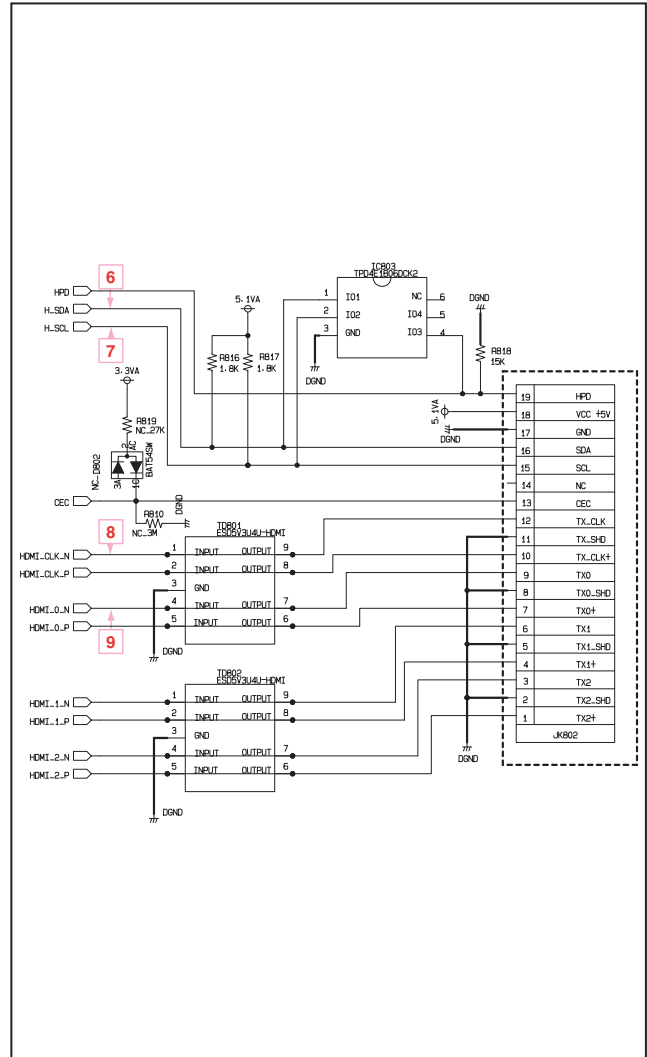

9

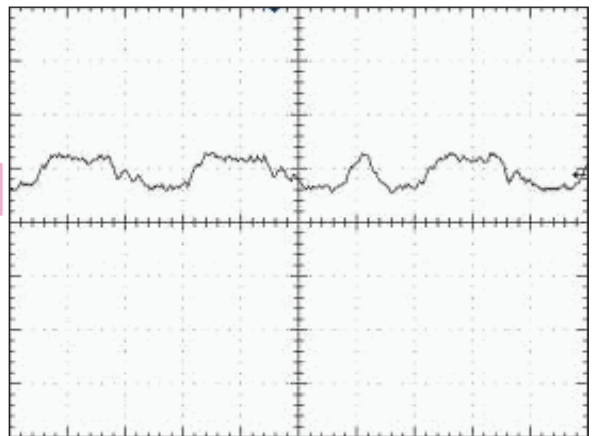

HDMI\_0\_N

# WIRING DIAGRAMS

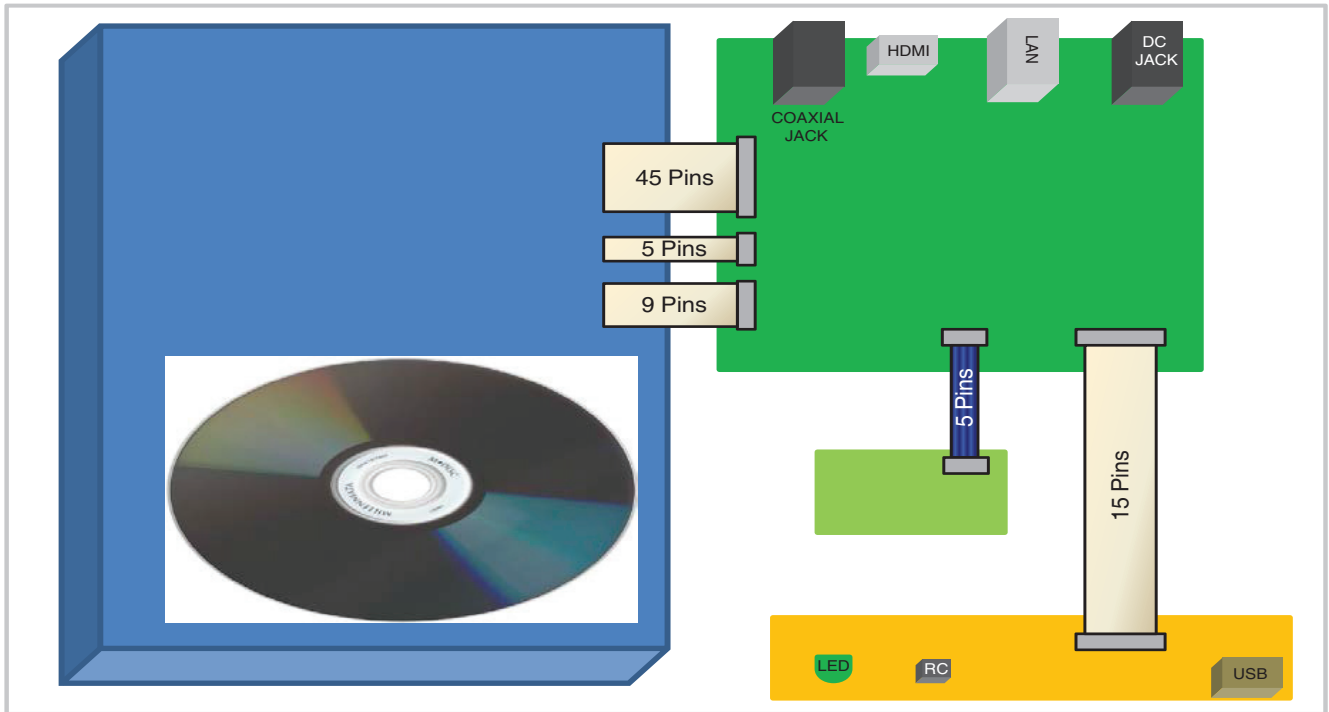



# BLOCK DIAGRAM

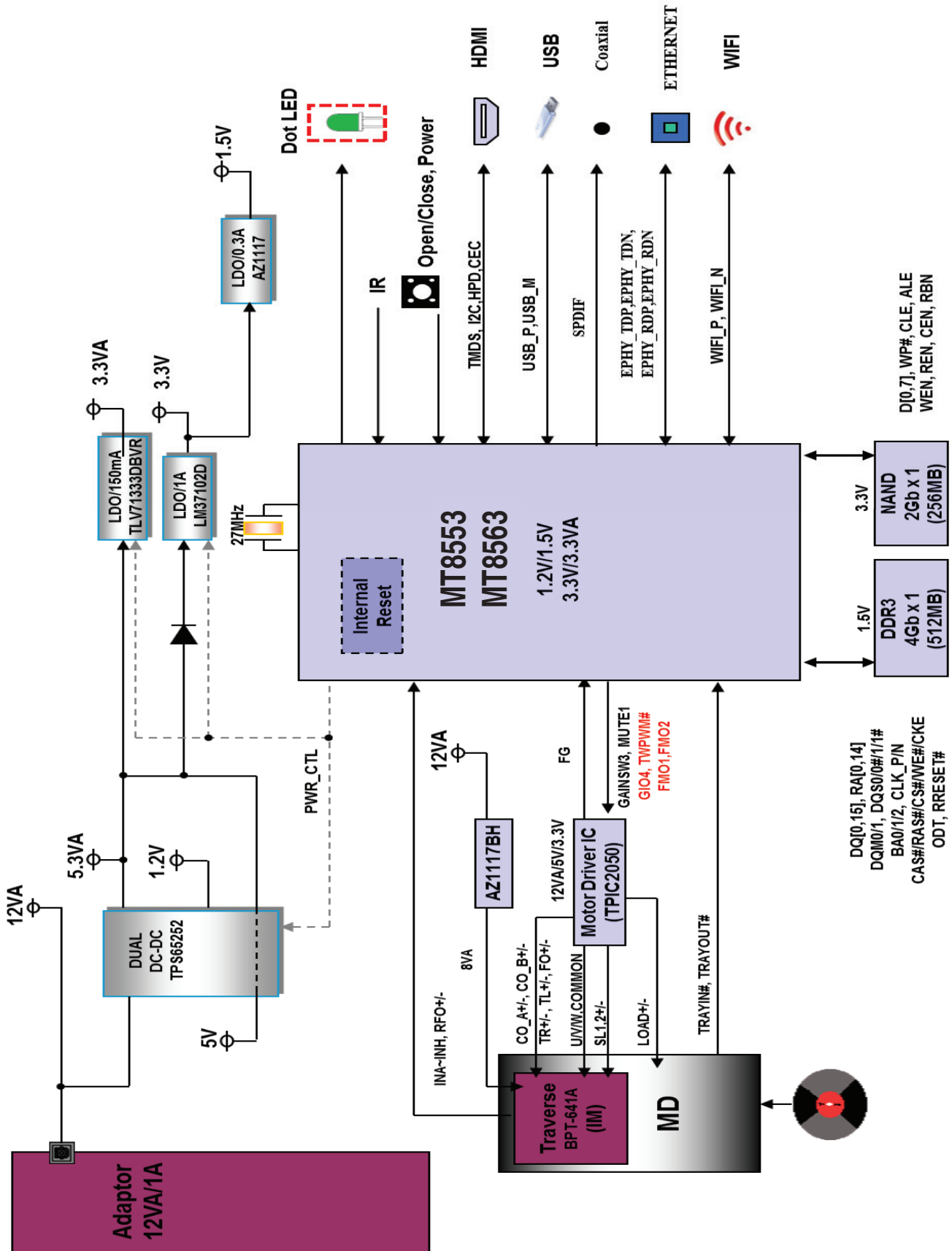





# SECTION 4

## MT8553 / MT8563

### FRONT-END LOADER PART

#### (SONY OPU)

## CONTENTS

<b>LD CHECK GUIDE</b> .....	4-2
1. PURPOSE.....	4-2
2. LD CHECK PROCEDURE .....	4-2
<b>BARCODE SCAN GUIDE</b> .....	4-3
1. PURPOSE.....	4-3
2. REQUIRED TO INSERT NEW BARCODE VALUE.....	4-3
3. METHOD.....	4-3
4. PROCEDURE .....	4-3
<b>MAJOR IC INTERNAL BLOCK DIAGRAM AND PIN DESCRIPTION</b> .....	4-6
1. MT8553 / MT8563 PIN DESCRIPTION .....	4-6
2. IC701 (TPIC2050): 9CH MOTOR DRIVE WITH 3 BEAM LASER DIODE DRIVER .....	4-9
3. PICK-UP CONNECTOR TERMINAL PIN ASSIGNMENTS.....	4-11
<b>BLOCK DIAGRAM</b> .....	4-12

# LD CHECK GUIDE

## 1. PURPOSE

If LD (Laser Diode) have problem, disc reading problem can happen.  
So it is needed to check LD status.

## 2. LD CHECK PROCEDURE

1) Power on the set.

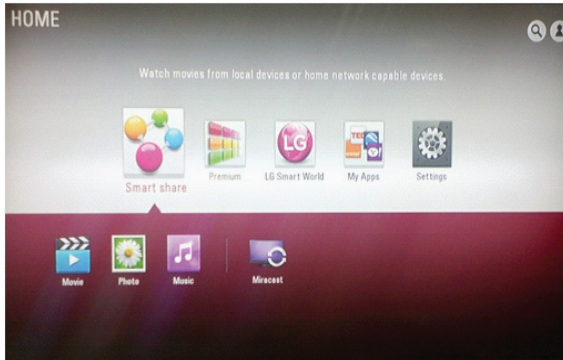

4) Check result is shown automatically.

If you will see **"PASS"**, BD/DVD/CD LD status is OK.

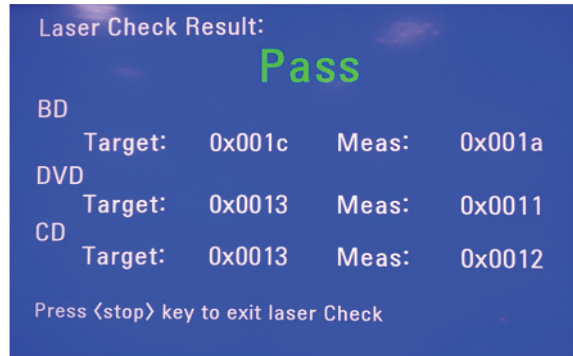

2) Press Settings.

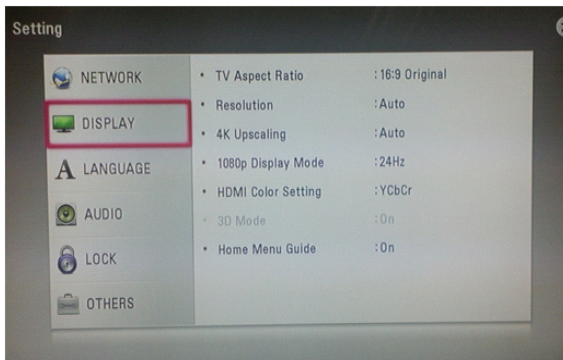

3) Under DISPLAY highlighted condition, press '5' -> '1' -> '7' -> '7' -> '7' -> '7' -> Enter on the remote controller to display special mode. Move to the [1]Laser Check and click.

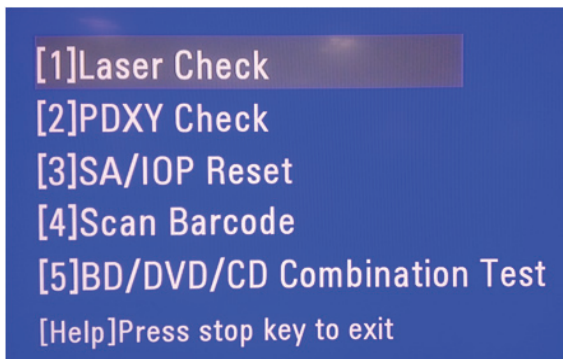

# BARCODE SCAN GUIDE

## 1. PURPOSE

We have to scan barcode of SONY OPU and save barcode information into main PCB to read disc well because this barcode includes different optimal value according to OPU.  
So we have to use matched barcode.

## 2. REQUIRED TO INSERT NEW BARCODE VALUE

- After changing traverse.
- After changing main board assembly.
- After changing main board flash IC.

## 3. METHOD

There are 2 ways to save barcode information.

- 1) Use 2D barcode scanner. ( If there is 2D barcode scanner, use this method. )
- 2) Save default barcode information into USB.

## 4. PROCEDURE

### 4-1. Use 2D barcode scanner

- 1) Power on the set.

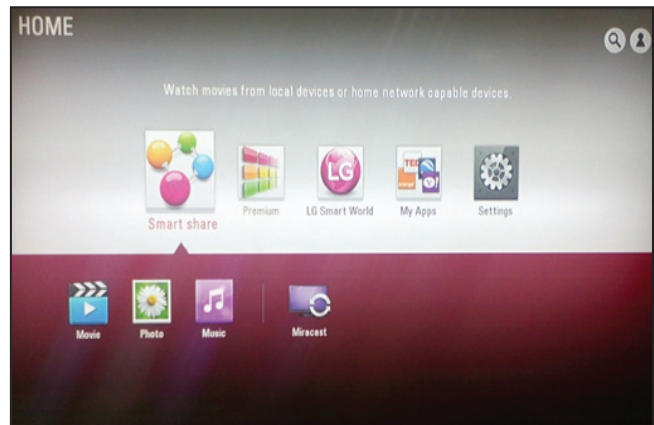

- 2) Press settings.

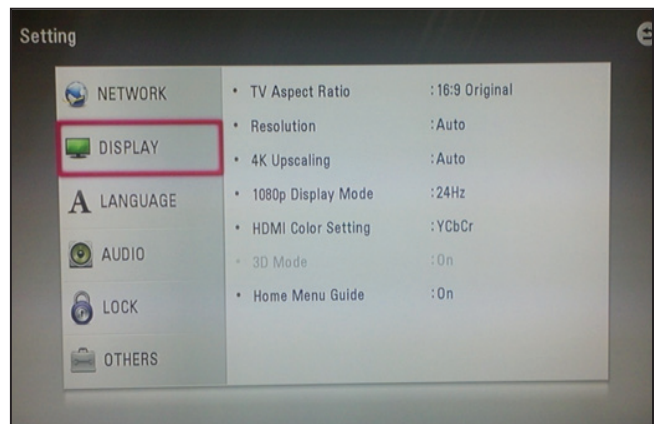

3) Under DISPLAY highlighted condition, press '5' -> '1' -> '7' -> '7' -> '7' -> '7' -> '7' -> 'Enter' on the remote controller to display special mode. Move to the [4]Scan Barcode and click.

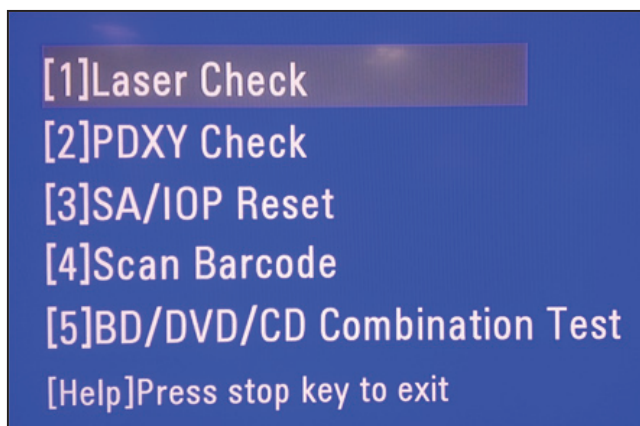

4 ) Connect Barcode Scanner with USB port and read barcode.

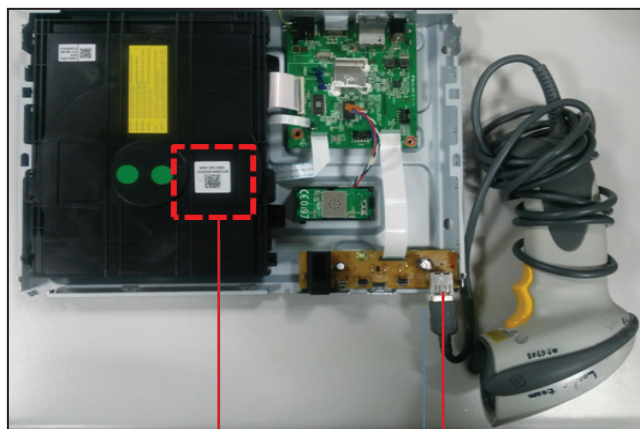

Barcode  
Connect Barcode Scanner with USB port.

5 ) If barcode scan result is OK, it is shown as right figure.

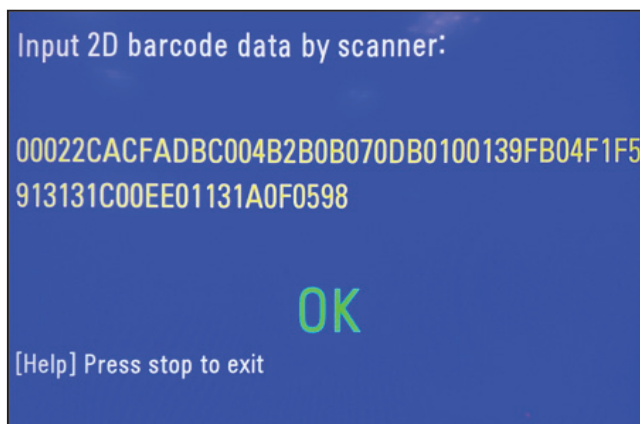

## 4-2. Use USB

- 1) Copy DEFAULT\_BARCODE Folder into USB.  
The folder include txt file as right figure.

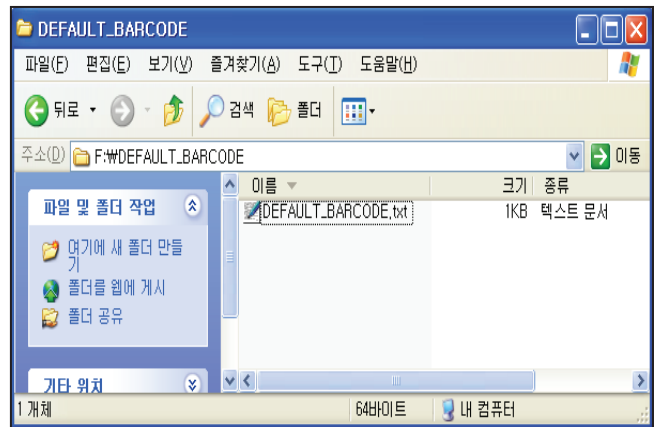

- 2) Power on the set.

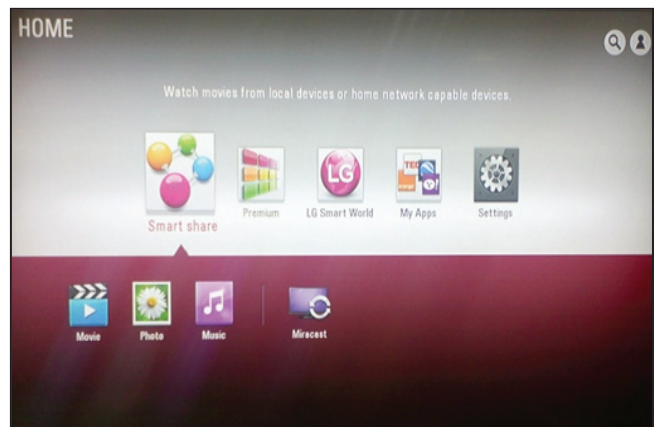

- 3) Insert USB with the set and If USB is recognized, barcode is downloaded automatically.

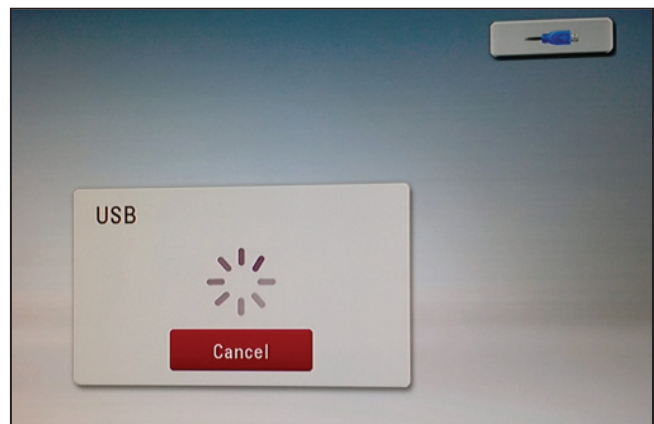



# MAJOR IC INTERNAL BLOCK DIAGRAM AND PIN DESCRIPTION

## 1. MT8553 / MT8563 PIN DESCRIPTION

### 1-1. Pin Function

PIN NO.	SYMBOL	TYPE	DESCRIPTION
SERVO			
E4	AUX1	Analog I/O	Auxiliary Input. Alternate Function : Signal Monitoring
F6	AVDD12	Analog Power(1.2V)	Power Pin
D6	AVDD33_1	Analog Power(3.3V)	Power Pin
E7	AVDD33_3	Analog Power(3.3V)	Power Pin

K1	FECFREQ	3.3V LVTTTL I/O, 5V-tolerance, Slow slew, 2, 4, 6, 8 mA PDR, 75K pull-up (3.3 V)	Frequency selection signal output, or LDD serial interface data or 12C SDA. The pin is spike-free at power-on stage.
K3	FECMOD	3.3V LVTTTL I/O, 5V-tolerance, Slow slew, 2, 4, 6, 8 mA PDR, 75K pull-up (0 V)	High frequency modulation mode selection signal output, or LDO serial interface command enable. The pin is spike-free at power-on stage.  Multifunction: Line-in input data
L6	FEDMO	Analog Output	Disk motor control output. DAC output.
L2	FEEJECT_	3.3V LVTTTL I/O, 5V-tolerance, 6 mA driving, 75K pull-up (3.3 V)	Eject/stop key input, active low. The pin is spike-free at power-on stage. Alternate function : General IO.
P4	FEFG	3.3V LVTTTL I/O, 5V-tolerance, 6 mA PDR, 75K pull-up (3.3 V)	Motor Hall sensor input. The pin is spike-free at power-on stage.
N2	FEFMO	Analog Output	Feed motor 1 control. DAC output.
N3	FEFMO2	Analog Output	Feed motor 2 control. DAC output.
L5	FEFMO3	Analog I/O	Feed motor 3 control. DAC output. Alternative Function : Auxiliary servo input.
L4	FEFMO4	Analog I/O	Feed motor 4 control. DAC output. Alternative Function : Auxiliary servo input.
H3	FOO	Analog Output	Focus servo output. PDM output of focus servo compensator.
A4	FPDOCD	Analog Input	Laser Power Monitor Input for CD APC / Differential negative input
B4	FPDODVD	Analog Input	Laser Power Monitor Input for DVD APC / Differential positive input
J2	FEGAINSW1	Analog Output	Read gain switch 1.
J3	FEGAINSW2	Analog Output	Read gain switch 2.
P2	FEGAINSW3	Analog Output	Read gain switch 3.
M2	FEGIO0	3.3V LVTTTL I/O, 5V-tolerance, 2, 4, 6, 8 mA PDR, 75K pull-down (0 V)	LDD serial interface data. The pin is spike-free at power-on stage. The pin is not allowed to pull-up in circuit layout. Alternate function : 1. Internal monitored signal output 2. General IO
K4	FEGIO1	3.3V LVTTTL I/O, 5V-tolerance, 2, 4, 6, 8 mA PDR, 75K pull-down (0 V)	LDD serial interface CLK. The pin is spike-free at power-on stage. The pin is not allowed to pull-up in circuit layout. Alternate function : 1. Internal monitored signal output 2. General IO

PIN NO.	SYMBOL	TYPE	DESCRIPTION
R2	FEGIO10	3.3V LVTTTL I/O, 5V-tolerance, 2, 4, 6, 8 mA PDR, 75K pull-down (3.3 V)	PC RS232 serial receive data. The pin is spike-free at power-on stage. Alternate function : 1. High speed serial output port. (CLOCK) 2. Internal monitored signal output 3. LED Control Output. Initial "0" Output 4. Line-in input master clock 5. Serial interface control line 6. Slave I2C clock 7. General IO
R3	FEGIO11	3.3V LVTTTL I/O, 5V-tolerance, 2, 4, 6, 8 mA PDR, 75K pull-down (3.3 V)	PC RS232 serial transmit data. The pin is spike-free at power-on stage. Alternate function : 1. High speed serial output port. (Data) 2. Internal monitored signal output 3. Line-in input bit clock 4. Serial interface control line 5. Slave I2C clock 6. General IO
N4	FEGIO3	3.3V LVTTTL I/O, 5V-tolerance, 2, 4, 6, 8 mA PDR, 75K pull-down (0 V)	LED Control Output. Initial 0 Output. The pin is spike-free at power-on stage. Alternate function : 1. Internal monitored signal output 2. General IO
P1	FEGIO4	Analog Output	Read gain switch 4 Alternate function : 1. LCD serial interface command enable. 2. LCD_DRV: Square wave output for LCD control. 3. Internal monitored signal output 4. Line-in input left-right clock 5. General IO.
J1	FEGIO5	Analog Output	Read gain switch 6 Alternate function : 1. SIDM 2. LCD serial interface command enable. 3. Internal monitored signal output 4. Line-in input data 5. General IO.
K7	FEGIO6	Analog Output	Read gain switch 6. The pin is not allowed to pull-up in circuit layout Alternate function : 1. SIDM 2. LCD serial interface command enable. 3. Internal monitored signal output 4. General IO.
K5	FEGIO7	3.3V LVTTTL I/O, 5V-tolerance, 2, 4, 6, 8 mA PDR, 75K pull-down (0 V)	General IO. The pin is spike-free at power-on stage. The pin is not allowed to pull-up in circuit layout.
K6	FEGIO9	3.3V LVTTTL I/O, 5V-tolerance, 2, 4, 6, 8 mA PDR, 75K pull-down (0 V)	General IO. The pin is spike-free at power-on stage. Alternate function : 1. Internal monitored signal output 2. Spoke input 3. Power on reset input, high active. 4. General IO.
D5	HAVC	Analog Output	Decoupling Pin for Reference Voltage of Main and Sub Beams
A1	INA	Analog Input	Input of Main Beam Signal (A)
B2	INB	Analog Input	Input of Main Beam Signal (B)
B1	INC	Analog Input	Input of Main Beam Signal (C)

PIN NO.	SYMBOL	TYPE	DESCRIPTION
C3	IND	Analog Input	Input of Main Beam Signal (D)
D2	INE	Analog Input	Input of Sub-Beam Signal (E)
D3	INF	Analog Input	Input of Sub-Beam Signal (F)
C2	ING	Analog Input	Input of Sub-Beam Signal (G)
C1	INH	Analog Input	Input of Sub-Beam Signal (H)
G6	MPXOUT1	Analog Output	Multiplexer Output 1 for Signal Monitoring. The pin is not allowed to pull-up in circuit layout. Alternate function : Internal monitored signal output / General output.
G5	MPXOUT2	Analog Output	Multiplexer Output 2 for Signal Monitoring. The pin is not allowed to pull-up in circuit layout. Alternate function : Internal monitored signal output / General output.
F4	MPXOUT3	Analog Output	Multiplexer Output 3 for Signal Monitoring. The pin is not allowed to pull-up in circuit layout. Alternate function : Internal monitored signal output / General output.
K2	FEOSCEN	3.3V LVTTL I/O, 5V-tolerance, Slow slew, 2, 4, 6, 8 mA PDR, 75K pull-up (3.3 V)	High frequency modulation enable signal output, or LDD serial interface CLK or 12C SCL. The pin is spike-free at power-on stage.
G1	RFIN	Analog Input	Differential Input of AC Coupling RF SUM Signal (Negative)
G2	RFIP	Analog Input	Differential Input of AC Coupling RF SUM Signal (Positive)
G3	TLO	Analog Output	Tilt servo output
M1	FETRAYIN_	3.3V LVTTL I/O, 5V-tolerance, 6 mA, 75K pull-up (3.3 V)	Tray_is_in Input. A Logical Low Indicates the Tray is IN. Feedback Flag is from Tray Connector. The pin is spike-free at power-on stage. Alternate function : General IO.
L3	FETRAYOUT_	3.3V LVTTL I/O, 5V-tolerance, 6 mA, 75K pull-up (3.3 V)	Tray_is_out Input. A Logical Low Indicates the Tray is OUT. Feedback Flag is from Tray Connector. The pin is spike-free at power-on stage. Alternate function : General IO.
P3	FETRAYPWM	Analog Output	Tray DAC / PWM control output. Controlled by microP
E1	TRINA	Analog Input	Input of Tracking Signal (A)
E2	TRINB	Analog Input	Input of Tracking Signal (B)
F3	TRINC	Analog Input	Input of Tracking Signal (C)
F2	TRIND	Analog Input	Input of Tracking Signal (D)
H4	TRO	Analog Output	Tracking servo output. PDM output of tracking servo compensator.
E3	V14	Analog Output	Output of voltage eference (1.4V)
A2	VDAC0	Analog Output	Output of General DAC
A3	FVREF	Analog Output	Output of Voltage Reference
C4	VWDC2O	Analog Output	Output Voltage 2 of Laser Diode Control in APC
B3	VWDC3O	Analog Output	Output Voltage 3 of Laser Diode Control in APC

## 2. IC701 (TPIC2050)

### : 9ch motor drive with 3 beam laser diode driver

#### 2-1. Block Diagram

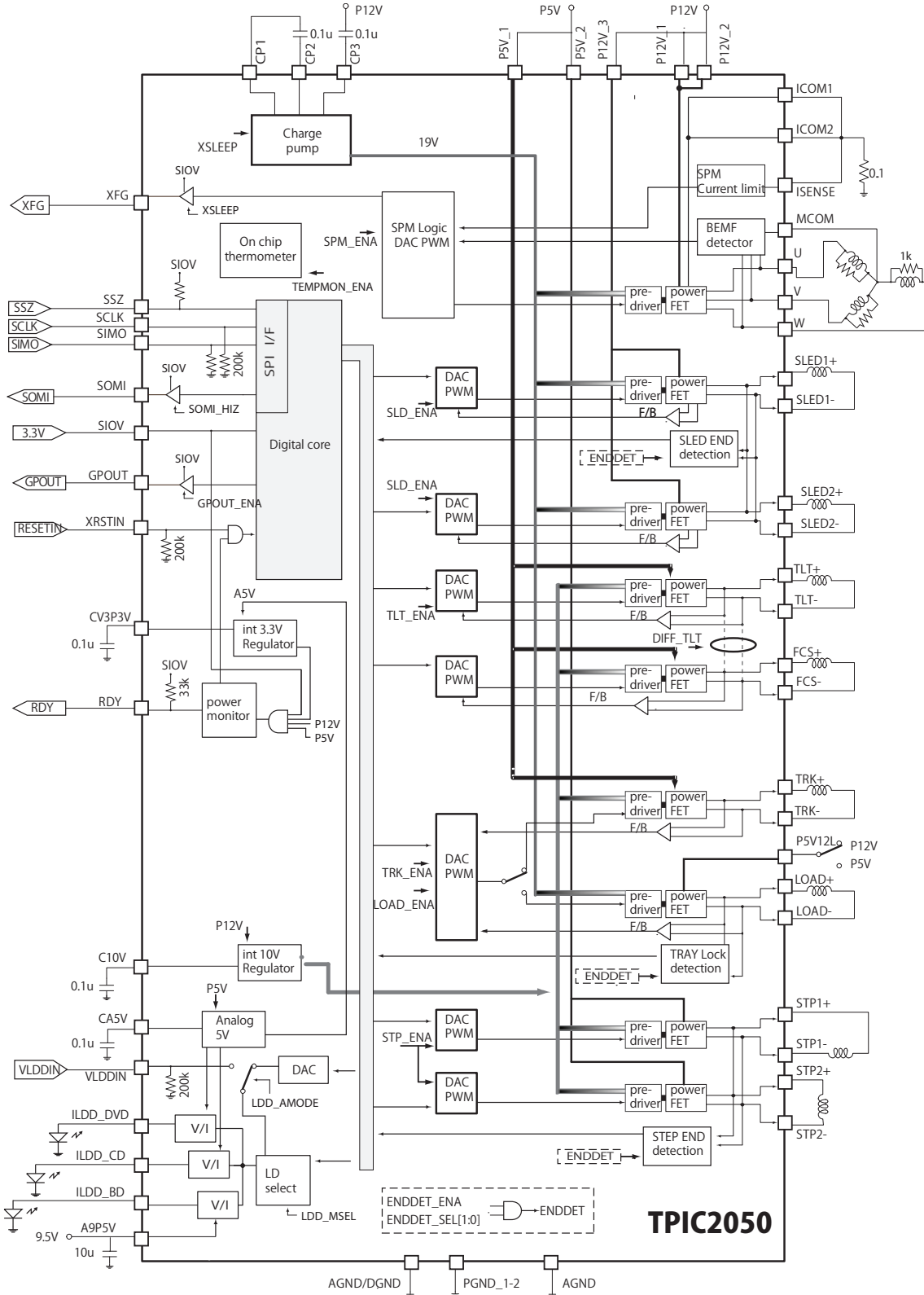

## 2-2. Pin Function

No.	Name	I/O	Description
1	SLED1_P	OUT	Sled1 positive output terminal
2	SLED1_N	OUT	Sled1 negative output terminal
3	P12V_3	PS	Power supply terminal for 12V drivers output
4	SLED2_P	OUT	Sled2 positive output terminal
5	SLED2_N	OUT	Sled2 negative output terminal
6	PGND_2	PS	GND terminal for 12V drivers
7	C10V	MISC	The capacitance connection terminal for internal regulator
8	CP1	MISC	Capacitance connection for Charge Pump
9	CP2	MISC	Capacitance connection for Charge Pump
10	CP3	MISC	Capacitance connection for Charge Pump
11	GPOUT	OUT	General Purpose Output (Test monitor)
12	XFG	OUT	Motor speed signal output
13	RDY	OUT	Device ready signal Internally pulled up to SIOV
14	SSZ	IN	SIO Slave Select Low active input terminal
15	SCLK	IN	SIO Serial clock input terminal
16	SIMO	IN	SIO Slave Input Master Output terminal
17	SOMI	OUT	SIO Slave Input Master Input terminal
18	SIOV	PS	Power supply terminal for Serial Port 3.3V typical
19	XRSTIN	IN	RESET input terminal to disable the driver IC
20	TEST1	MISC	Test pin. Should be open.
21	VLDDIN	IN	Laser diode control analog signal input 0 to 3V terminal. Required to set register when use VLDDIN input. Open in case of non use analog input.
22	CV3P3	MISC	Capacitance terminal for internal 3.3V core (typ 0.1uF)
23	AGND/DGND	PS	Ground terminal for digital and analog
24	A9P5V	PS	Power supply terminal 9.5V Laser diode for BD
25	ILDD_BD	OUT	Laser diode for BD output terminal
26	ILDD_DVD	OUT	Laser diode for DVD output terminal
27	ILDD_CD	OUT	Laser diode for CD output terminal
28	CP5V	MISC	The capacitance connection terminal for control system power supply 0.1uF or larger decoupling capacitor should be connected.
29	LOAD_P	OUT	Load positive output terminal
30	LOAD_N	OUT	Load negative output terminal
31	P5V12L	PS	The power supply terminal (5V or 12V) for Load driver output stages.
32	TEST2	MISC	Test pin. Should be open.
33	TEST3	MISC	Test pin. Should be connected to P5V.
34	P5V_1	PS	Power supply terminal for Tilt/Fcs/Trk drivers
35	TLT_N	OUT	Tilt negative output terminal
36	TLT_P	OUT	Tilt positive output terminal
37	TRK_P	OUT	Tracking positive output terminal
38	TRK_N	OUT	Tracking negative output terminal
39	FCS_P	OUT	Focus positive output terminal
40	FCS_N	OUT	Focus negative output terminal
41	PGND_1	PS	GND terminal for Tilt/Fcs/Trk channel drivers
42	P12V_1	PS	Power supply terminal for 12V driver output stage
43	U	OUT	U phase output terminal for spindle motor
44	ICOM1	MISC	Current sense resistor terminal for spindle driver
45	V	OUT	V Phase output terminal for spindle motor
46	P12V_2	PS	Power supply terminal for 12V driver output stage
47	W	OUT	W phase output terminal for spindle motor
48	ICOM2	MISC	Current sense resistor terminal for spindle driver
49	MICOM	IN	Motor center tap connection
50	ISENCE	IN	Current sense input terminal for spindle drivers
51	AGND	PS	Ground terminal for internal analog
52	STIP1_P	OUT	STP1 positive output terminal for collimator
53	STIP1_N	OUT	STP1 negative output terminal for collimator
54	STP2_P	OUT	STP2 positive output terminal for collimator
55	STP2_N	OUT	STP2 negative output terminal for collimator
56	P5V_2	PS	Power supply terminal for 5V driver output

### 3. PICK-UP CONNECTOR TERMINAL PIN ASSIGNMENTS

PIN NO.	NAME	FUNCTION	BLOCK
1	FR2	Focus Far - Tilt Down	3 Axis Actuator
2	FR2	Focus Near - Tilt Up	
3	TD	Tracking Out	
4	TR	Tracking In	
5	FR1	Focus Far - Tilt Up	
6	FD1	Focus Near - Tilt Down	
7	GND	-	Power Supply
8	GND	-	
9	VCC_LDB	System & DVDCD LD Power Supply (5 V)	
10	VCC_LDB	System & DVDCD LD Power Supply (5 V)	
11	GND	-	
12	VCC_LDB	BD LD Power Supply (8 V)	
13	VCC_LDB	BD LD Power Supply (8 V)	
14	GND	-	
15	GND	-	Monitor Signal
16	TEST_V	-	
17	LDEN	-	I/O Port
18	SEN_LDD	-	SIO
19	SCLK	-	
20	SDIO	-	
21	GND	-	GND
22	GND	-	
23	NC	Connectes to GND at servo PWB	I/O Port
24	MODEB	-	
25	MODEA	-	
26	GND_PD	OEIC GND	RF Signal
27	RF-	RF- (Differential Output)	
28	RF+	RF+ (Differential Output)	
29	GND_PD	OEIC GND	Servo Signal
30	VCC_PD	OEIC Power Supply	
31	G	Servo Signal G	
32	A	Servo Signal A	
33	C	Servo Signal C	
34	H	Servo Signal H	
35	F	Servo Signal F	
36	D	Servo Signal D	
37	B	Servo Signal B	
38	E	Servo Signal E	
39	VC_PD	OEIC Reference Voltage	Monitor Signal
40	THERMO	-	
41	GND	-	GND
42	SA_B+	SA Motor B+	SA Actuator
43	SA_B-	SA Motor B-	
44	SA_A+	SA Motor A+	
45	SA_A-	SA Motor A-	

# BLOCK DIAGRAM

