



DISHWASHER

SERVICE MANUAL

NOTE

BEFORE SERVICING THE UNIT, PLEASE READ THIS MANUAL CAREFULLY FOR SAFETY AND CORRECT SERVICES.

**MODEL : LDF6810(WW,BB,ST), LDF7810(WW,BB,ST), LDF7811(WW,BB,ST)
LDS5811(WW,BB,ST), LDF8812(WW,BB,ST)
LDF6810(WW,BB,ST) / 01, LDF7810(WW,BB,ST) / 01
LDF7811(WW,BB,ST) / 01, LDS5811(WW,BB,ST) / 01
LDF6810(WW,BB,ST) / 02, LDS5811(WW,BB,ST) / 02
LDF8812(WW,BB,ST) / 01**

CONTENTS

1. CAUTION.....	4
2. SPECIFICATIONS	5
3. WIRING DIAGRAM.....	6
4. FEATURES & TECHNICAL EXPLANATION	7
5. PARTS NAME	18
6. PROGRAM CHART	22
7. HOW TO DISASSEMBLE	26
8. TROUBLE SHOOTING METHODS.....	36
A. TROUBLE SHOOTING ACCORDING TO DISPLAYED ERROR MESSAGE.....	36
B. TROUBLE DIAGNOSES AND REPAIR BY SYMPTOM.....	38
9. INSTALLATION INSTRUCTION	41
10. EXPLODED VIEW	49
▶ APPENDIX	64

CAUTION !

- DISCONNECT POWER CORD BEFORE SERVICING
- RECONNECT ALL GROUNDING DEVICES

IMPORTANT SAFETY NOTICE !

This service information is intended for individuals possessing adequate backgrounds of electrical, electronic and mechanical experience.

Any attempt to repair this appliance may result in personal injury and property damage.

The manufacturer or seller can not be responsible for the interpretation of this information, nor can it assume any liability in connection with its use.

2. SPECIFICATION

ITEM	SPECIFICATION
Rated Voltage / Frequency	AC 120V/60Hz
Installation	Built-In
Place Settings	16
Product Dimension(in)	23 7/8" x 25" x 33 7/8"
Product Weight(lbs)	7811, 7810, 8812 series : 115lbs, 5811/6810 series : 110lbs
Door Color	White, Black, Stainless
Tub Material	Stainless Steel
Control	Electronic
Rated Power(Watt)	1,350
Heater Power(Watt)	1,200
Programs	7811, 7810, 5811, 8812 series : 6, 6810 series : 5
Upper Rack Position	7811, 7810, 8812 series : Adjustable, 6810 series : manual
Lower Rack	50% Fold down
Water Consumption (ℓ)	7811,7810 , 6810, 5811 series : 21-30 (Normal) 8812, 7811/01, 7810/01, 6810/01, 5811/01 series : 10-26 (Normal)
Power Consumption(kWh/year)	7811/ 7810/ 6810 / 5811 series : 352-370 8812, 7811/01, 7810/01, 6810/01, 5811/01 series : 285-310
Operating Time (min)	101-135 (Normal)
Fan Dry System	Yes
Delay Start Function	Yes
Auto-Off Power Switch	Yes
Process Monitor	Yes
Wash Level	5
Racks	Nylon Coating
Operating Water Pressure (Bar)	20-120 (140-830kPa)

3. WIRING DIAGRAM

1. 7811 / 7810 / 6810 serie

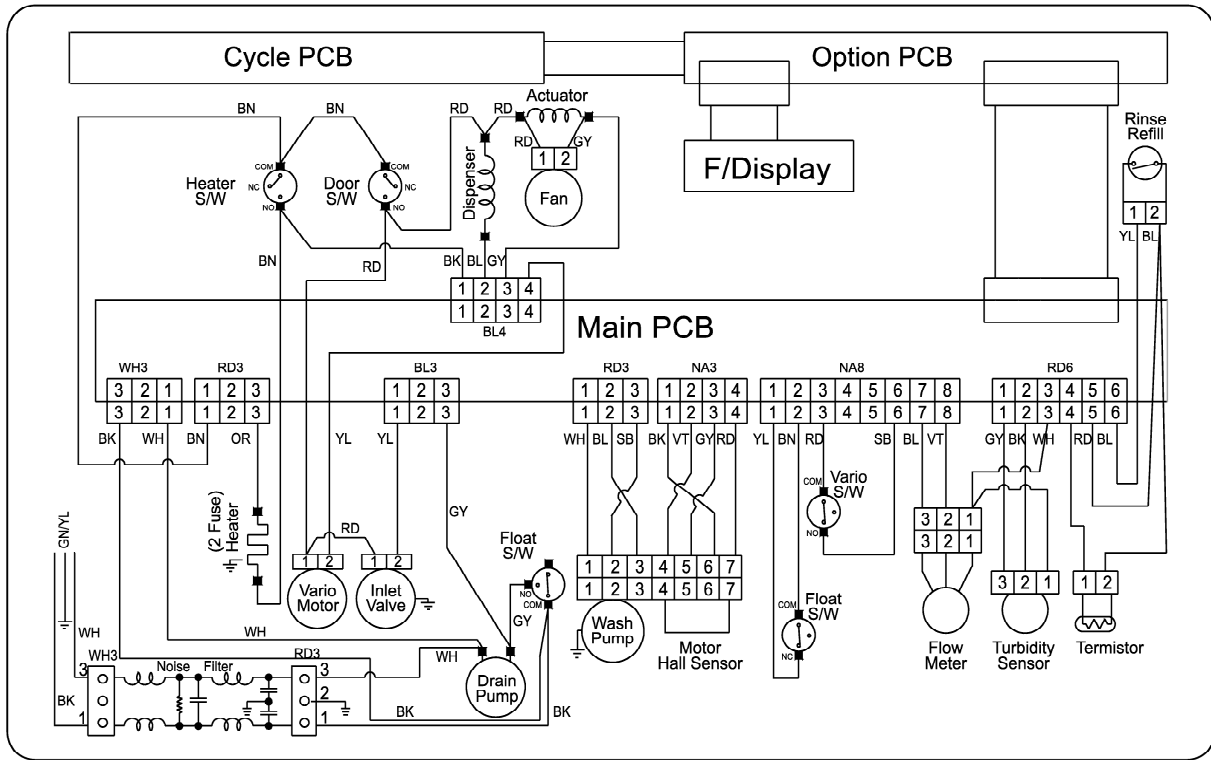

2. 8812 serie

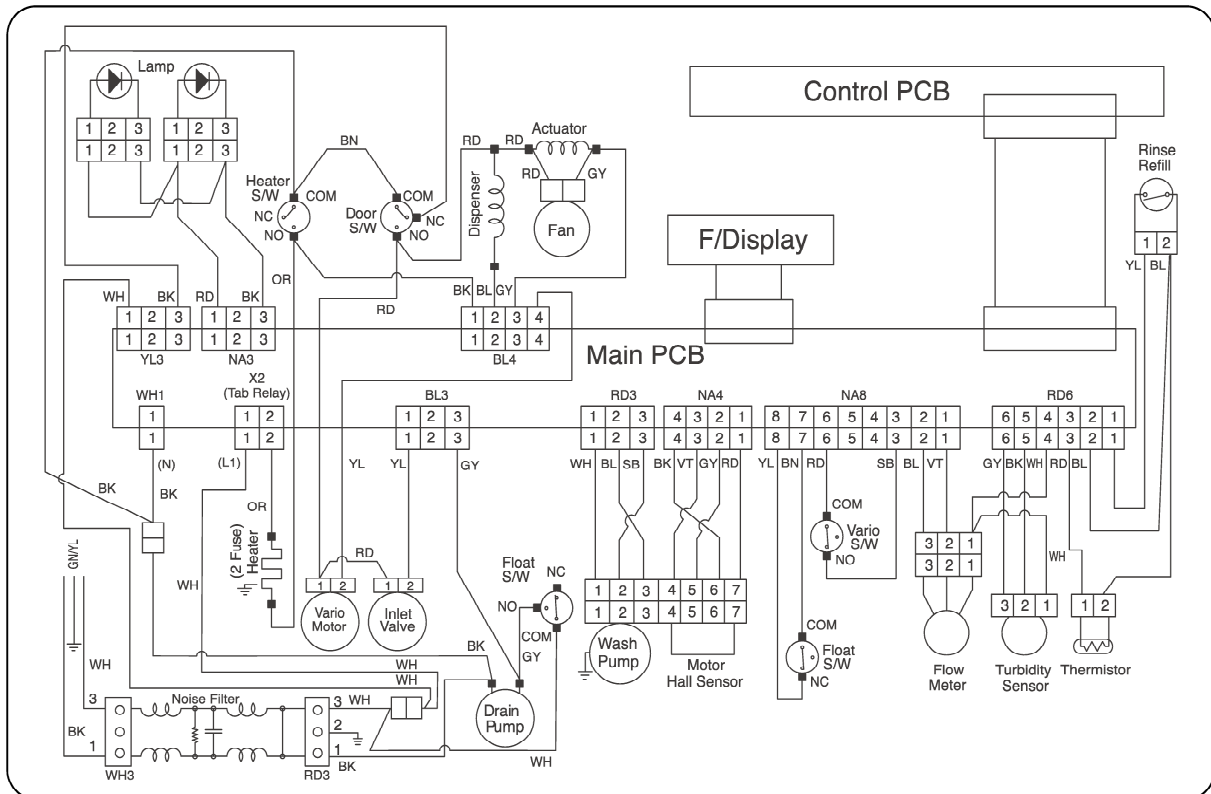

4. FEATURES & TECHNICAL EXPLANATION

4-1. Product Features

■ Ultra Big Capacity

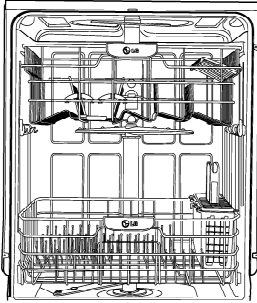

If you raise the Upper Rack, you can load large dishes in the Lower Rack. (Max. 14 in.)

The tall tub provides large dishes loading as well as large capacity.

LG dishwashers let you load oversized items in the Lower and Upper Rack.

■ Slim Direct Motor™

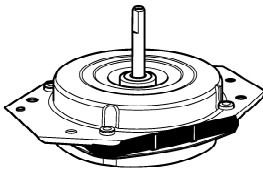

Newly introduced Slim Direct Inverter motor is inverter-controlled. Speed is controlled based on program selection. It also offers high energy efficiency to minimize energy loss.

■ Hybrid Drying System

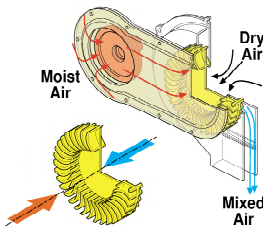

This is one of the best performance solutions for drying dishes because it minimizes venting humid air to the outside of the dishwasher. In addition, this system ensures better drying results compared to the condensing drying system.

■ Vario Spray System

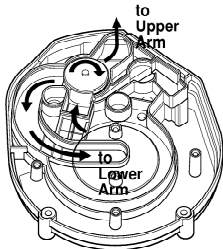

Because of alternating water spray between the Upper and Lower Rack, the water pressure allows superior performance and reduced consumption of water and electricity.

■ Self Cleaning Filter

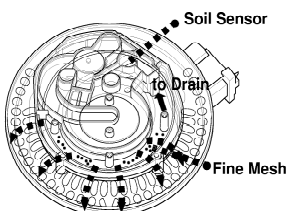

For best wash results, the self-cleaning filter system continuously cleans the water as it circulates. Your LG dishwasher has a self-cleaning filter that grinds food into small particles before it goes down the drain.

4-2. Display Panel

4-2-1. LDF 7811/7810 Series

- Control panel may vary on some models.

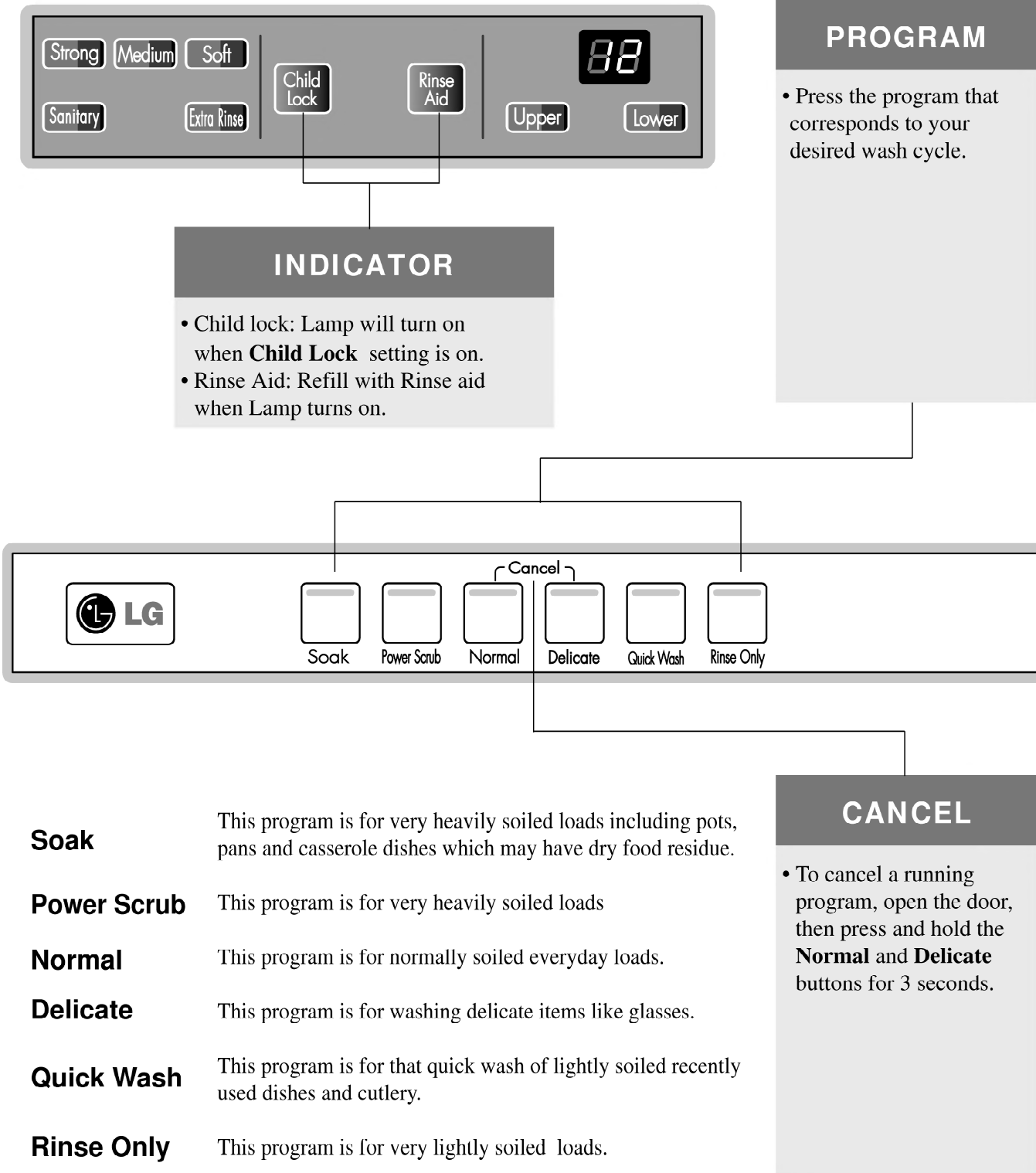

Soak

This program is for very heavily soiled loads including pots, pans and casserole dishes which may have dry food residue.

Power Scrub

This program is for very heavily soiled loads

Normal

This program is for normally soiled everyday loads.

Delicate

This program is for washing delicate items like glasses.

Quick Wash

This program is for that quick wash of lightly soiled recently used dishes and cutlery.

Rinse Only

This program is for very lightly soiled loads.

CANCEL

- To cancel a running program, open the door, then press and hold the **Normal** and **Delicate** buttons for 3 seconds.

SPRAY (INTENSITY)

- Repeated pressing of the Spray button will select **Strong**, **Medium** or **Soft**.

DELAY START

- If you want to delay the start of a selected program, press the **Delay Start** button.
- Each press of **Delay Start** will delay the start of the cycle by one hour.
- The delay start time can be adjusted from 1 to 24 hours in one-hour increment.

POWER

- For operating, press this button first for power on.
- After operating, the power automatically switches off for safety and economy.
- In case of an unusual Power surge or disturbance, the power may be automatically turned off for safety.

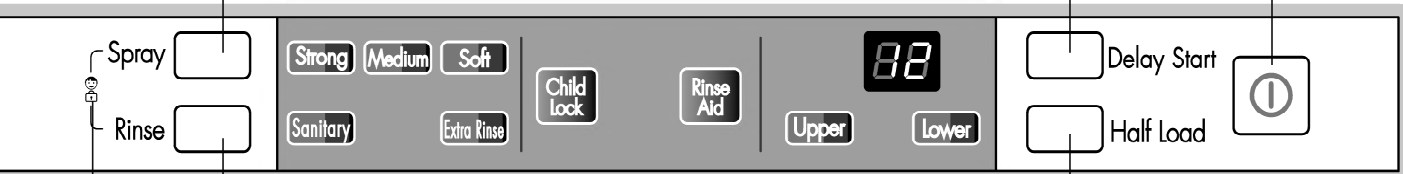

CHILD LOCK

- Lock the control buttons to prevent the settings from being changed.
- To lock/unlock, press **Spray** and **Rinse** buttons simultaneously for 3 seconds with door open.

SANITARY/ EXTRA RINSE

- Repeated pressing of the Rinse button will select **Sanitary**, **Extra Rinse** or both.
- If you select the **Sanitary** function, the temperature of Heating Rinse can reach 161°F (72°C).
- When you select **Extra Rinse**, an additional rinse cycle is added.

HALF LOAD

- In case of a small load, use the upper or lower rack only to save energy.
- Each press of the **Half Load** button cycles between upper rack only and lower rack only.
- If you don't press **Half Load**, the dishwasher runs normally, i.e. operation of upper and lower spray arm alternating periodically.

4-2-2. LDF 5811 Series

SPRAY (INTENSITY)

- Repeated pressing of the Spray button will select **Strong, Medium** or **Soft**.

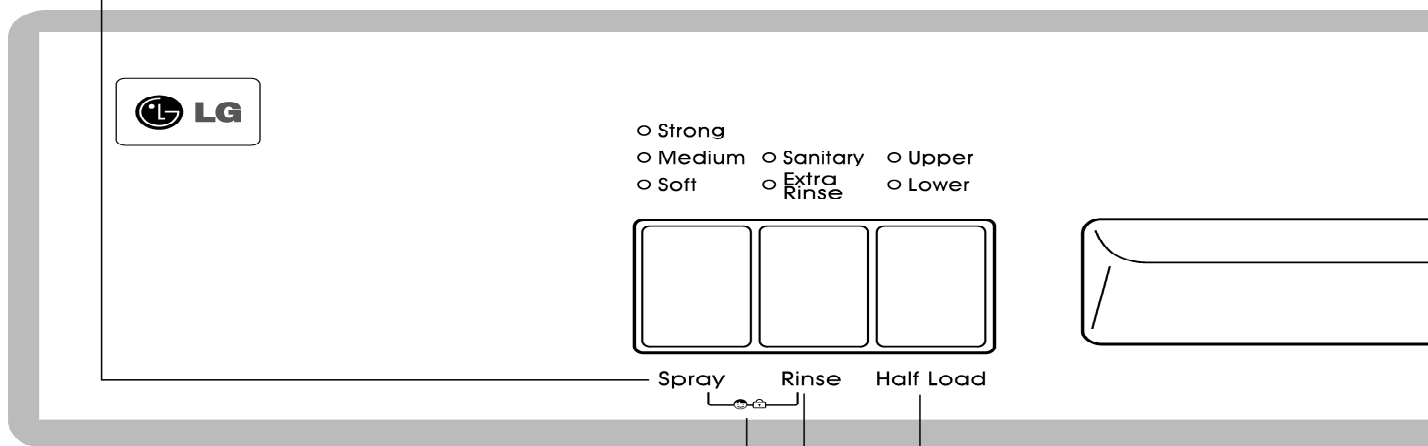

CHILD LOCK

- Lock the control buttons to prevent the settings from being changed.
- To lock/unlock, press **Spray** and **Rinse** buttons simultaneously for 3 seconds.

SANITARY/ EXTRA RINSE

- Repeated pressing of the Rinse button will select **Sanitary, Extra Rinse** or both.
- If you select the **Sanitary** function, the temperature of Heating Rinse can reach 161°F (72°C).
- When you select **Extra Rinse**, an additional rinse cycle is added.

HALF LOAD

- In case of a small load, use the upper or lower rack only to save energy.
- Each press of the **Half Load** button cycles between upper rack only and lower rack only.
- If you don't press **Half Load**, the dishwasher runs normally, i.e. operation of upper and lower spray arm alternating periodically.

INDICATOR

- Child lock: Lamp will turn on when **Child Lock** setting is on.
- Rinse Aid: Refill with Rinse aid when Lamp turns on.

PROCESSING INDICATOR

- Current program phase is indicated.

TIME LEFT

- Before starting, the display window shows the running time of the selected program.
- After starting, the display window shows the remaining time.
- If the dishwasher has a trouble, the trouble type is displayed.

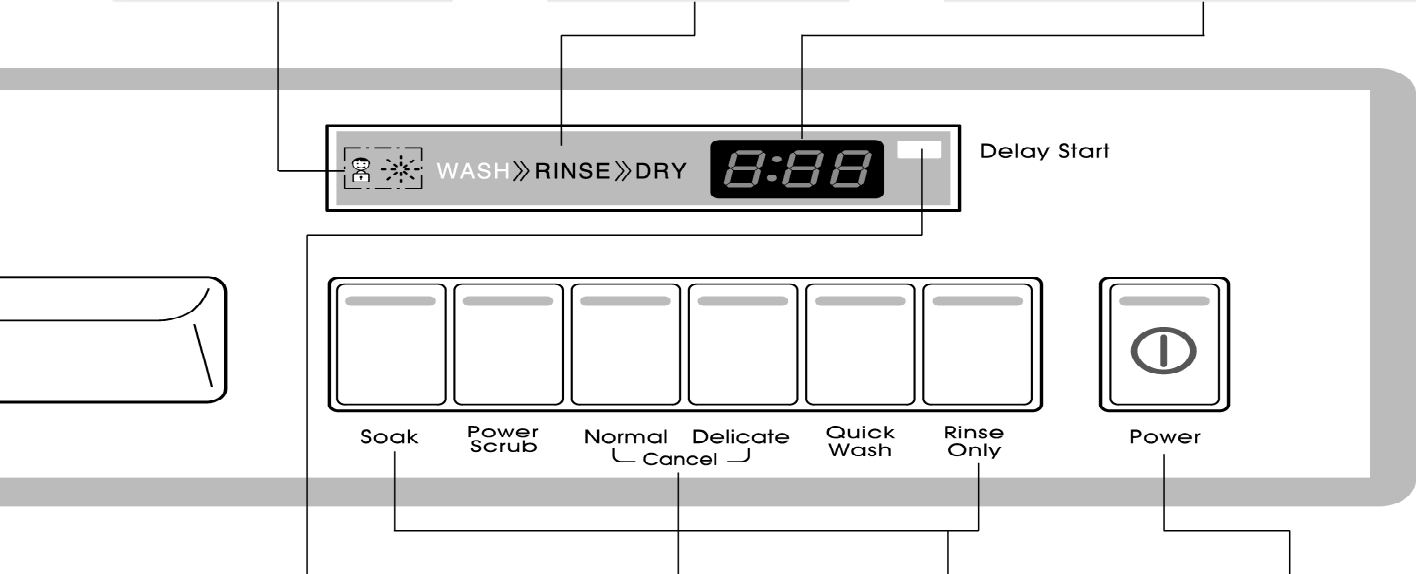

DELAY START

- If you want to delay the start of a selected program, press the **Delay Start** button.
- Each press of **Delay Start** will delay the start of the cycle by one hour.
- The delay start time can be adjusted from 1 to 12 hours in one-hour increment.

CANCEL

- To cancel a running program, press and hold the **Normal** and **Delicate** buttons for 3 seconds.

PROGRAM

- Press the program that corresponds to your desired wash cycle.

POWER

- For operating, press this button first for power on.
- After operating, the power automatically switches off for safety and economy.
- In case of an unusual Power surge or disturbance, the power may be automatically turned off for safety.

4-2-3. LDF 6810 Series

- Control panel may vary on some models.

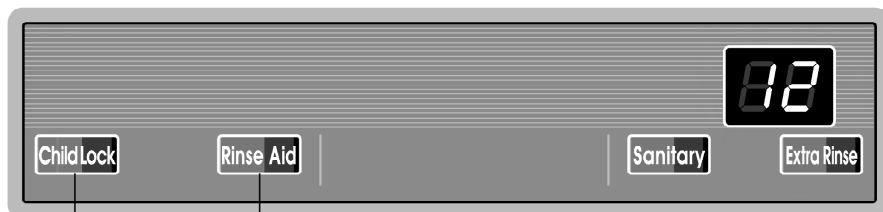

INDICATOR

- Child lock: Lamp will turn on when **Child Lock** setting is on.
- Rinse Aid: Refill with Rinse aid when Lamp turns on.

PROGRAM

- Press the program that corresponds to your desired wash cycle.

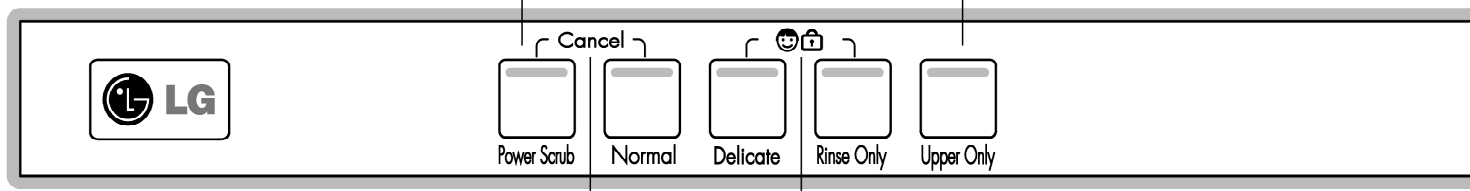

- Power Scrub** This program is for very heavily soiled loads
- Normal** This program is for normally soiled everyday loads.
- Delicate** This program is for washing delicate items like glasses.
- Rinse Only** This program is for very lightly soiled loads.
- Upper Only** This program is to wash some items loaded on the upper rack.

CANCEL

- To cancel a running program, open the door, then press and hold the **Power Scrub** and **Normal** buttons for 3 seconds.

DELAY START

- If you want to delay the start of a selected program, press the **Delay Start** button.
- Each press of **Delay Start** will delay the start of the cycle by one hour.
- The delay start time can be adjusted from 1 to 12 hours in one-hour increment.

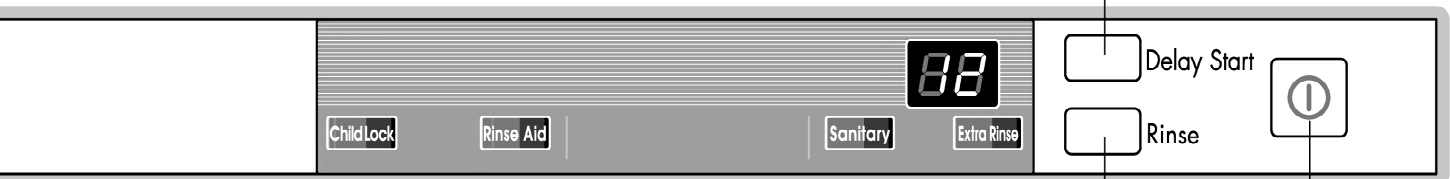

CHILD LOCK

- Lock the control buttons to prevent the settings from being changed.
- To lock/unlock, press **Delicate** and **Rinse Only** buttons simultaneously for 3 seconds with door open.

SANITARY/ EXTRA RINSE

- Repeated pressing of the Rinse button will select **Sanitary, Extra Rinse** or both.
- If you select the **Sanitary** function, the temperature of Heating Rinse can reach 161°F (72°C).
- When you select **Extra Rinse**, an additional rinse cycle is added.

POWER

- For operating, press this button first for power on.
- After operating, the power automatically switches off for safety and economy.
- In case of an unusual Power surge or disturbance, the power may be automatically turned off for safety.

4-2-4. LDF 8812 Series

- Control panel may vary on some models.



INDICATOR

- Child Lock(🔒): Lamp will turn on when **Child Lock** setting is on.
- Rinse Aid(*): Refill with rinse aid when Lamp turns on.

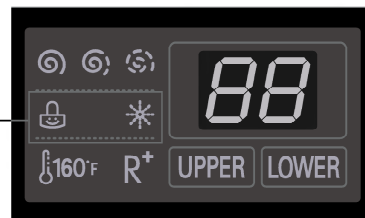

PROGRAM

- Press the program that corresponds to your desired wash cycle.

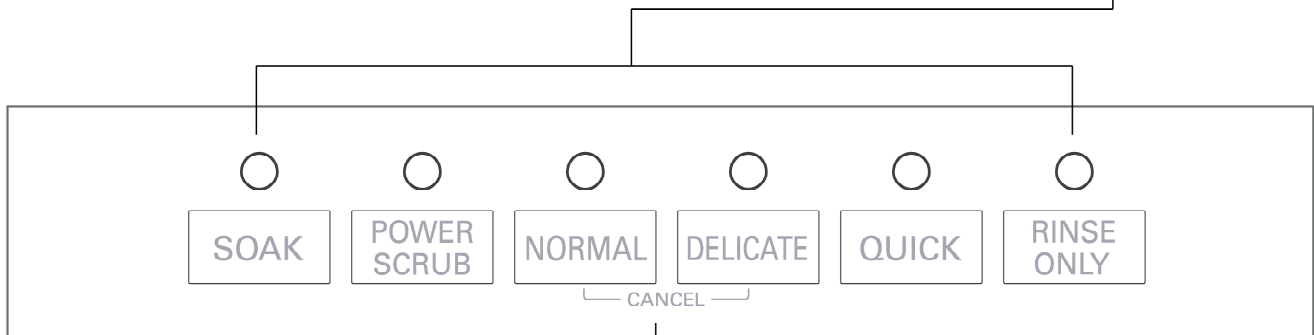

Soak

This program is for very heavily soiled loads including pots, pans, and casserole dishes, which may have dry food residue.

Power Scrub

This program is for very heavily soiled loads

Normal

This program is for normally soiled, everyday loads.

Delicate

This program is for washing delicate items like glasses.

Quick

This program is for that quick wash of lightly soiled, recently used dishes and cutlery.

Rinse Only

This program is for very lightly soiled loads.

CANCEL

- To cancel a running program, open the door, then press and hold the **Normal** and **Delicate** buttons for 3 seconds.
- The drain pump will be activated and the cycle will be canceled.

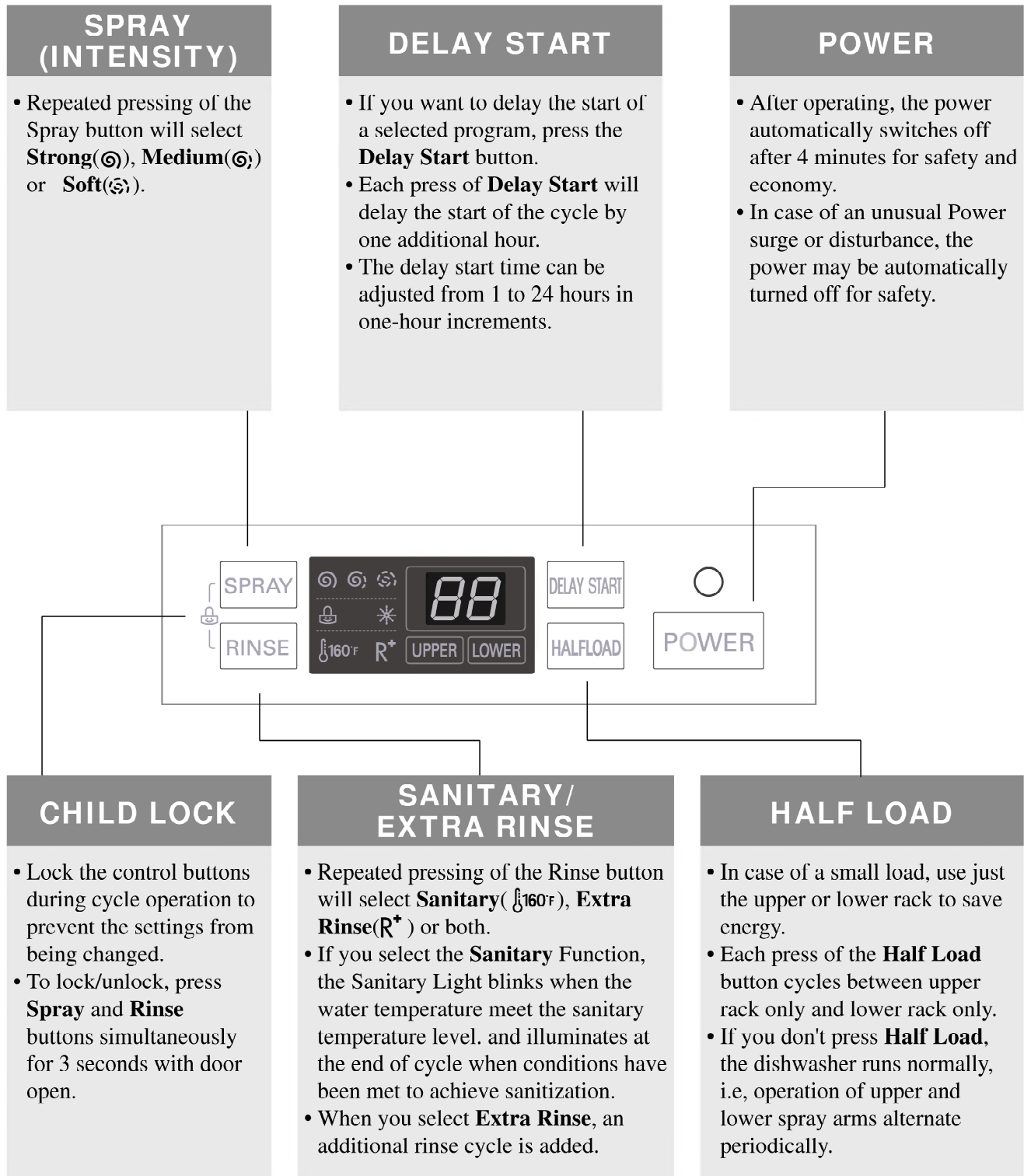

4-3. TEST MODE

4-3-1. LDF 7811/7810/8812 LDS 5811 Series

CHECK PROGRAM

BUTTON	The number of pushing button	Top Display	Front Display	Load and Checking points		Door open/closed
Rinse + Time Delay + POWER S/W	1 TIME	3H/U2	n : 3H/U:02	All LEDs are lighting		Both
Soak	1 TIME	11	1 : 11	All LEDs are lighting		Both
Power Scrub	1 TIME	22	2 : 22	All LEDs are lighting		Both
Normal	1 TIME	33	3 : 33	All LEDs are lighting		Both
Delicate	1 TIME	44	4 : 44	All LEDs are lighting		Both
Quick Wash	1 TIME	55	5 : 55	All LEDs are lighting		Both
Rinse Only	1 TIME	66	6 : 66	All LEDs are lighting		Both
Spray	1 TIME	77	7 : 77	Strong/Medium/Soft		Both
Rinse	1 TIME	88	8 : 88	Sanitary-Extra Rinse		Both
Half Load	1 TIME	99	9 : 99	Upper-Lower		Both
Time Delay	1 TIME	31	^① Soil Level	Soil Sensor	Delay Start	Both
	2 TIME	32	n : 02	Wash Pump	Child Lock + Rinse Aid	Closed
	3 TIME	33	n : 03	Drain Pump	Wash	Closed
	4 TIME	34	^② Frequency	Inlet Valve	Rinse	Both
	5 TIME	35	n : 05	Dispenser	Dry	Closed
	6 TIME	36	n : 06	Heater (for 10 sec)	Wash-Rinse-Dry	Closed
	7 TIME	37	n : 07	Fan	Strong-Soft	Closed
	8 TIME	38	n : 08		Sanitary-Extra	
	9 TIME	39	Temp. (°C)	Thermistor	Upper-Lower	Both
	10 TIME	3A	n : 0A	Lower Nozzle (VARIO)	Soak-Normal	Closed
	11 TIME	3b	n : 0b	Upper Nozzle (VARIO)	Delicate-Rinse Only	Closed
	12 TIME	3c	n : 0c	Wash-Drain-Water Supply	Rinse Aid	Closed
	13 TIME			Auto-Off		Closed

① Normal Water Level : 315

② Pure Water : more than 229

※ Supply water before operating the Test Mode.

4-3-2. LDF 6810 Series

CHECK PROGRAM

BUTTON	The number of pushing button	Top Display	Load and Checking points		Door open/closed
Upper Only + Time Delay + POWER	1 TIME	3H/U2	All LEDs are lighting		Both
Power Scrub	1 TIME	11	All LEDs are lighting		Both
Normal	1 TIME	22	All LEDs are lighting		Both
Delicate	1 TIME	33	All LEDs are lighting		Both
Rinse Only	1 TIME	44	All LEDs are lighting		Both
Upper Only	1 TIME	55	All LEDs are lighting		Both
					Both
Rinse	1 TIME	66	All LEDs are lighting		Both
					Both
Time Delay	1 TIME	31			Both
	2 TIME	32	Wash Pump		Closed
	3 TIME	33	Drain Pump		Both
	4 TIME	34	Inlet Valve		Closed
	5 TIME	35	Dispenser		Closed
	6 TIME	36	Heater (for 10 sec)		Closed
	7 TIME	37	Fan		Closed
	8 TIME	38		Child Lock + Rinse Aid	
	9 TIME	39	Thermistor	Sanitary-Extra	Both
	10 TIME	3A	Lower Nozzle (VARIO)	Power Scrub + Normal + Delicate	Closed
	11 TIME	3b	Upper Nozzle (VARIO)	Rinse Only + Upper Only	Closed
	12 TIME	3c	Wash-Drain-Water Supply	Rinse Aid	Closed
	13 TIME		Auto-Off		Closed

① Normal Water Level : 295

5. PARTS NAME

5-1. LDF 7811/7810 Series

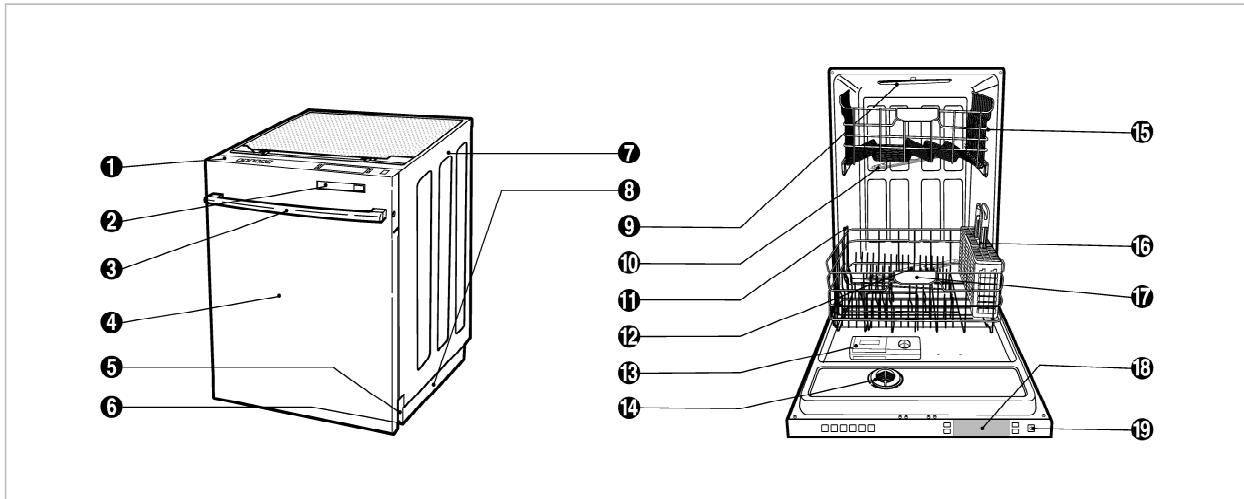

- | | |
|-------------------|------------------------------------|
| ❶ Control Panel | ❶❶ Removable Tines |
| ❷ Front Display | ❶❷ Lower Spray Arm |
| ❸ Door Handle | ❶❸ Detergent & Rinse Aid Dispenser |
| ❹ Front Cover | ❶❹ Vapor Vent Cover |
| ❺ Lower Cover | ❶❺ Upper Rack |
| ❻ Leveling Foot | ❶❻ Cutlery Basket |
| ❼ Side Cabinet | ❶❼ Lower Rack |
| ❽ Base | ❶❽ Top Display |
| ❾ Top Spray Arm | ❶❾ Power Button |
| ❿ Upper Spray Arm | |

Accessories

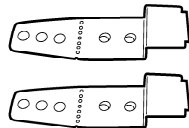

INSTALL BRACKET



WOOD SCREW

※ The appearance and specifications may be varied without notice according to localities.

5-2. LDF 5811 Series

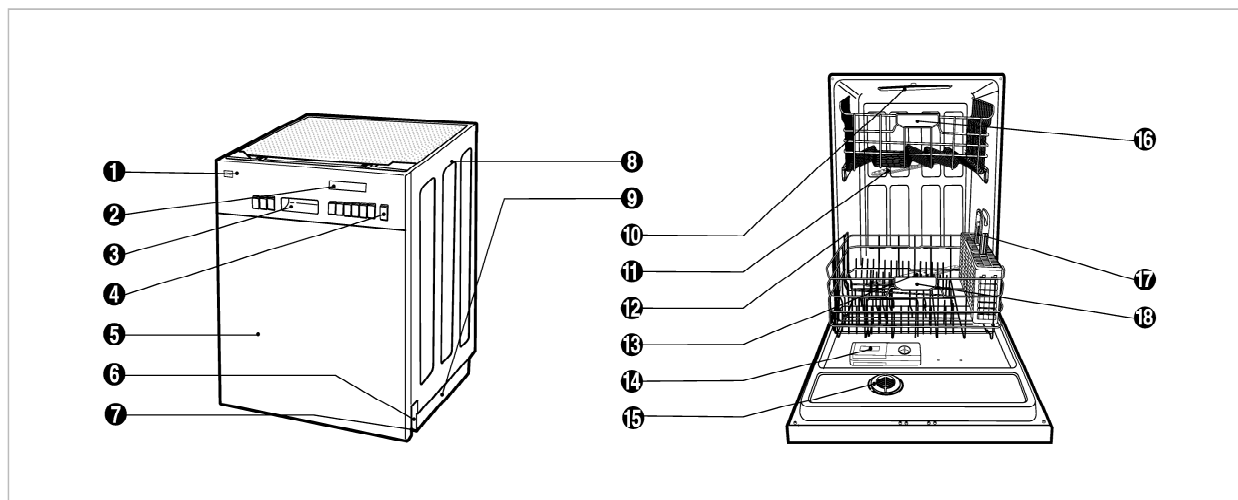

- ❶ Control Panel
- ❷ Front Display
- ❸ Door Handle
- ❹ Power Button
- ❺ Front Cover
- ❻ Lower Cover
- ❼ Leveling Foot
- ❽ Side Cabinet
- ❾ Base

- ❿ Top Spray Arm
- ⓫ Upper Spray Arm
- ⓬ Removable Tines
- ⓭ Lower Spray Arm
- ⓮ Detergent & Rinse Aid Dispenser
- ⓯ Vapor Vent Cover
- ⓰ Upper Rack
- ⓱ Cutlery Basket
- ⓲ Lower Rack

Accessories

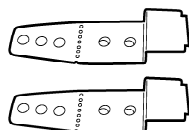

INSTALL BRACKET



WOOD SCREW

※ The appearance and specifications may be varied without notice according to localities.

5-3. LDF 6810 Series

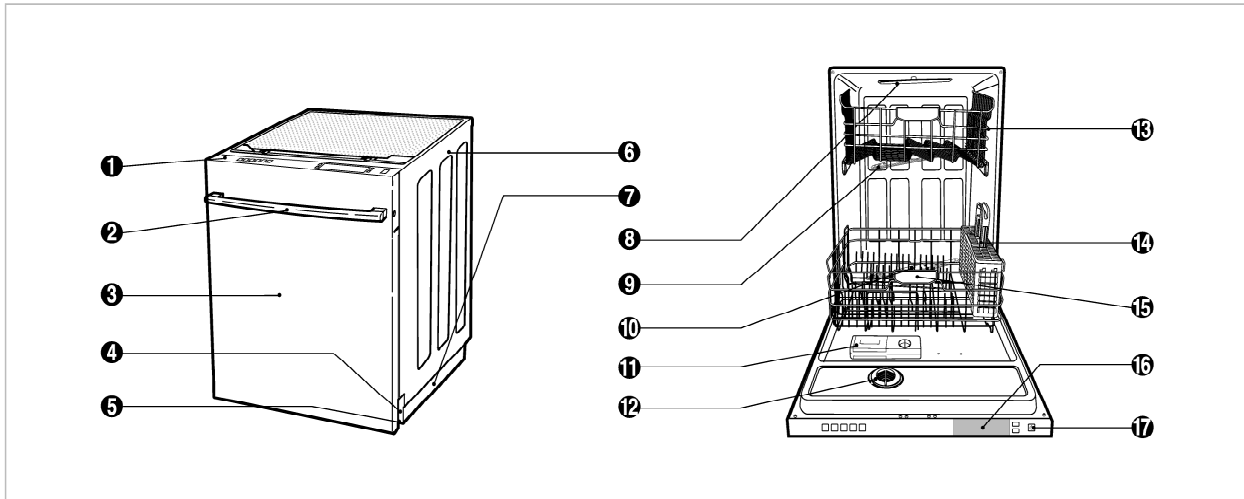

- | | |
|-------------------|-----------------------------------|
| ❶ Control Panel | ❿ Lower Spray Arm |
| ❷ Door Handle | ⓫ Detergent & Rinse Aid Dispenser |
| ❸ Front Cover | ⓬ Vapor Vent Cover |
| ❹ Lower Cover | ⓭ Upper Rack |
| ❺ Leveling Foot | ⓮ Cutlery Basket |
| ❻ Side Cabinet | ⓯ Lower Rack |
| ❼ Base | ⓰ Top Display |
| ❽ Top Spray Arm | ⓱ Power Button |
| ❾ Upper Spray Arm | |

Accessories

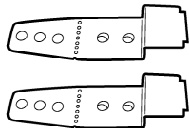

INSTALL BRACKET



WOOD SCREW

※ The appearance and specifications may be varied without notice according to localities.

5-3. LDF 8812 Series

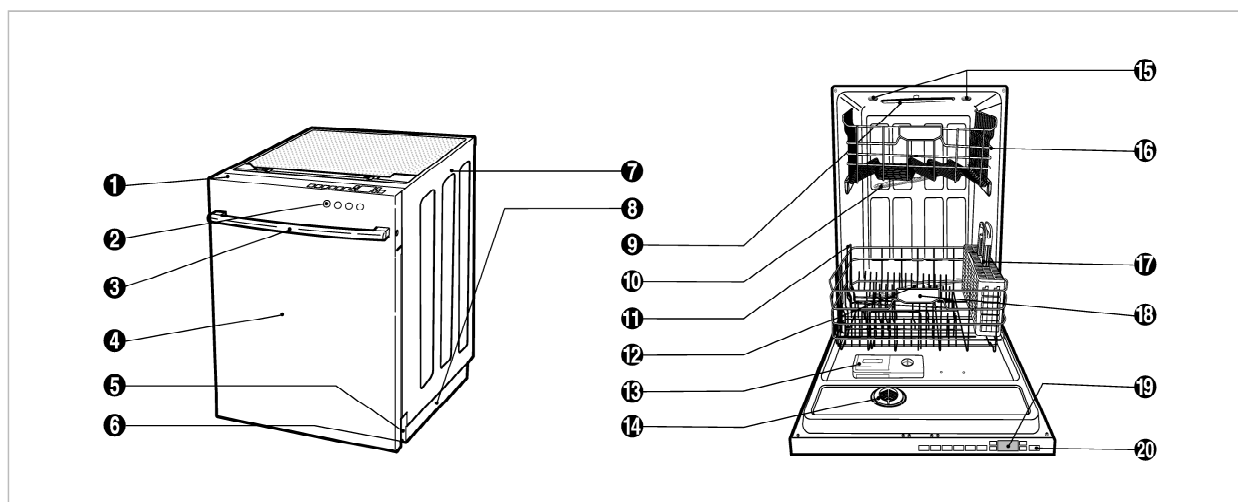

- | | |
|--|------------------------------------|
| ❶ Control Panel | ❶❶ Removable Tines |
| ❷ Front Display (Signalight™) | ❶❷ Lower Spray Arm |
| ❸ Door Handle | ❶❸ Detergent & Rinse Aid Dispenser |
| ❹ Front Cover | ❶❹ Vapor Vent Cover |
| ❺ Lower Cover | ❶❺ Tub Lamp (IllumiTub™) |
| ❻ Leveling Foot | ❶❻ Upper Rack |
| ❼ Side Cabinet | ❶❼ Cutlery Basket |
| ❽ Base | ❶❽ Lower Rack |
| ❾ Top Spray Arm | ❶❾ Top Display |
| ❿ Upper Spray Arm | ❶❿ Power Button |

* **IllumiTub™** comes on when the door is opened. It goes off when the door is closed.

Accessories

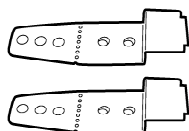

INSTALL BRACKET



WOOD SCREW

※ The appearance and specifications may be varied without notice according to localities.

7. HOW TO DISASSEMBLE

BEFORE DISASSEMBLING THE DISHWASHER ;

- 1) Remove the cord from electric outlet to avoid electric shock.
- 2) Close the Water Tap (faucet).
- 3) Remove all dishes and items in the dishwasher.
- 4) Remove the Lower Rack and the Upper Rack.
- 5) Remove the inlet hose and drain hose connection to avoid the hose damages.
- 6) Prepare some towels to avoid floor wet by the water left in the dishwasher.

7-1. FULL DISASSEMBLE

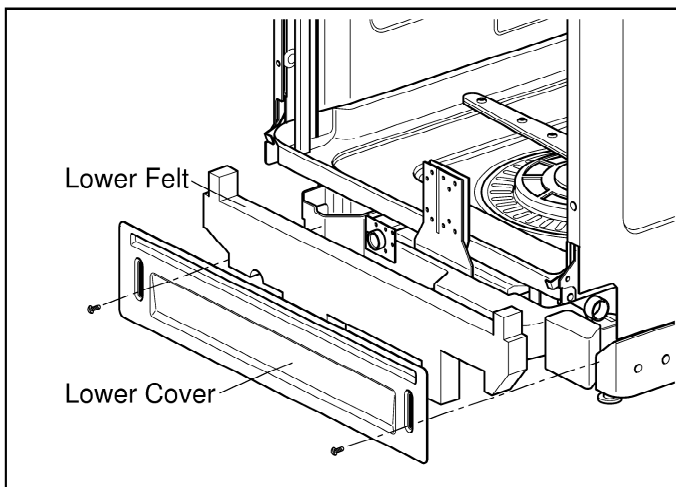

1. Lower Cover and Lower Felt

- 1) Remove the front 2 screws.
- 2) Pull the Felt.
- 3) Remove the Inlet Hose and Power Supply Cable.

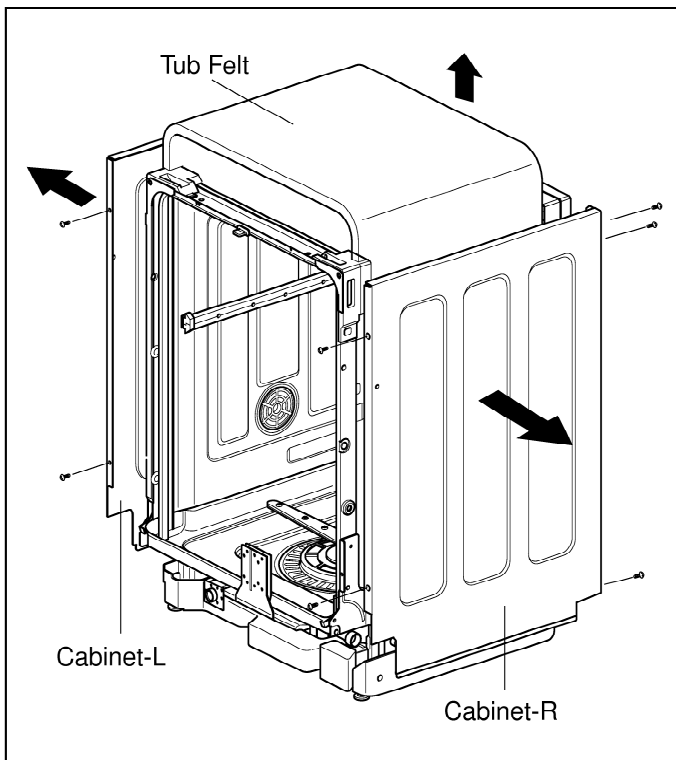

2. Cabinet and Tub Felt

- 1) **Cabinet-R**
 - ① Remove front 2 screws.
 - ② Remove rear 3 screws.
- 2) **Cabinet-L**
 - ① Remove front 2 screws.
 - ② Remove rear 3 screws.
- 3) **Tub Felt**
 - ① Pull the Tub Felt.

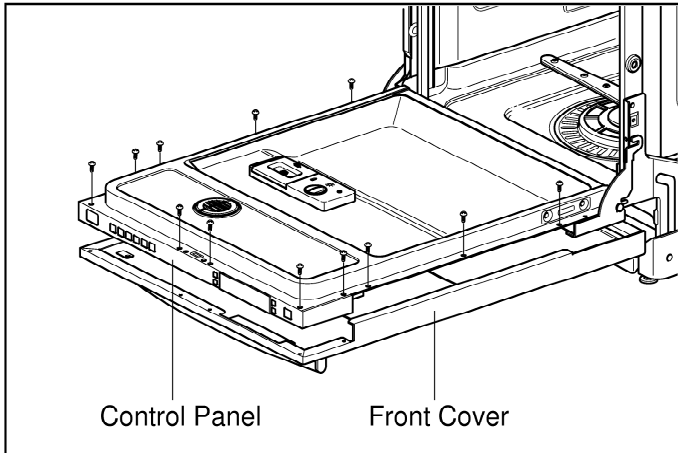

3-1. Door Assembly (LDF 6810/7811/7810/8812 Series)

1) Front Cover

- ① Open the door.
- ② Remove 12 screws(stainless).

2) Control Panel Assembly

- ① Remove 2 screws(Stainless).
- ② Remove the wire connections.

Be sure the wiring should not be changed in reassembling

- ③ Remove the Latch assembly.
- ④ Remove the Front Display.
- ⑤ Remove 8 screws for Controller.

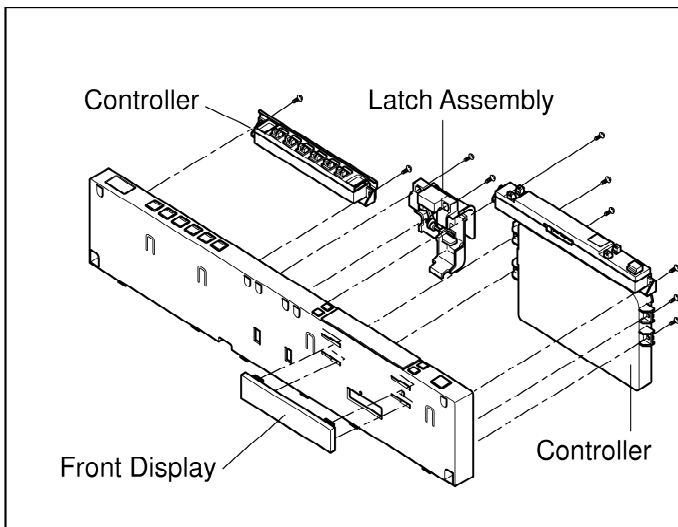
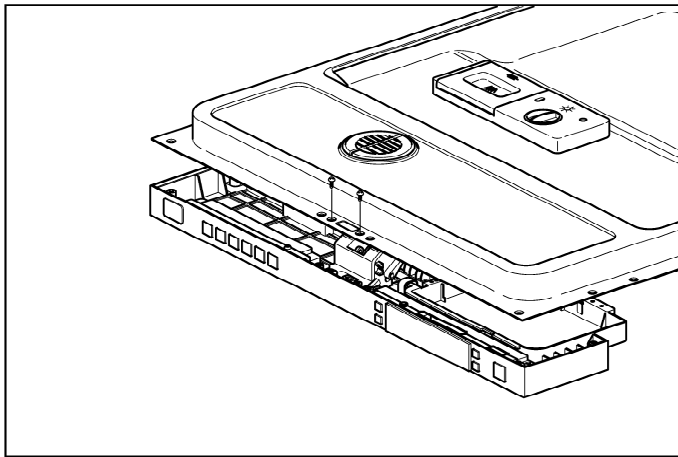

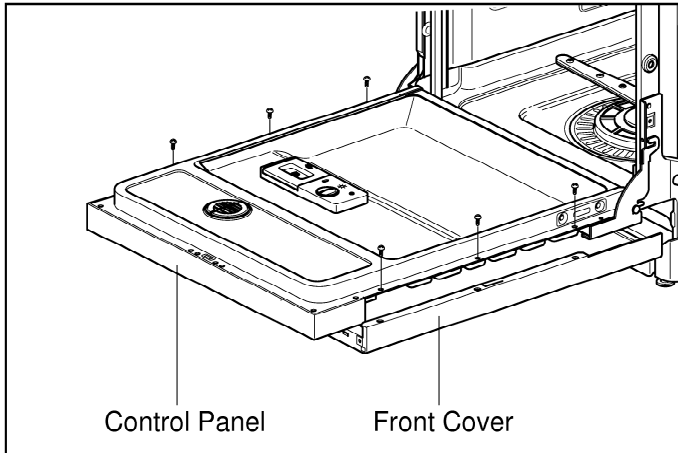

3-2. Door Assembly (LDF 5811 Series)

1) Front Cover

- ① Open the door.
- ② Remove 6 screws(Stainless).

2) Control Panel Assembly

- ① Remove 8 screws(Stainless).
- ② Remove the wire connections.

Be sure the wiring should not be changed in reassembling

- ③ Remove the Latch assembly.
- ④ Remove 8 screws for Controller.

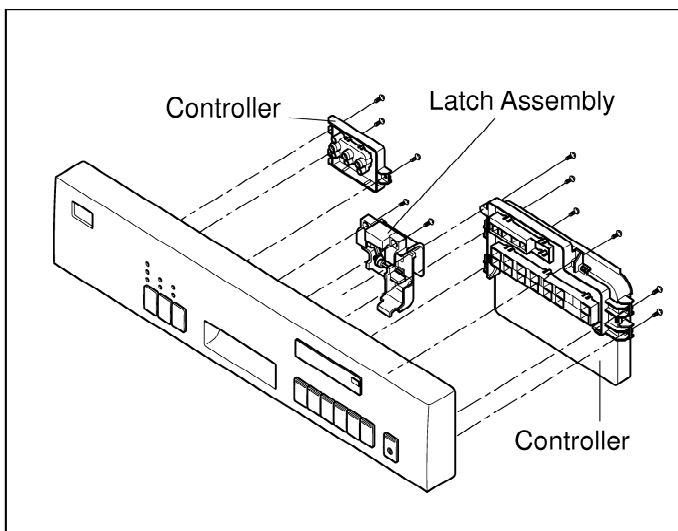
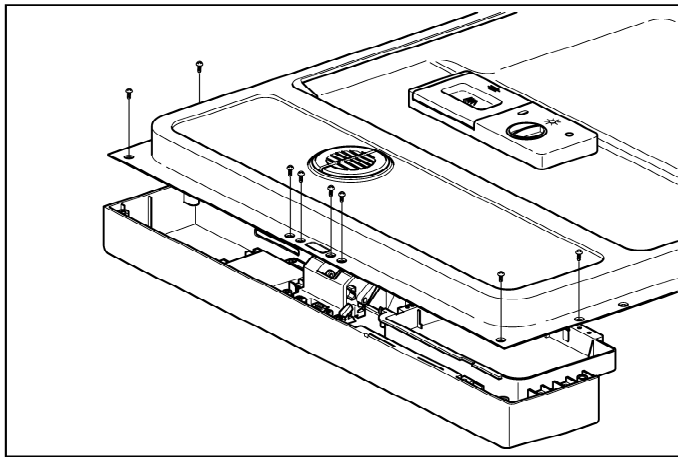

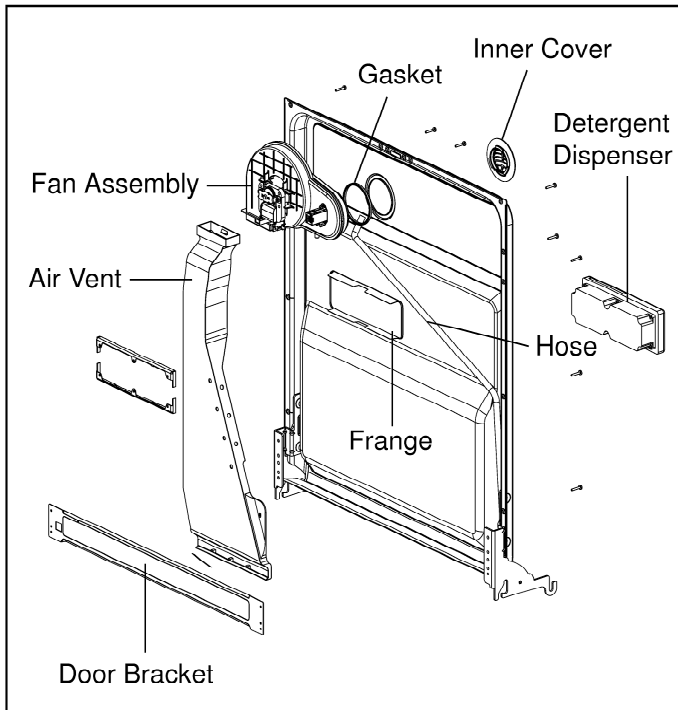

3) Fan Assembly

- ① Open the Door.
- ② Remove 4 screws and a earth screw for Door Bracket.
- ③ Remove the wire connector.
- ④ Remove the Air Duct.
- ⑤ Remove Hose with Clamp.(Some Moels)
- ⑥ Turn the Inner Cover counterclockwise.

4) Detergent Dispenser

- ① Close the door
- ② Remove the wire connections.
- ③ Remove 6 screws with brackets.
- ④ Push the Detergent slowly pulling up the the Frange by Standard Screwdriver.

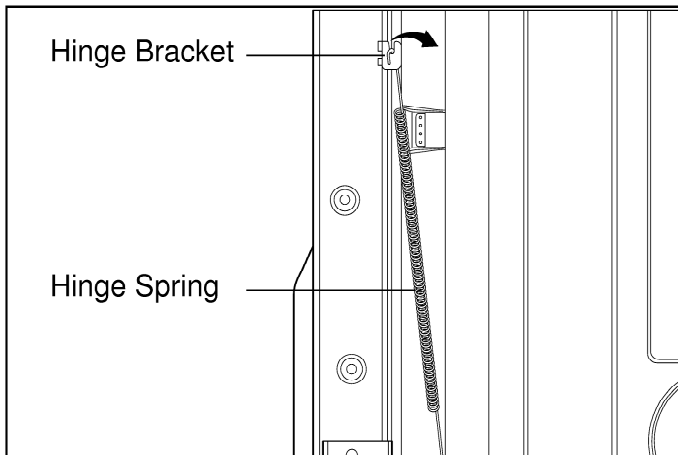

5) Door Spring (Right & Left)

- ① Push the Spring upwards and take it off from the Hinge Bracket.
- Be careful not to be injured by the sharp edge of Tub.
- ② Take off the Hinge Link from the Hinge.

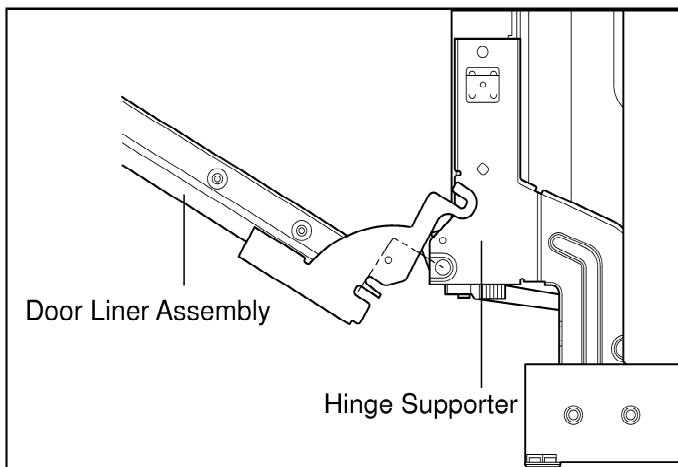

6) Door Liner

- ① Open the door.
- ② Pull the Door Liner and take it off from the Hinge Supporter.

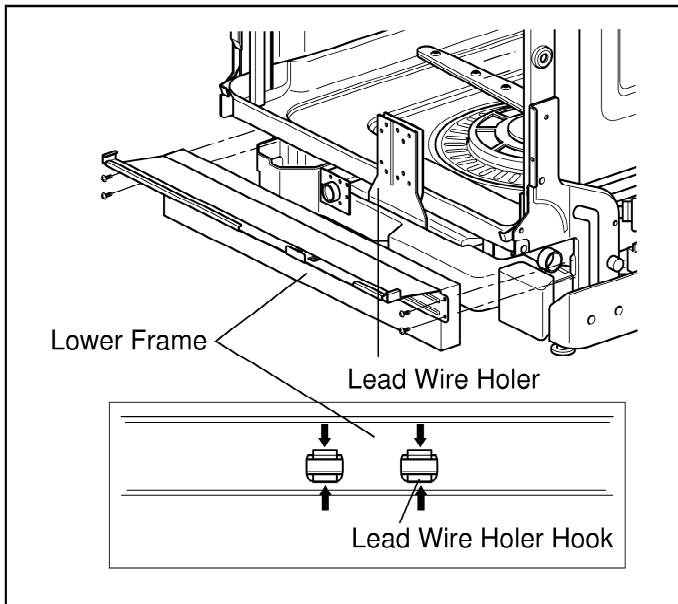

4. Lower Frame

- 1) Press the holder hook as shown in figure.
- 2) Remove 4 screws.

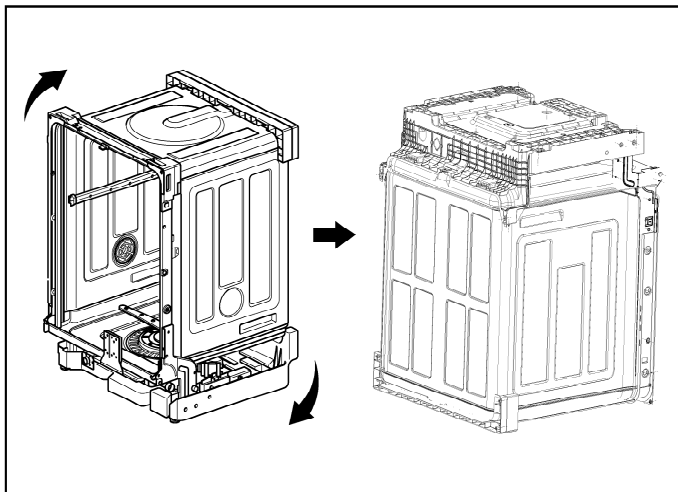

5. Put the Dishwasher upside down.

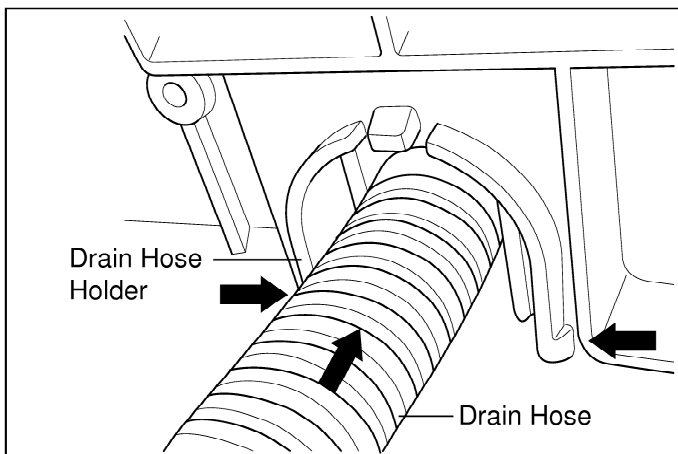

6. Drain Hose Holder

- 1) Press the holder hook as shown in figure.
- 2) Pull the Drain Hose and remove the Drain Hose Holder.

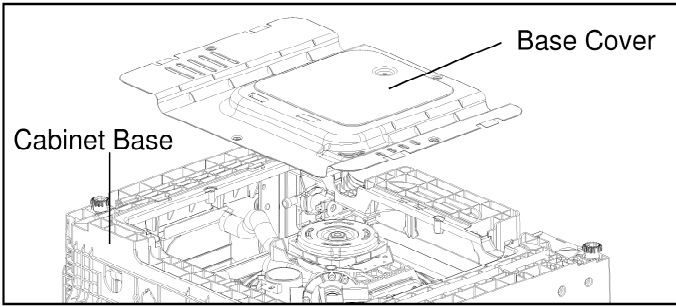

7. Base Cover

- 1) Remove 2 screws.
- 2) Pull the Base Cover out.

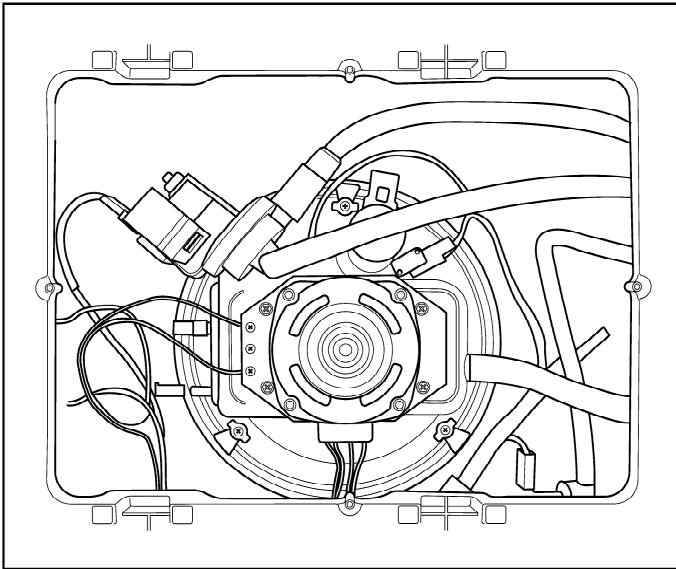

8. Harness & Hose Assembly

- 1) Remove the wiring connections.
- 2) Remove the Hose connections from Sump Assembly.

You can see the information of Wiring Diagram at the back of Lower Cover.

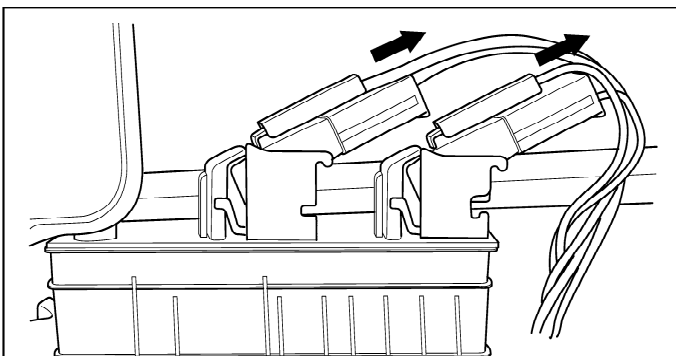
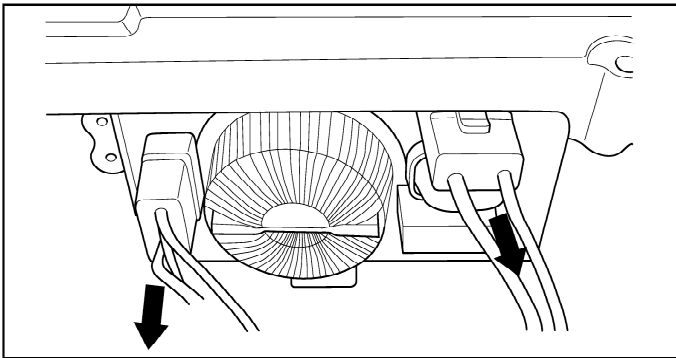

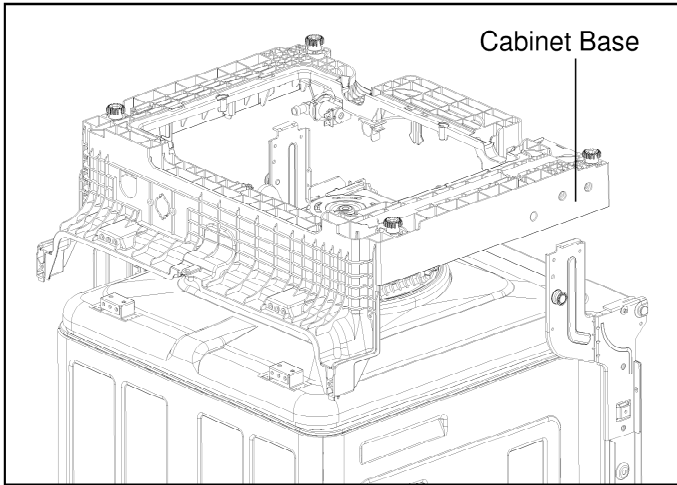

9. Cabinet Base

- 1) Remove 8 screws.
- 2) Lift it upward.

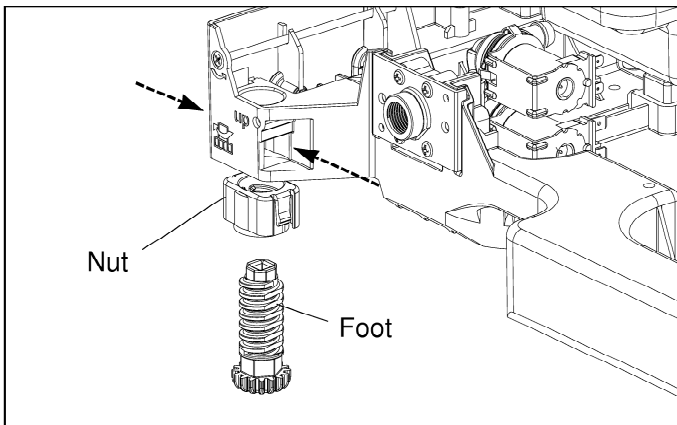

10. Foot & Nut

- 1) Pull the Foot twisting
- 2) Pull the Nut pushing the hook.

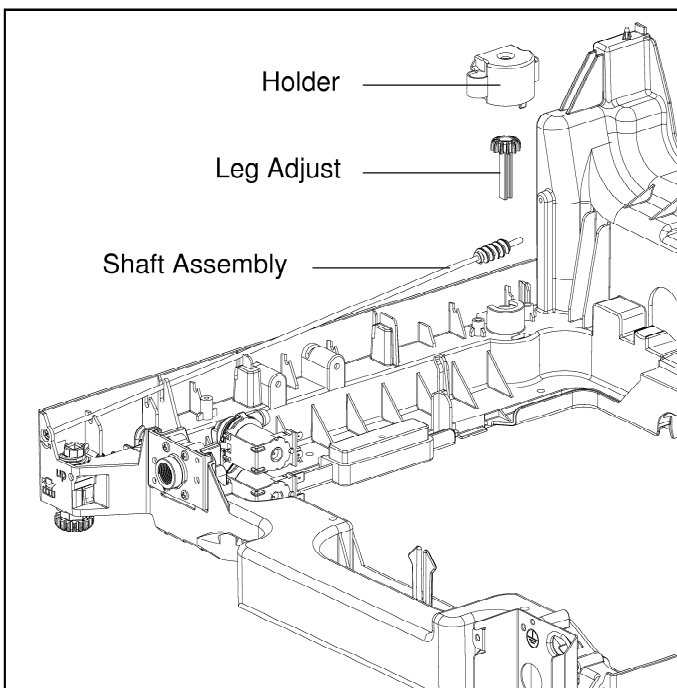

11. Rear Leg Adjustment System

- 1) Remove 2 screws.
- 2) Pull the Holder.
- 3) Pull the Leg Adjust.
- 4) Pull the Shaft Assembly.

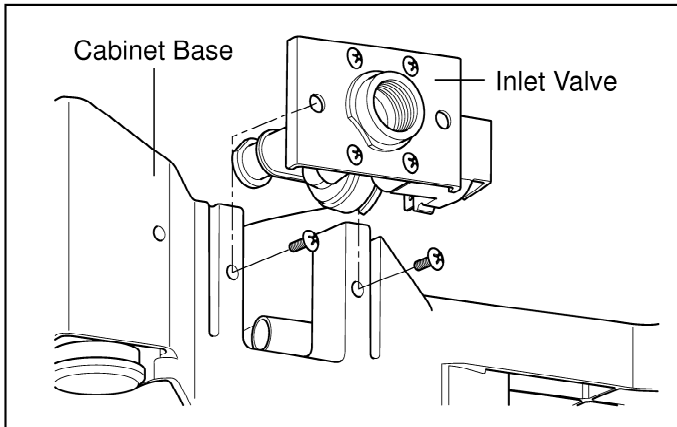

12. Inlet Valve

- 1) You can disassemble the Inlet Valve by removing the 2 screws.

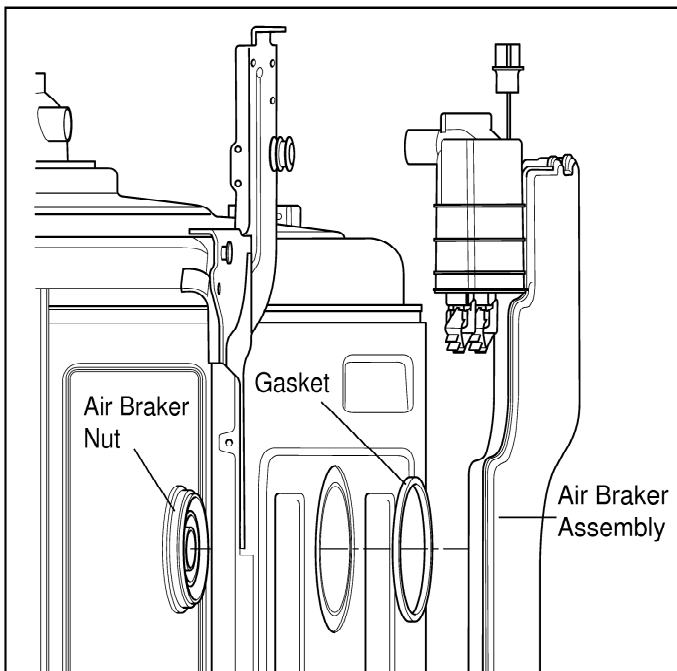

13. Air Braker Assembly

- 1) Disconnect the 3 hoses assembly.
- 2) Turn the Air Braker Nut counterclockwise.

Be careful the o-ring should not be lost.

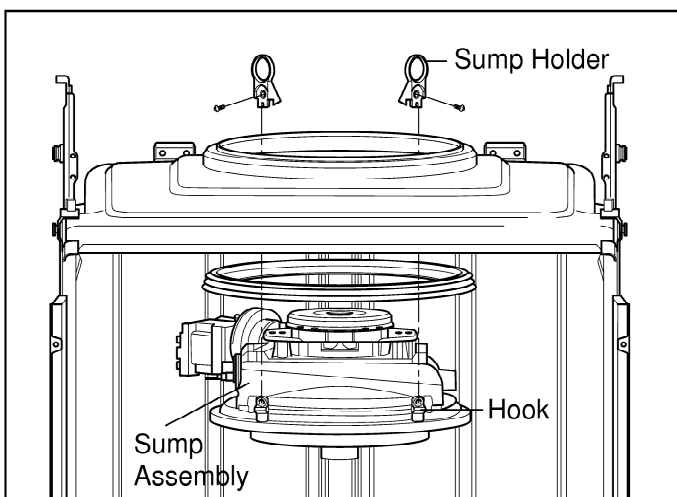

14. Sump Assembly

- ① Remove 2 screws.
- ② Remove the Sump Holder and push the Sump Assembly down with pulling aside Hook.

Be careful not to drop the Sump Assembly to the bottom.

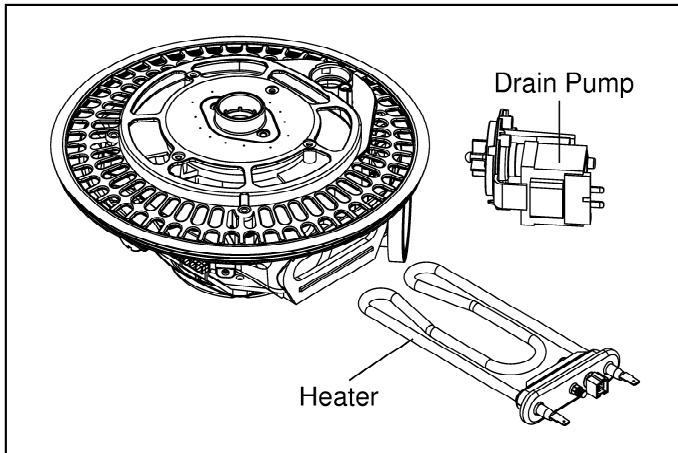

1) Heater & Drain Motor

- ① Pull the Heater out of the Sump after releasing the nut.
- ② Remove 3 screws.

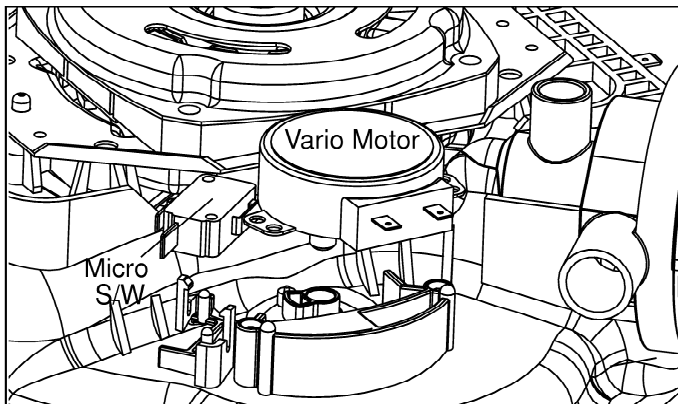

2) Vario Motor

- ① Remove 2 screws for Vario Motor.
- ② Pull the Vario Motor and Micro S/W.

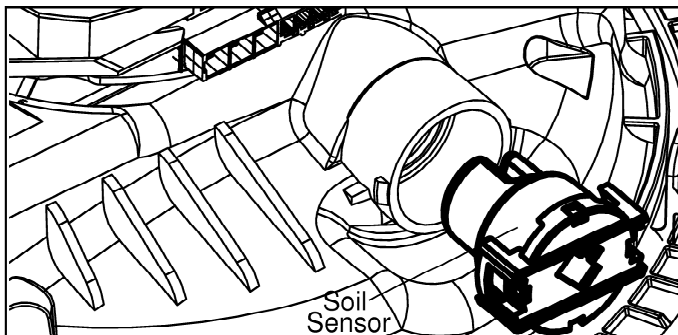

3) Soil Sensor

- ① Pull the Soil Sensor.

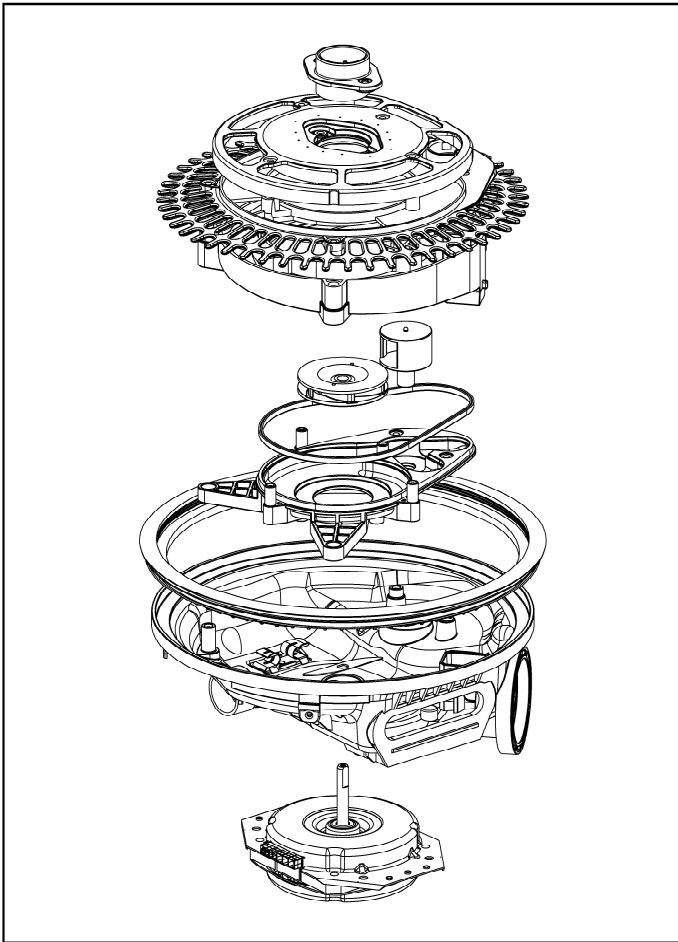

When you reassemble the Sump Assembly, be careful not to kink, tear and take off the seals.

15. Holder Supporter, Tub Packing and Hinge Supporter Assembly.

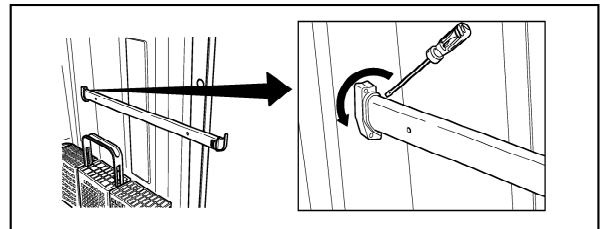

Rotate the screwdriver, after slide it into the gap between Stopper Roller and Rail Roller.

LDF 7811/7810/5811/6810 Series

You must take off Stopper Roller(F117) by – screwdriver to change the Rail Assembly. (Stopper Roller could be broken while you are taking off. So you should be careful not to be hurt and have extra stopper rollers ready at servicing at all times)

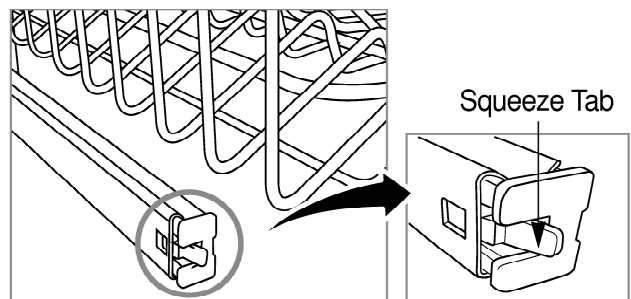
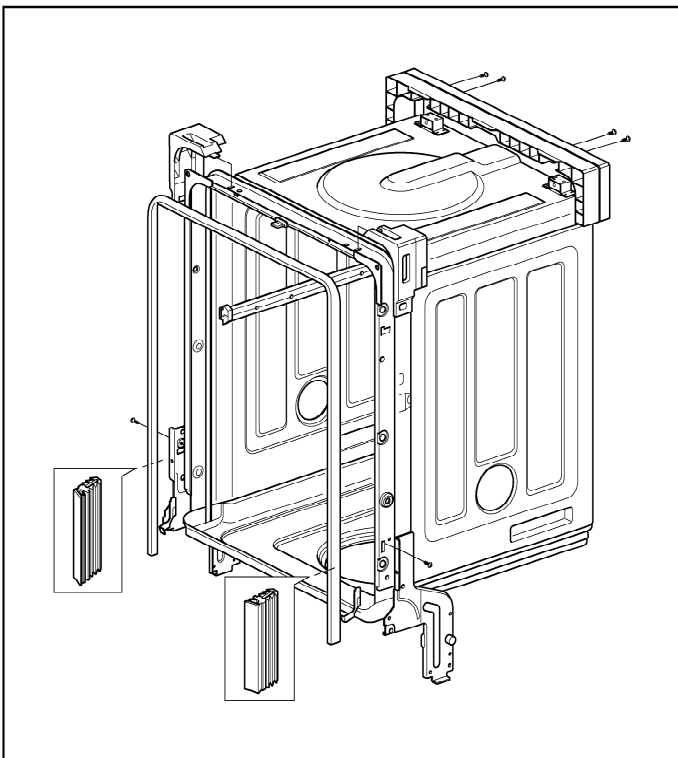







LDF 8812 Series

1. Pull the upper rack out until it stops.
2. Squeeze the tab of the stopper and pull out. Be careful the upper rack does not fall off the rail while pulling out the stopper.
3. Pull the upper rack out of the slides.

8.TROUBLE SHOOTING METHODS

A. TROUBLE SHOOTING ACCORDING TO DISPLAYED ERROR MESSAGE

ERROR MESSAGE	POSSIBLE CAUSE FOR ERROR OCCURRENCE	REMEDY
<p>INLET ERROR</p>  <p>displayed</p> <p>Condition Not reached to the normal water level in spite of 10 min. water supply</p>	<ul style="list-style-type: none"> • The Water Supply Tap is closed. • The Water Supply is shut off. • The Inlet Hose is kinked. • The Water Pressure is very low. (below 10 psi) • Inlet Valve is OK? • The filter of Inlet Valve is clogged by impure water. • The Hall sensor is OK? • The Impeller of Air Guide is bound. 	<ul style="list-style-type: none"> • Take action on Water Supply device. • Measure the electric resistance of Inlet Valve. (950-1300 Ω) • Clean the filter of Inlet Valve. • Check the frequency of Inlet Water by the Test Mode. • Replace the Air Braker.
<p>DRAIN ERROR</p>  <p>displayed</p> <p>Condition Not fully drained out in spite of 5 min. drain operation</p>	<ul style="list-style-type: none"> • The Drain Hose kinked or blocked. • Wiring connection is OK? • The drain outlet of sump is blocked. • The Drain Pump/Motor or circuit is troubled. 	<ul style="list-style-type: none"> • Remove the cause of kink or block. • Check the wiring connection. • Measure the electric resistance of Drain Motor. (20-40 Ω) • Replace the Drain Motor or repair the Circuit.
<p>LEAKAGE ERROR</p>  <p>displayed</p> <p>Condition The excessive RPM of Washing Motor happened during Wash cycle due to water leakage.</p>	<ul style="list-style-type: none"> • Water leakage in Hose connections. • Water is leaked by damages. • The Motor Water Seal leakage of Sump assembly. • The height of Drain Hose connection (sink-Drain Hose) is not over 20". • Impeller of the Washing Pump is worn away. 	<ul style="list-style-type: none"> • Replace the connections of Hose. • Check the point of damages and repair or replace the related parts. • Read the Installation Instructions (page 9) and fix it to the recommended Height. • Replace the Impeller of the Washing Pump.

ERROR MESSAGE	POSSIBLE CAUSE FOR ERROR OCCURRENCE	REMEDY
<p>EXCESS ERROR</p>  <p>displayed</p> <p>Condition Excessive water is supplied than normal water level.(Automatically drain Pump operated.)</p>	<ul style="list-style-type: none"> • The Inlet Valve is troubled. • The Controller is troubled. 	<ul style="list-style-type: none"> • Replace the Inlet Valve. • Repair or replace the Controller.
<p>THERMAL ERROR</p>  <p>displayed</p> <p>Condition The resistance of thermistor not normally out put.</p>	<ul style="list-style-type: none"> • The Inlet Water Temperature is very high. (over 194°F) • Wiring connection is OK? • The Thermistor is OK? 	<p>Check the temperature. (Test Mode)</p> <ol style="list-style-type: none"> 1) If the temperature is displayed, <ul style="list-style-type: none"> ① adjust the Inlet Water Temperature to 120°F. 2) If the temperature is not displayed, <ul style="list-style-type: none"> ① check the wiring connection. ② check the electric resistance of Thermistor. (11~14kΩ at 77°F) ③ Replace the PCB.
<p>MOTOR ERROR</p>  <p>displayed</p> <p>Condition The Motor is working abnormally.</p>	<ul style="list-style-type: none"> • Wiring connection is OK? • The Impeller of Washing Pump is locked. • The rotor of Washing Motor is locked. • The Blade is locked. 	<ul style="list-style-type: none"> • Check the wiring connection. • Replace the cause of restriction. • Replace the Washing Motor. • Replace the PCB.
<p>HEATER ERROR</p>  <p>displayed</p> <p>Condition The water is not heated or the temperature in the Tub is overheated to over 194°F</p>	<ul style="list-style-type: none"> • The Circuit of Heater is troubled. • The Thermistor is troubled. • The Heater is shorted. • The Relay Circuit is troubled. 	<ul style="list-style-type: none"> • Repair the Circuit of Heater. • Replace the Thermistor. • Replace the Heater. • Repair the Relay Circuit..

B. TROUBLE DIAGNOSES AND REPAIR BY SYMPTOM

No Power on when the power button pressed.

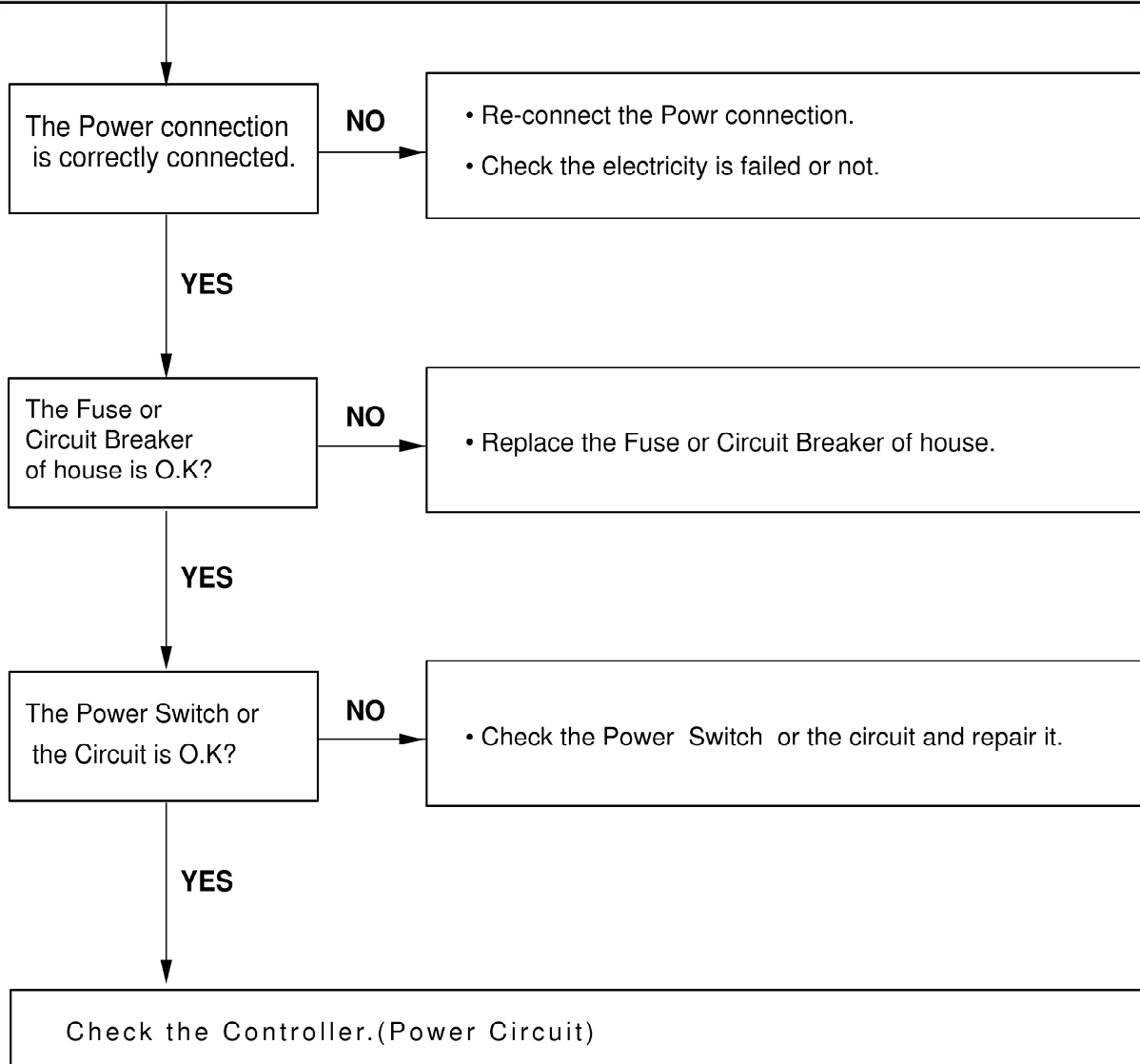

The Wash Pump/Motor does not run.

The Door is tightly closed?

NO

- close the Door tightly.
- Check the Door Switch in Latch Handle.

YES

The Wiring connections is OK?

NO

- Re-connect the wiring connections related to the Washing Motor.

YES

The Blade is not locked by a small and sharp object?

NO

- Remove the cause of lock or replace the Blade.

YES

Replace the Wahing Pump/Motor

Washing Results are not Satisfactory

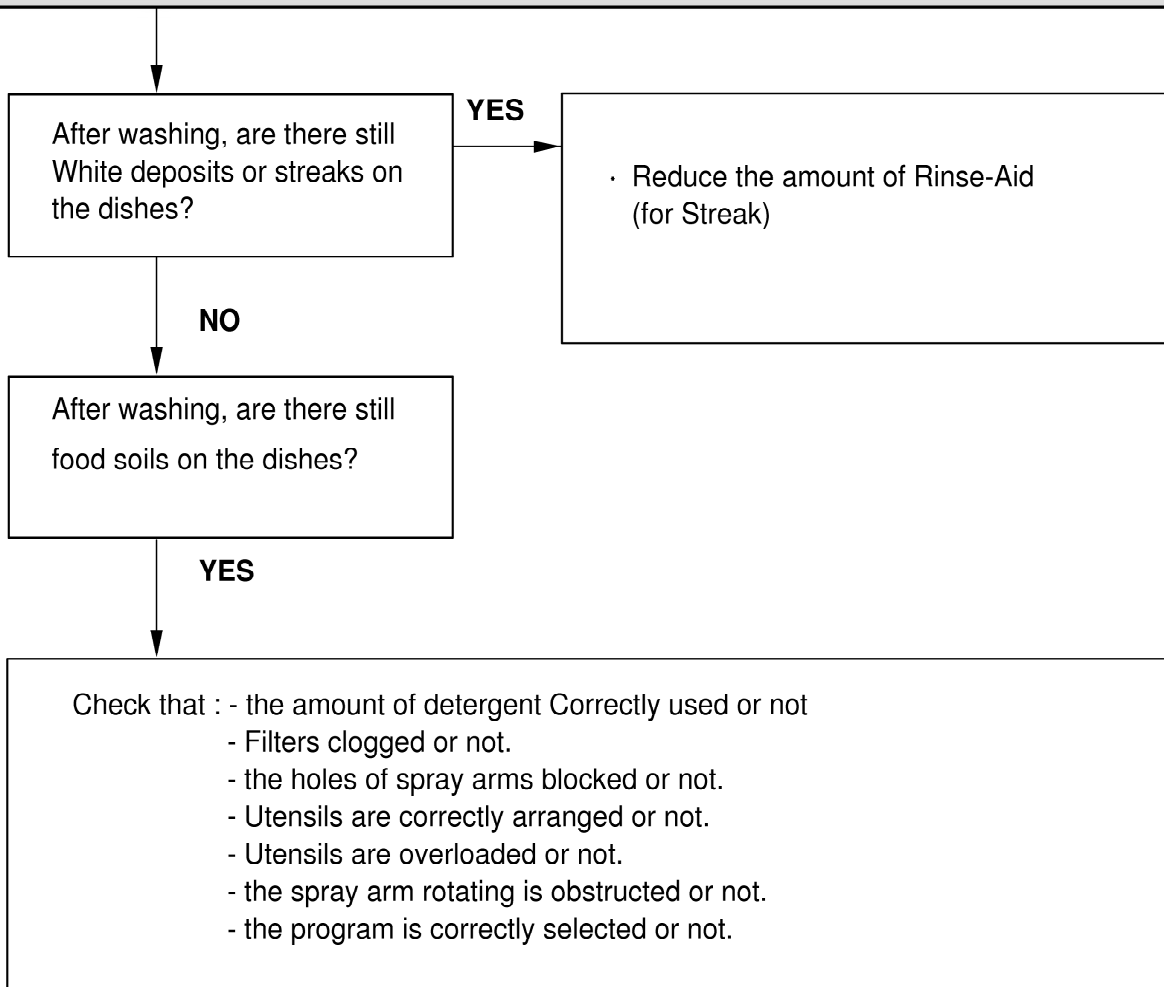

Dry Results are not satisfactory

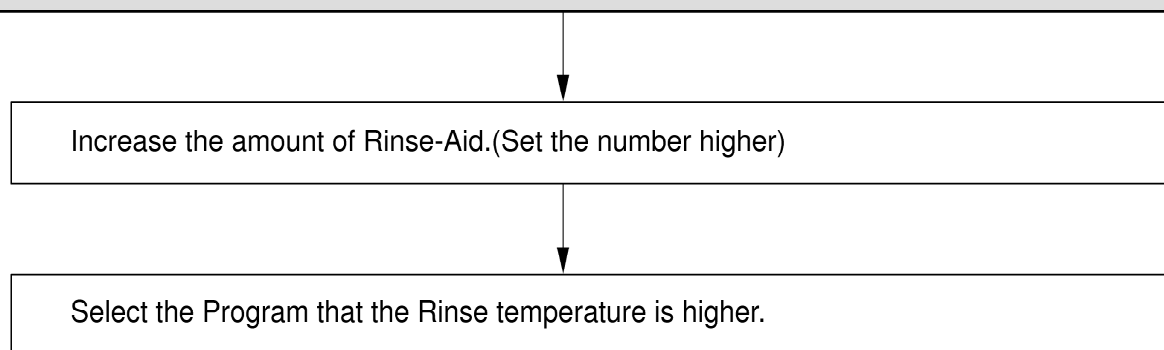

Power Button not automatically off after operation.

Check the button is blocked by foreign materials.

Check the Power Switch.(Replace it, if necessary.)

Check the Controller.(Replace it, if necessary.)

9. INSTALLATION INSTRUCTION

Step 1: PREPARE CUPBOARD OPENING

1. This dishwasher is designed to fit a standard dishwasher opening as shown below.
2. Select a location as close to sink as possible for easy connections to water and drain lines.
3. The dishwasher should not be installed more than 10 ft. (3m) from the sink for proper drainage.
4. If dishwasher is to be installed in a corner, a minimum of 2 in. (50mm) is required between the dishwasher and an adjacent wall.

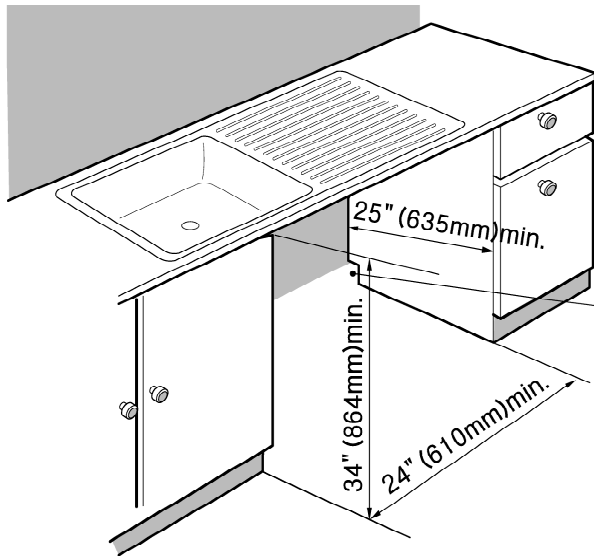

If dishwasher will sit directly on subflooring, subfloor should be sealed with a waterproof paint or sealer to prevent damage from steam.

Drill a 1-1/2" (38mm) dia hole or cut out for drain hose, inlet hose and electrical cables on either side.

approx. 4" (100mm, W) X 4" (100mm, H)
These openings must be within 4" (100mm) from the floor and 1-5/8" (40mm) from the back wall. If there is a floor in the cabinet under the sink, it will also be necessary to drill or cut through the floor to connect the water and drain under the sink.

- Ensure the floor under the dishwasher is at the same level as the rest of the room to allow for any service requirements.

Step 2: PREPARE THE ELECTRICAL WIRING

▲ WARNING

For personal safety, remove house fuse or open circuit breaker before installation.
Do not use an extension cord or adapter plug with this dishwasher.
Electrical and grounding connections must comply with the national electrical code/provincial and municipal code and/or other local codes.

1. This appliance must be operated with correct voltage as shown in this manual and on the rating plate, and connected to an individual, properly grounded branch circuit, protected by time delay fuse. Wiring must be 3 wires including ground.
2. The wiring or cord should be in an accessible location adjacent to, and not behind the dishwasher and within 4 ft. (1.2m) of the dishwasher side.
3. The wiring or cord must be grounded properly, if in doubt, have it checked by a qualified electrician. No other appliance shall be connected to the same outlet by a double adapter or similar plug.
4. The wiring or cord must be oriented as shown in Figure A below.
5. Check the dishwasher for any damage before trying to install it.
6. Make sure water line and Electrical line are oriented in the bottom channels as shown in the figure below.
If you find any damage to the dishwasher, Please contact your dealer or builder immediately.

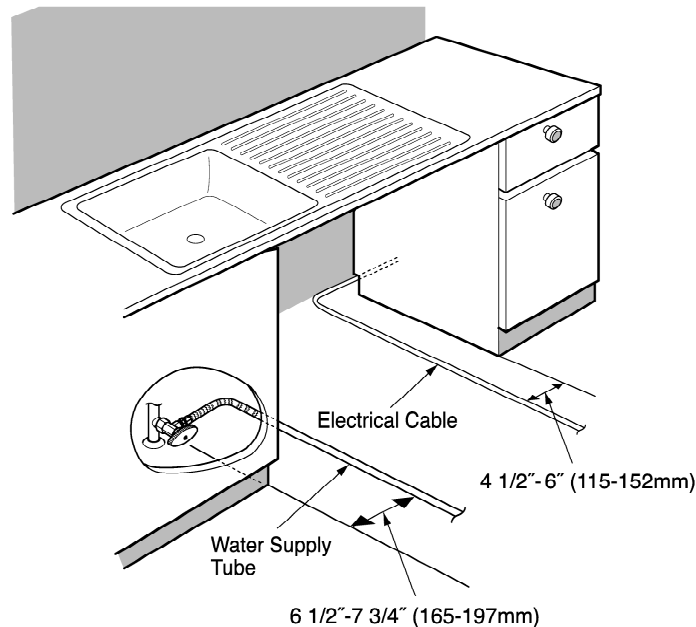

Step 3: PREPARE THE WATER SUPPLY CONNECTION

1. This dishwasher may be connected to either hot or cold water. If the water can not be maintained below 149°F (65°C), the dishwasher must be connected to cold water.
2. When connecting the dishwasher water line, sealing tape or compound should be used to avoid leaks.
3. When connecting the dishwasher water line, the house supply should be shut off.
4. The Water Supply Tube must be oriented as shown in Figure A on page 6.

Step 4: PREPARE DISHWASHER FOR INSTALLATION

1. Adjust the legs to the required height to fit properly under the countertop as shown below.
2. Check the level of dishwasher by using level.

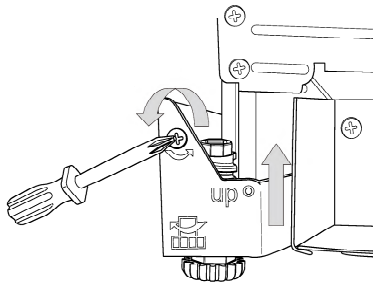

- Left side – turn the adjusting screw counterclockwise to lower the leg and raise the rear of the dishwasher.

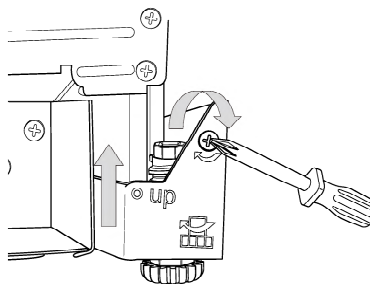

- Right side – turn the adjusting screw clockwise to lower the leg and raise the rear of the dishwasher.

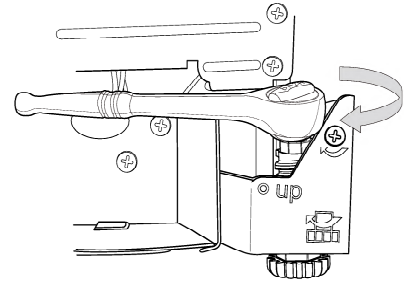

- Front feet can be adjusted from the top using a 1/4" square drive wrench.

Step 5: INSTALL THE DISHWASHER IN CUPBOARD

1. Remove the Lower Cover and orient dishwasher as shown below.
2. Before sliding the dishwasher into the cupboard opening, make all necessary height adjustments using the legs.
3. Slide the dishwasher into the cabinet opening carefully. Make sure that the drain hose inside the cabinet is not kinked.
4. Follow the instruction as in Figure B.

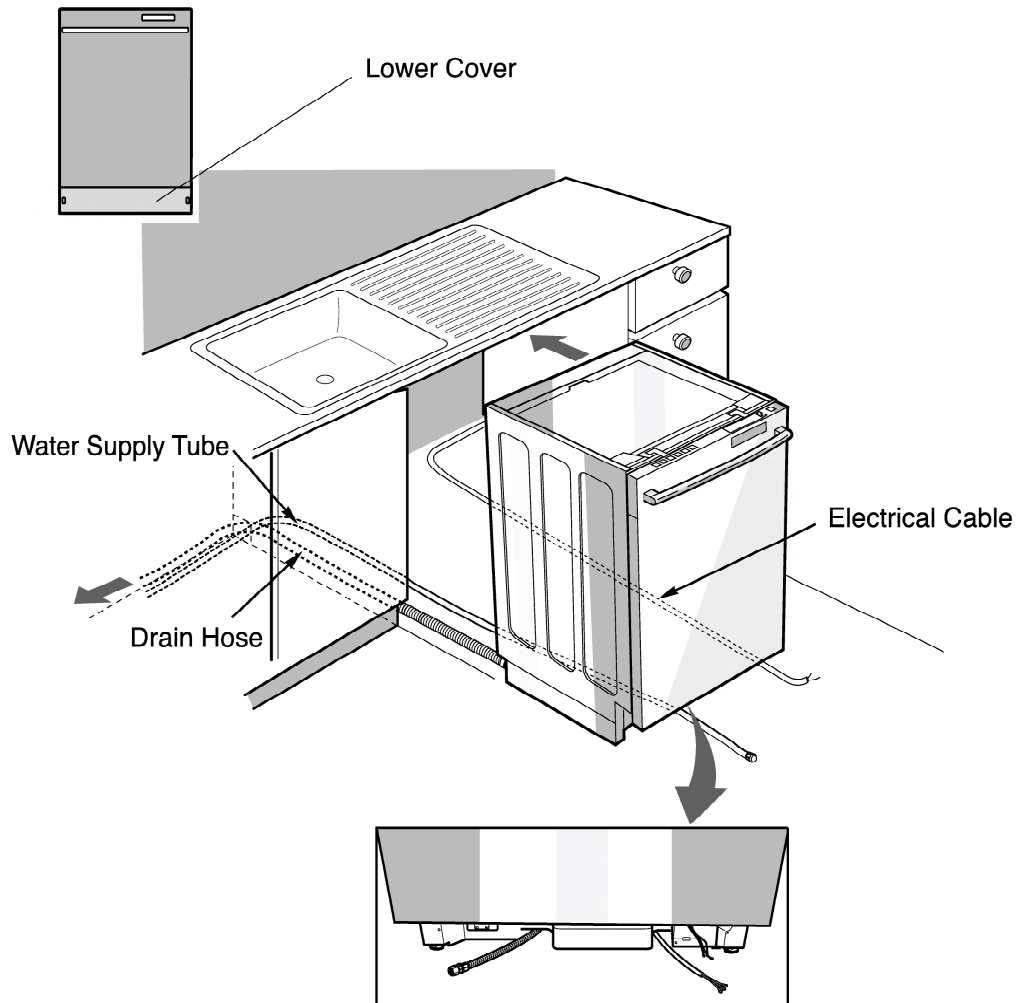

Step 6: DRAIN LINE CONNECTION

1. If the end of the drain hose does not fit to the drain line, use an adapter (not supplied) that must be resistant to heat and detergent and may be obtained from a plumbing shop.
2. There are 2 typical connections as shown in Figures C & D.
 - ① There may be other options than shown here for connection the drain hose. The drain connection must meet local plumbing regulations.
 - ② The S trap spigot must be drilled out cleanly and free of obstruction to its maximum internal diameter, if used for drainage.
 - ③ To prevent syphoning, one of the following instruction methods must be followed:

Figure C: Connection to Disposer or waste Tee.

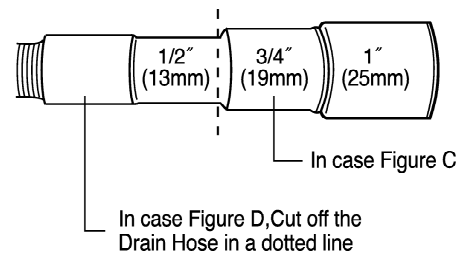
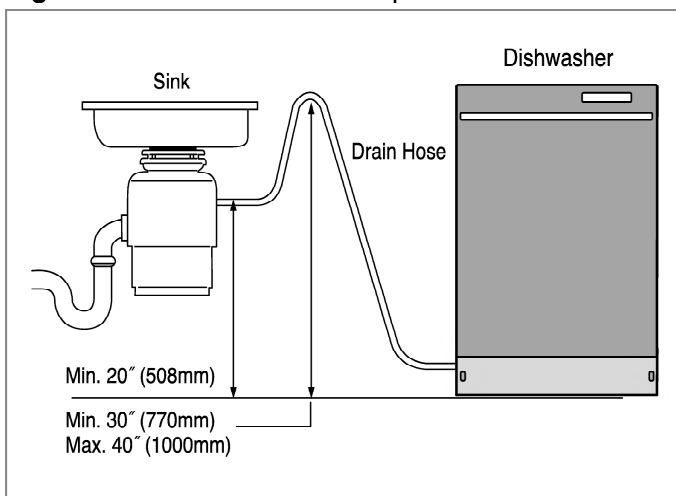
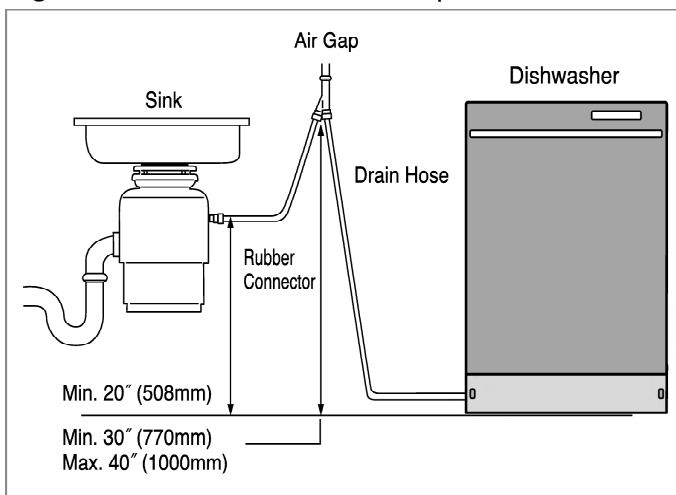

Figure D: Connection to Air Gap.



Drain Requirements

- Follow local codes and ordinances.
- Do not exceed 10 ft. (3m) distance to drain.
- Do not connect drain lines from other devices to the dishwasher drain hose.

Step 7: WATER SUPPLY CONNECTION

1. When connecting, sealing tape or sealing compound should be used to avoid water leaks.
2. Before connecting, turn off the water supply.
3. After fitting the Elbow into the Inlet Valve, slide the Flexible Stainless Tube or Copper Tube into the Elbow.
4. Tighten the nut and make sure that the line is not kinked or sharply bent.

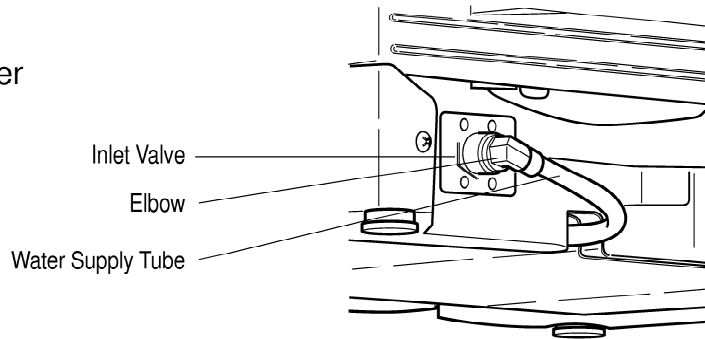

Step 8: ELECTRICAL POWER CONNECTION

1. Before beginning, turn off electrical power to the unit at the circuit breaker.
2. Remove the Junction Cover and then Install the Strain Relief.
3. Twist Wire Connectors tightly on the wires. Wrap each connection with Electrical tape.
4. Check again and make sure that all wires are connected correctly, black to black, white to white, green to green (ground to ground).
5. Replace the Junction Cover.

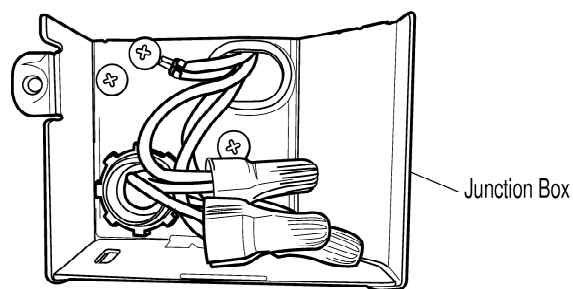
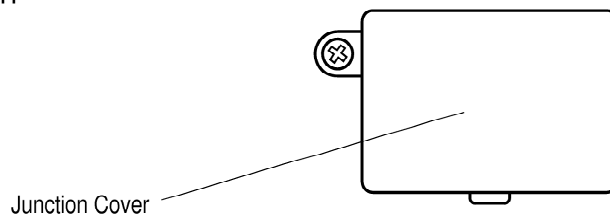

Step 9: FINAL CHECKS

1. Turn electrical power back on at the circuit breaker.
2. Turn house water supply back on.
3. Operate the dishwasher through one cycle (Quick cycle is recommended) to check for water leaks and operating conditions.
4. Replace the Lower Cover.

10. EXPLODED VIEW

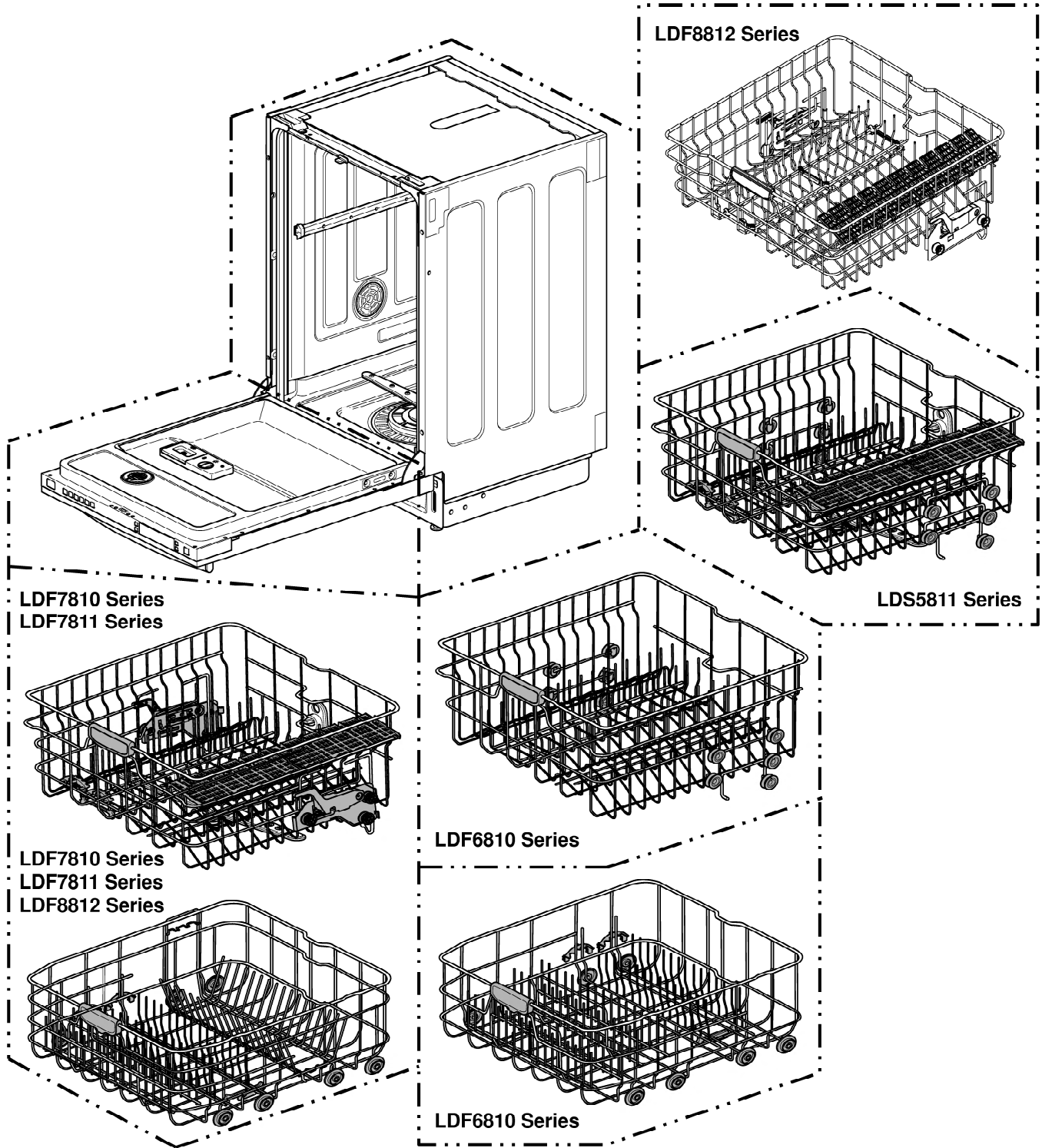

EXPLODED VIEW

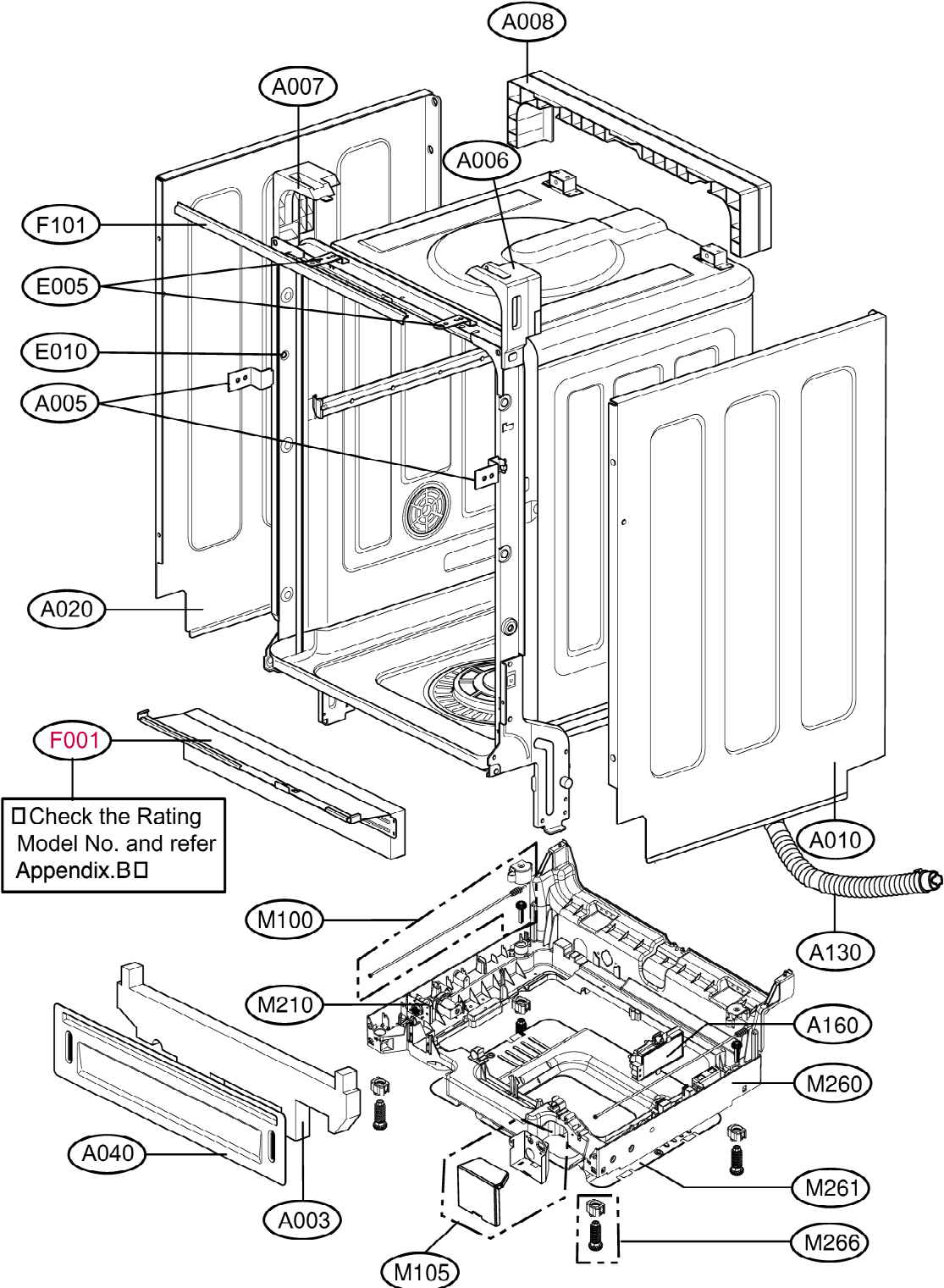

EXPLODED VIEW

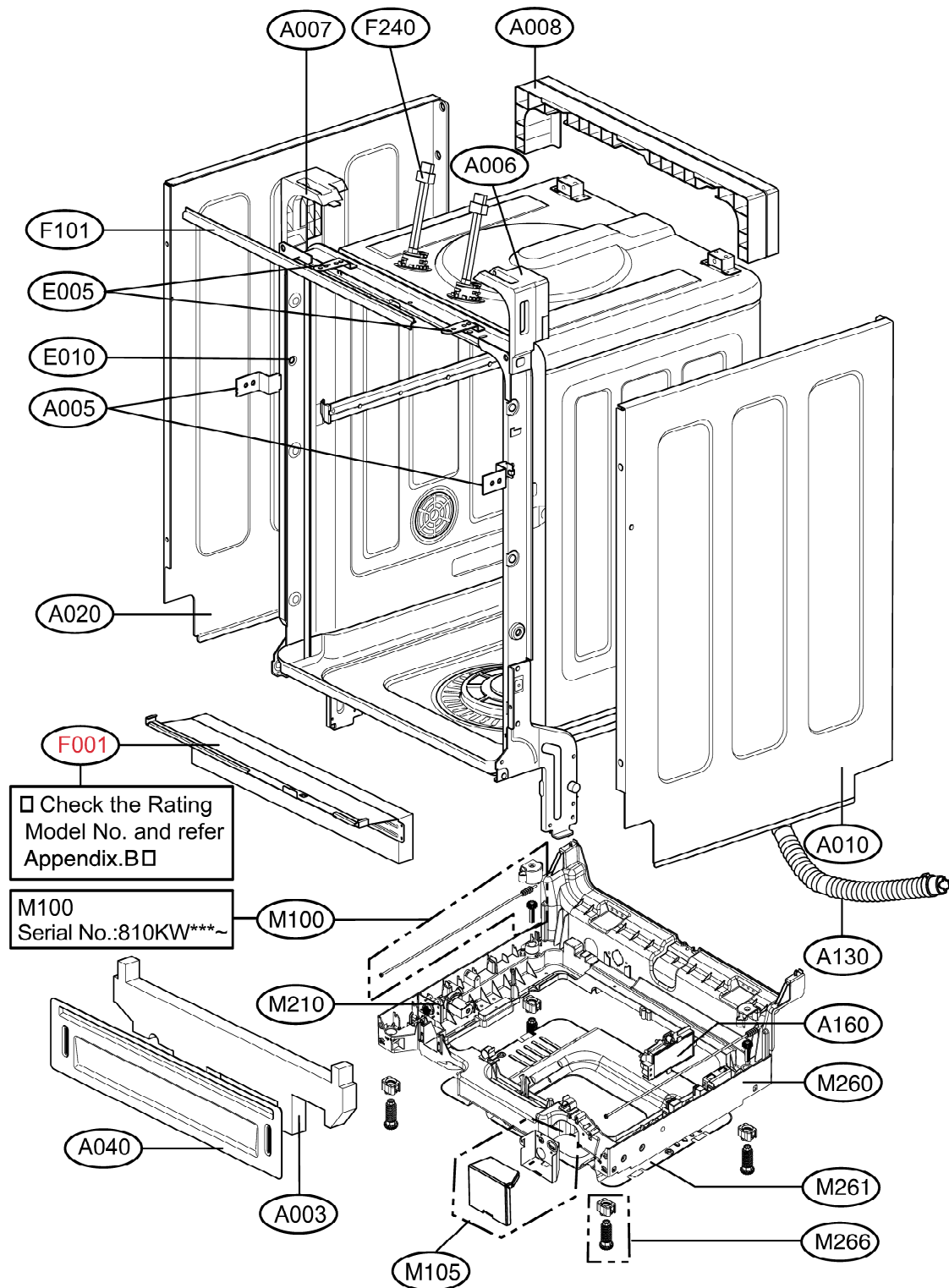

EXPLODED VIEW - TUB ASSEMBLY

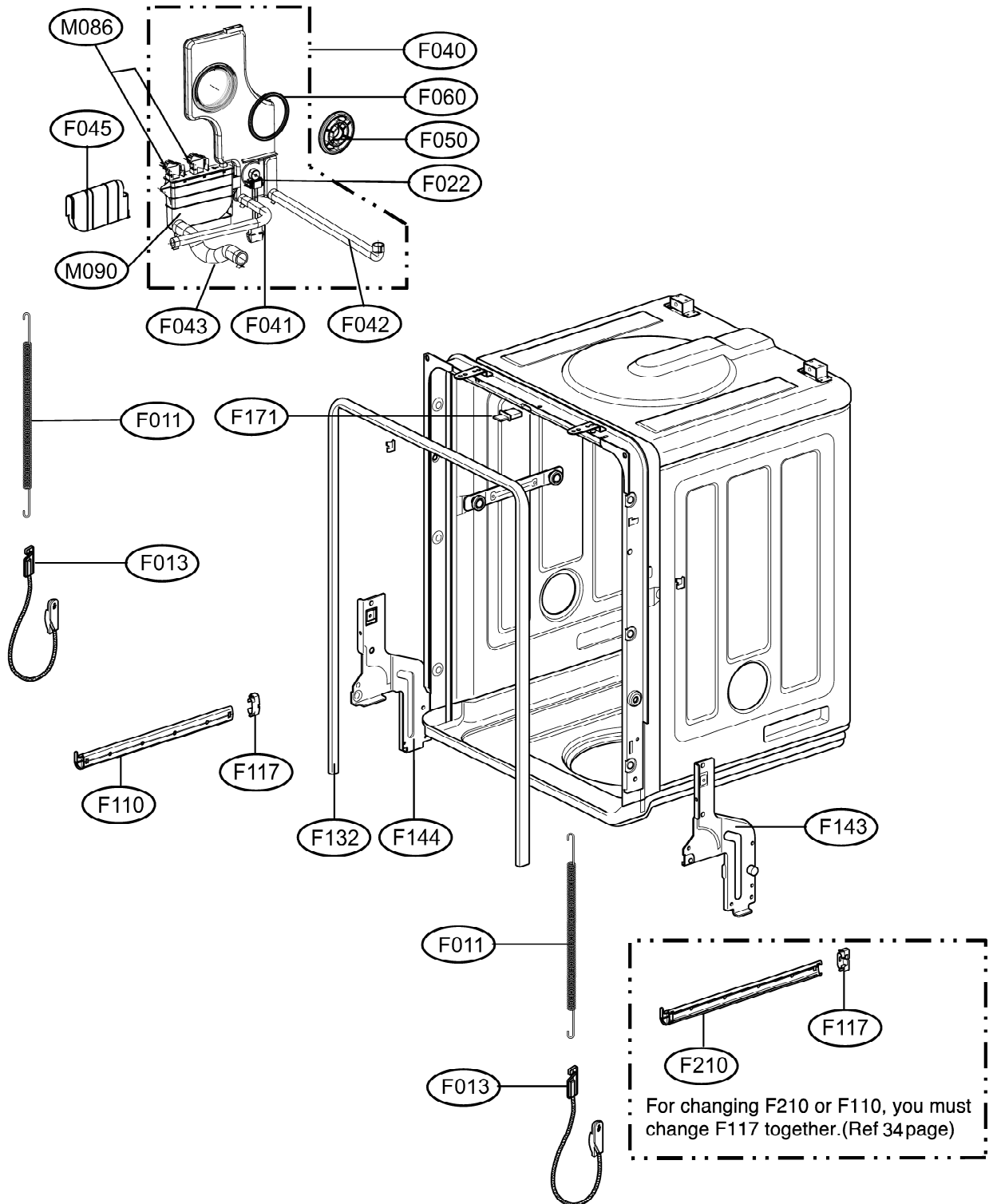

EXPLODED VIEW - TUB ASSEMBLY

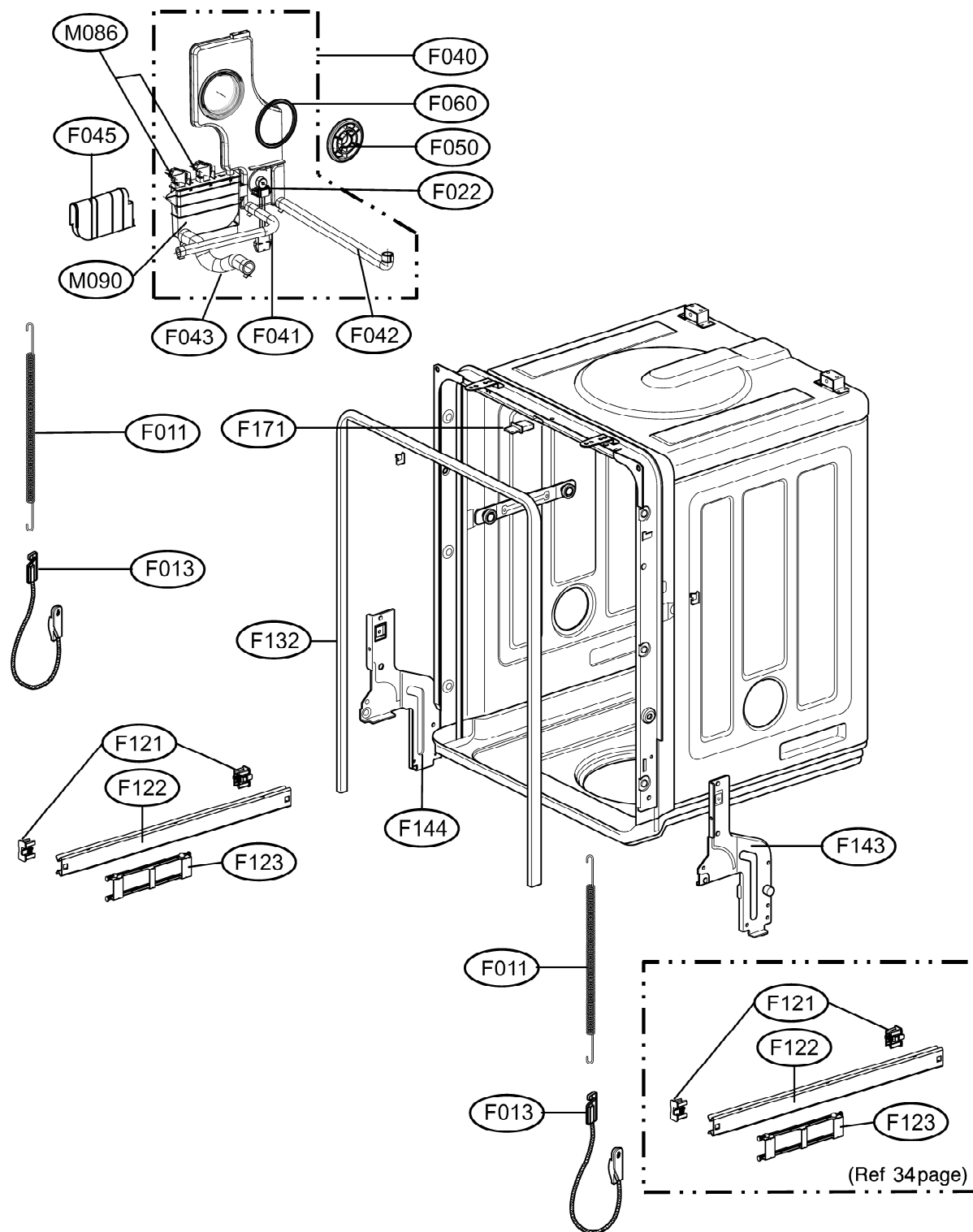

EXPLODED VIEW - RACK ASSEMBLY

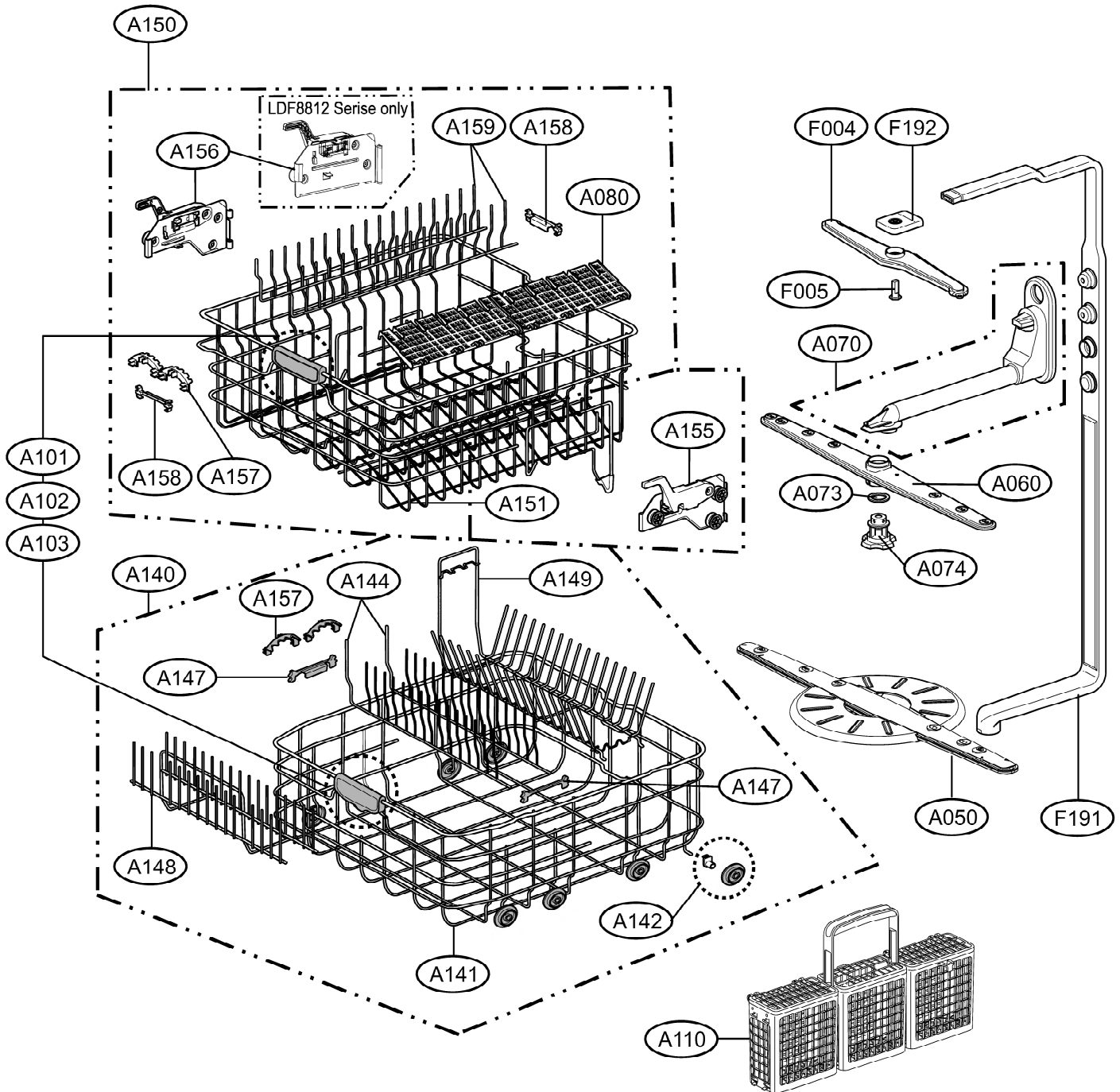

EXPLODED VIEW - RACK ASSEMBLY

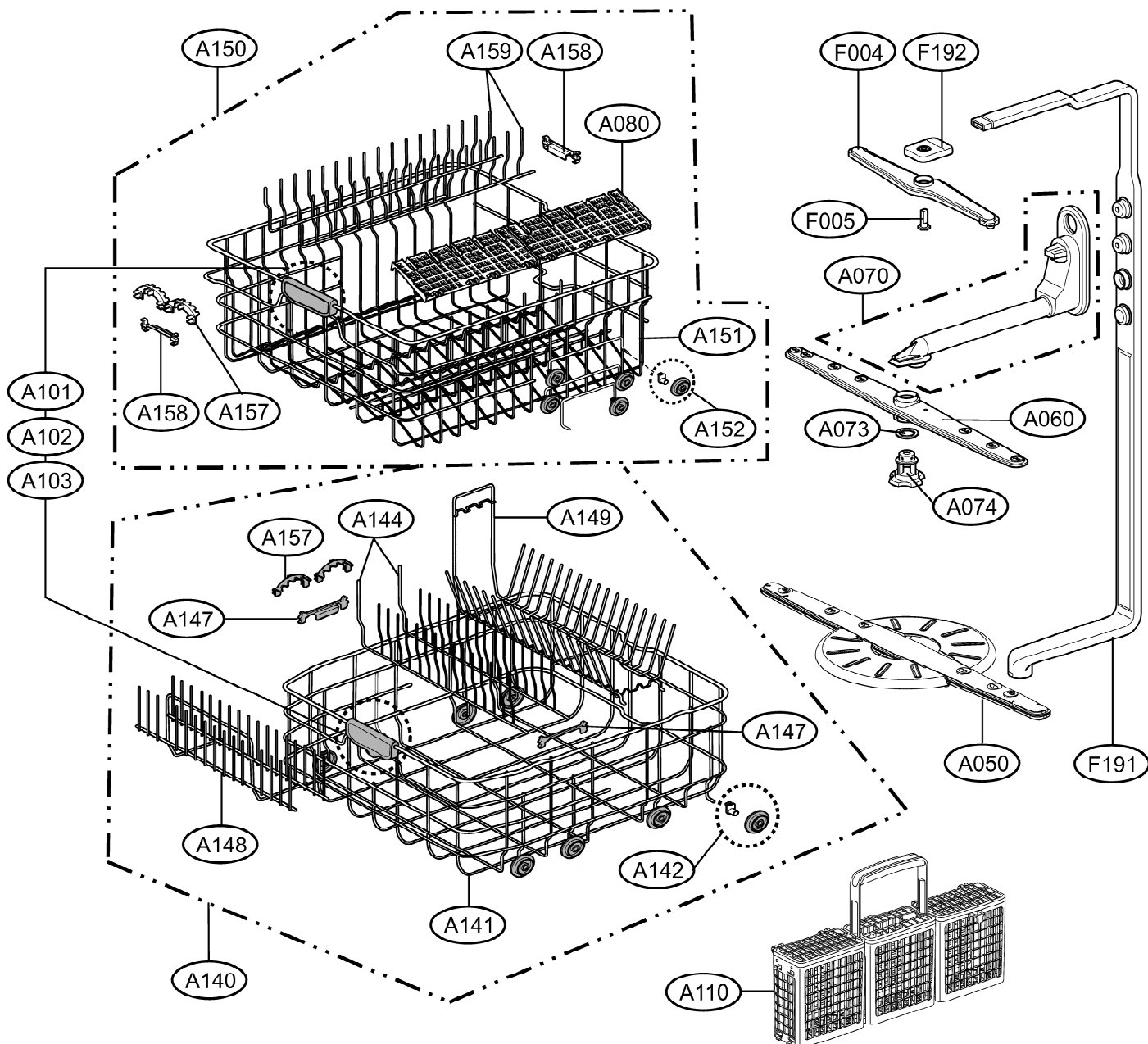

EXPLODED VIEW - RACK ASSEMBLY

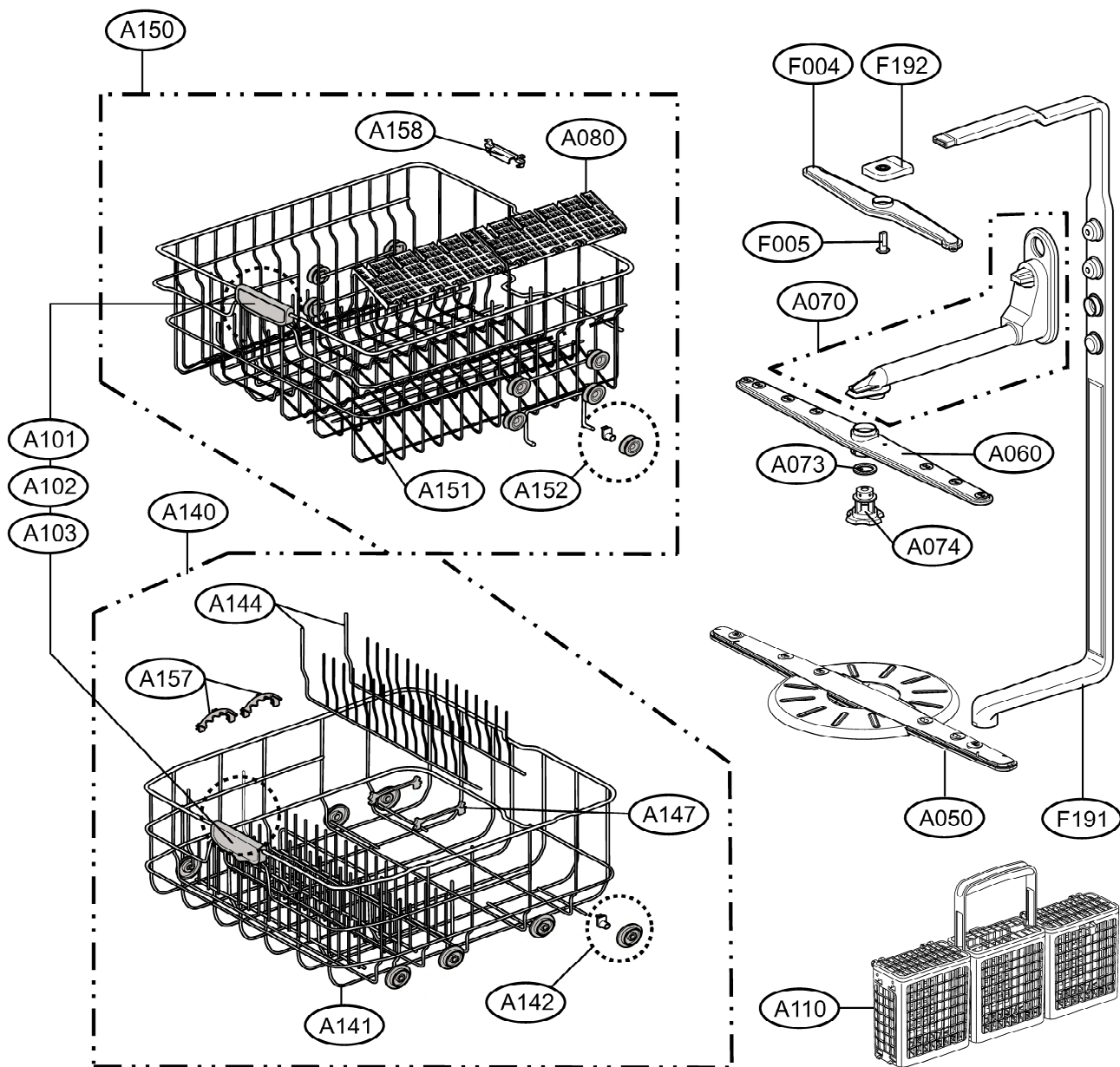

EXPLODED VIEW - PANEL ASSEMBLY / DOOR ASSEMBLY

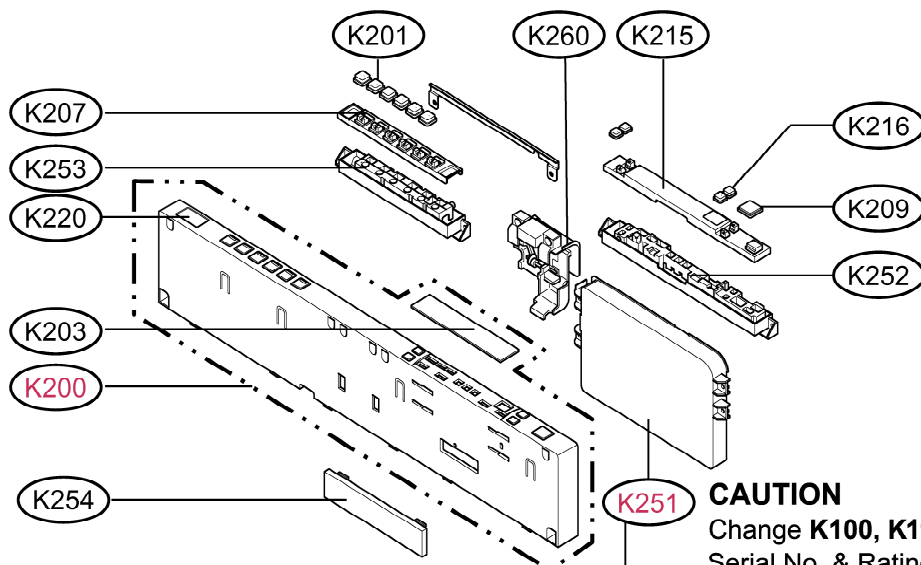

K200, F174
 □ Check the Rating Model No. and refer Appendix.B □

CAUTION

For change **K251**, you should be check Serial No.

Loc No.	601	602 ~ 612	701~
K251	6871DD1014A	6871DD1006E	6871DD1006J

CAUTION

Change **K100, K110, K124**, You should be check Serial No. & Rating Model

*Check the Rating Model No. and refer Appendix.A

Serial No.	~ 612#####	701##### ~	712##### ~
SVC Model	LDF7811XX	LDF7811XX/01	LDF7811XX/02
K100	4937DD1001A	4937DD1001B	4937DD1001C
K110	5835ED2002D	5835ED2002D	ABT35083802
K124	5232ED2001A	MJZ36939301	MJZ39902101

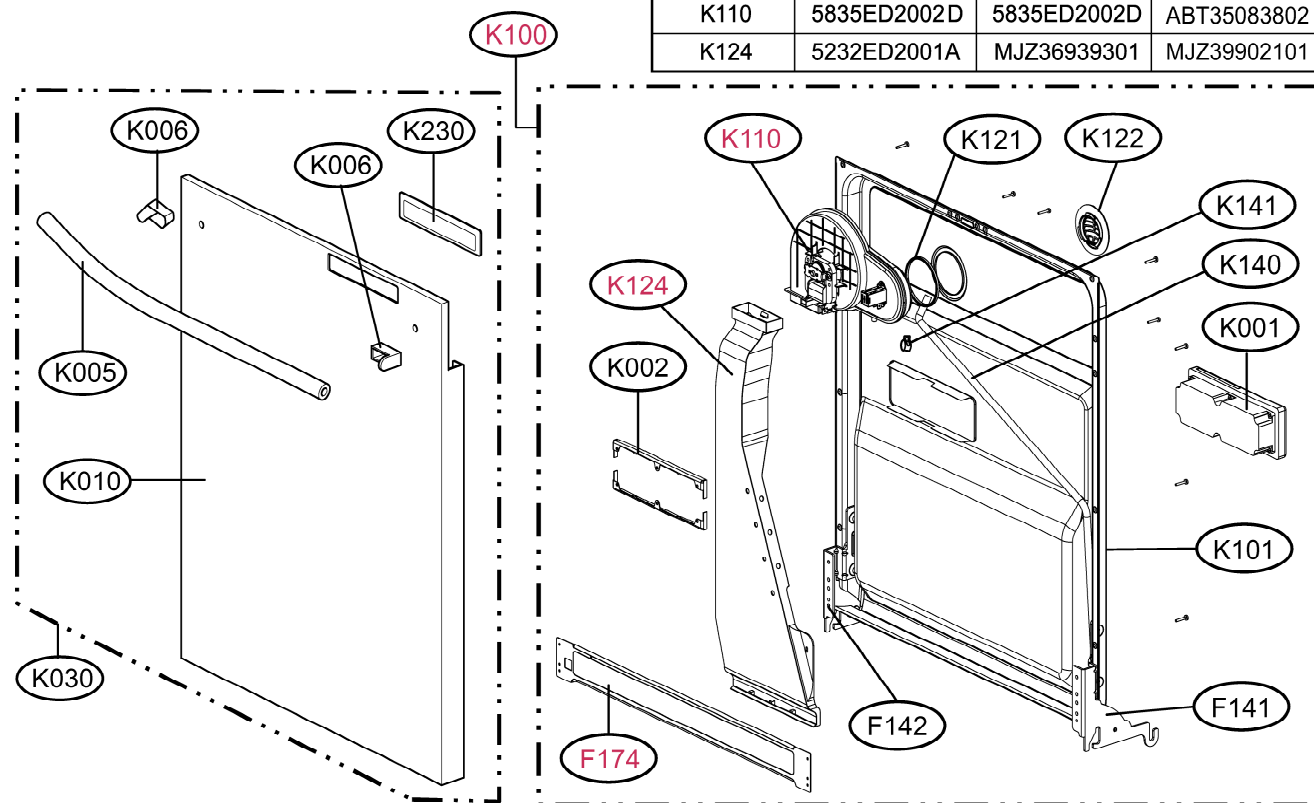

EXPLODED VIEW - PANEL ASSEMBLY / DOOR ASSEMBLY

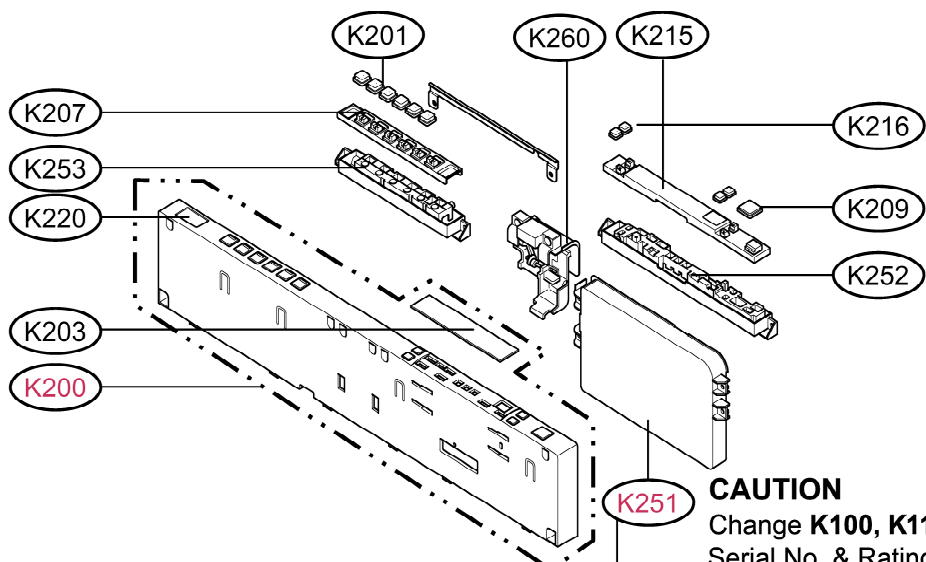

K200, F174
 □ Check the Rating Model No. and refer Appendix.B□

CAUTION

For change **K251**, you should be check Serial No.

Loc No.	601	602 ~ 612	701~
K251	6871DD1014C	6871DD1006G	6871DD1006L

CAUTION

Change **K100, K110, K124**, You should be check Serial No. & Rating Model

*Check the Rating Model No. and refer Appendix.A

Serial No.	~ 612#####	701##### ~	712##### ~
SVC Model	LDF7810XX	LDF7810XX/01	LDF7810XX/02
K100	4937DD1001A	4937DD1001B	4937DD1001C
K110	5835ED2002D	5835ED2002D	ABT35083802
K124	5232ED2001A	MJZ36939301	MJZ39902101

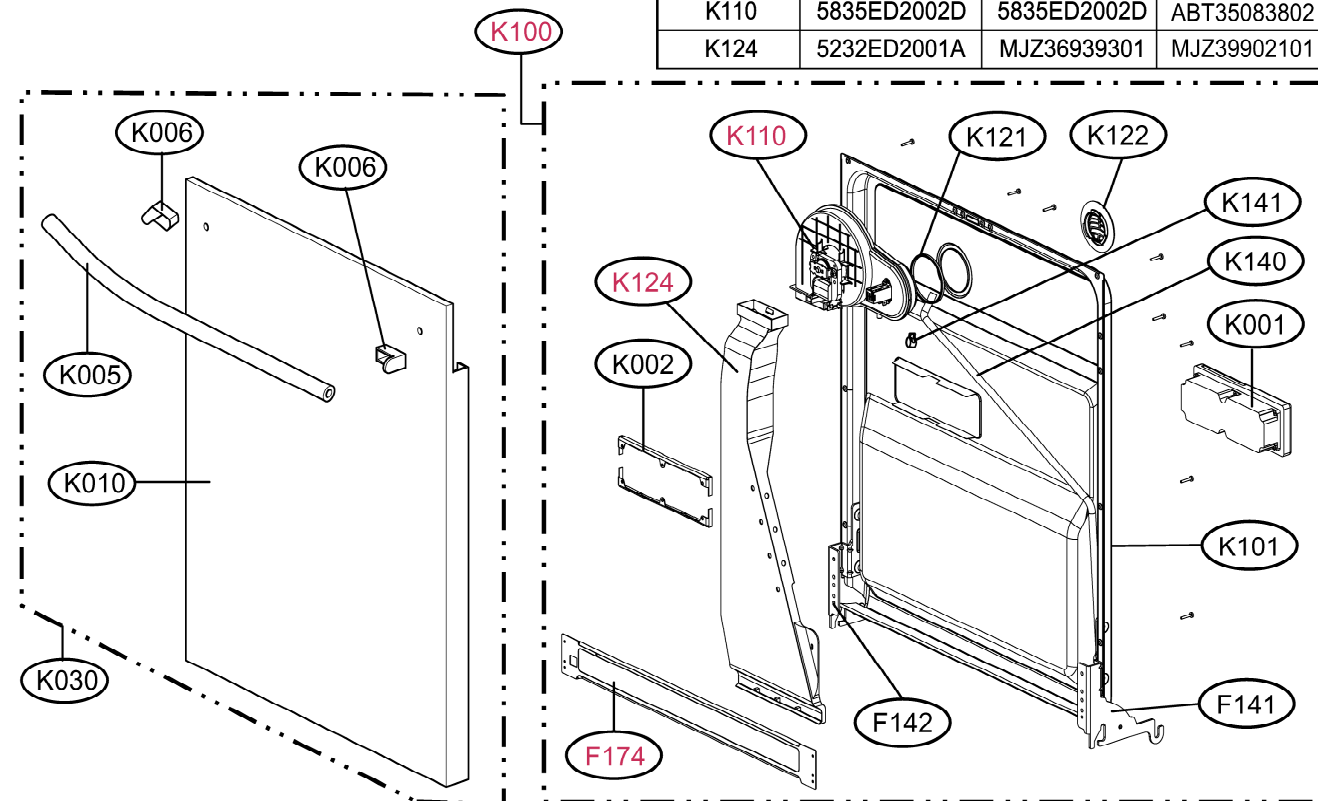

EXPLODED VIEW - PANEL ASSEMBLY / DOOR ASSEMBLY

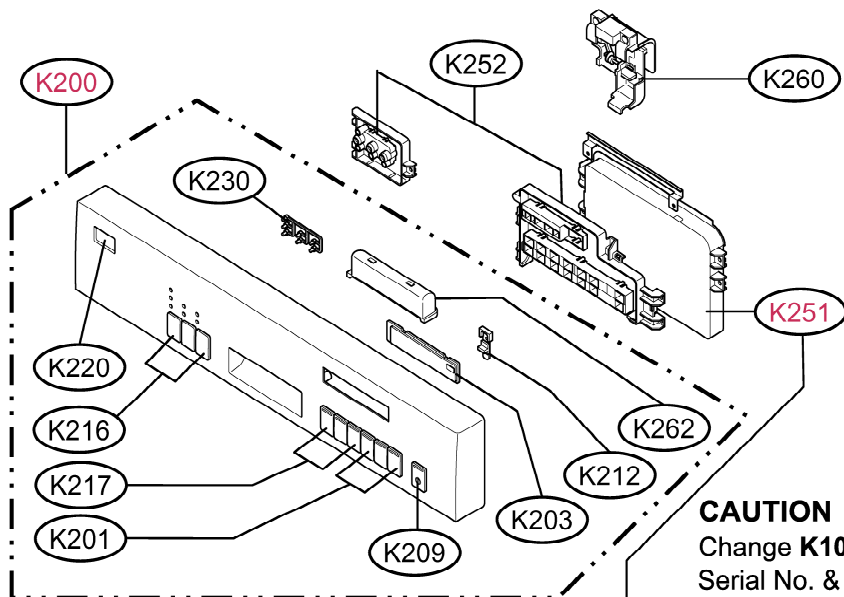

CAUTION

Change **K100, K110, K124**, You should be check Serial No. & Rating Model

*Check the Rating Model No. and refer Appendix.A

CAUTION

For change **K251**, you should be check Serial No.

Loc No.	601	602 ~ 612	701~
K251	6871DD1014B	6871DD1006F	6871DD1006K

Serial No.	~ 612#####	701##### ~	712##### ~
SVC Model	LDS5811XX	LDS5811XX/01	LDS5811XX/02
K100	4937DD1001A	4937DD1001B	4937DD1001C
K110	5835ED2002D	5835ED2002D	ABT35083802
K124	5232ED2001A	MJZ36939301	MJZ39902101

K010, K200, F174
 Check the Rating Model No. and refer Appendix.B

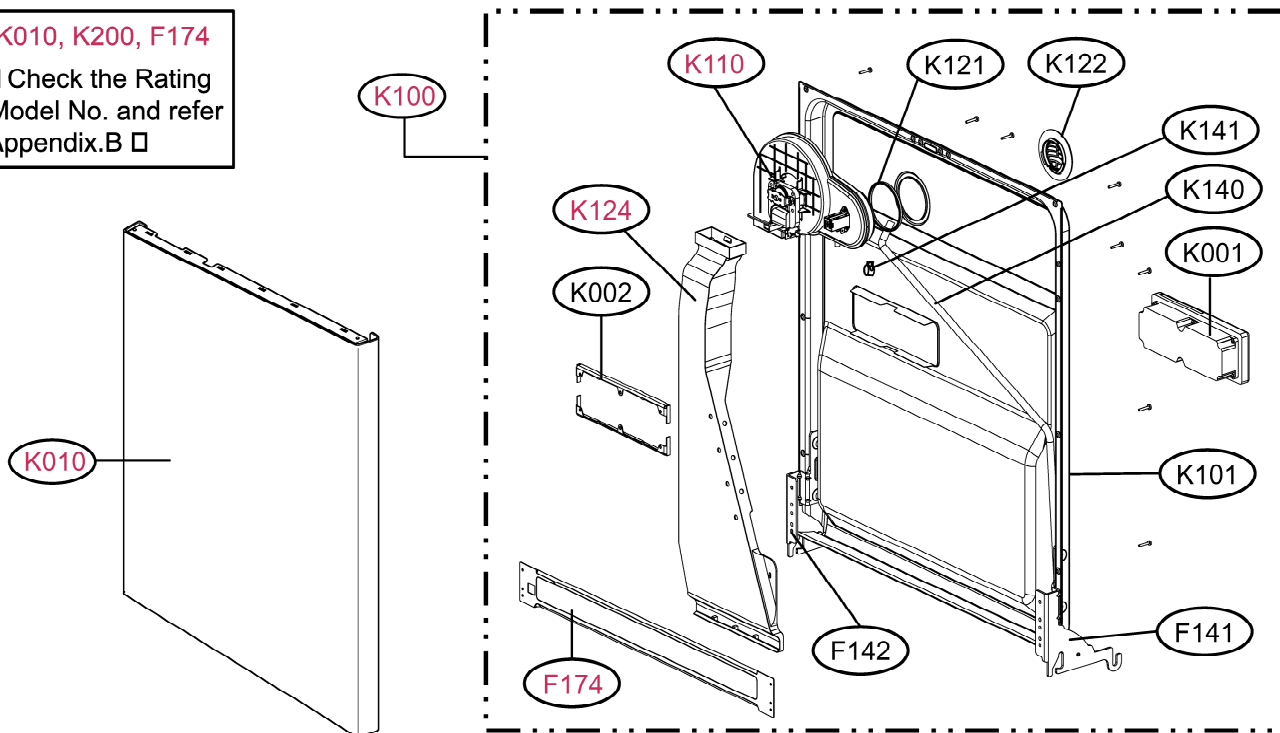

EXPLODED VIEW - PANEL ASSEMBLY / DOOR ASSEMBLY

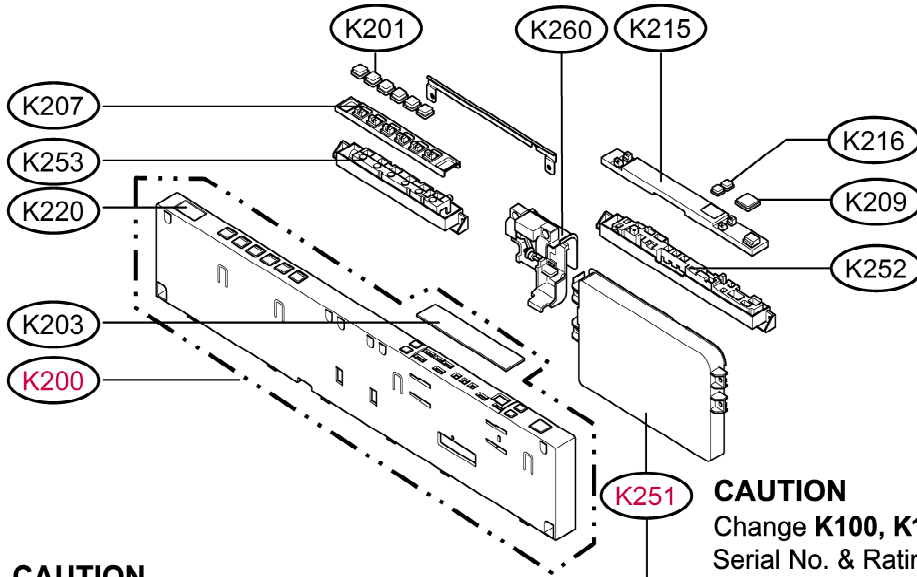

K200, F174
 □ Check the Rating Model No. and refer Appendix.B □

CAUTION

For change **K251**, you should be check Serial No.

Loc No.	601	602 ~ 612	701~
K251	6871DD1006D	6871DD1006H	6871DD1006M

CAUTION

Change **K100, K110, K124**, You should be check Serial No. & Rating Model

*Check the Rating Model No. and refer Appendix.A

Serial No.	~ 612#####	701##### ~ 711#####	712##### ~
SVC Model	LDF6810XX	LDF6810XX/01	LDF6810XX/02
K100	4937DD1001A	4937DD1001B	4937DD1001C
K110	5835ED2002D	5835ED2002D	ABT35083802
K124	5232ED2001A	MJZ36939301	MJZ39902101

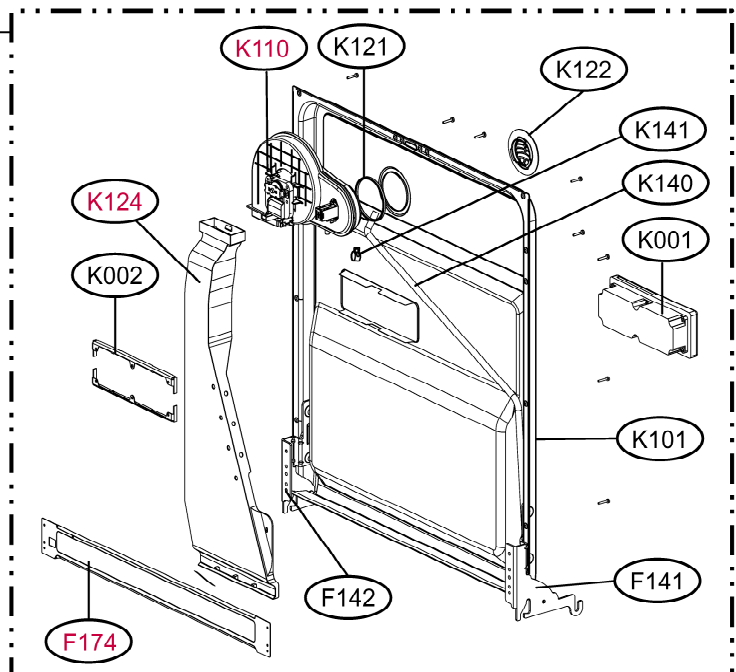
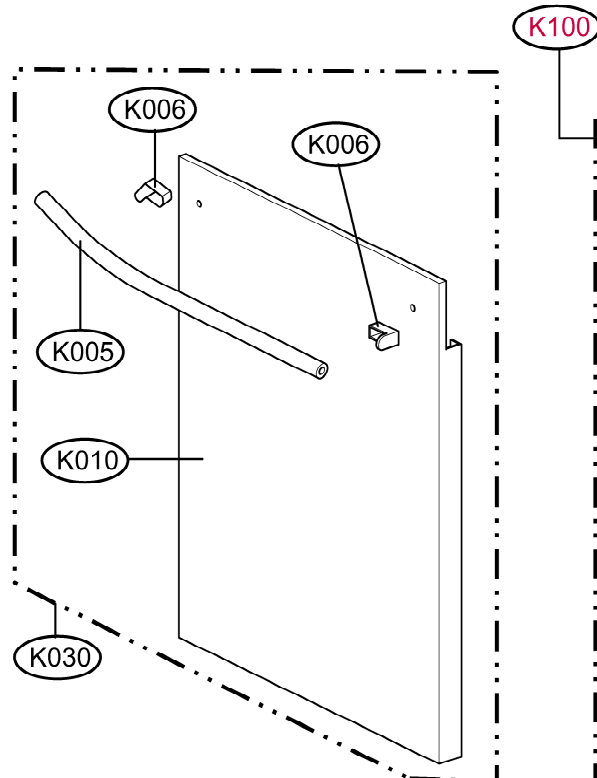

EXPLODED VIEW - PANEL ASSEMBLY / DOOR ASSEMBLY

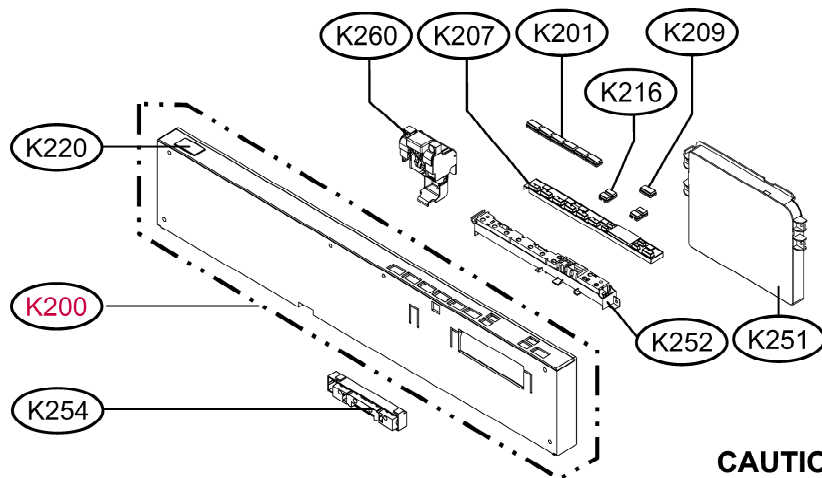

K200, F174
 □ Check the Rating Model No. and refer Appendix.B□

CAUTION

Change **K100, K110, K124**, You should be check Serial No. & Rating Model

*Check the Rating Model No. and refer Appendix.A

Serial No.	701##### ~ 711#####	712##### ~
SVC Model	LDF8812XX	LDF8812XX/01
K100	4937DD1001B	4937DD1001C
K110	5835ED2002D	ABT35083802
K124	MJZ36939301	MJZ39902101

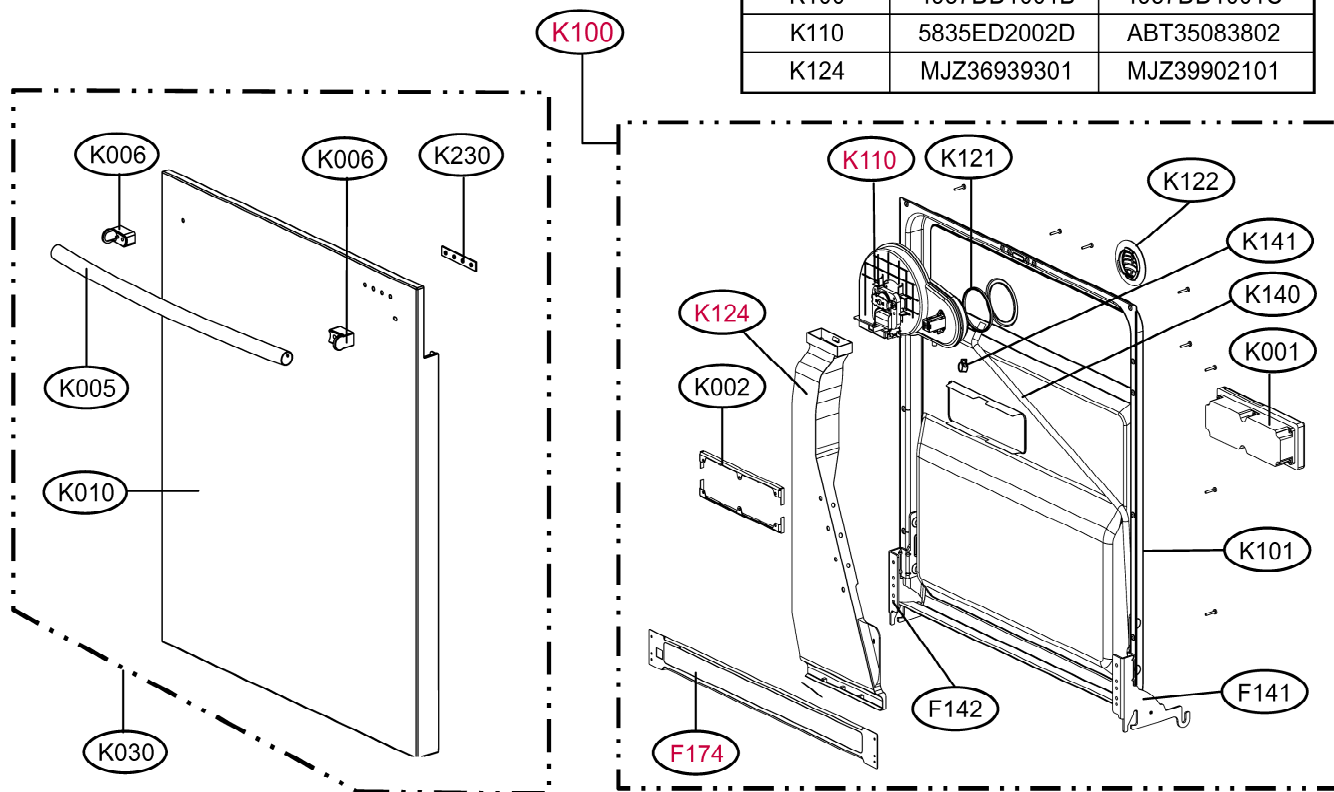

EXPLODED VIEW - SUMP ASSEMBLY

CAUTION

For change (M006) you should be check S/No.
Sump Assembly P/No.

Serial No.	601 ~ 612
Rating Model	LDF7811XX, LDF7810XX LDF6810XX, LDS5811XX
P/No.	3485ED1002B

※ Refer Part list in next page

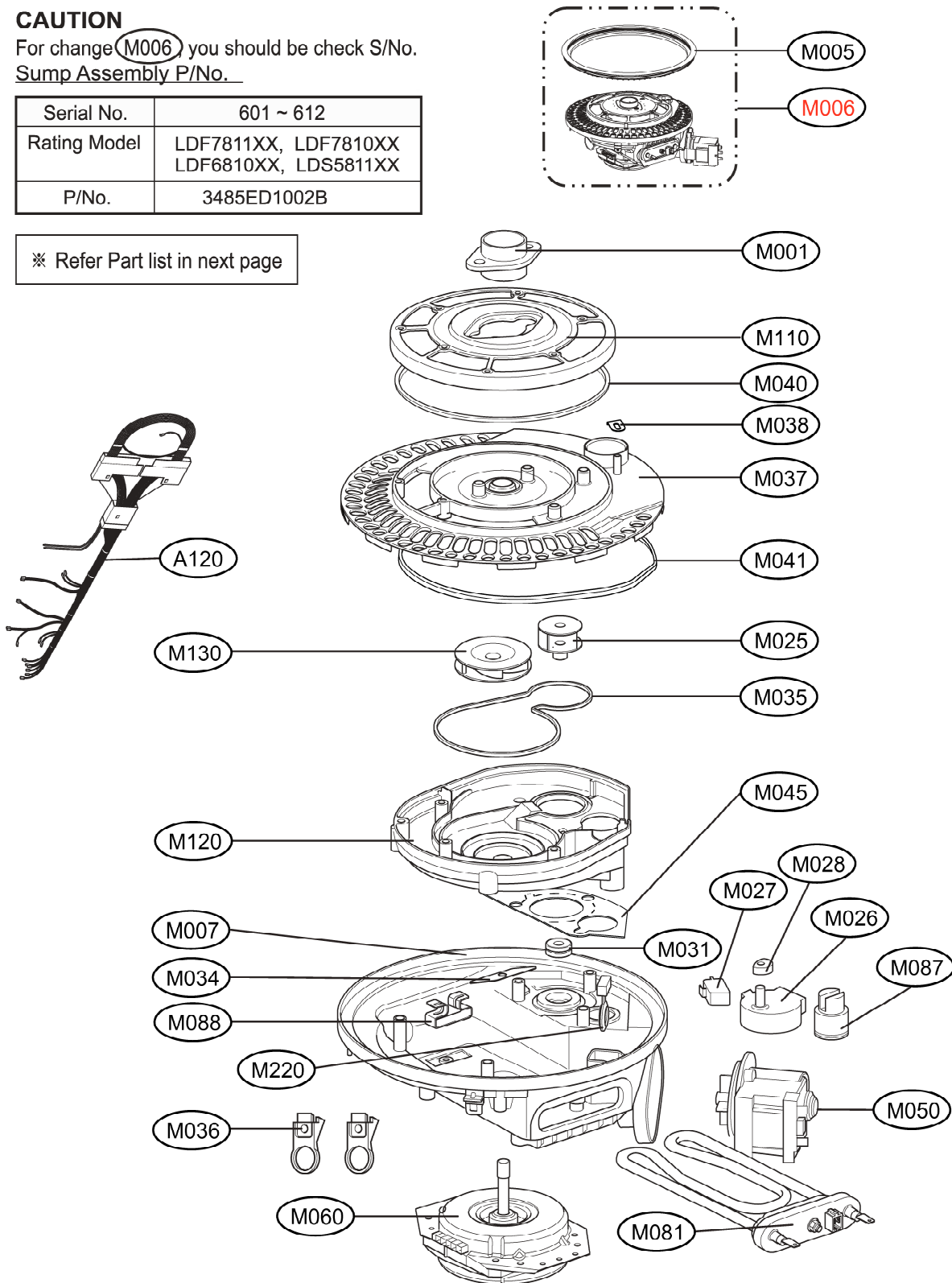

EXPLODED VIEW - SUMP ASSEMBLY

CAUTION

For change (M006), you should be check S/No.
Sump Assembly P/No. _

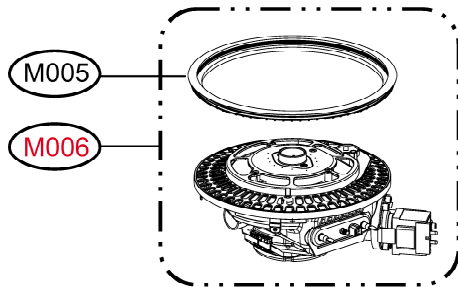

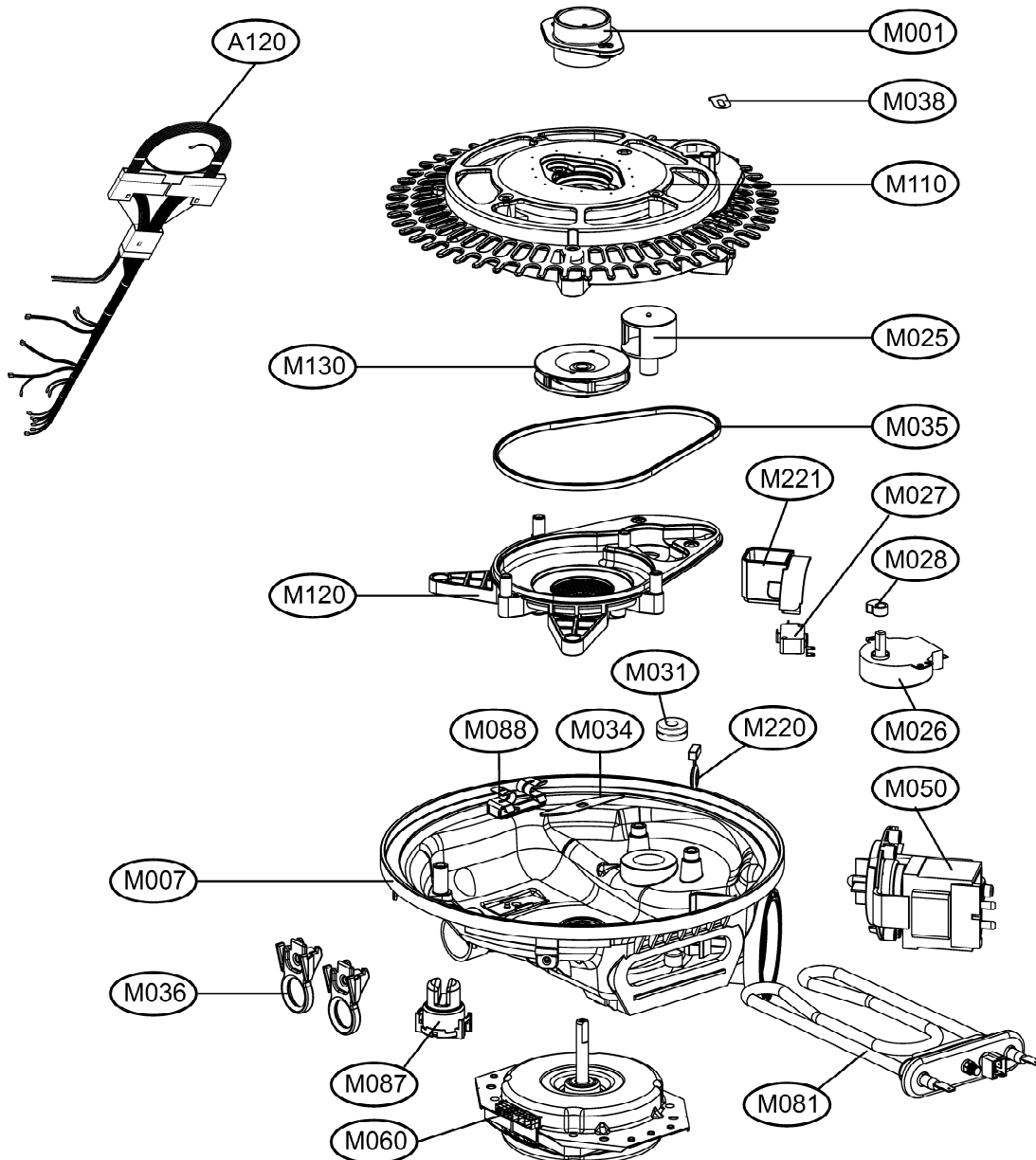

Serial No.	701 ~	
Rating Model	LDF7811XX/01 LDF7810XX/01 LDF6810XX/01 LDF6810XX/02 LDS5811XX/01 LDS5811XX/02	LDF8812XX LDF8812XX/01
P/No.	AJH31248604	AJH31248605



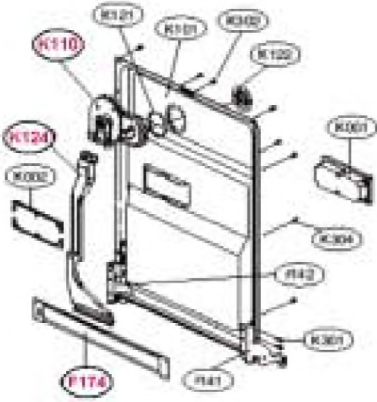
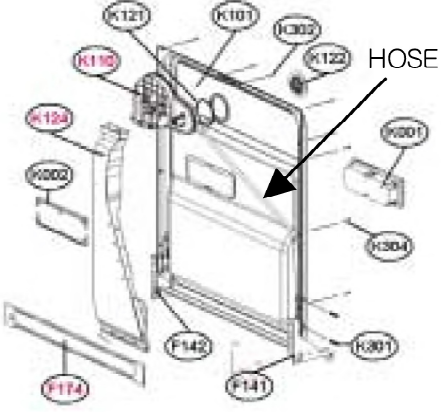
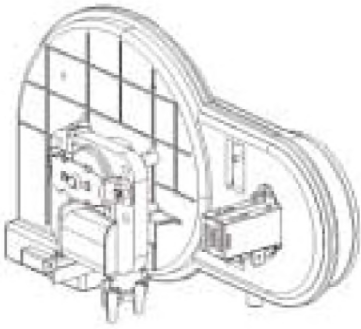
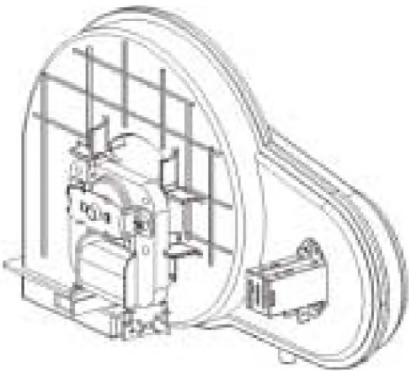

Appendix. A

CHANGED PART FROM DEC. 2007





	<p style="text-align: center;">BEFORE</p> <p style="text-align: center;">LDF7811XX / 01, LDF7810XX / 01 LDS5811XX / 01, LDF6810XX / 01 LDF8812ST</p>	<p style="text-align: center;">AFTER</p> <p style="text-align: center;">LDS5811XX / 02, LDF6810XX / 02 LDF8812ST / 01, LDF9810ST / 01</p>
<p>K100 DOORLINER ASSEMBLY</p> <p>*Casing ASM & Vent were changed to Improve Drying performance</p> <p>*Hose added</p>	<p>4937DD1001B</p> 	<p>4937DD1001C</p> 
<p>K110 CASING ASS SEMBLY</p> <p>*Casing ASM was changed to Improve Drying performance</p>	<p>5835ED2002D</p> 	<p>ABT35083801</p> 
<p>K124 VENT</p> <p>*Vent was changed to Improve Drying performance</p>	<p>MJZ36939301</p> 	<p>MJZ39902101</p> 

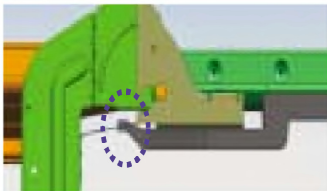

Appendix. B

B-1. Modified parts to improve drying performance.

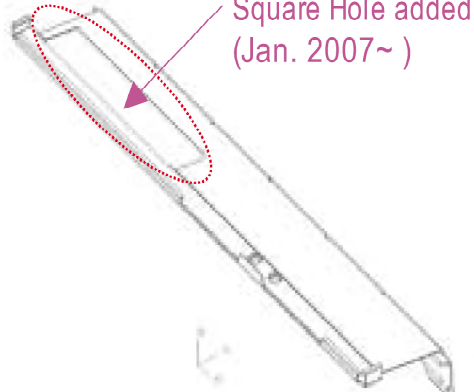
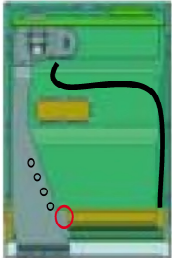
- Check original parts & replace (or modify) with new parts to improve drying performance.

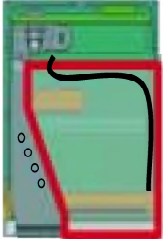
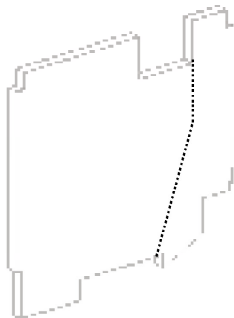
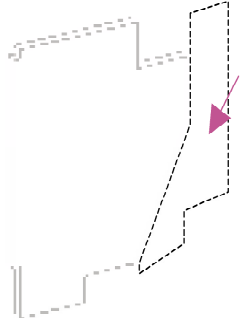

	BEFORE	AFTER
<p>F001 FRAME ASSEMBLY, LOWER</p> <p>*Frame was modified to avoid interference with new vent</p> 	<p>3211DD1001A</p> 	<p>3211DD1001A</p> <p>Square Hole added (Jan. 2007~)</p> 
<p>F174 HINGE BRACKET</p> <p>*Hinge bracket was modified to include a new vent mounting hole</p> 	<p>4810DD1001A</p> 	<p>4810DD1001A</p> <p>Hole added (Aug. 2007~)</p>  <p>* Drill a hole to fix new vent</p>
<p>FELT (In Frontcover)</p> <p>*Felt was modified to avoid interference with new vent</p> 	<p>4766DD1001B</p> 	<p>4766DD1001A</p> <p>Trim (Dec. 2007~)</p>  <p>* Cut the interference portion</p>



Appendix. B

B-2. Modified parts to improve drying performance.

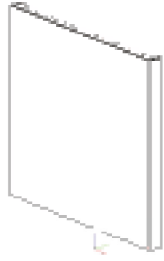
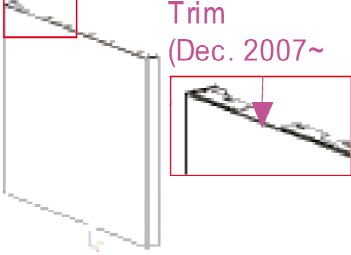
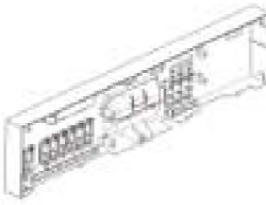
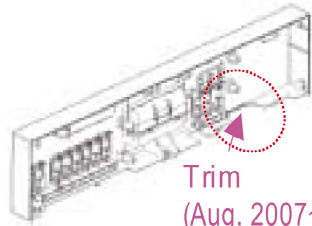
- Check original parts & replace (or modify) with new parts to improve drying performance.

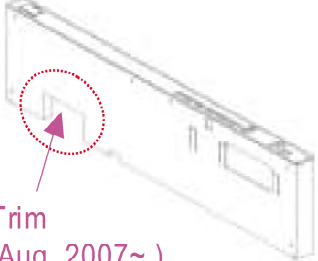
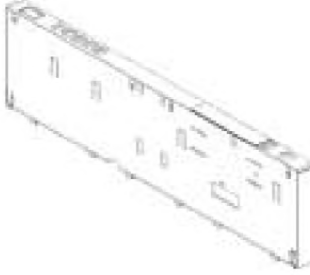
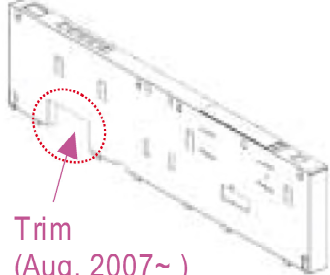
	Part Numbers		BEFORE	AFTER
K010 (LDS5811 Series Only) Front Cover *Front Cover was modified to avoid interference with new blower assembly 	W W	3550DD1004A		 <p>Trim (Dec. 2007~)</p>
	B B	3550DD1004B		
	S T	3550DD1004D		
<p>NOTE: It is not recommended to modify this part – replace part if installing new drying system on semi model.</p>				
K200 (LDS5811 Series ONLY) CONTROL PANEL ASSEMBLY *Control panel was modified to avoid interference with new blower assembly	W W	AGL32586501		 <p>Trim (Aug. 2007~)</p>
	B B	AGL32586502		
	S T	AGL32586503		
K200 (LDF8812ST ONLY) CONTROL PANEL ASSEMBLY *Control panel was modified to avoid interference with new blower assembly	AGL32598401			 <p>Trim (Aug. 2007~)</p>
K200 (LDF6810 Series ONLY) CONTROL PANEL ASSEMBLY *Control panel was modified to avoid interference with new blower assembly	W W	AGL32599305		 <p>Trim (Aug. 2007~)</p>
	B B	AGL32599306		
	S T	AGL32599304		



Appendix. C

※ If it is necessary to retrofit an earlier model with the new drying system, please follow the instructions below for modifying or replacing parts.

- 1) Remove front door panel & control panel.
- 2) Remove old blower & vent.
- 3) Cut the door liner white felt pad as shown*. Scissors work best for cutting the felt. (See Appendix C for part number if felt is to be replaced.)

*NOTE: The white felt can be marked with a felt pen using the new vent as a template.

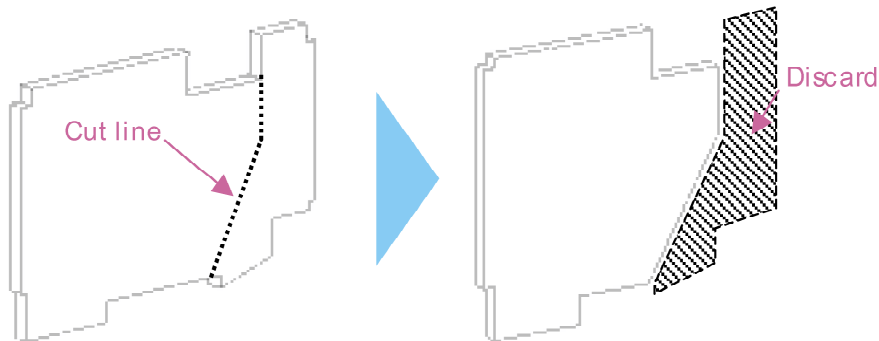

* Use scissors to remove the highlighted portion of the felt pad where it interferes with the vent as shown.

- 4) Assemble and mount the new blower & vent.
- 5) The control panel frame must be modified or replaced. If it is to be modified for blower clearance, cut out areas shown in the photos below*. Test fit panel to door liner prior to assembly to make sure panel does not touch blower motor or housing as this could cause excess noise.

*NOTE: It is not recommended to modify the semi-control panel or front door panel. Retrofit of the new drying system to LDS5811xx models should only be done by replacing the front door panel and control panel. (see Appendix C for parts)

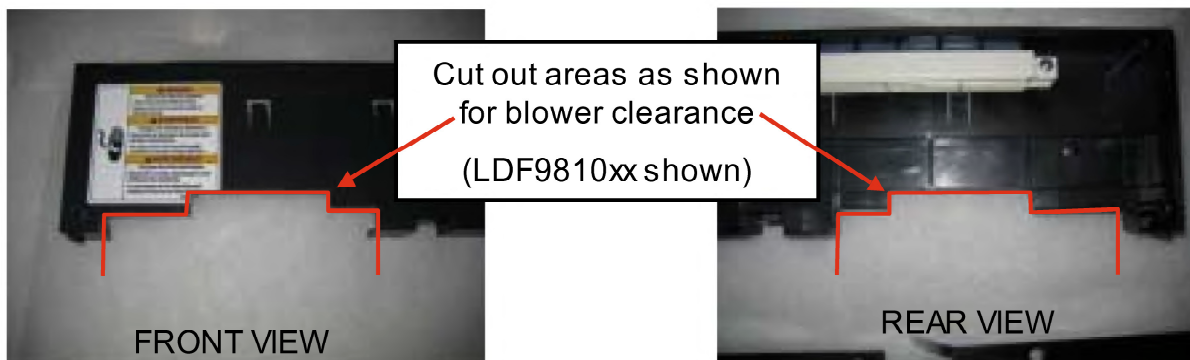



Appendix. C

※ Retrofit instructions continued

6) Using the new vent as a template, drill a new hole* for mounting the vent. Attach the vent using the black screw from the old vent. Align the bottom of the vent with the bottom of the door panel when assembling vent.

* NOTE: Be careful not to damage the door liner when drilling the hole.

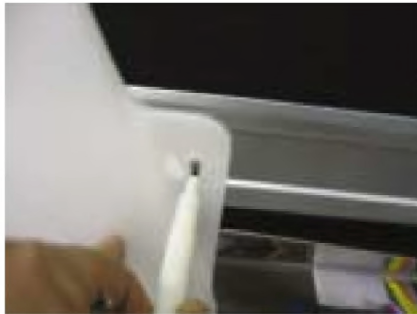

Mark the location to drill the hole. Make sure the bottom of the vent will align with the bottom of the front door panel.



Drill the pilot hole. Be careful not to damage the door liner when drilling the hole.



7) Attach one end of the rubber drain hose to the fitting on the bottom of the blower housing and secure with the clamp. Route the drain hose down the right side of the door behind the screw and foam so it can drain into the tub.

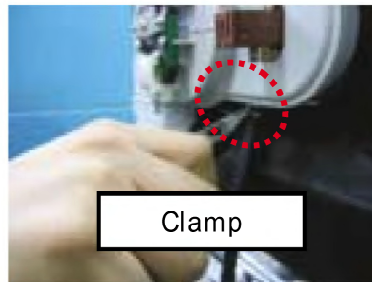
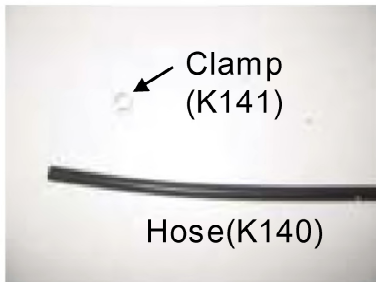

8) Secure the drain hose in position with the retaining wire at the dispenser or a piece of tape as needed.

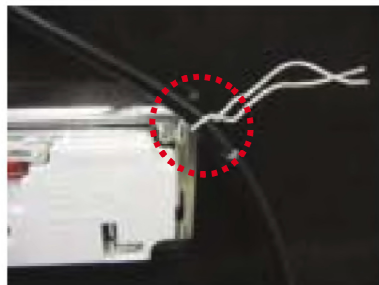

9) Reassemble control panel and front door panel. Test for proper operation.



MEMO



MEMO



P/No. : MFL37554801