



SERVICE MANUAL

MODEL: SJ5Y-S (SJ5Y-S, SPJ5B-W)

Wireless Sound Bar **SERVICE MANUAL**

MODEL: SJ5Y-S
(SJ5Y-S, SPJ5B-W)

CAUTION
BEFORE SERVICING THE UNIT, READ THE "SAFETY PRECAUTIONS"
IN THIS MANUAL.

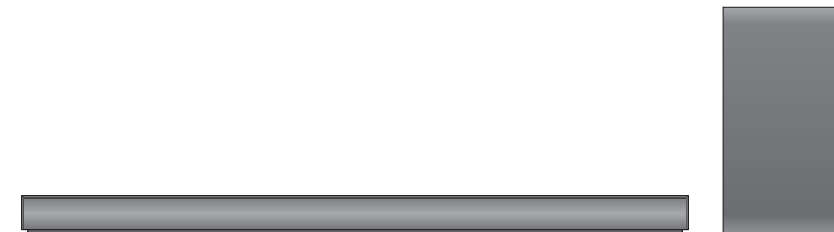

CONTENTS

SECTION 1 GENERAL

SECTION 2 CABINET & MAIN CHASSIS

SECTION 3 ELECTRICAL

SECTION 4 WIRELESS SUBWOOFER PART

SECTION 1 GENERAL

CONTENTS

ESD PRECAUTIONS	1-3
NAME OF EACH COMPONENT	1-4
WIRELESS SUBWOOFER CONNECTION.....	1-5
HIDDEN KEY MODE	1-6
SOFTWARE UPDATE GUIDE.....	1-7
SPECIFICATIONS	1-13

ESD PRECAUTIONS

Electrostatically Sensitive Devices (ESD)



Some semiconductor (solid state) devices can be damaged easily by static electricity. Such components commonly are called Electrostatically Sensitive Devices (ESD). Examples of typical ESD devices are integrated circuits and some field-effect transistors and semiconductor chip components. The following techniques should be used to help reduce the incidence of component damage caused by static electricity.

1. Immediately before handling any semiconductor component or semiconductor-equipped assembly, drain off any electrostatic charge on your body by touching a known earth ground. Alternatively, obtain and wear a commercially available discharging wrist strap device, which should be removed for potential shock reasons prior to applying power to the unit under test.
2. After removing an electrical assembly equipped with ESD devices, place the assembly on a conductive surface such as aluminum foil, to prevent electrostatic charge buildup or exposure of the assembly.
3. Use only a grounded-tip soldering iron to solder or unsolder ESD devices.
4. Use only an anti-static solder removal device. Some solder removal devices not classified as "anti-static" can generate electrical charges sufficient to damage ESD devices.
5. Do not use freon-propelled chemicals. These can generate electrical charges sufficient to damage ESD devices.
6. Do not remove a replacement ESD device from its protective package until immediately before you are ready to install it. (Most replacement ESD devices are packaged with leads electrically shorted together by conductive foam, aluminum foil or comparable conductive materials).
7. Immediately before removing the protective material from the leads of a replacement ESD device, touch the protective material to the chassis or circuit assembly into which the device will be installed.

CAUTION : BE SURE NO POWER IS APPLIED TO THE CHASSIS OR CIRCUIT, AND OBSERVE ALL OTHER SAFETY PRECAUTIONS.

8. Minimize bodily motions when handling unpackaged replacement ESD devices. (Otherwise harmless motion such as the brushing together of your clothes fabric or the lifting of your foot from a carpeted floor can generate static electricity sufficient to damage an ESD device).

CAUTION. GRAPHIC SYMBOLS

	THE LIGHTNING FLASH WITH APROWHEAD SYMBOL. WITHIN AN EQUILATERAL TRIANGLE, IS INTENDED TO ALERT THE SERVICE PERSONNEL TO THE PRESENCE OF UNINSULATED "DANGEROUS VOLTAGE" THAT MAY BE OF SUFFICIENT MAGNITUDE TO CONSTITUTE A RISK OF ELECTRIC SHOCK.
	THE EXCLAMATION POINT WITHIN AN EQUILATERAL TRIANGLE IS INTENDED TO ALERT THE SERVICE PERSONNEL TO THE PRESENCE OF IMPORTANT SAFETY INFORMATION IN SERVICE LITERATURE.

NAME OF EACH COMPONENT

• Front Panel

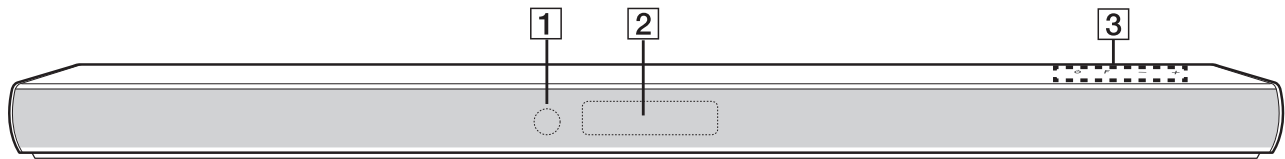

1 Remote sensor

2 Display window

3 The buttons are located on the rear.

• Rear Panel

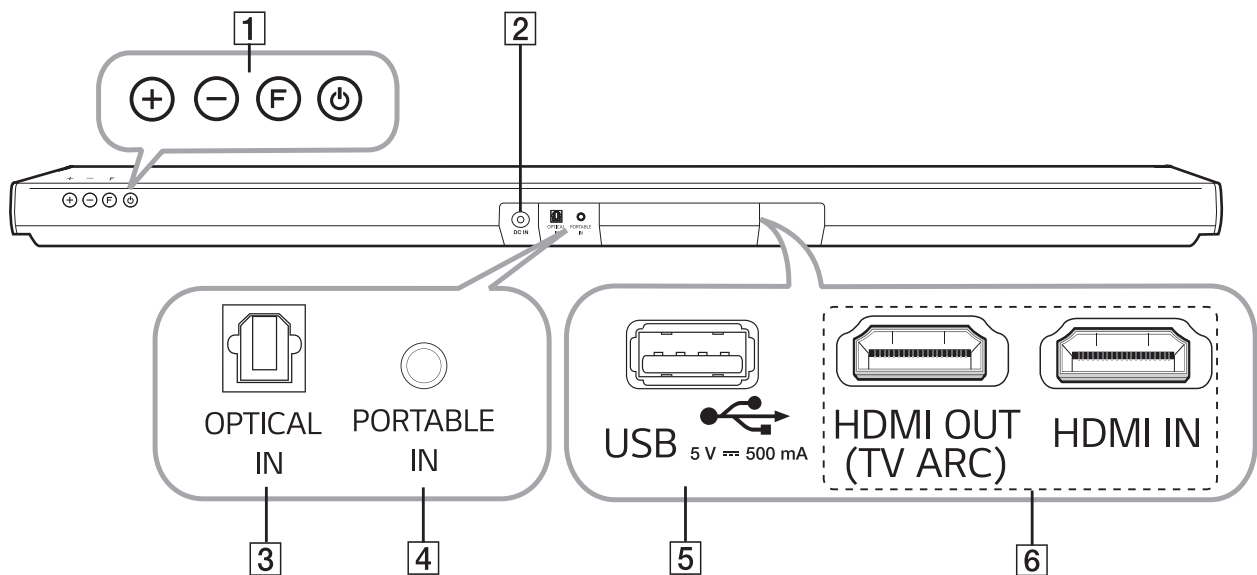

- 1** **+ / -**: (Volume) : Adjusts volume level
- F** (Function) : Selects the function and input source.
- ⏻** (Standby)

- 2** **DC IN** : AC adapter input
- 3** **OPTICAL IN** : Optical input
- 4** **PORTABLE IN** : Portable input
- 5** **USB** 
- 6** **HDMI OUT (TV ARC) / IN** : HDMI output / input

WIRELESS SUBWOOFER CONNECTION

LED indicator of wireless subwoofer

LED Color	Status
Green (Blink)	Attempting to make connection.
Green	The connection is completed.
Red	The wireless subwoofer is in standby mode or the connection is failed.
Off (No display)	The power cord of wireless subwoofer is disconnected.

Setting up the wireless subwoofer for the first time

1. Connect the power cord to the subwoofer and plug the power cord into a power outlet.
2. Turn on the main unit : The sound bar and wireless subwoofer will be **automatically** connected.
 - Green LED on the rear of wireless subwoofer turns on.

Manually pairing wireless subwoofer

When your connection is not completed, you can check red LED on the wireless subwoofer and the wireless subwoofer does not make sound. To solve the problem, follow the steps below.

1. Press **Pairing** button on the rear of the wireless subwoofer.

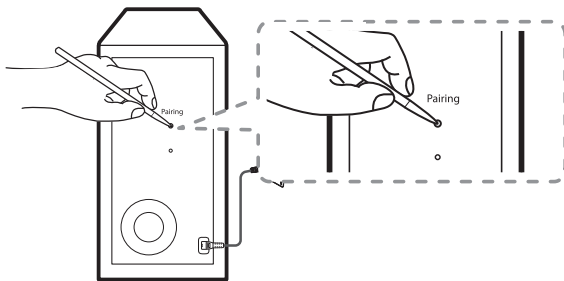

- The green LED on the rear of the wireless subwoofer blinks quickly.
2. Turn on the main unit.
 3. Pairing is completed.
 - The green LED on the rear of the wireless subwoofer turns on.

Note:

- It takes a few seconds (and may take longer) for the main unit and the subwoofer to communicate with each other and make sounds.
- The closer the main unit and the subwoofer, the better sound quality. It is recommended to install the main unit and the subwoofer as close as possible and avoid the cases below.
 - There is an obstacle between the main unit and the subwoofer.
 - There is a device using the same frequency as this wireless connection, such as medical equipment, a microwave, or a wireless LAN device.
 - Keep the sound bar and the subwoofer away from the device (ex. wireless router, microwave oven, etc.) over 1m to prevent wireless interference.

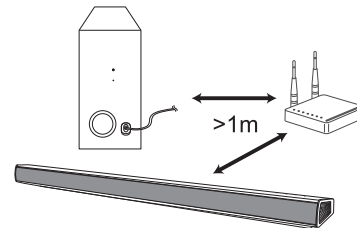

HIDDEN KEY MODE

HIDDEN MODE	KEYS
EEPROM CLEAR (Initialize)	Main unit '←(Volume)' + Remote control '*) UND EFFECT ' for more than 3 seconds. Display window : "E-CLR"
VERSION CHECK	Main unit '←(Volume)' + Remote control '▶▶(Play/Pause)' for more than 3 seconds. Next : Forward Skip / Previous : Backward Skip Exit : Power off

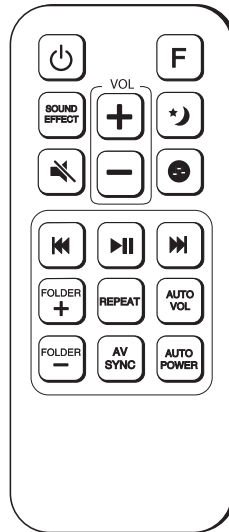

SOFTWARE UPDATE GUIDE

1. Using USB

1-1. Preparation

- Remote control.
- Do format USB Memory to FAT32 File system.
- USB : **Update file exist only in the USB Memory stick.**

Ex) SJ5 :

MAIN	⇒ E:\WSP_MAIN_SJ5.ROM (if USB driver is E:\₩)
MICOM	⇒ E:\WMICOM_SJ5.HEX (if USB driver is E:\₩)
BLUETOOTH	⇒ E:\WBT_SJ5.BIN (if USB driver is E:\₩)
MEQ	⇒ E:\WMEQ.BIN (if USB driver is E:\₩)
PEQ	⇒ E:\WEQ_PRG.BIN (if USB driver is E:\₩)
OPTION	⇒ E:\WOPT.BIN (if USB driver is E:\₩)
WIRELESS(TX)	⇒ E:\WWIRELESS_TX.bin (if USB driver is E:\₩)
WIRELESS(RX)	⇒ E:\WWIRELESS_RX.bin (if USB driver is E:\₩)

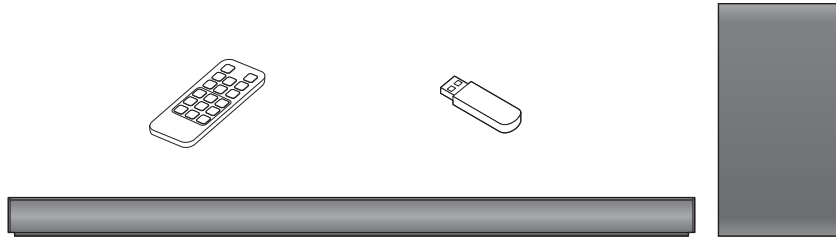

1-2. Update

- 1) Power on.
- 2) Select the USB function.
- 3) Insert USB.

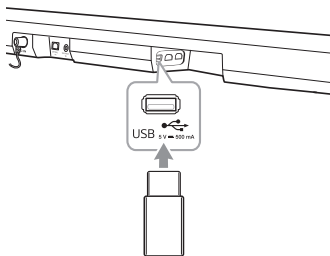

- 4) Never remove USB or AC cord while updating.
- 5) During the update, LCD is displayed as like below.



MAIN



Micom



Bluetooth



MEQ



PEQ



WIRELESS(TX)



WIRELESS(RX)

- 6) After update finish, power will be off automatically.

2. Using APP (FOTA : Firmware update Over The Air)

2-1. Run BT App (Music Flow Bluetooth)

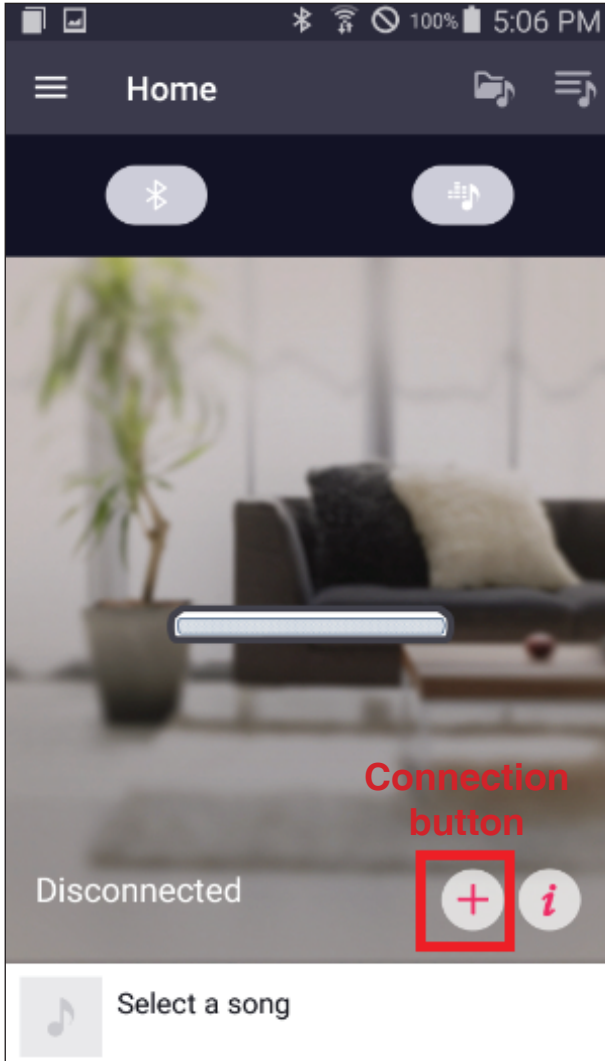

< Not Connected >

2-2. Connect Bluetooth

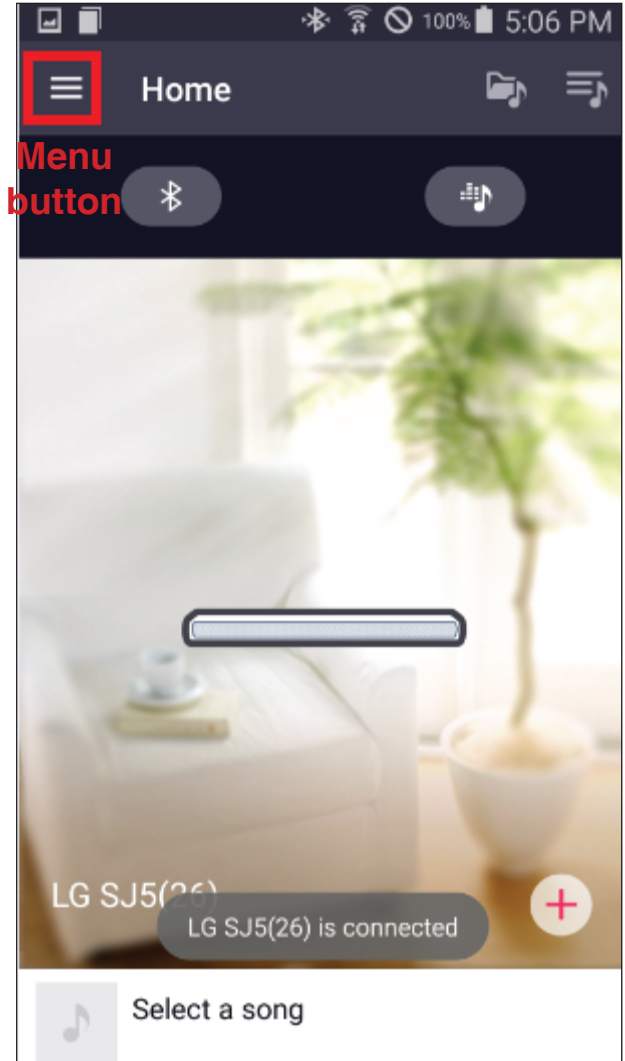

< Connected >

Using APP (FOTA : Firmware update Over The Air)

2-3. Setting Menu

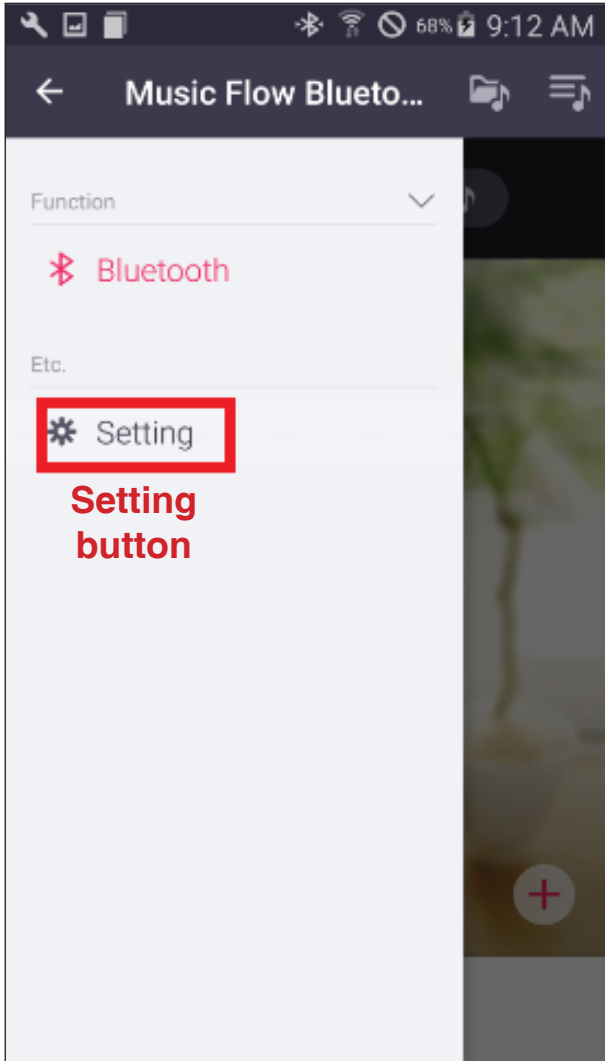

< Connected >

2-4-1. FOTA Start Button

(Phone should be available internet, Wi-Fi, LTE, 3G)

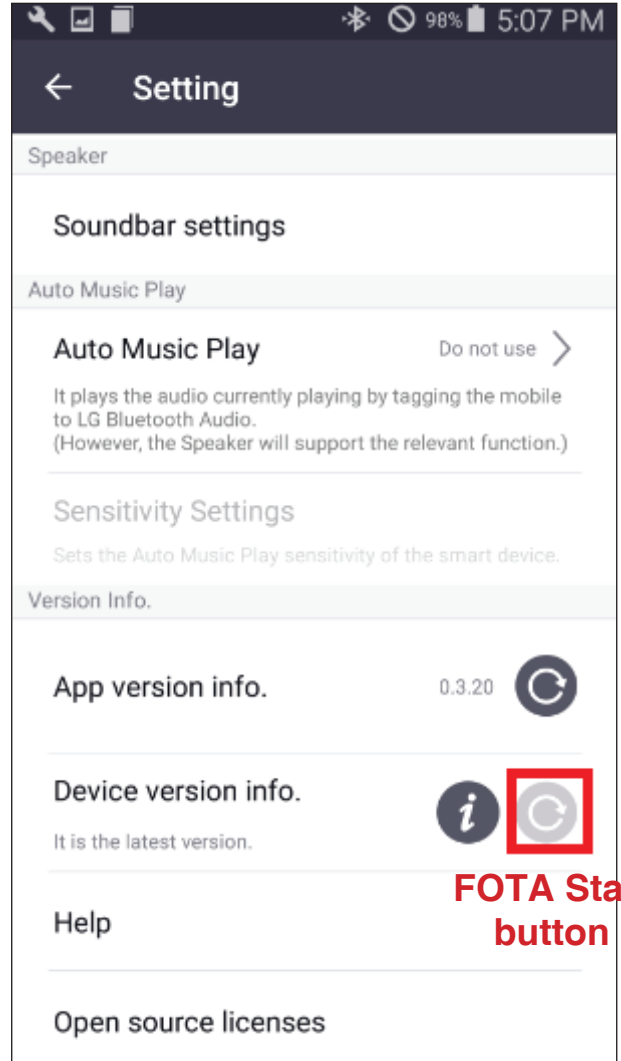

< Internet not Connected >

- Some Country(ex China) can not access to CDN Server. And can not use FOTA. So, This Button can not enable in that country.

Using APP (FOTA : Firmware update Over The Air)

2-4-2. FOTA Start Button

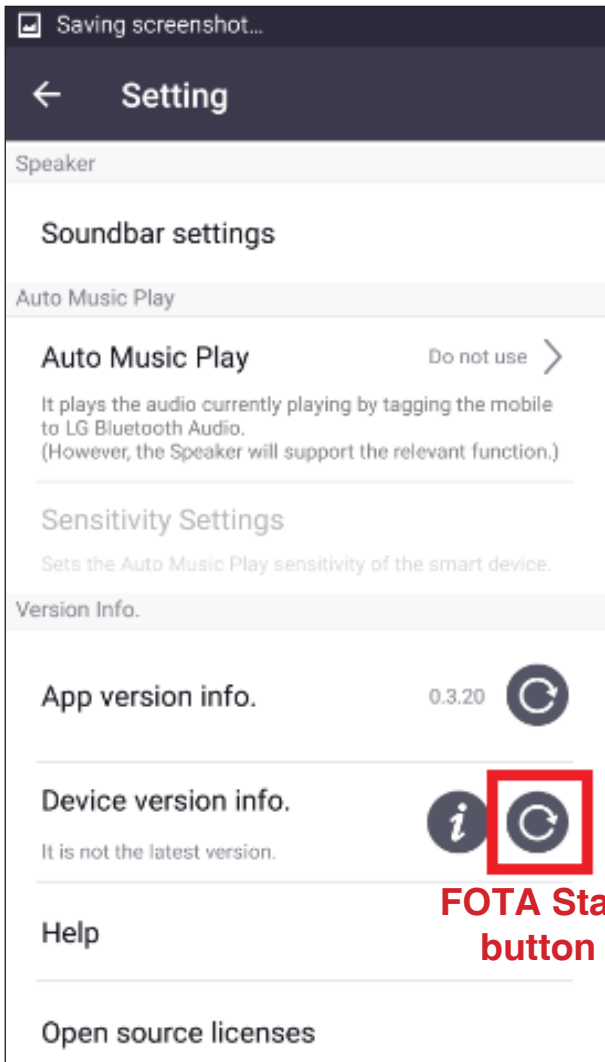

2-5. FOTA Caution

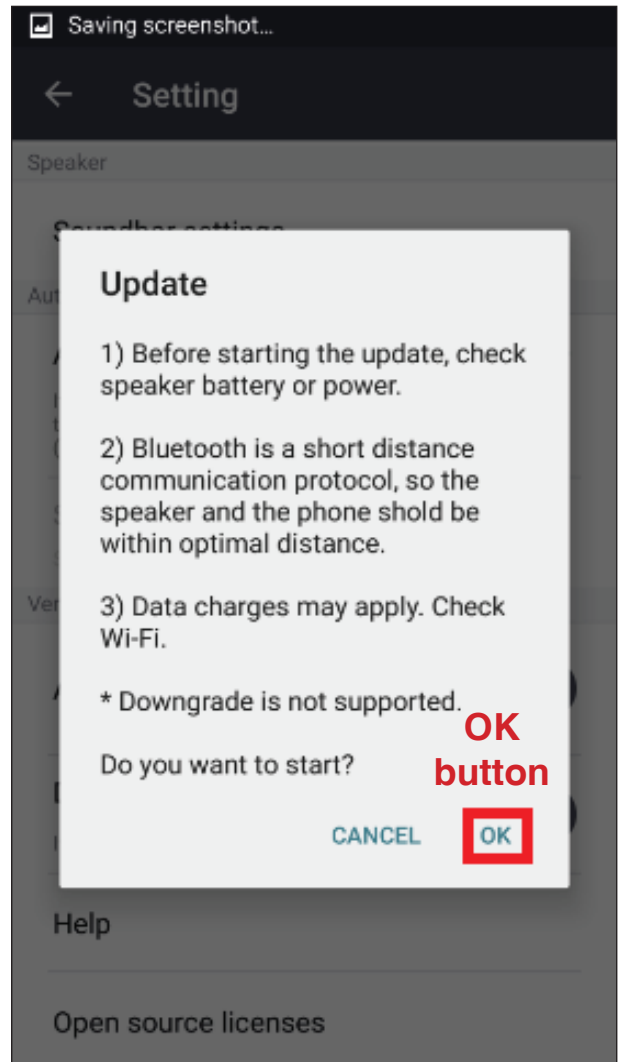

< Internet Connected >

Using APP (FOTA : Firmware update Over The Air)

2-6. FOTA - CDN Download

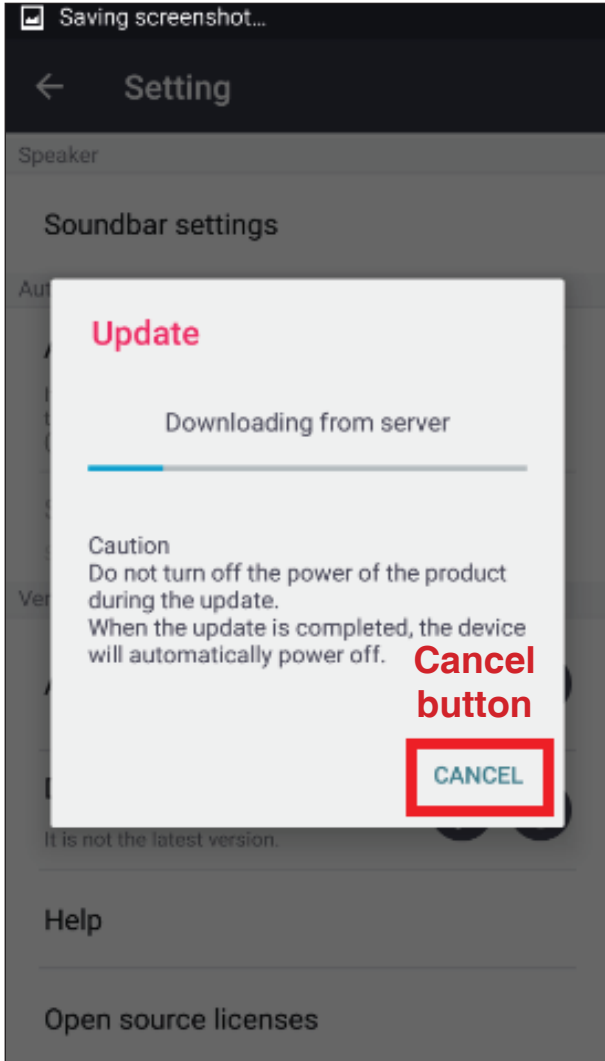

Cancel Button is available
When CDN downloading.

2-7. FOTA - OPP Download

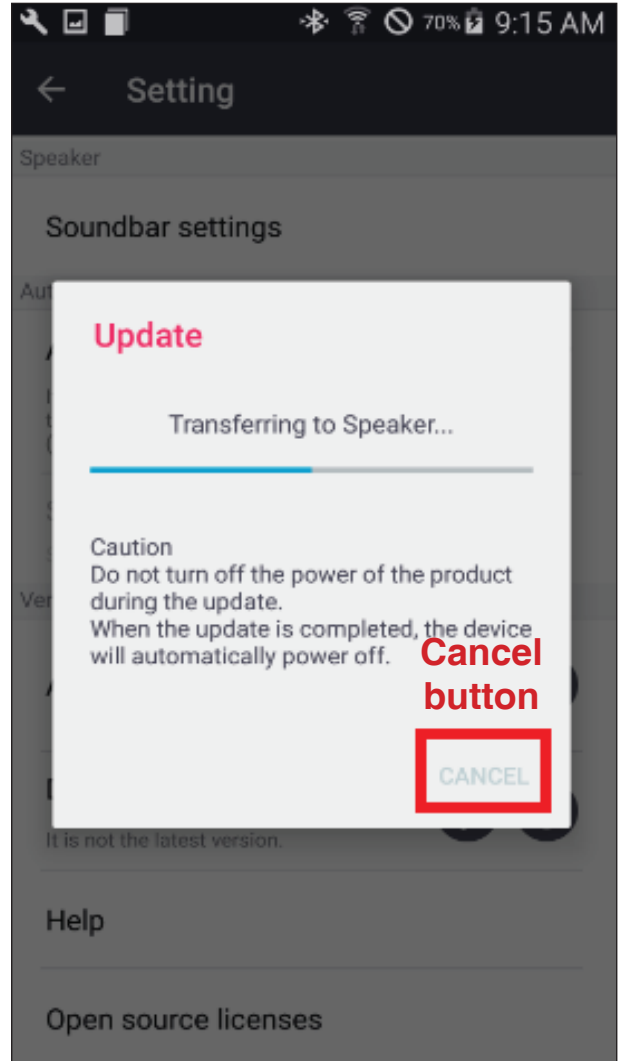

Cancel Button is not available
When OPP downloading.

Using APP (FOTA : Firmware update Over The Air)

2-8. FOTA - Write Flash

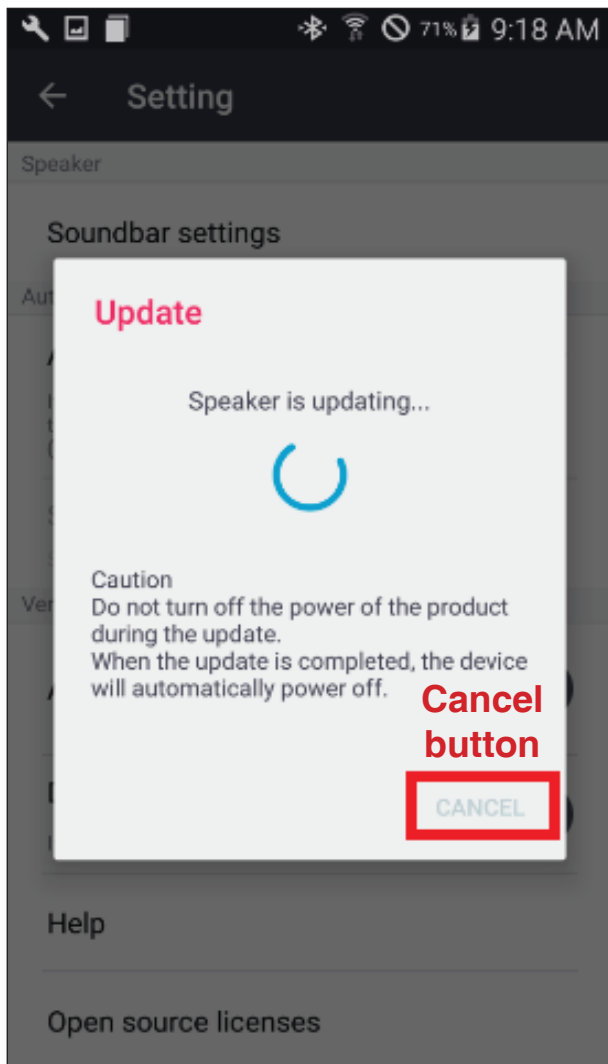

Cancel Button is not available
When Flash writing.

2-9. FOTA - Finish

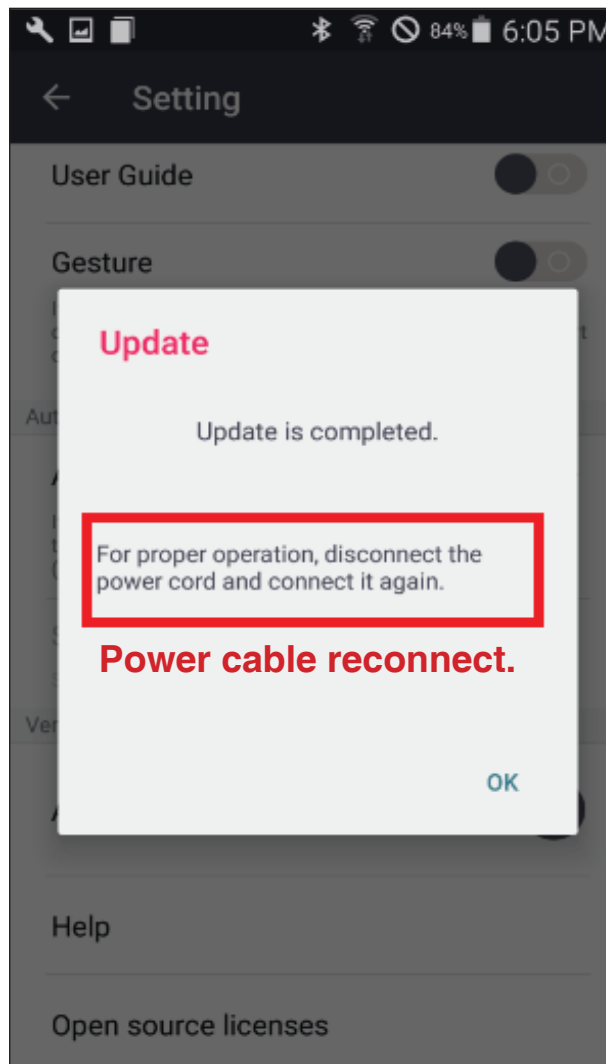

SPECIFICATIONS

• GENERAL

Power consumption	Refer to the main label. Networked standby : 0.5 W (If all network ports are activated.)
AC adapter	Model : DA-38A25 Manufacturer : Asian Power Devices Inc. Input : 100 - 240 V ~ 50 - 60 Hz 1.2 A Output : 25 V \approx 1.52 A
Dimensions (W x H x D)	Approx. 950 mm x 55 mm x 85 mm With foot
Operating temperature	5 °C to 35 °C
Operating humidity	5 % to 90 %
Bus Power Supply	5 V \approx 500 mA
Available Digital Audio In Sampling Frequency	32 kHz, 44.1 kHz, 48 kHz, 88.2 kHz, 96 kHz
Available Digital Audio In format	Dolby Audio, DTS Digital Surround, PCM

• INPUT/OUTPUT

OPTICAL IN (Digital audio in)	3 V (p-p), Optical jack x 1
PORTABLE IN (Portable in)	0.5 Vrms (3.5 mm stereo jack) x 1
HDMI IN	19 Pin (Type A, HDMI™ connector) x 1
HDMI OUT	19 Pin (Type A, HDMI™ connector) x 1

• AMPLIFIER (RMS OUTPUT)

Total	320 W RMS
Front	60 W RMS x 2 (4 Ω at 1 kHz, THD 10%)
Subwoofer	200 W RMS (3 Ω at 80 Hz, THD 10%)

• WIRELESS SUBWOOFER

Power requirements	Refer to the main label on the wireless subwoofer.
Power consumption	Refer to the main label on the wireless subwoofer.
Type	1 Way 1 Speaker
Impedance	3 Ω
Rated Input Power	200 W RMS
Max. Input Power	400 W RMS
Dimensions (W x H x D)	Approx. 171 mm x 320 mm x 252 mm

- Designs and specifications are subject to change without prior notice.

MEMO

A series of horizontal dotted lines for writing.

SECTION 2

CABINET & MAIN CHASSIS

CONTENTS

DISASSEMBLY INSTRUCTIONS	2-2
1. HOW TO DISASSEMBLE THE MAIN UNIT	2-2
2. HOW TO DISASSEMBLE THE SUBWOOFER	2-8
EXPLODED VIEWS	2-11
1. MAIN UNIT SECTION	2-11
2. WIRELESS SUBWOOFER SECTION	2-13
3. PACKING ACCESSORY SECTION	2-15

DISASSEMBLY INSTRUCTIONS

1. HOW TO DISASSEMBLE THE MAIN UNIT

※ Before begin, position the Main Unit upside down.

1-1. Case Bottom Assembly

- 1) Remove the 21 screws.
- 2) Remove the Case Bottom Assembly.

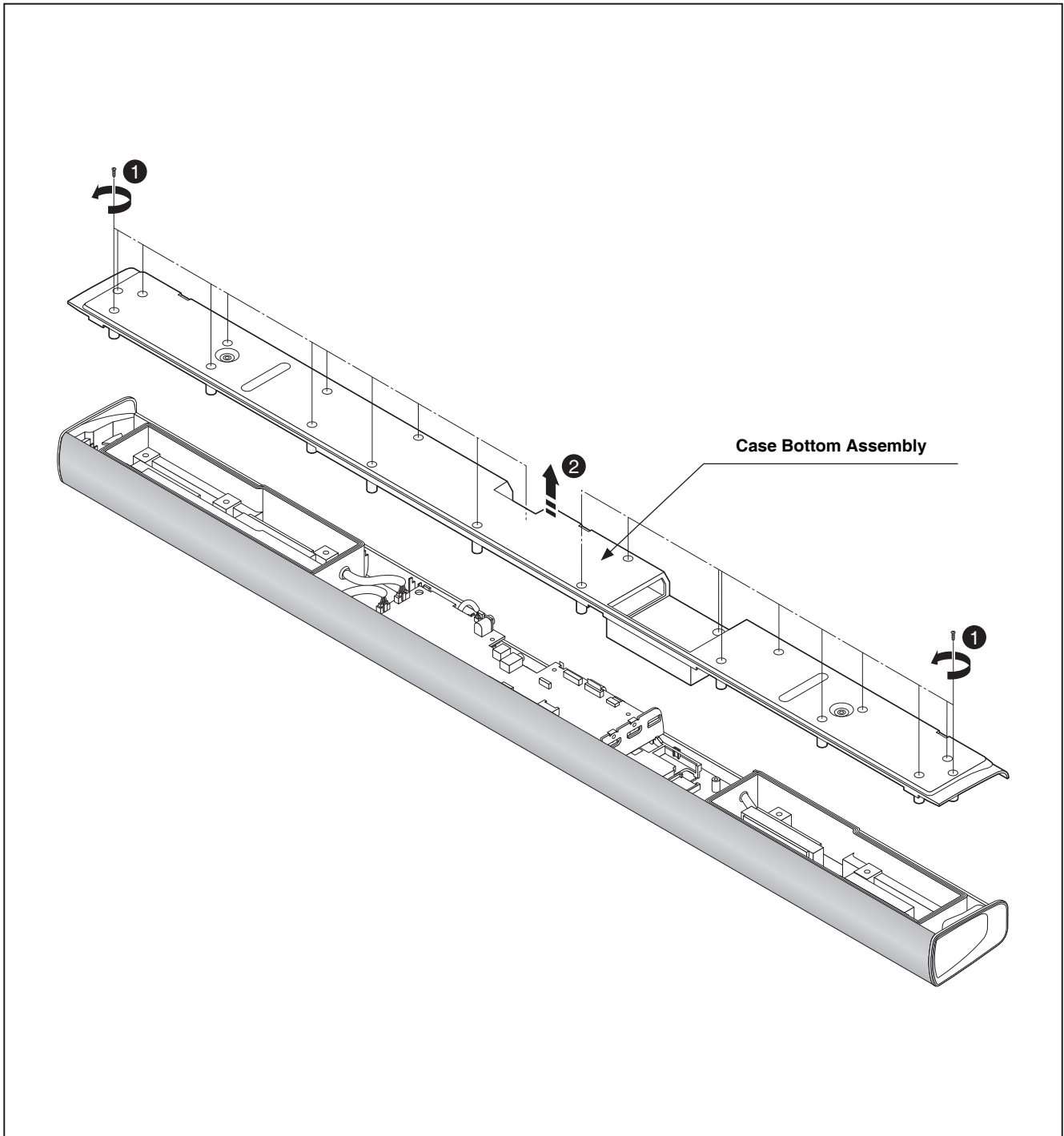

Figure 1-1

HOW TO DISASSEMBLE THE MAIN UNIT

1-2. Main Frame Assembly

1) Disconnect the 3 harness cables from the Main PCB Assembly.

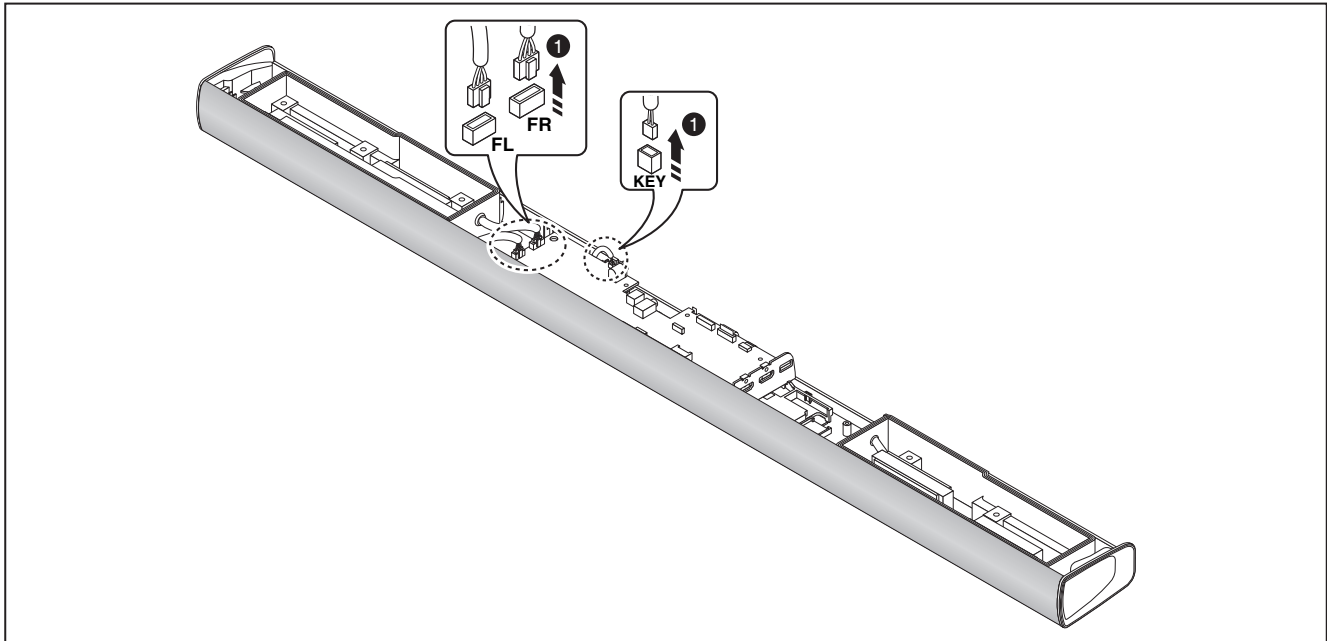

Figure 1-2 (1)

2) Remove the screw.

3) Remove the Main Frame Assembly (Main Chassis + PCBA).

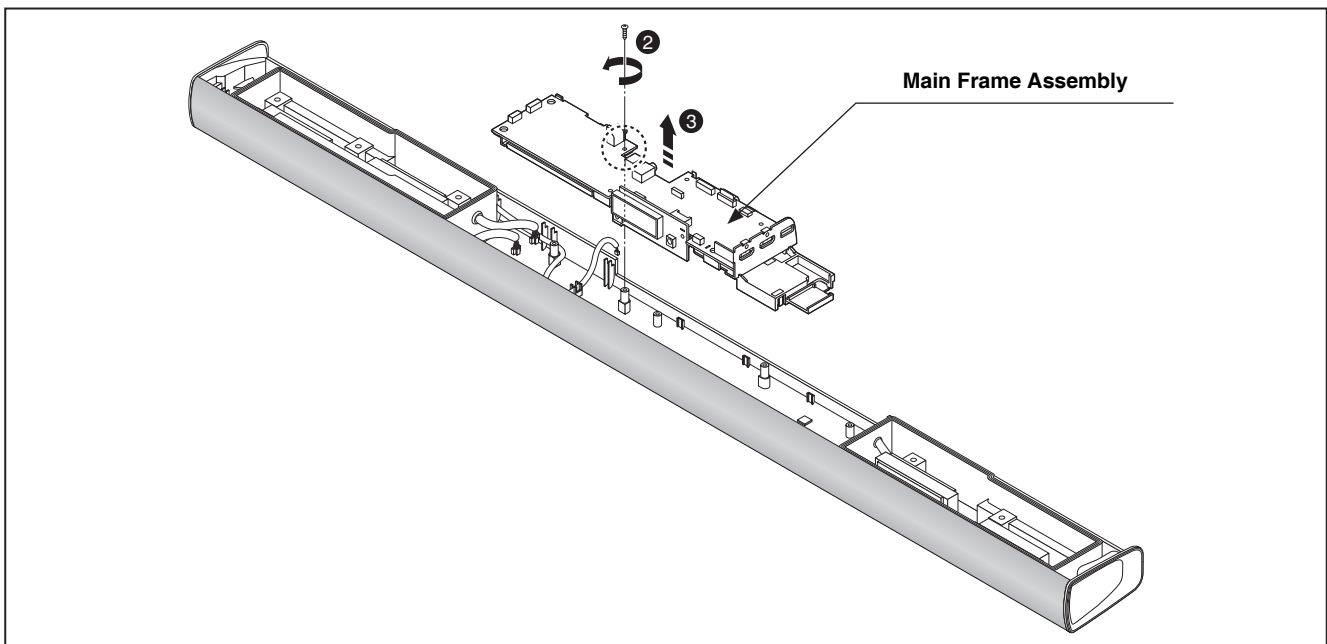

Figure 1-2 (2)

HOW TO DISASSEMBLE THE MAIN UNIT

1-2-1. Front PCB Assembly

- 1) Remove the 2 screws.
- 2) Remove the Front PCB Assembly.

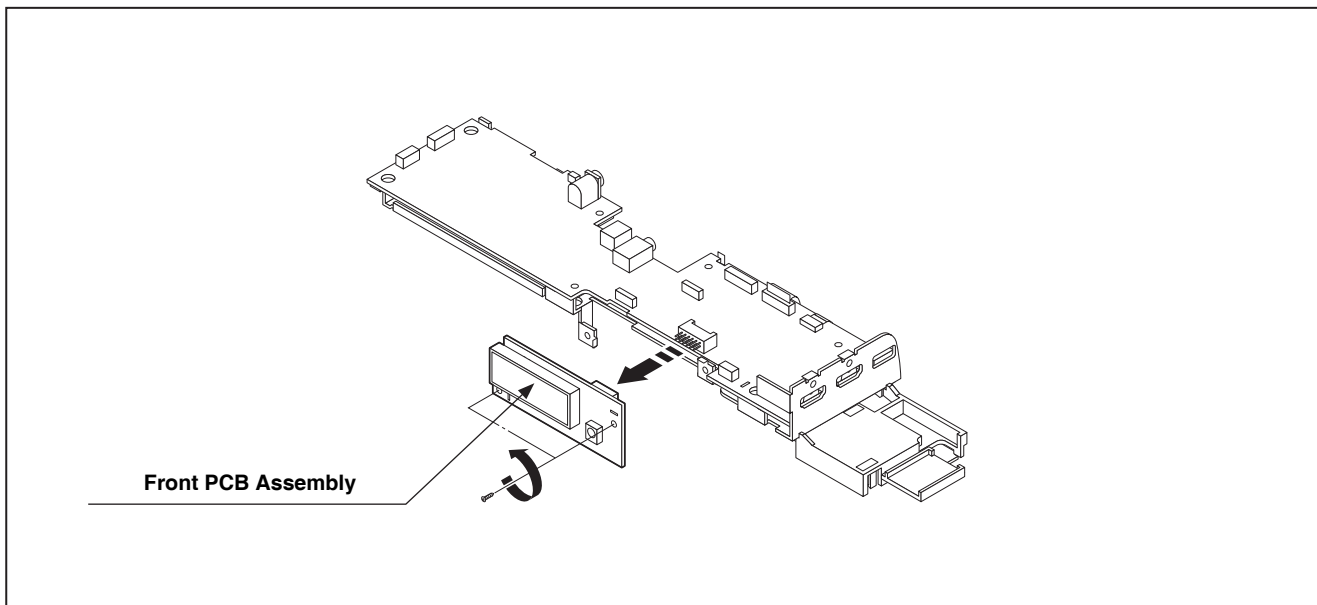

Figure 1-2-1

1-2-2. Main PCB Assembly

- 1) Detach the cables from the Main chassis.
- 2) Disconnect the FFC cables from the Main PCB Assembly.
- 3) Remove the 3 screws (Main + HDMI Jack).
- 4) Remove the Main PCB Assembly.

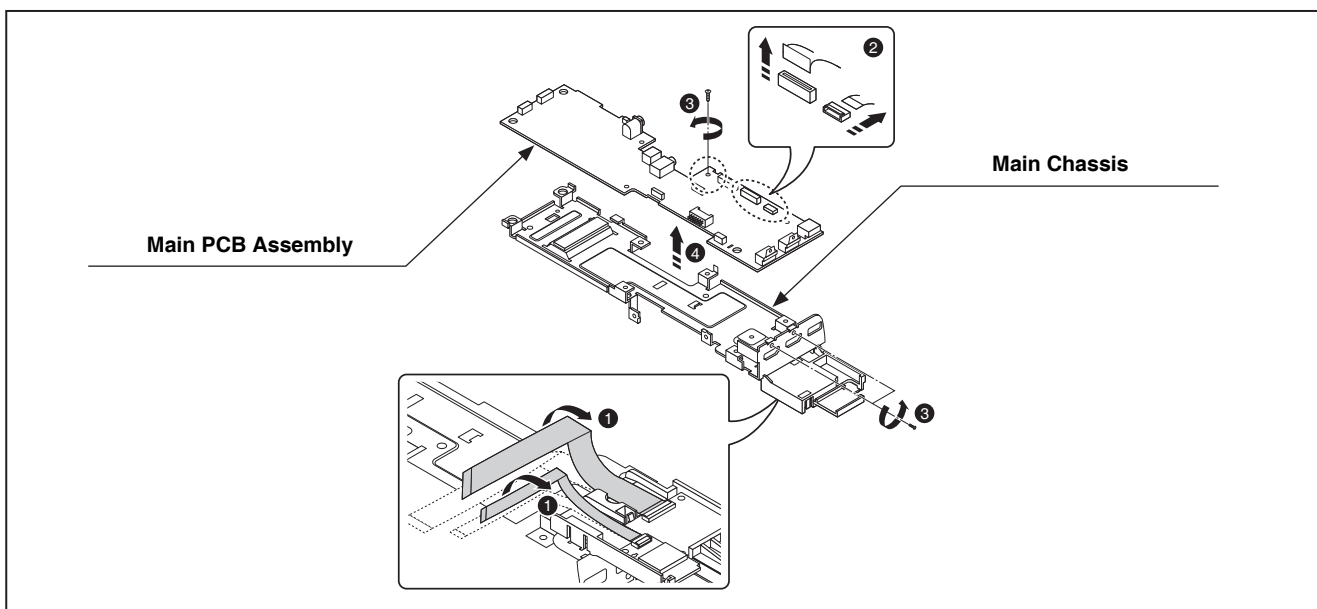

Figure 1-2-2

HOW TO DISASSEMBLE THE MAIN UNIT

1-2-3. BT and WIRELESS Module

- 1) Disconnect the FFC cable from the BT module.
- 2) Remove the BT module.
- 3) Disconnect the FFC cable from the WIRELESS module.
- 4) Disconnect the 2 Hooks.
- 5) Remove the WIRELESS module.

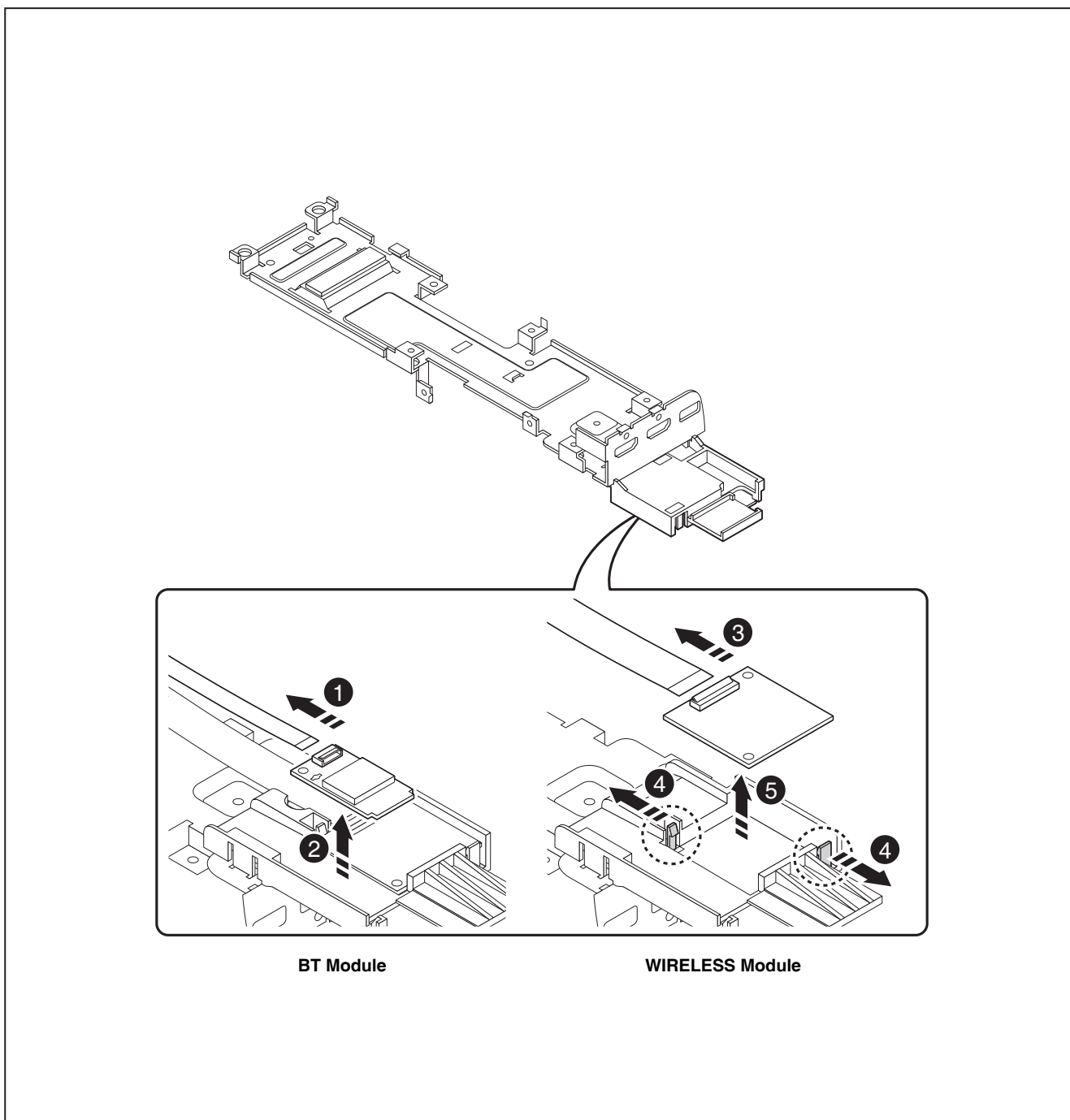

Figure 1-2-3

HOW TO DISASSEMBLE THE MAIN UNIT

1-3. SPEAKER CHAMBER L/R Assembly

1) Remove the Speaker Chamber L/R Assembly.

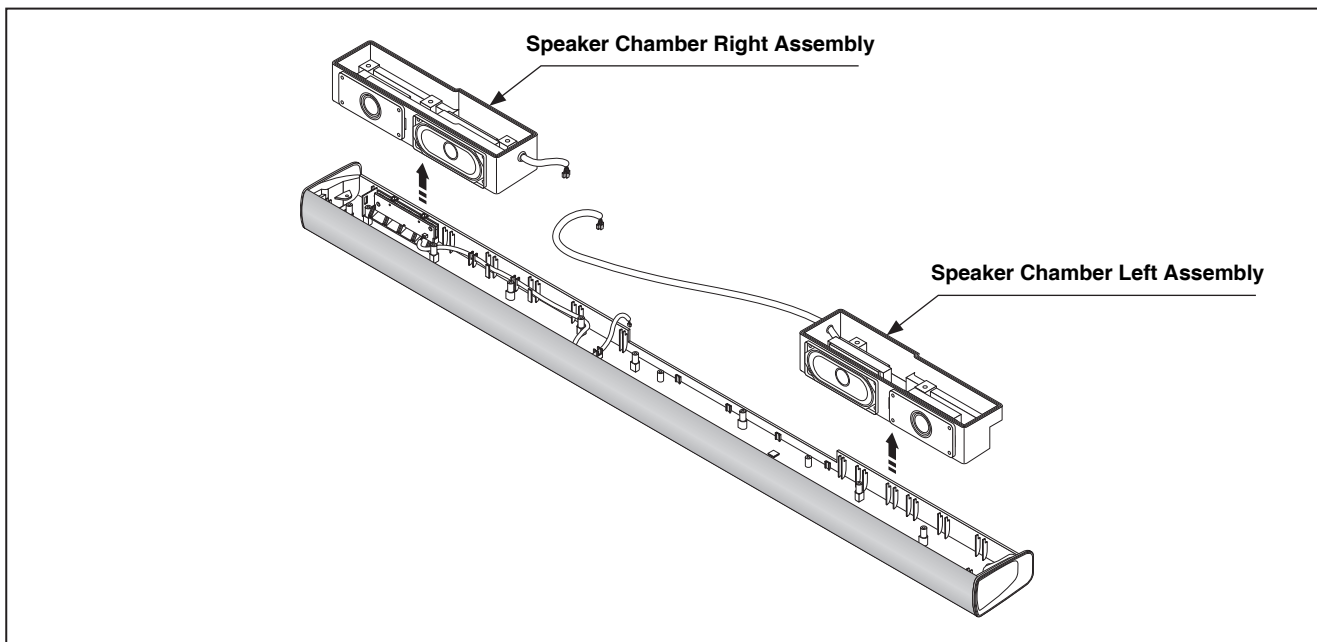

Figure 1-3

1-4. KEY PCB Assembly

1) Remove the KEY PCB Assembly.

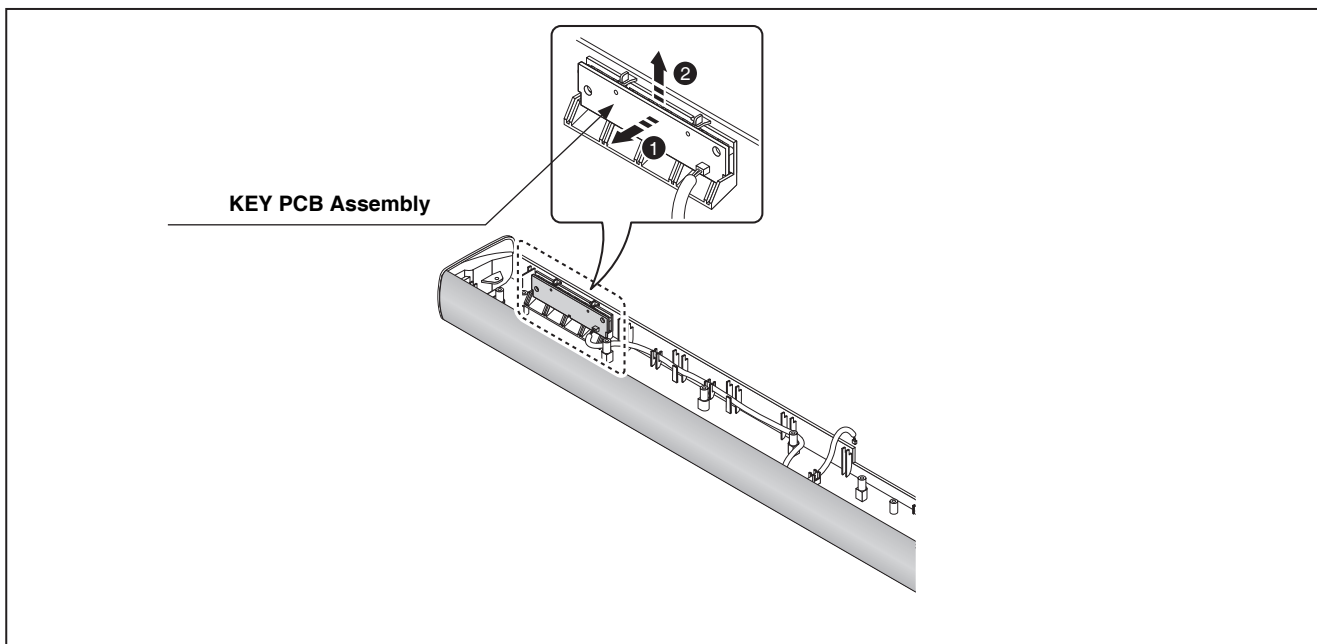

Figure 1-4

HOW TO DISASSEMBLE THE MAIN UNIT

1-5. How to organize cables

When assembling, place the cables (Speaker network cables and Key cable) as shown in the figure below.

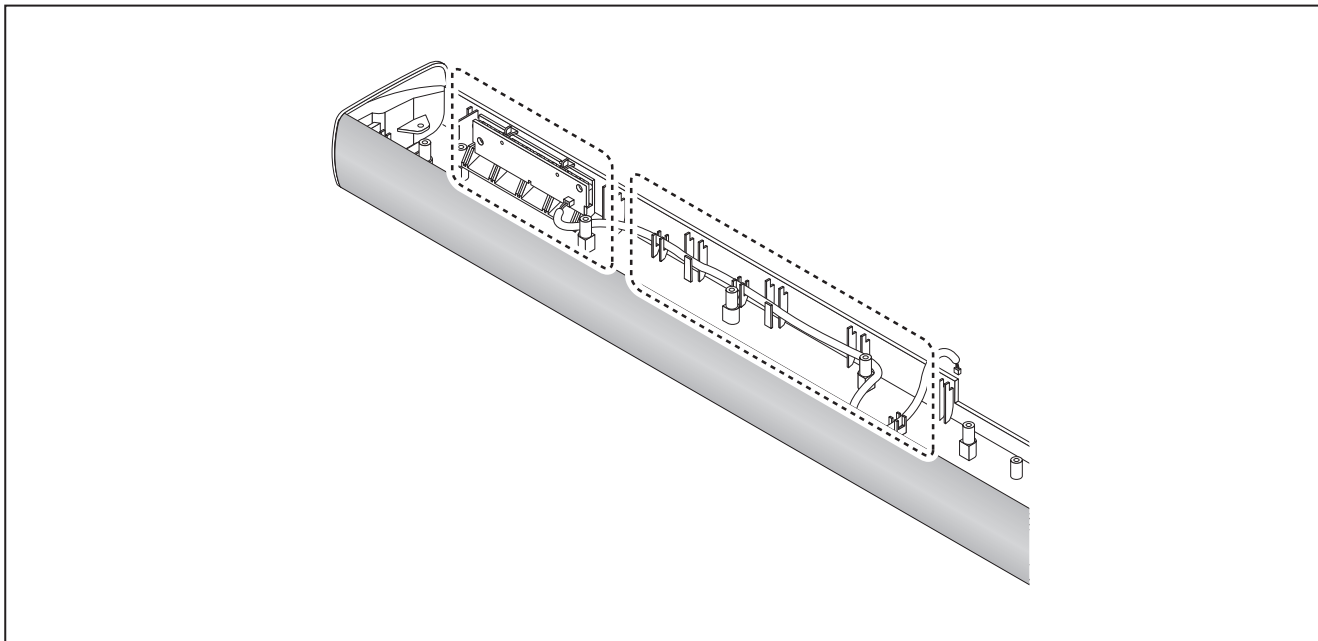

Figure 1-5 (1). < Harness cable from KEY PCB to MAIN PCB >

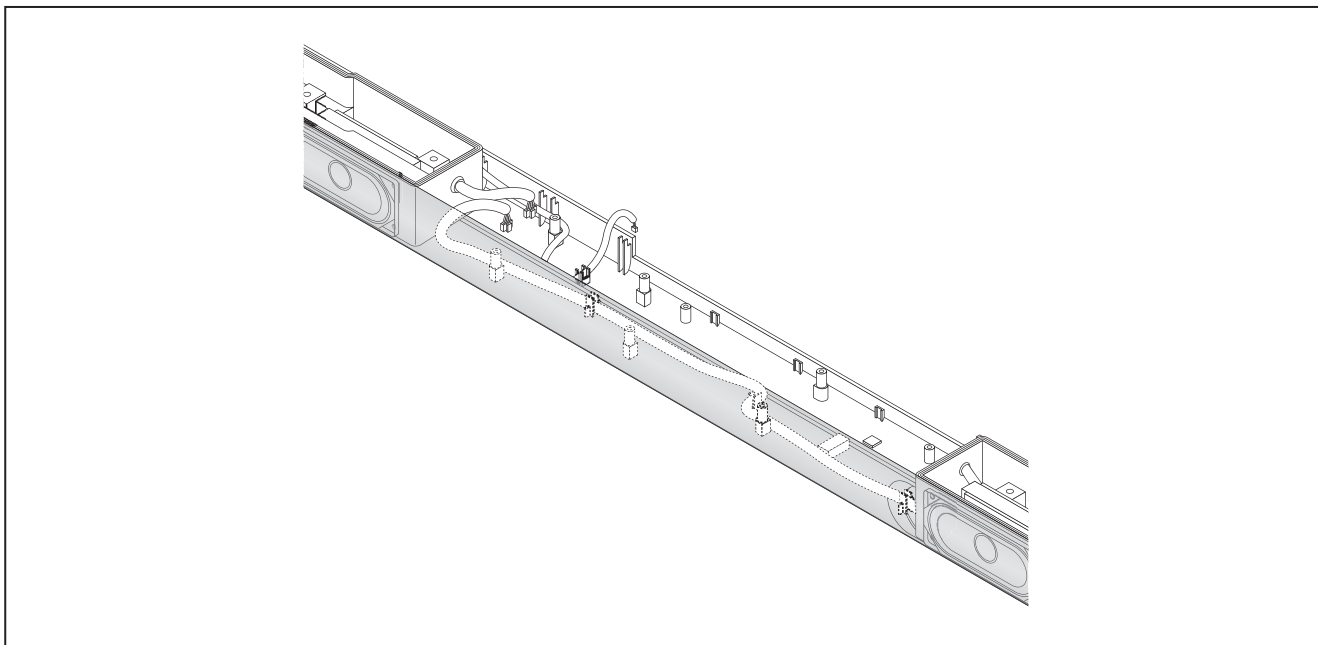

Figure 1-5 (2). < Speaker network cable from SPK Chamber L/R Assembly to MAIN PCB >

2. HOW TO DISASSEMBLE THE SUBWOOFER

2-1. Rear Panel Assembly

1) Remove the 13 screws.

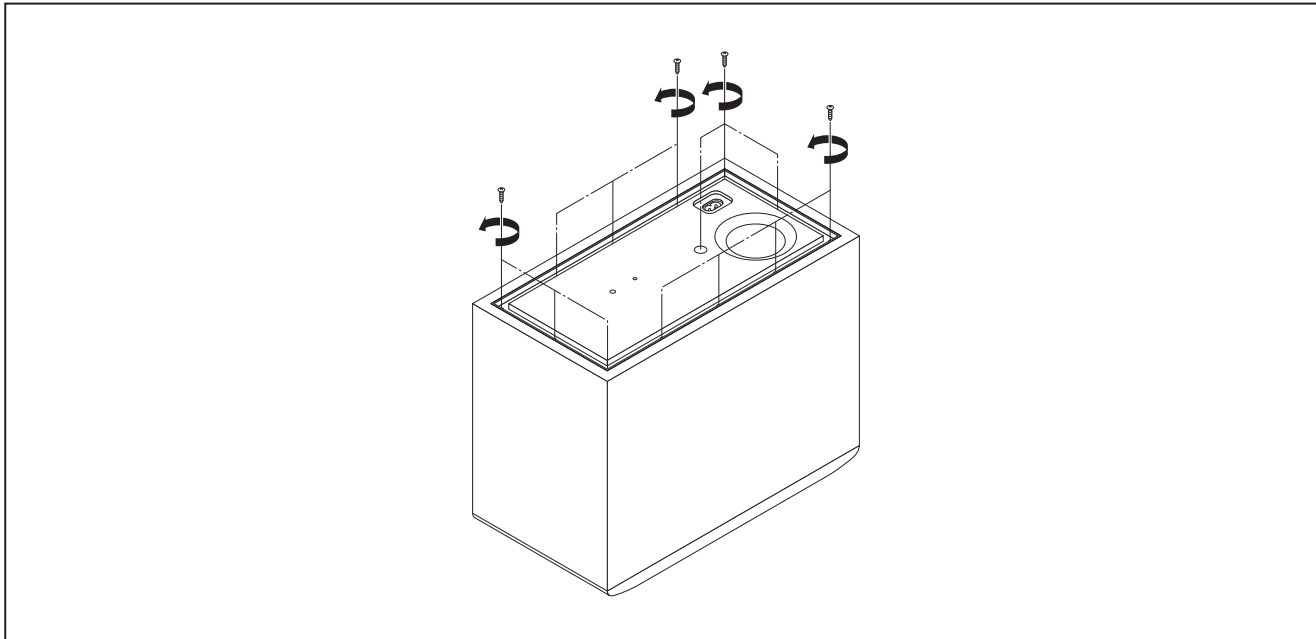

Figure 2-1 (1)

2) Pull out the Rear Panel Assembly and disconnect the SPK cable.

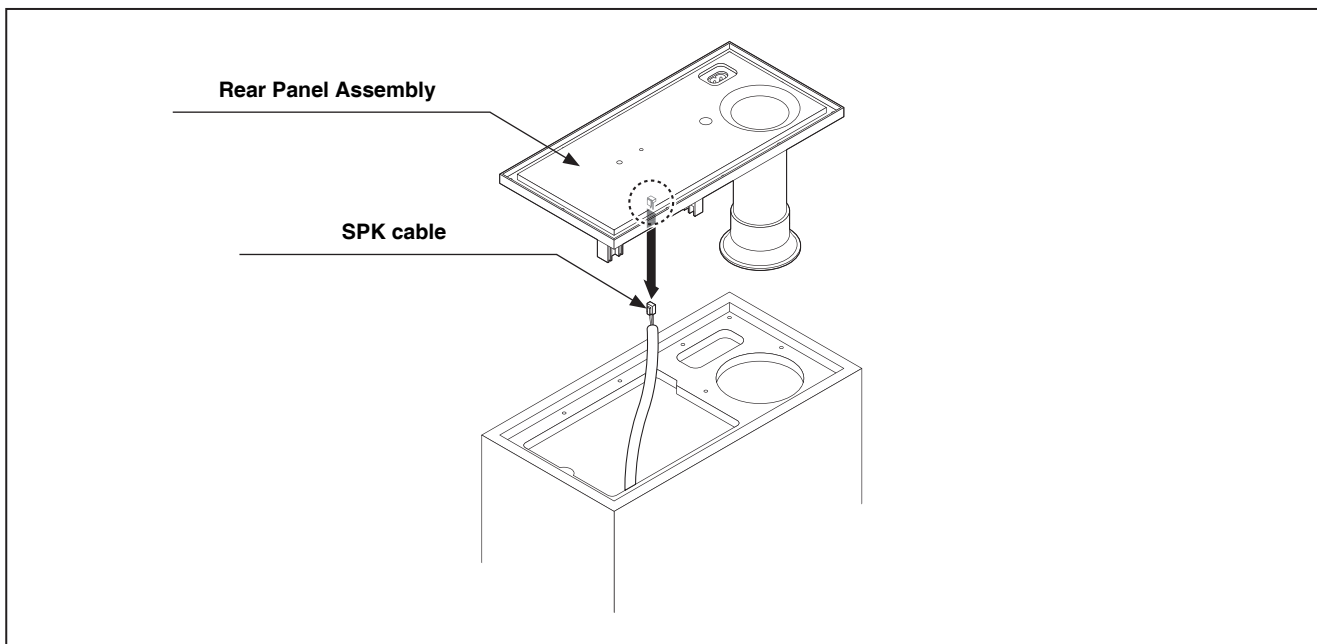

Figure 2-1 (2)

HOW TO DISASSEMBLE THE SUBWOOFER

2-2. WIRELESS Module

- 1) Disconnect the FFC cable.
- 2) Remove the EVA sheet (0.15T) covered the WIRELESS module.
- 3) Remove the WIRELESS module.
- 4) Remove the EVA gasket (1.0T) covered the WIRELESS module.

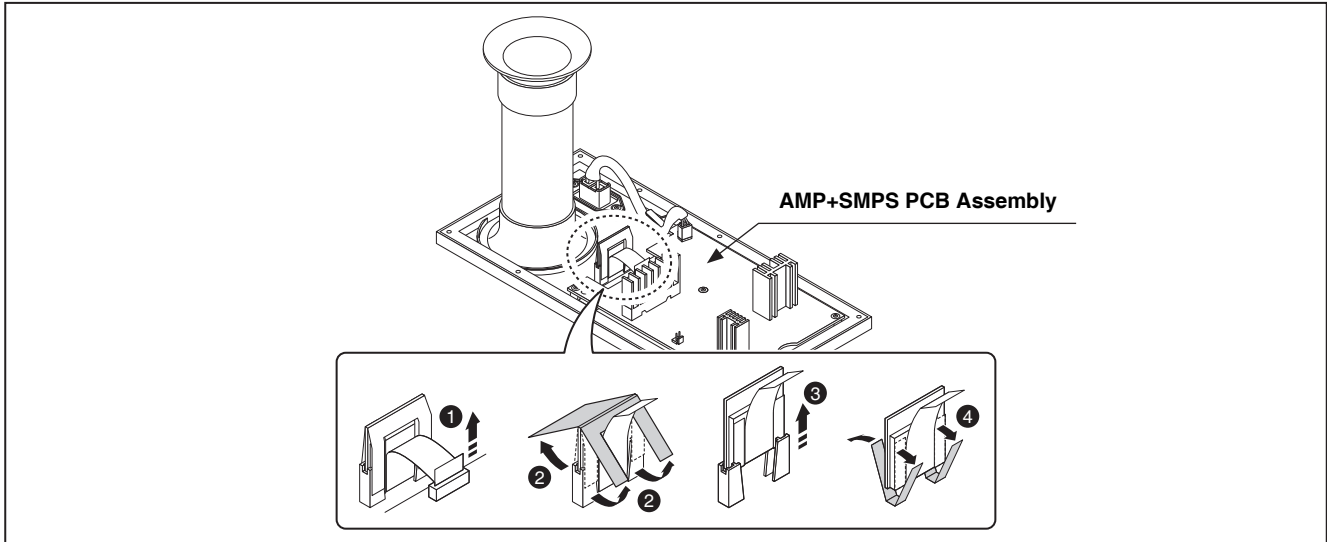

Figure 2-2 (1)

⚠ Caution when assembling the WIRELESS Module

- 1) Attach the EVA gaskets (1.0T) to both sides of the WIRELESS module.
- 2) Assemble the WIRELESS module into the wireless holder.
- 3) Attach the EVA sheet (0.15T) to the WIRELESS module.
- 4) Connect the FFC cable.

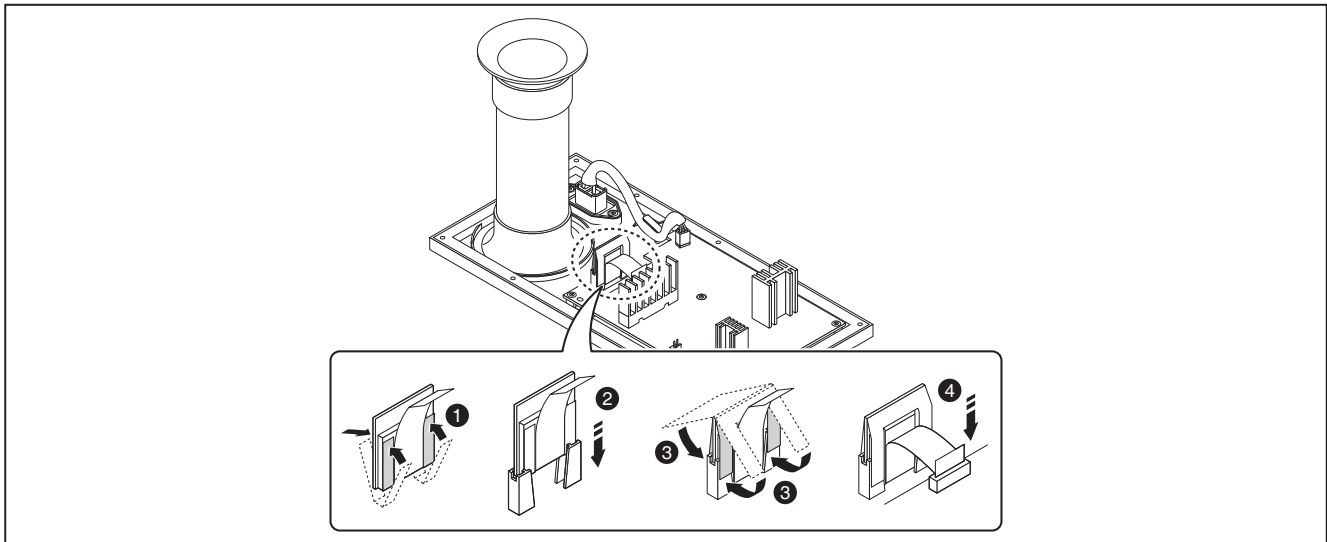

Figure 2-2 (2)

HOW TO DISASSEMBLE THE SUBWOOFER

2-3. AMP+SMPS PCB Assembly

- 1) Disconnect the Power inlet socket cable.

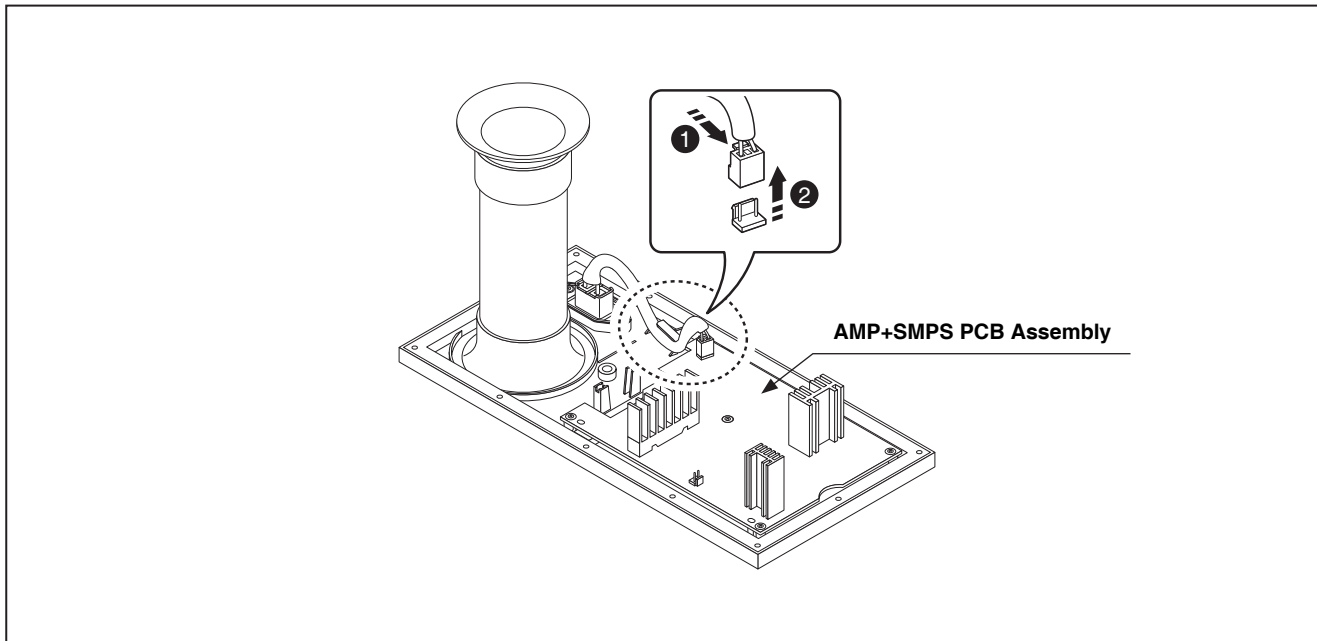

Figure 2-3 (1)

- 2) Remove the 5 screws.
- 3) Remove the AMP+SMPS PCB Assembly.

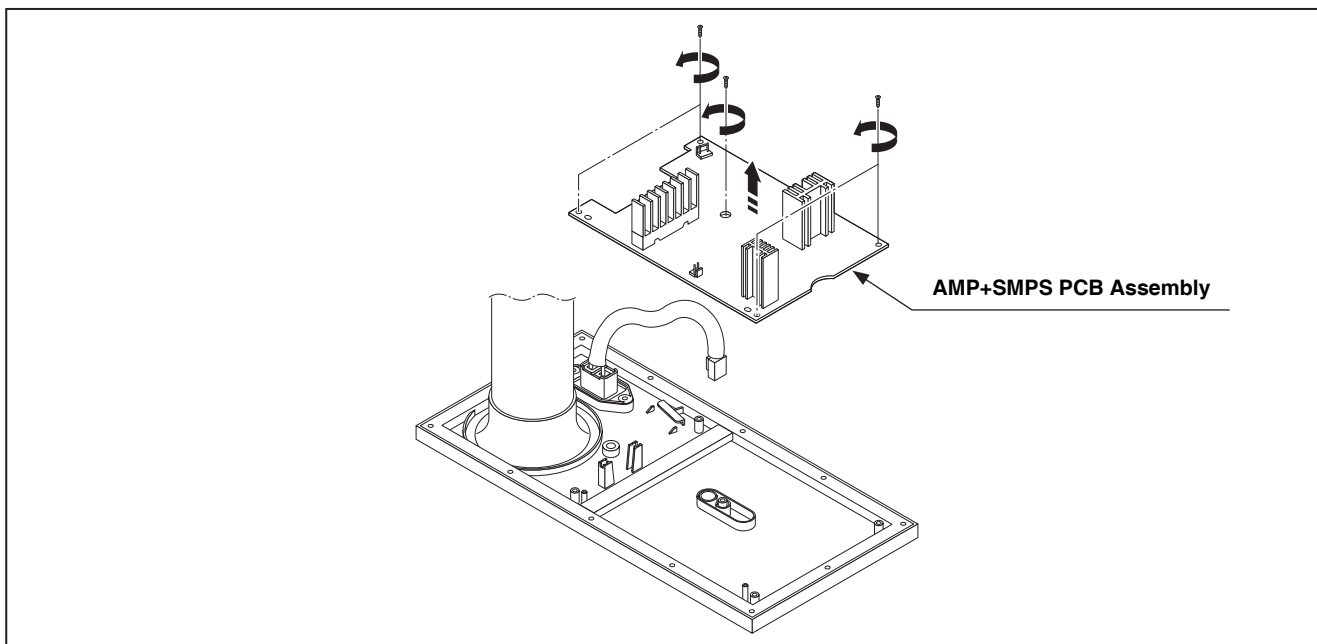
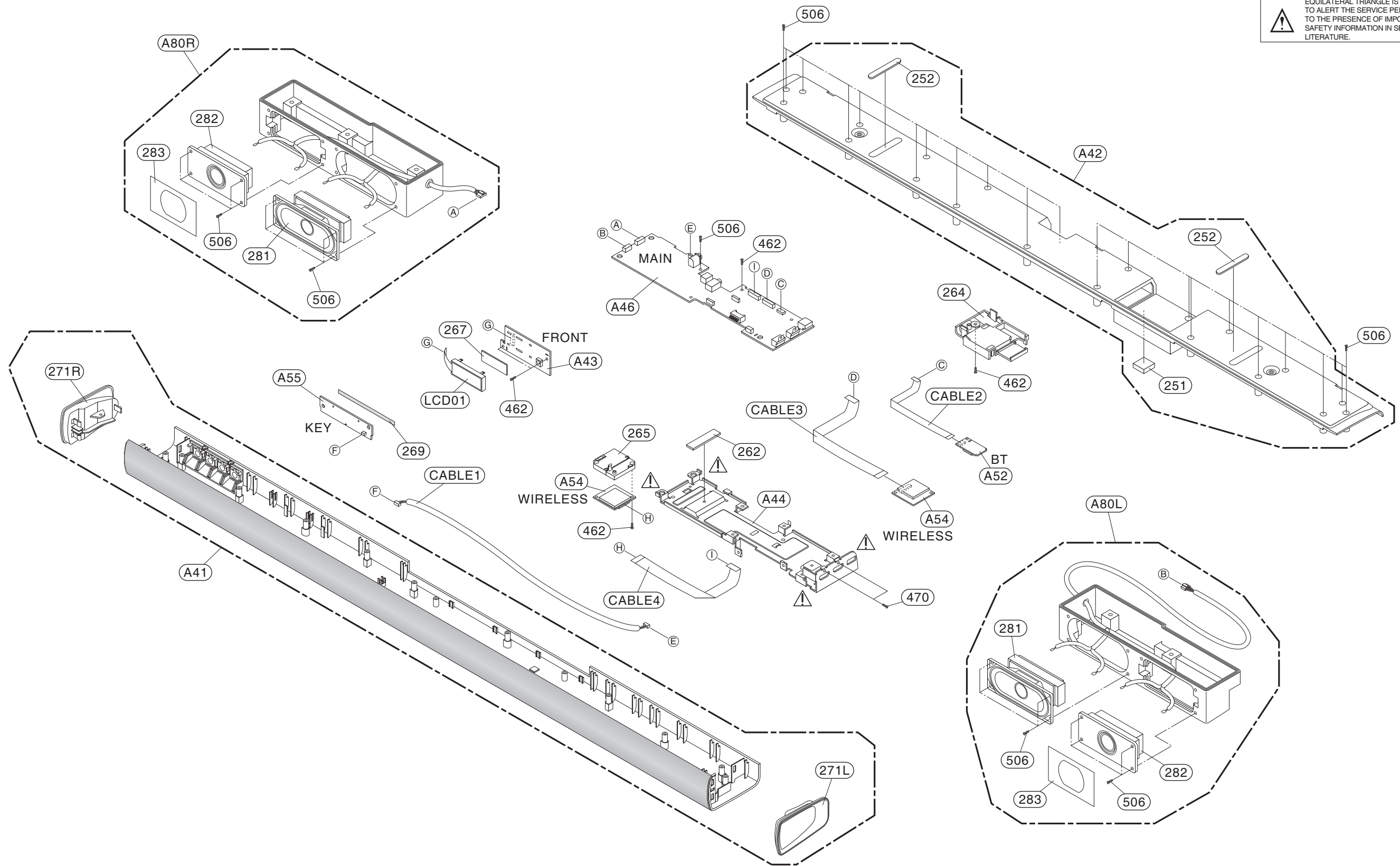

Figure 2-3 (2)

EXPLODED VIEWS

1. MAIN UNIT SECTION

NOTES) THE EXCLAMATION POINT WITHIN AN EQUILATERAL TRIANGLE IS INTENDED TO ALERT THE SERVICE PERSONNEL TO THE PRESENCE OF IMPORTANT SAFETY INFORMATION IN SERVICE LITERATURE.



2. WIRELESS SUBWOOFER SECTION

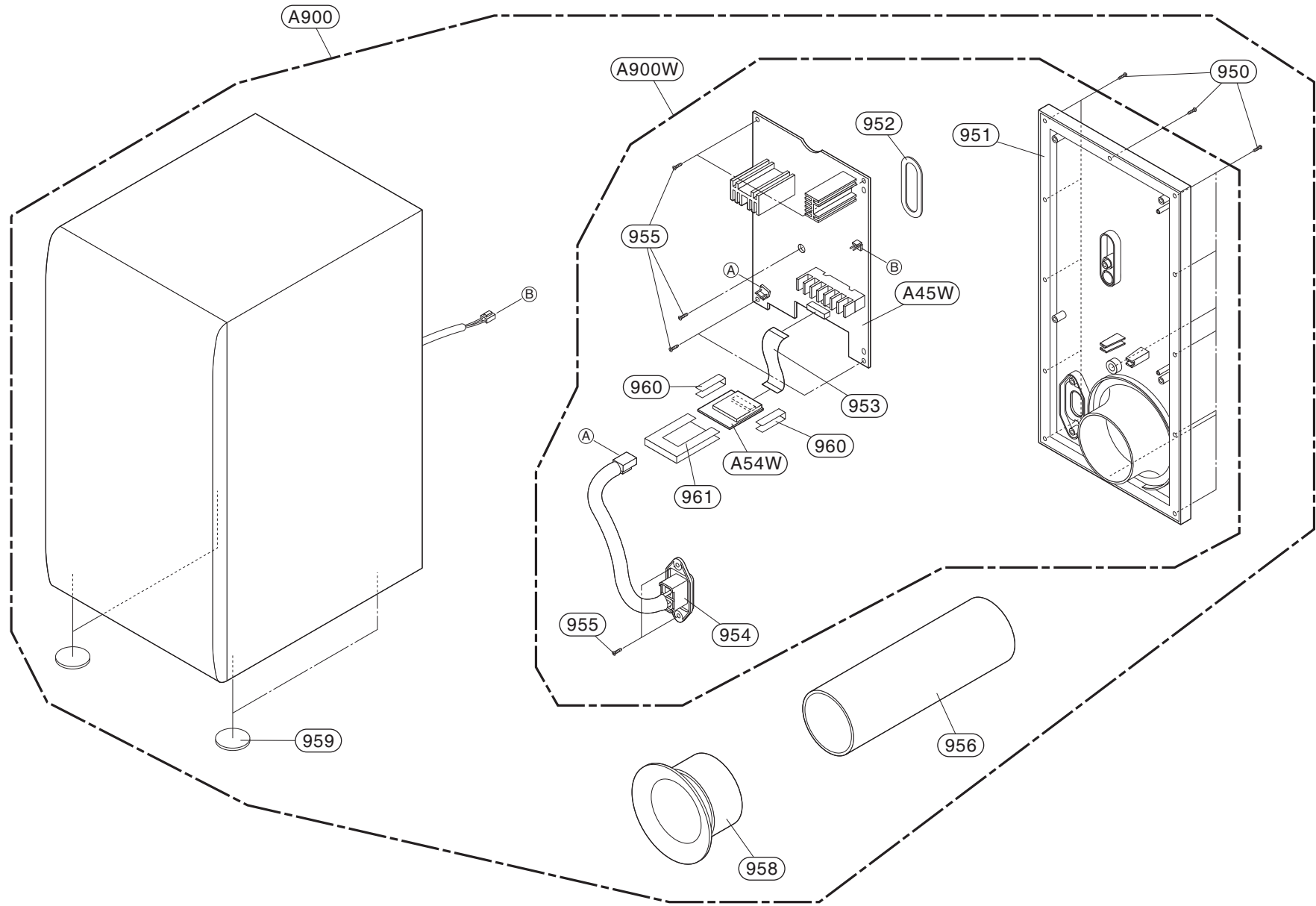

3. PACKING ACCESSORY SECTION

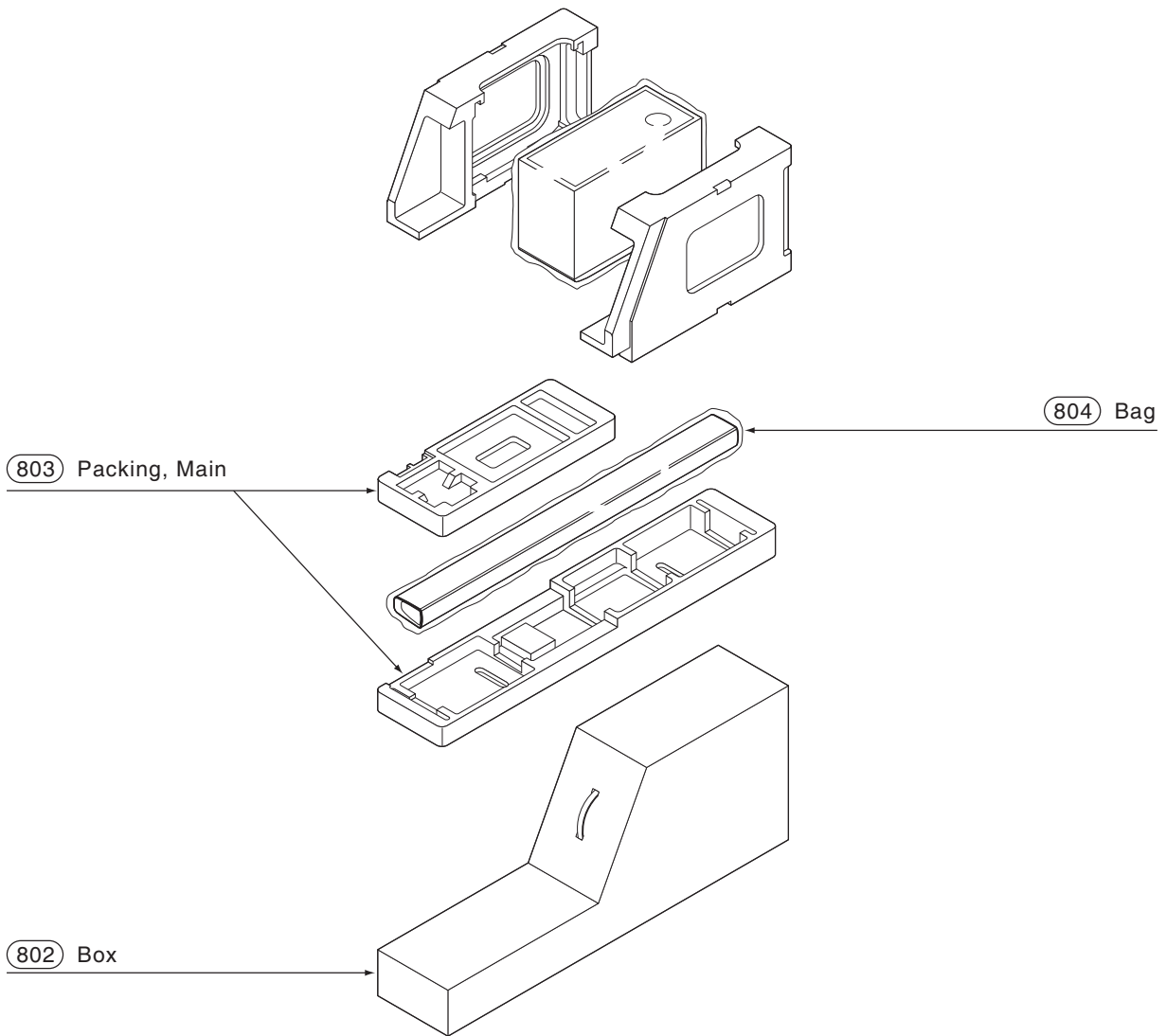
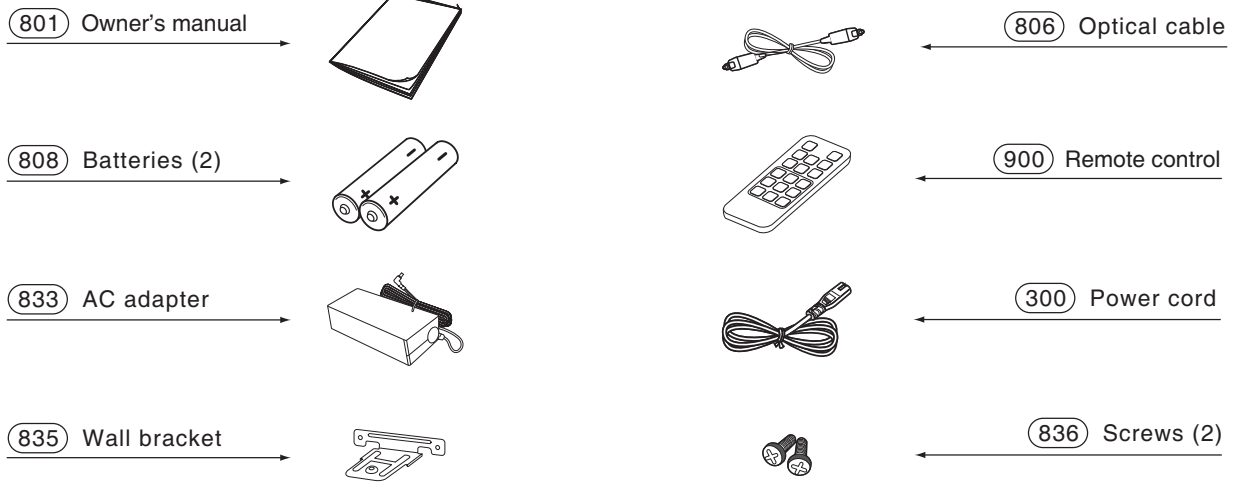

SECTION 3 ELECTRICAL

CONTENTS

WIRING DIAGRAM	3-2
BLOCK DIAGRAMS	3-3
1. SYSTEM BLOCK DIAGRAM	3-3
2. POWER BLOCK DIAGRAM	3-4
ONE POINT REPAIR GUIDE	3-5
1. NO BOOTING WHEN YOU TURN THE UNIT ON, NO MESSAGE OR “HELLO” ON FRONT PANEL	3-5
2. NO SOUND	3-8
3. PROTECTION ERROR.....	3-13
WAVEFORMS OF MAJOR CHECK POINT	3-16
1. CRYSTAL.....	3-16
2. FLASH MEMORY	3-16
3. TACT KEY.....	3-17
4. USB.....	3-18
5. REMOTE CONTROL	3-19
6. OPTICAL.....	3-20
7. PORTABLE	3-21
CIRCUIT VOLTAGE CHART	3-23
1. IC VOLTAGE.....	3-23
2. CAPACITOR VOLTAGE	3-24
3. CONNECTOR VOLTAGE	3-24
PRINTED CIRCUIT BOARD DIAGRAMS	3-25
1. MAIN P. C. BOARD DIAGRAM	3-25
2. FRONT P. C. BOARD DIAGRAM.....	3-27
3. KEY P. C. BOARD DIAGRAM	3-27

WIRING DIAGRAM

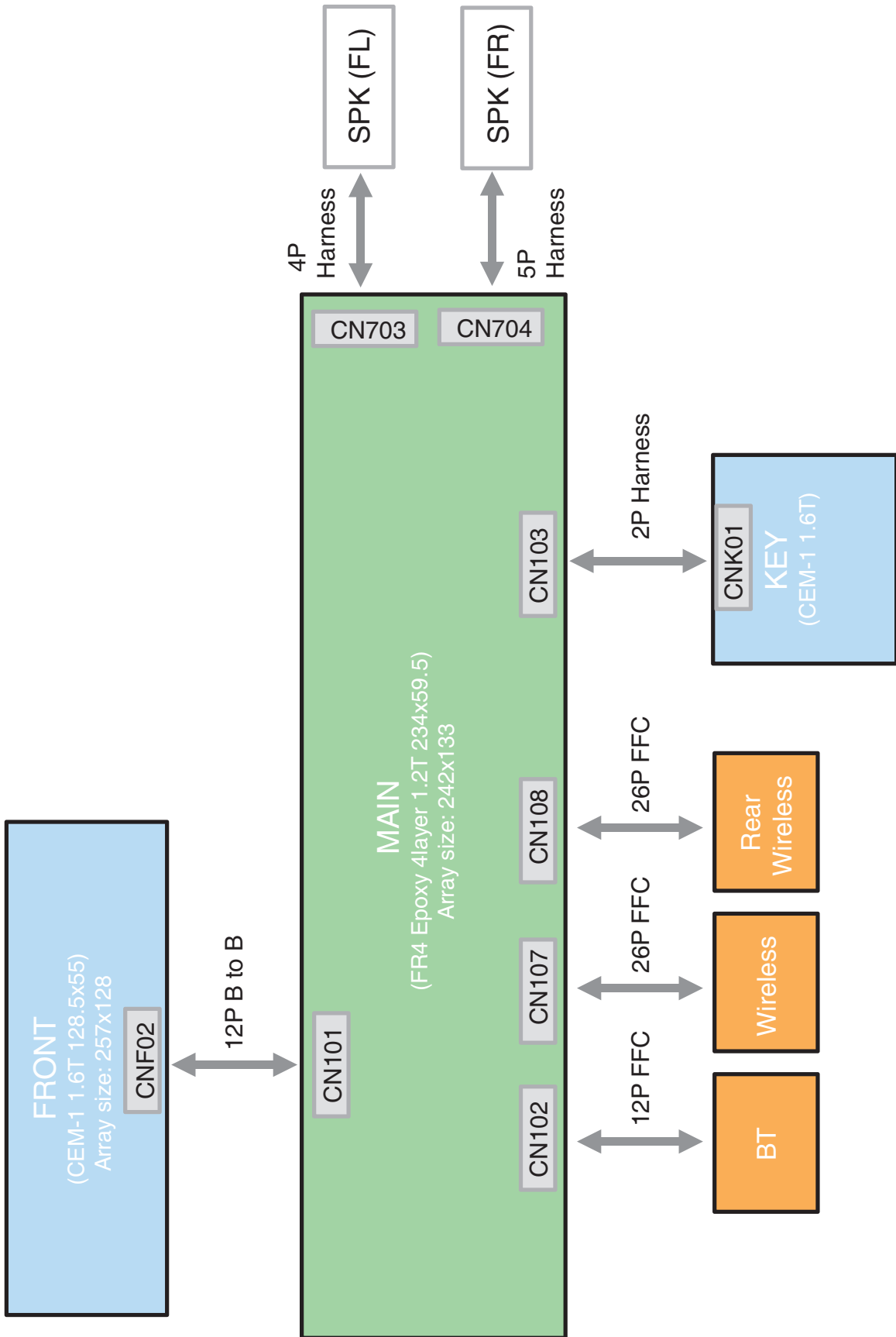

BLOCK DIAGRAMS

1. SYSTEM BLOCK DIAGRAM

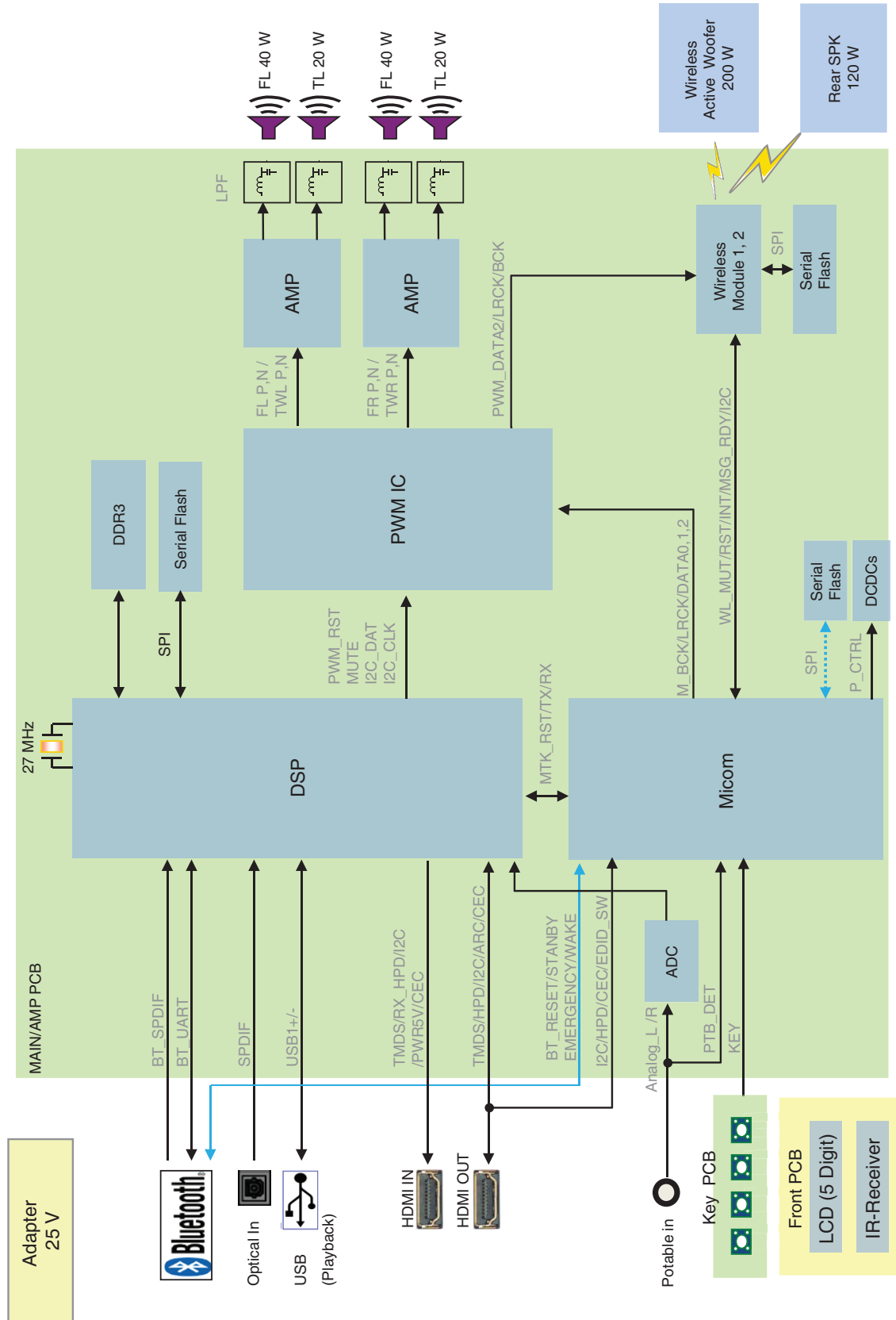

2. POWER BLOCK DIAGRAM

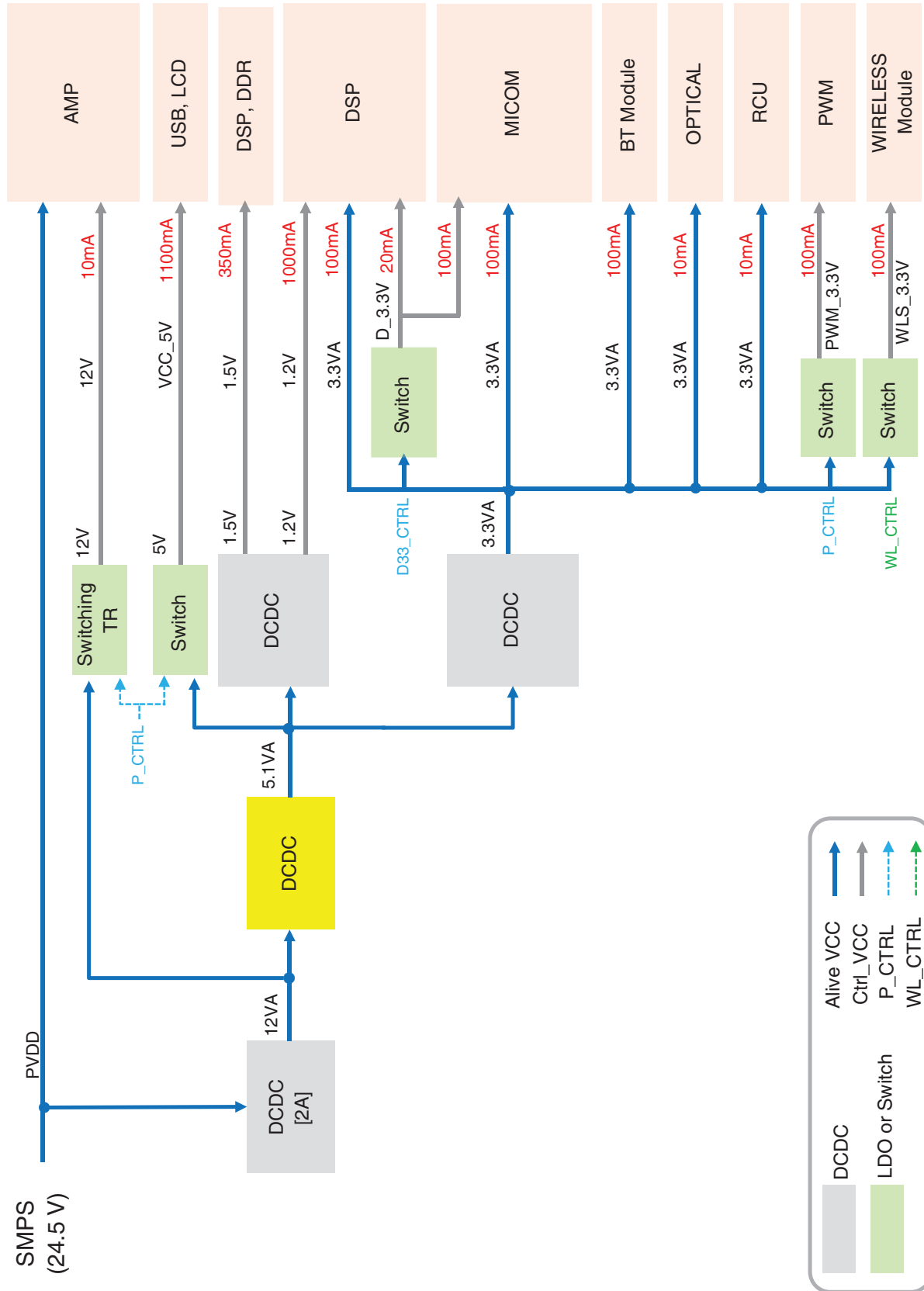

ONE POINT REPAIR GUIDE

1. NO BOOTING WHEN YOU TURN THE UNIT ON, NO MESSAGE OR “HELLO” ON FRONT PANEL

When you turn on your set, no message on the front panel, and stand-by LED doesn't work.

1-1. IC302 System 12 VA (No 12 VA)

1-1-1. Solution

Replace MAIN board.

1-1-2. How to troubleshoot (Countermeasure)

- 1) Please check 25 VA of IC302 pin2 (VIN).
- 2) If 25 VA is abnormal, please check adapter.
- 3) If 25 VA is OK, but 12 VA is abnormal pin3 of IC302 (VOUT), replace MAIN board.

1-1-3. Service hint (Any picture / Remark)

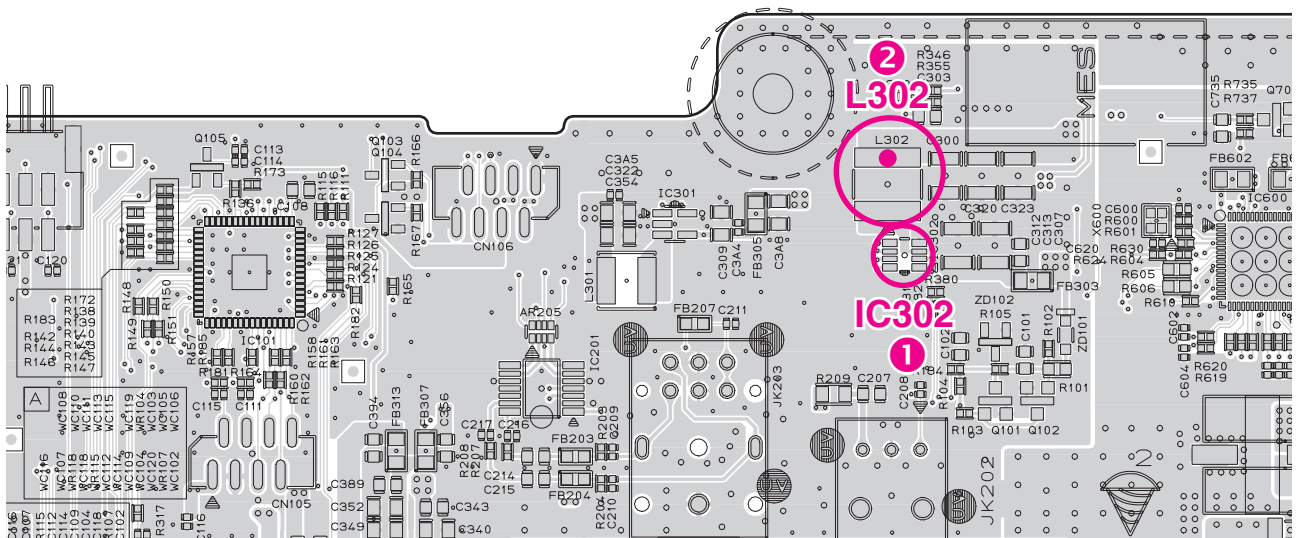
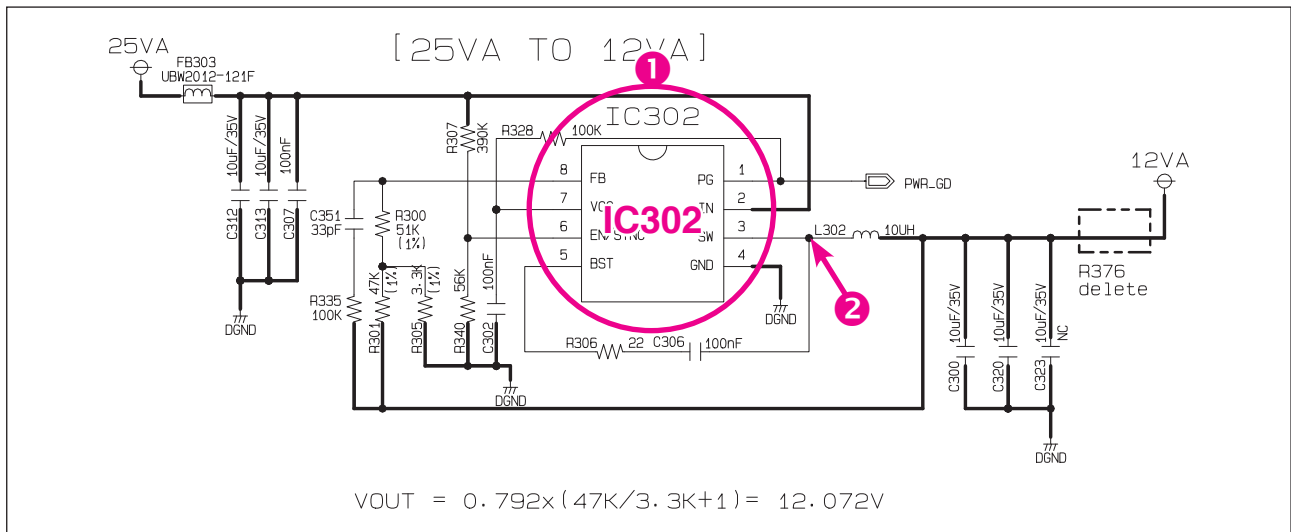

ONE POINT REPAIR GUIDE

NO BOOTING WHEN YOU TURN THE UNIT ON, NO MESSAGE OR “HELLO” ON FRONT PANEL

When you turn on your set, it will blank / no message on front panel, and stand-by LED doesn't work.

1-2. IC301 System 3.3 V (No 3.3 VA)

1-2-1. Solution

Replace MAIN/ FRONT board.

1-2-2. How to troubleshoot (Countermeasure)

- 1) Please check 3.3 VA of IC301 pin3.
- 2) If 3.3 VA is abnormal, replace MAIN board.
- 3) If 5.1 VA is OK, replace FRONT board.

1-2-3. Service hint (Any picture / Remark)

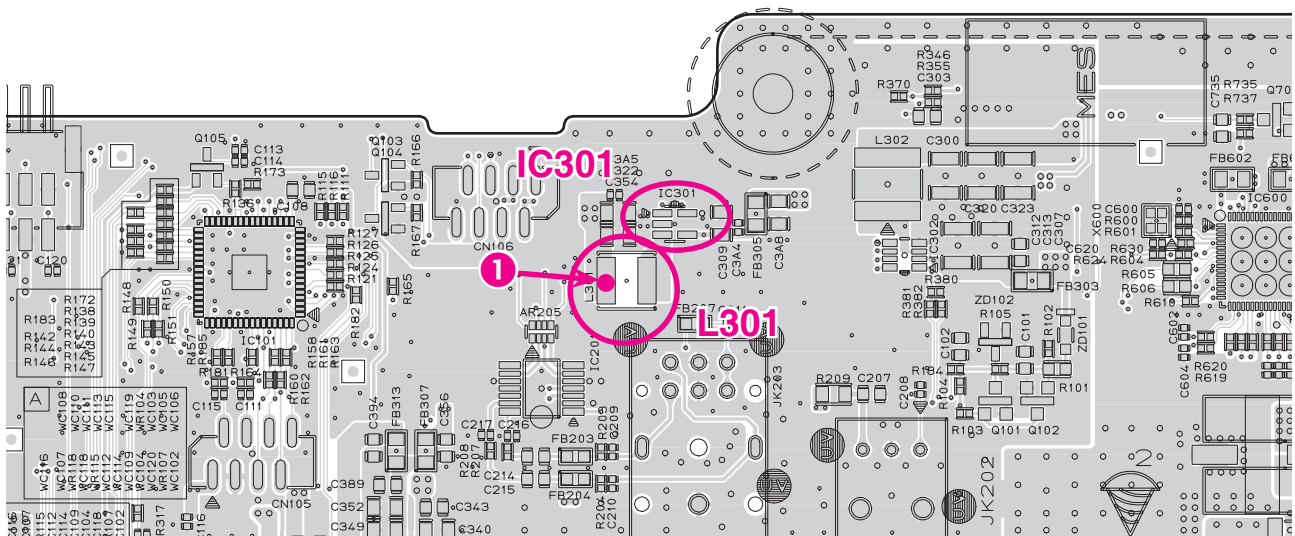
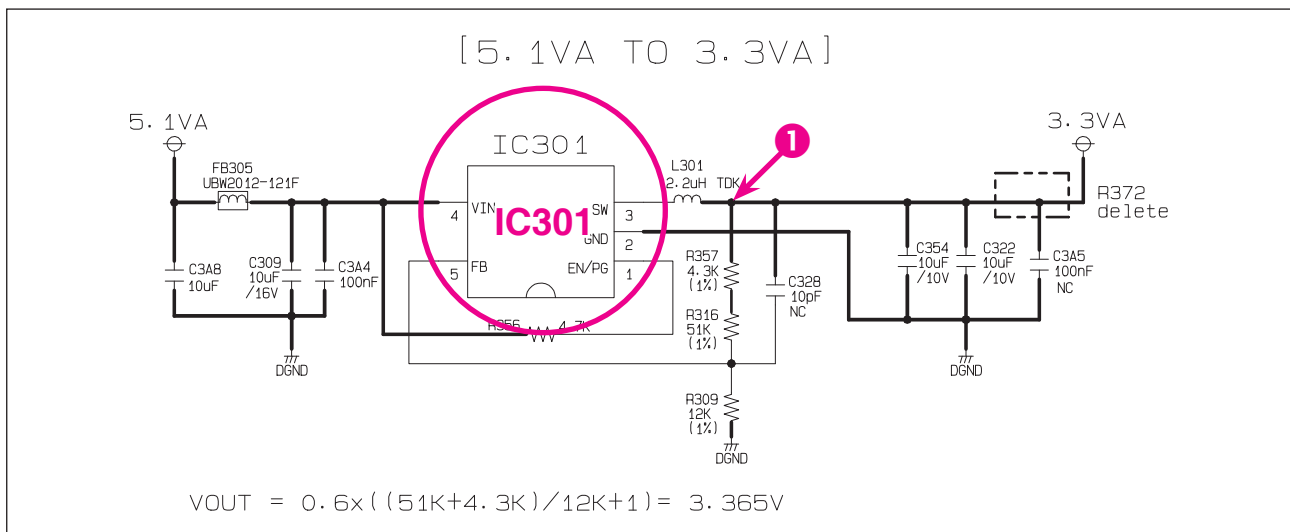

< MAIN board top view >

ONE POINT REPAIR GUIDE

NO BOOTING WHEN YOU TURN THE UNIT ON, NO MESSAGE OR “HELLO” ON FRONT PANEL

When you turn on your set, it will blank / no message on front panel, and stand-by LED doesn't work.

1-3. LCD System power 5 V, 3.3 VA (No 5 V, 3.3 VA)

1-3-1. Solution

Replace MAIN/ FRONT board.

1-3-2. How to troubleshoot (Countermeasure)

- 1) Please check CNF01 3.3 VA, 5 V of CNF01 pin6, pin7.
- 2) If 3.3 VA, 5 V is abnormal, replace MAIN board.
- 3) If 3.3 VA, 5 V OK, replace FRONT board.

1-3-3. Service hint (Any picture / Remark)

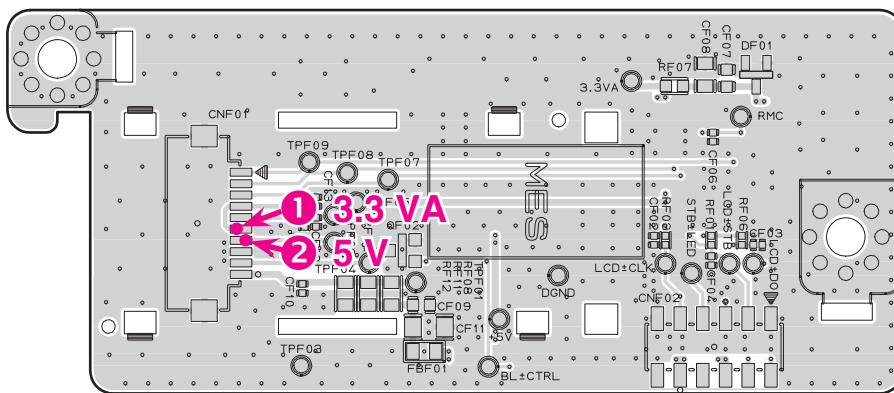
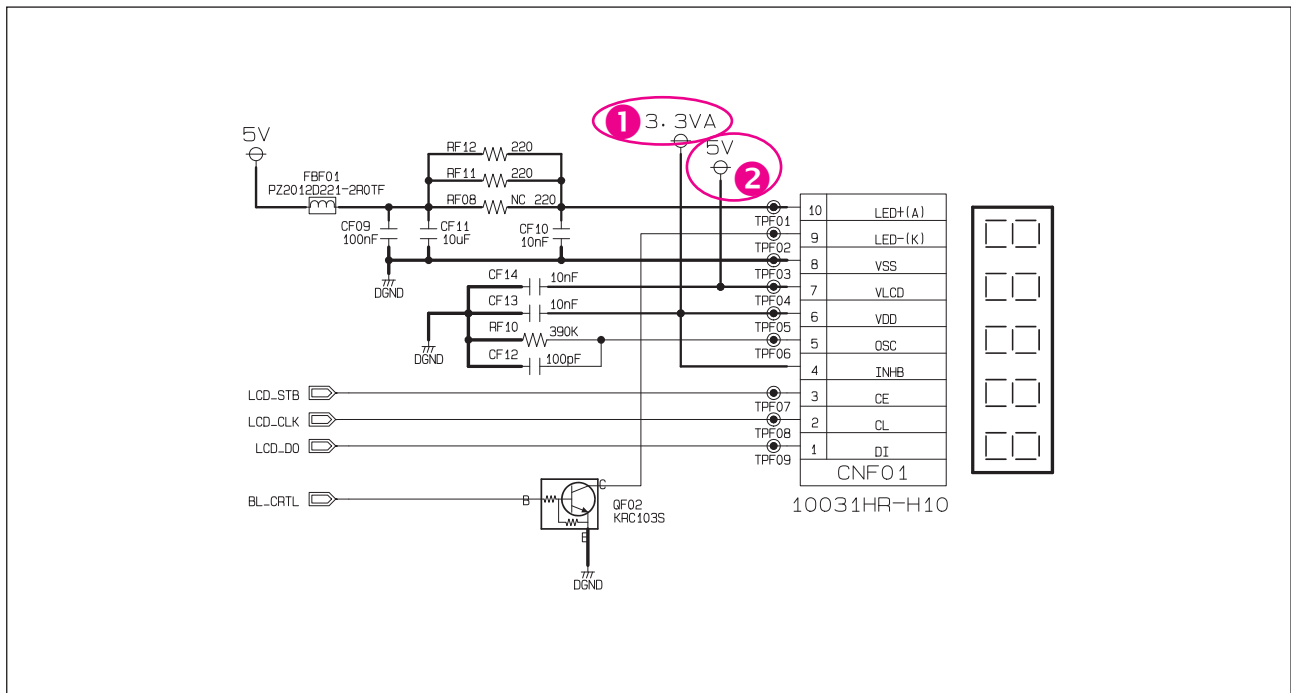

< FRONT board bottom view >

ONE POINT REPAIR GUIDE

2. NO SOUND

2-1. BLUETOOTH

2-1-1. Solution

Replace MAIN board.

2-1-2. How to troubleshoot (Countermeasure)

- 1) Please check status of Bluetooth cable connection. (at CN102 and BT module)
- 2) Please check 3.3 VA (at pin1 of CN102).
If 3.3 V is OK, please check BT_RST, BT_SPDIF, BT_RX, BT_TX (pin2, 4, 11, 12).
If no signal, please replace MAIN board.

2-1-3. Service hint (Any picture / Remark)

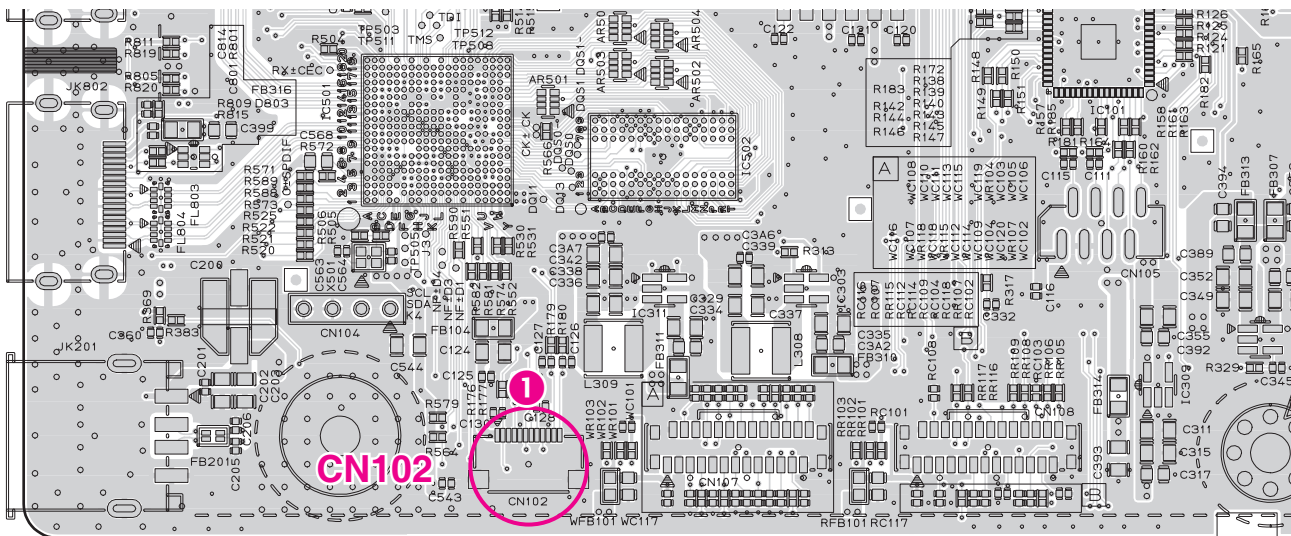
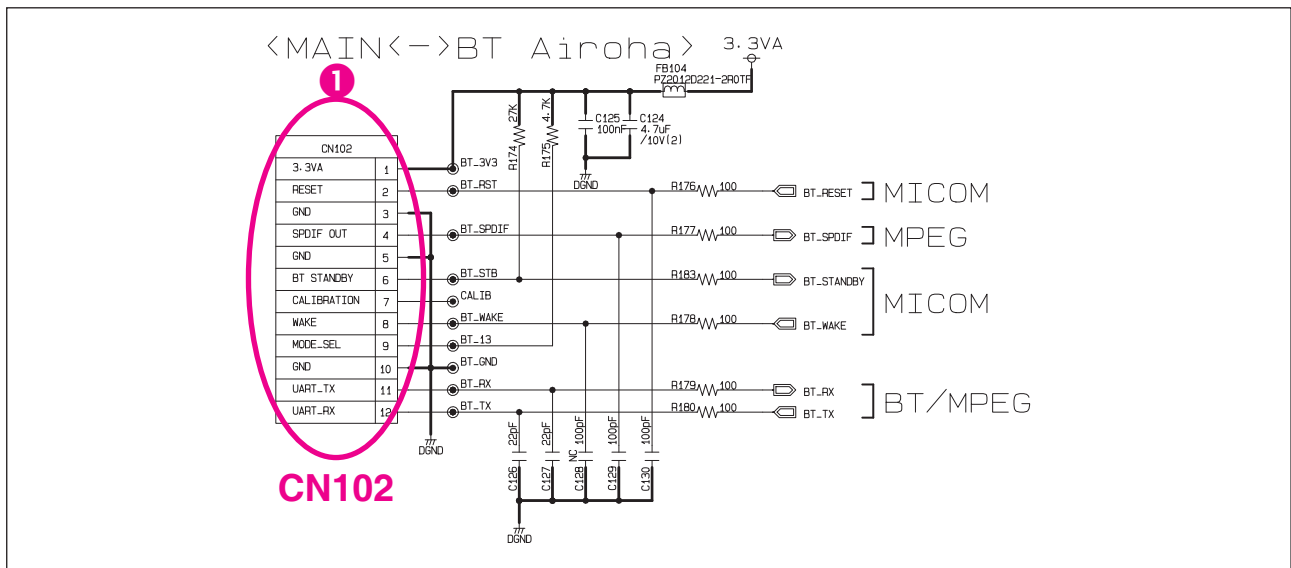

< MAIN board top view >

ONE POINT REPAIR GUIDE

NO SOUND

2-2. OPTICAL

2-2-1. Solution

Replace MAIN board.

2-2-2. How to troubleshoot (Countermeasure)

- 1) Please check 3.3 VA at R209.
- 2) If 3.3 VA is ok, please check OPT_IN signal (C208) when OPTICAL mode.
- 3) If signal is abnormal, replace MAIN board.

2-2-3. Service hint (Any picture / Remark)

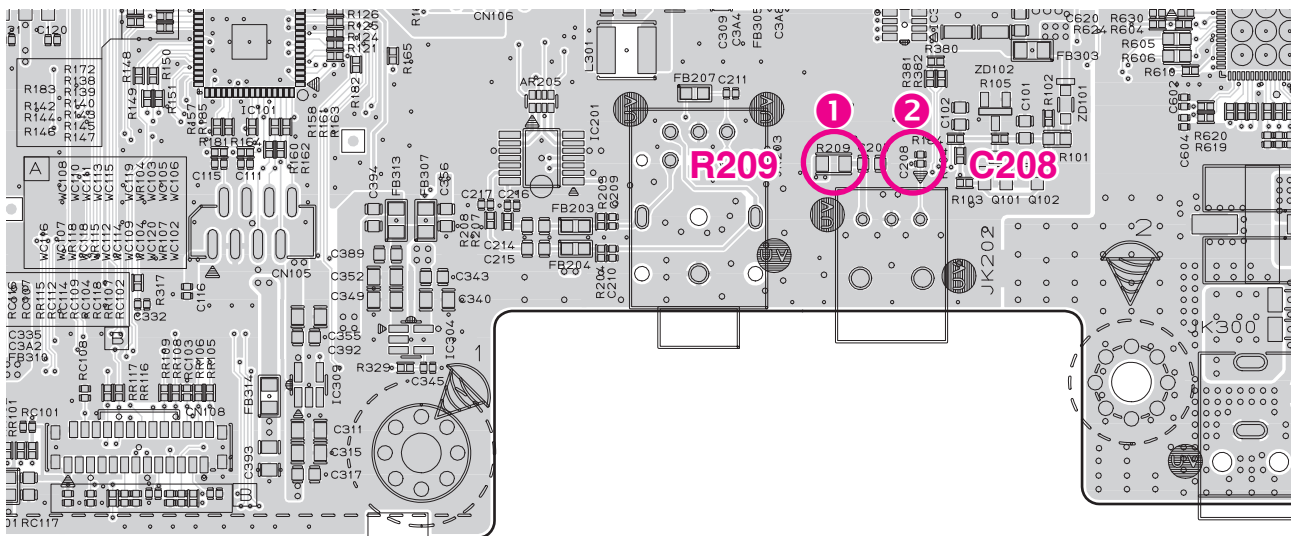
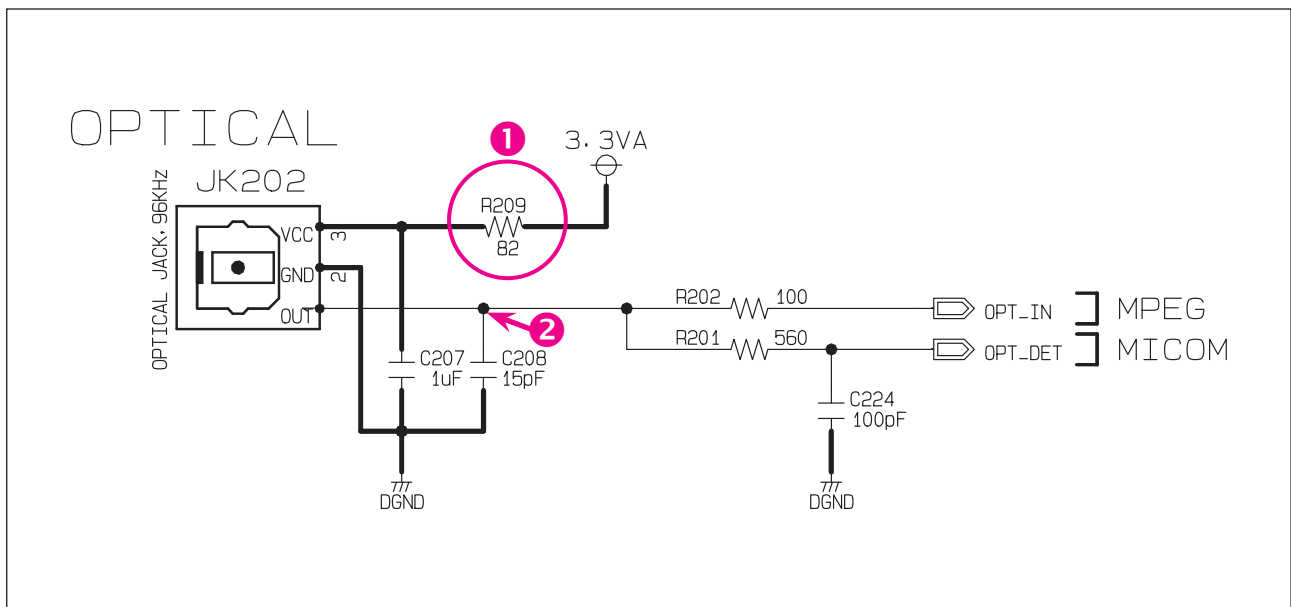

< MAIN board top view >

ONE POINT REPAIR GUIDE

NO SOUND

2-3. HDMI

2-3-1. Solution

Replace MAIN board.

2-3-2. How to troubleshoot (Countermeasure)

- 1) Please check soldering status of HDMI jack and check HDMI_5.1VA at IC308 pin1.
- 2) If soldering status and 5.1 VA are abnormal, replace MAIN board.

2-3-3. Service hint (Any picture / Remark)

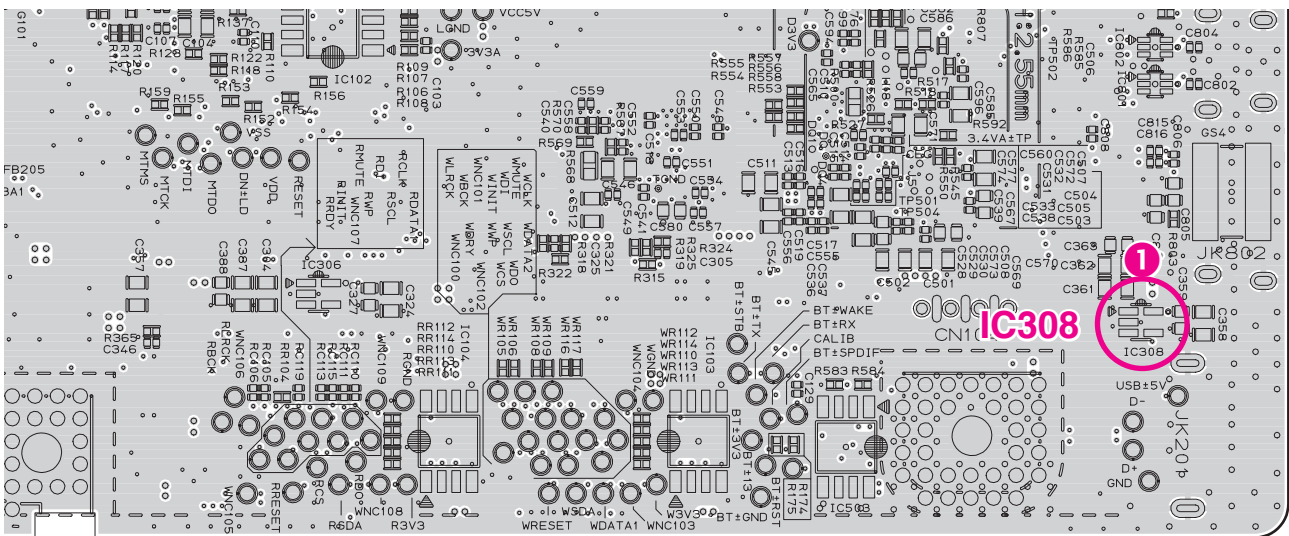
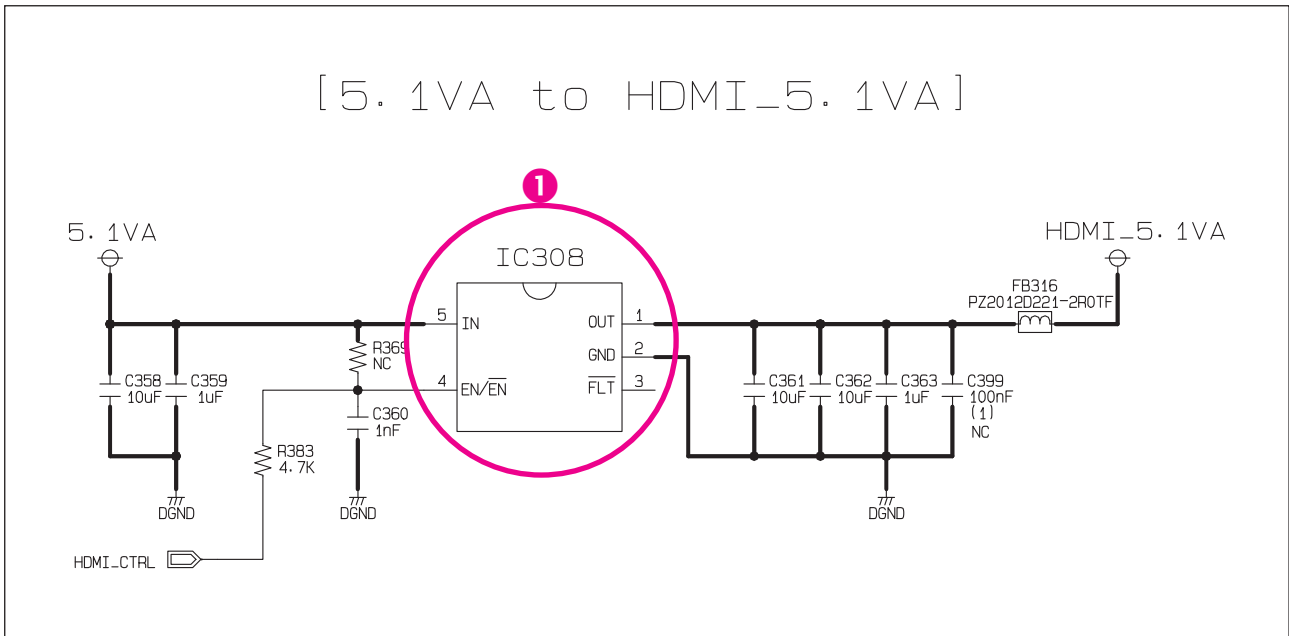

< MAIN board bottom view >

ONE POINT REPAIR GUIDE

NO SOUND

2-5. USB

2-5-1. Solution

Replace MAIN board.

2-5-2. How to troubleshoot (Countermeasure)

- 1) Please check USB Jack and FB201 soldering status. And check 5 V at JK201 pin1.
- 2) If soldering status and voltage has abnormal status, replace MAIN board.

2-5-3. Service hint (Any picture / Remark)

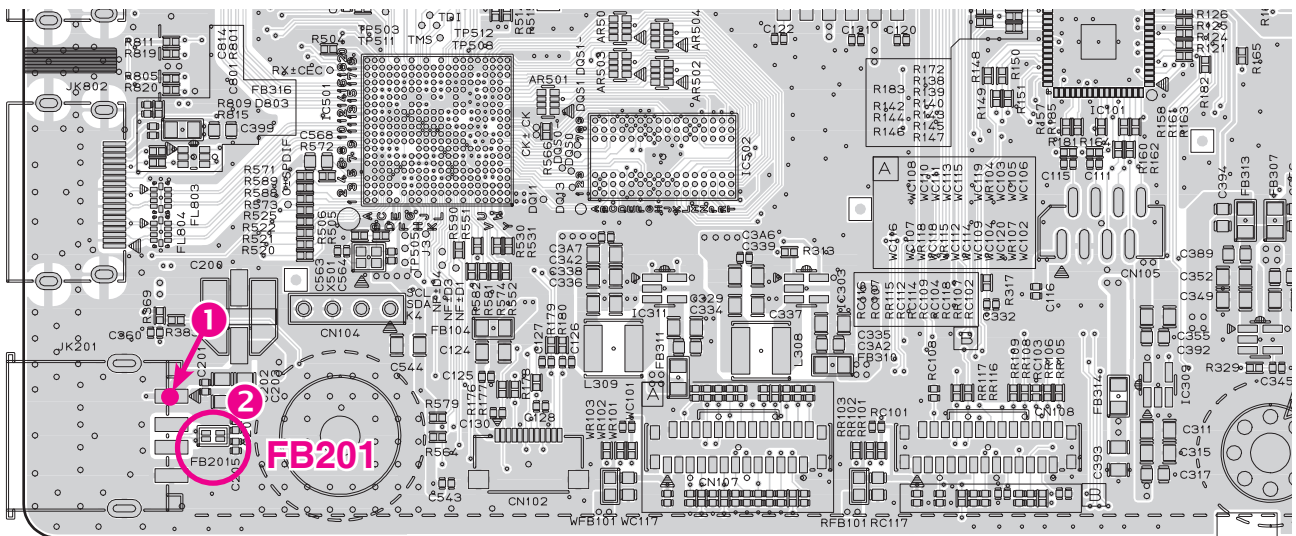
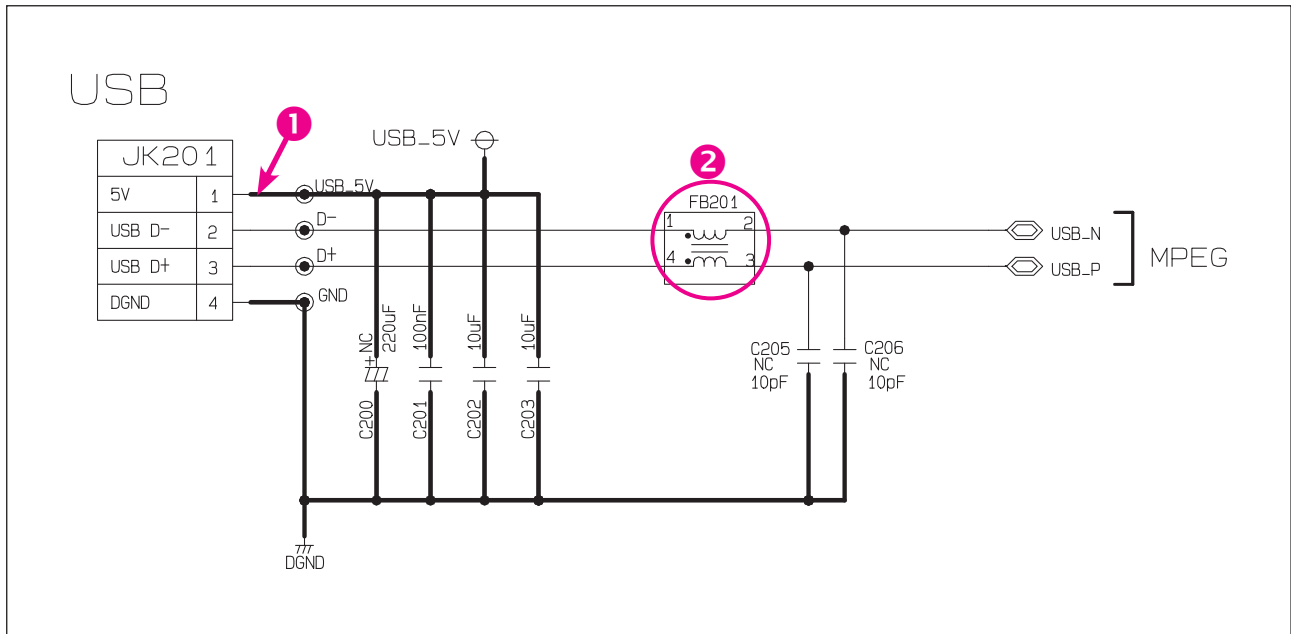

< MAIN board top view >

ONE POINT REPAIR GUIDE

3. PROTECTION ERROR

No display or No Sound.

3-1. D(DC) PROTECTION

3-1-1. Solution

Replace MAIN board.

3-1-2. How to troubleshoot (Countermeasure)

- 1) Check DC Voltage of speaker out FL+/-, TWL+/- (CN703 pin1, 2, 3, 4) and FR+/-, TWR+/- (CN704 pin1, 2, 4, 5).
- 2) Check resistor crack, cold solder of PWM IC out (AR601, AR602)
- 3) If PWM IC out is ok and speaker out (FL+/-, FR+/-, TWL+/-, TWR+/-) has DC voltage, replace MAIN board.

3-1-3. Service hint (Any picture / Remark)

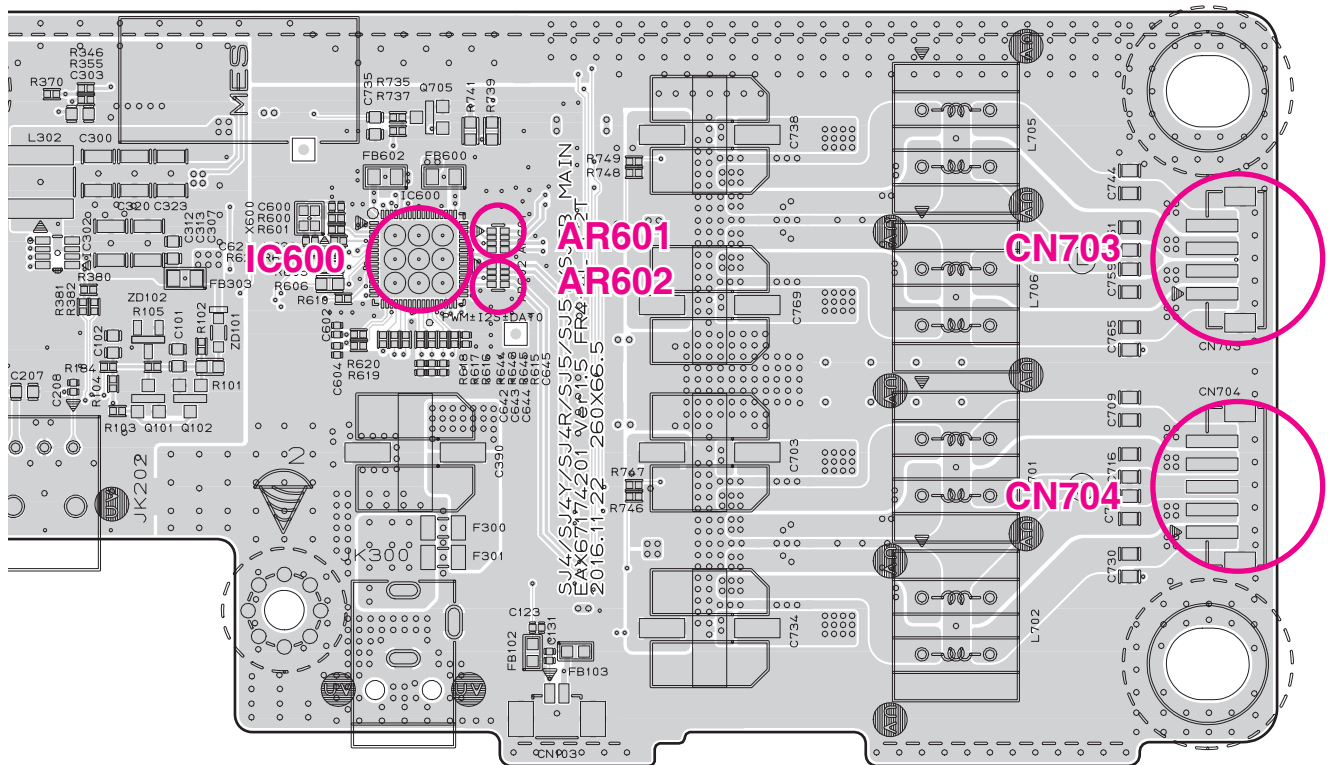

< MAIN board top view >

ONE POINT REPAIR GUIDE

PROTECTION ERROR

No display or No Sound.

3-2. S(SHUT DOWN) PROTECTION

3-2-1. Solution

Replace MAIN board.

3-2-2. How to troubleshoot (Countermeasure)

- 1) Check PVDD voltage (25 V) of IC700, IC701 pin38, 37, 36.
- If PVDD voltage has 8.5 V under, refer to STEP 1-1.
- 2) Check GVDD, VDD voltage (12 V) of IC700, IC701 pin1, 2.
- If GVDD, VDD voltage has 8.5 V under, refer to STEP 1-1.
- 3) Check impedance (4 Ω) of speaker unit.
- If impedance of speaker unit has 1 Ω under, replace speaker unit.
- 4) If check point 1), 2), 3) is ok, replace MAIN board.

3-2-3. Service hint (Any picture / Remark)

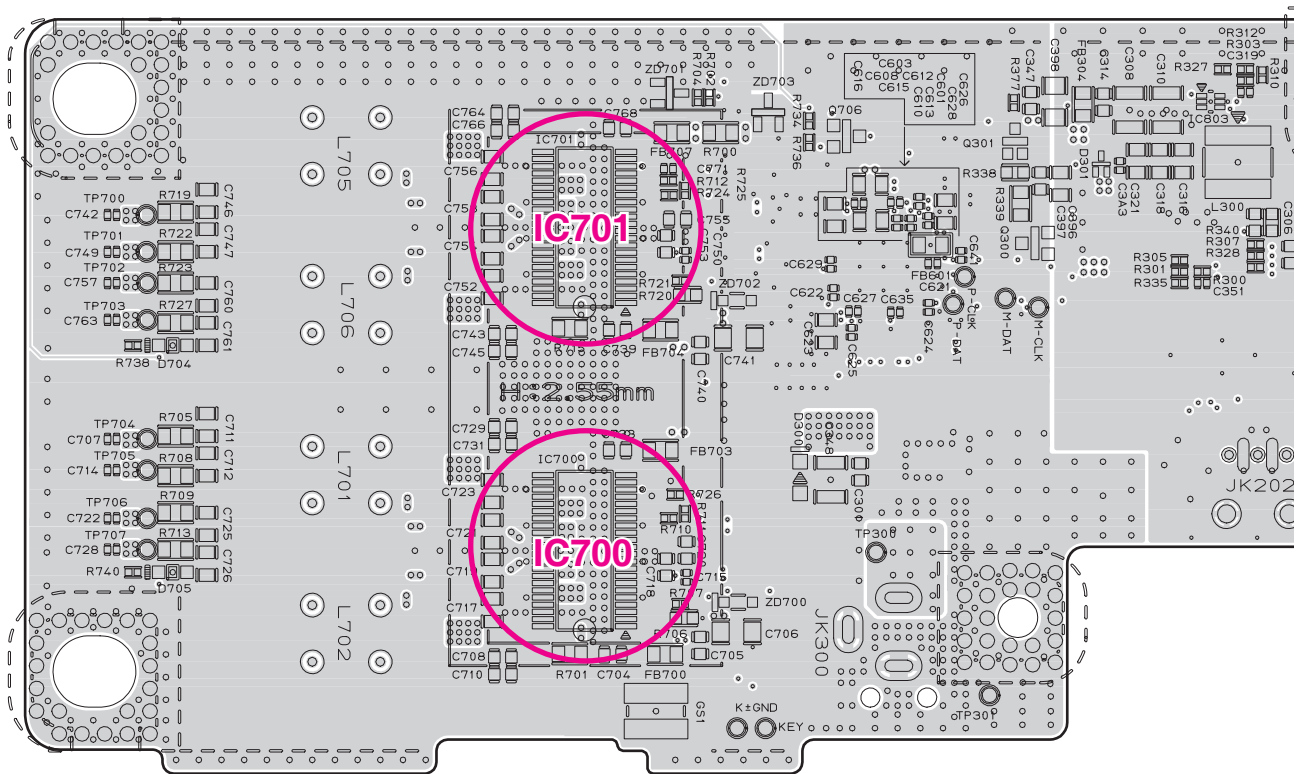

< MAIN board bottom view >

ONE POINT REPAIR GUIDE

PROTECTION ERROR

No display or No Sound.

3-3. B(BURNT) PROTECTION

3-3-1. Solution

Replace MAIN board.

3-3-2. How to troubleshoot (Countermeasure)

- 1) Check voltage 12 V of IC700, IC701 at pin1 ~ 2, if 12 V has problem refer to STEP 1-1.
- 2) If 12 V is OK, replace MAIN board.

3-3-3. Service hint (Any picture / Remark)

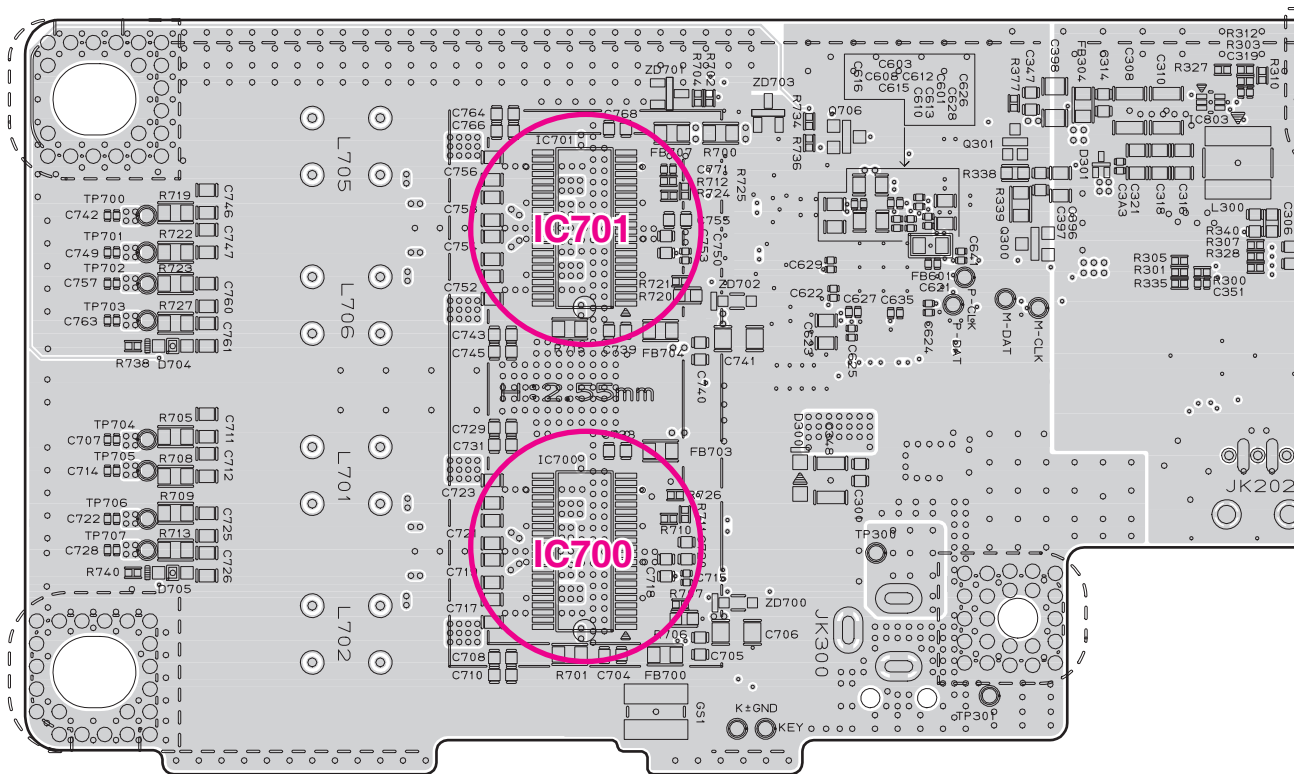

< MAIN board bottom view >

WAVEFORMS OF MAJOR CHECK POINT

1. CRYSTAL

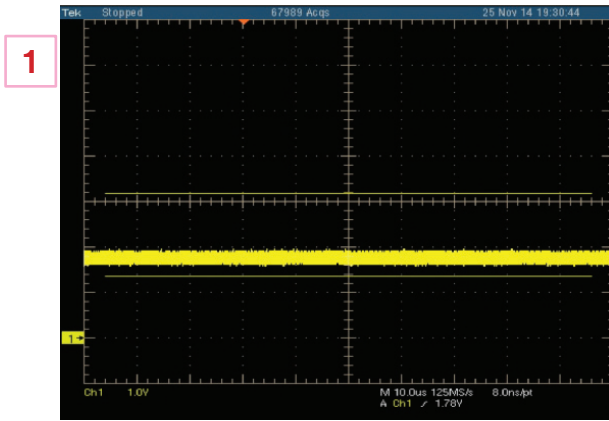

FIG 1-1. X501 (27 MHz)

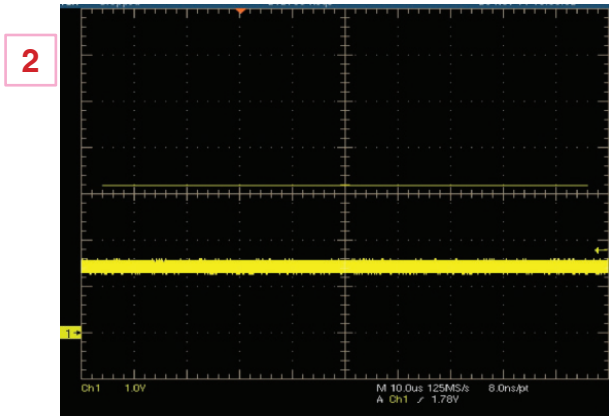
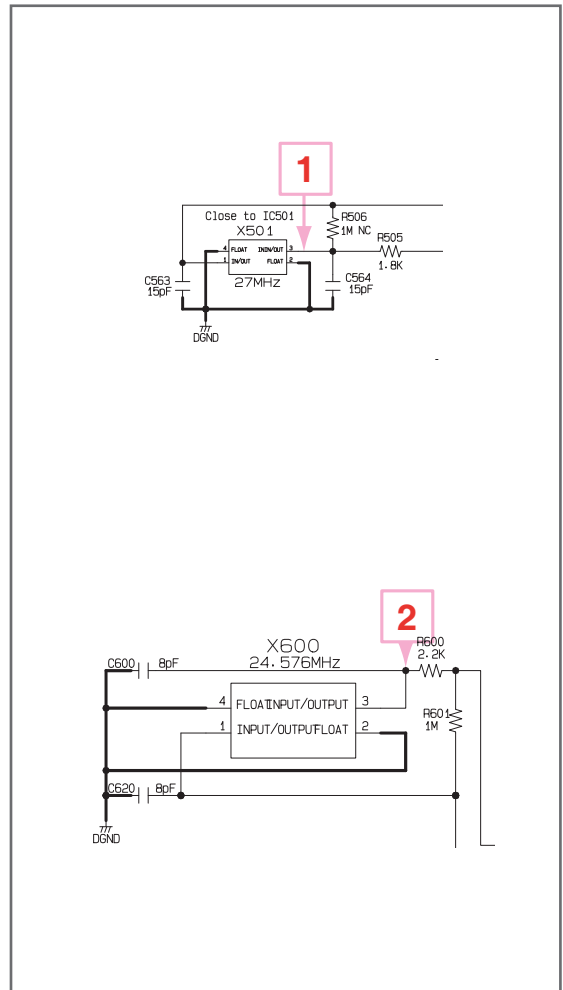
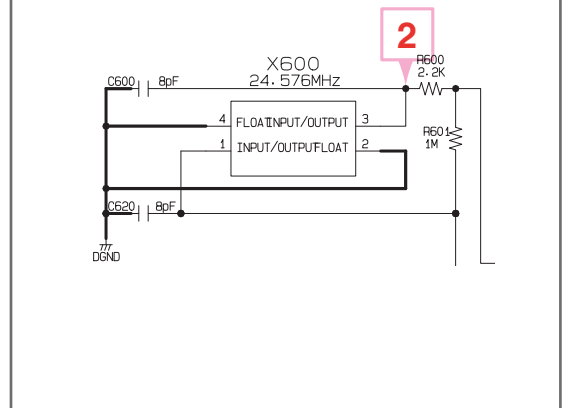

FIG 1-2. X600 (24.576 MHz)



2. FLASH MEMORY

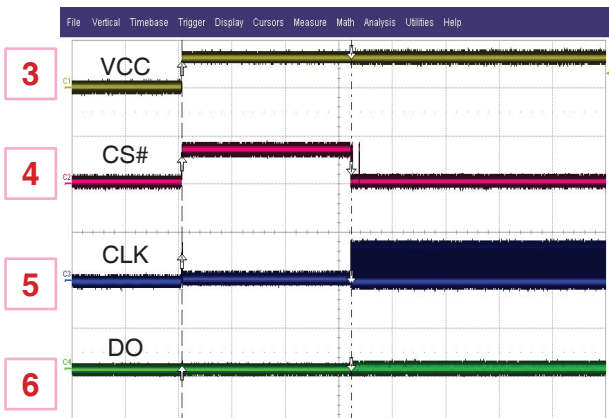
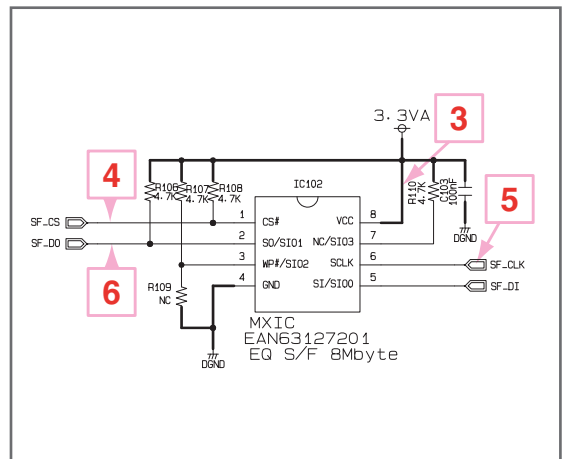

FIG 2. VCC, CS#, CLK, DO



3. TACT KEY

7

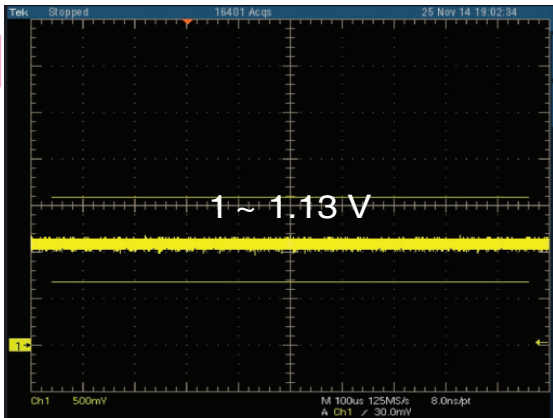

FIG 3-1. Press Power Key

7



FIG 3-2. Press FUNC Key

7

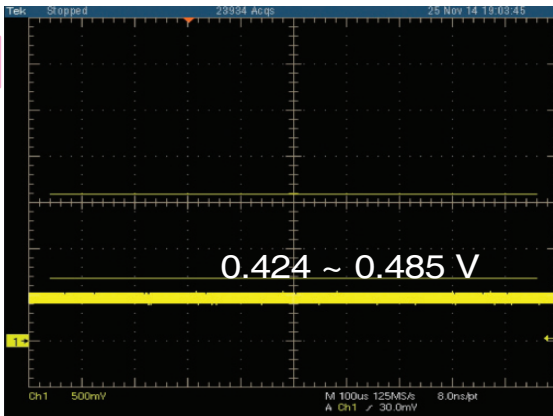

FIG 3-3. Press VOL - Key

7

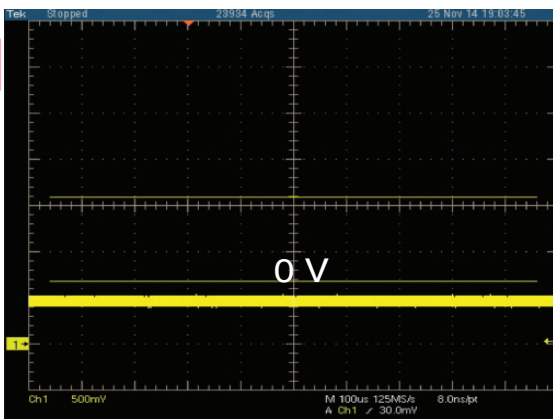
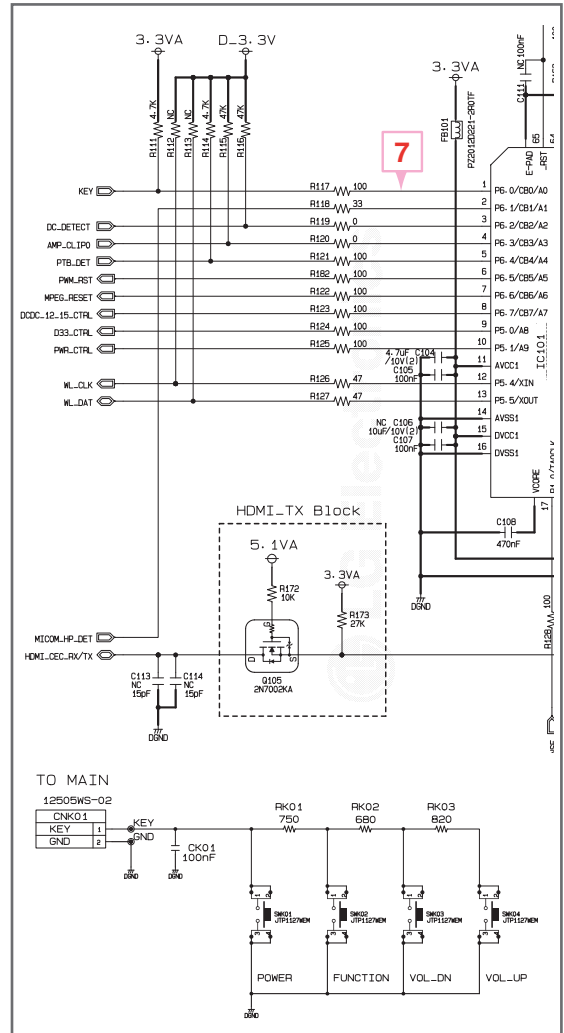

FIG 3-4. Press VOL + Key



4. USB

8

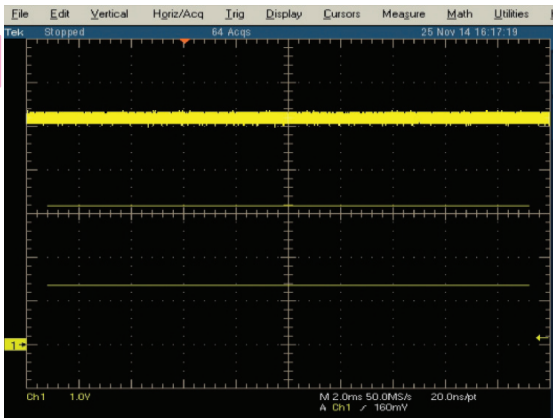

FIG 4-1. 5 V Voltage

9

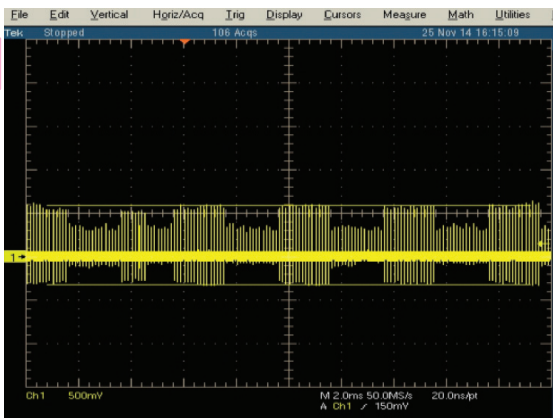

FIG 4-2. USB D+

10

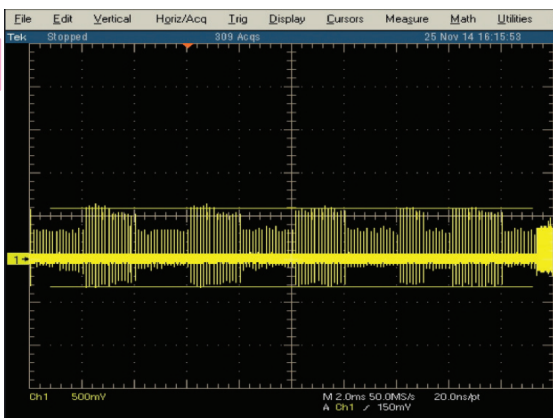
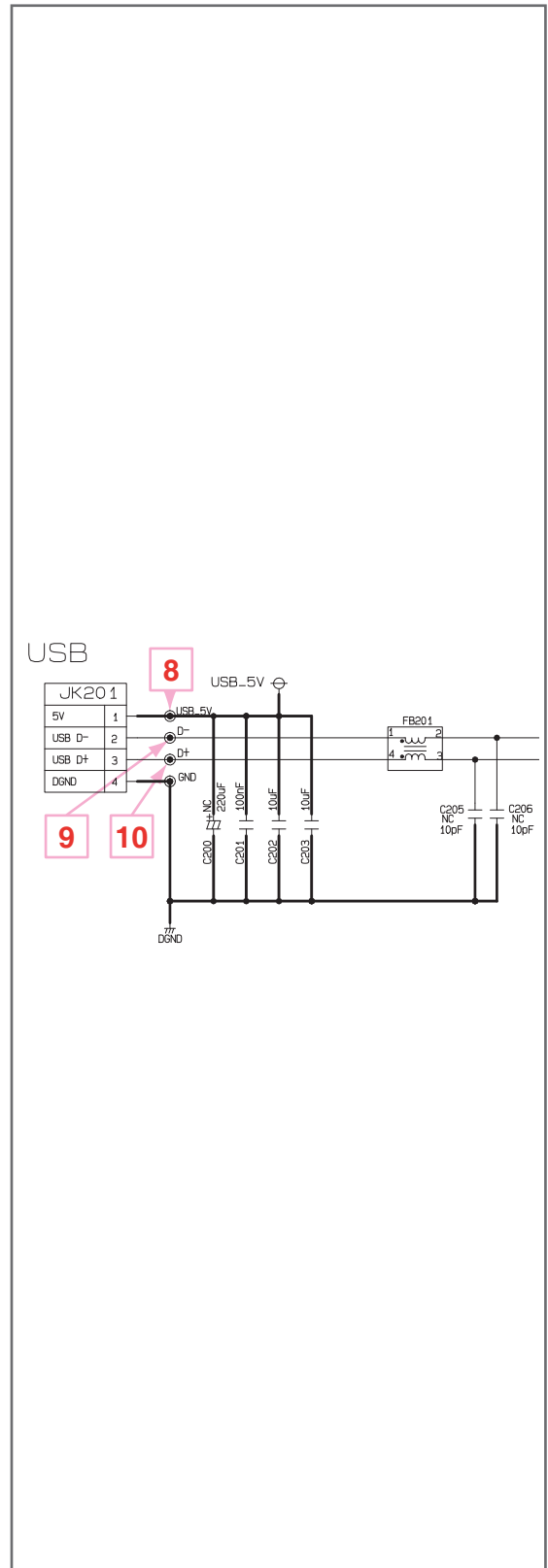

FIG 4-3. USB D-



5. REMOTE CONTROL

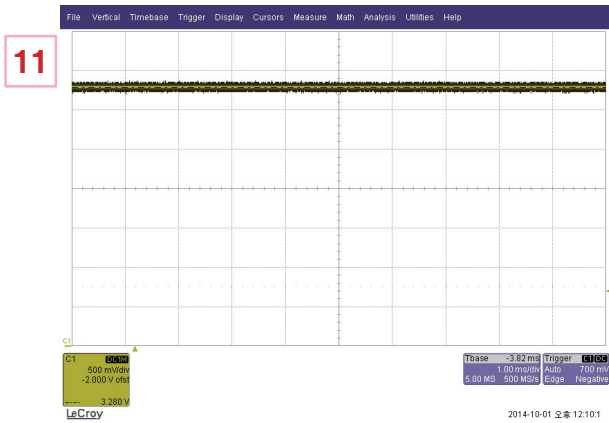

FIG 5-1. Input Voltage

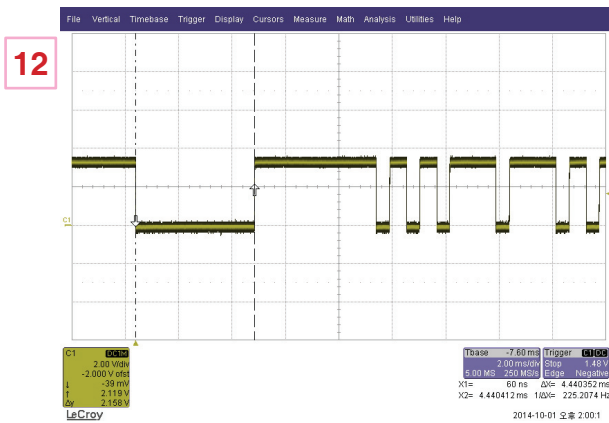

FIG 5-2. Low Timing

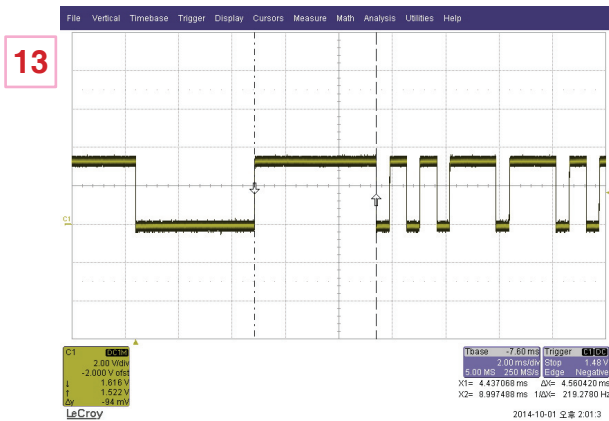
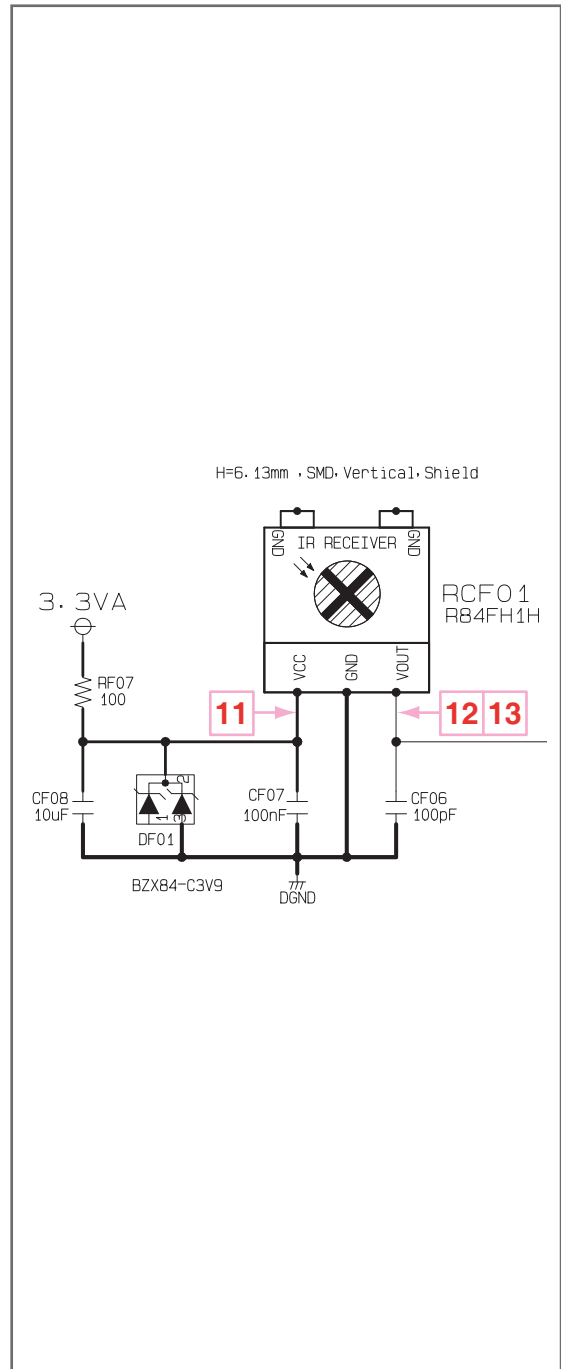

FIG 5-3. High Timing



Item	Measured	Spec.
Input Level	3.3 V	IR Receiver Spec: 2.7 ~ 5.5 V
“ Low” Timing	4.4 ms	3.6 ms ~ 5.04 ms
“ High” Timing	4.48 ms	4.08 ms ~ 5.04 ms

6. OPTICAL

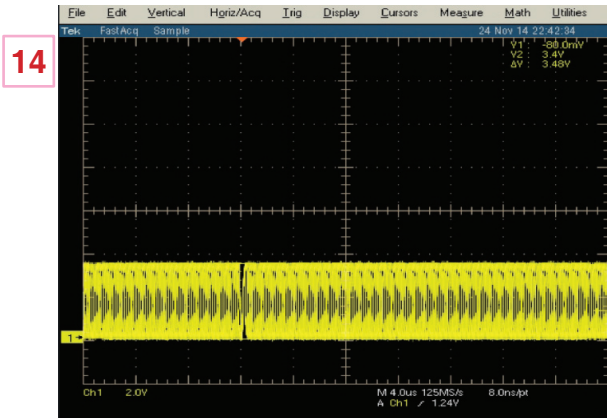

FIG 6-1. OPT_IN

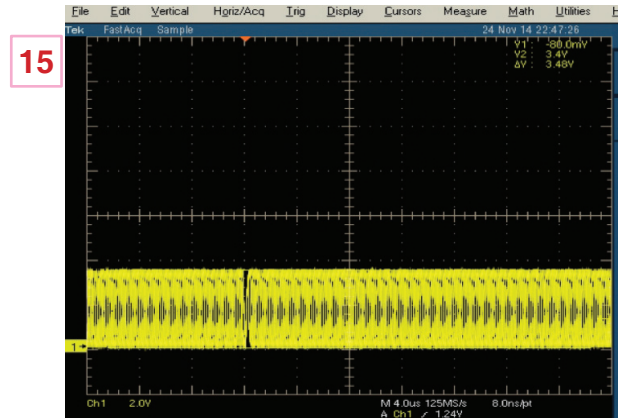
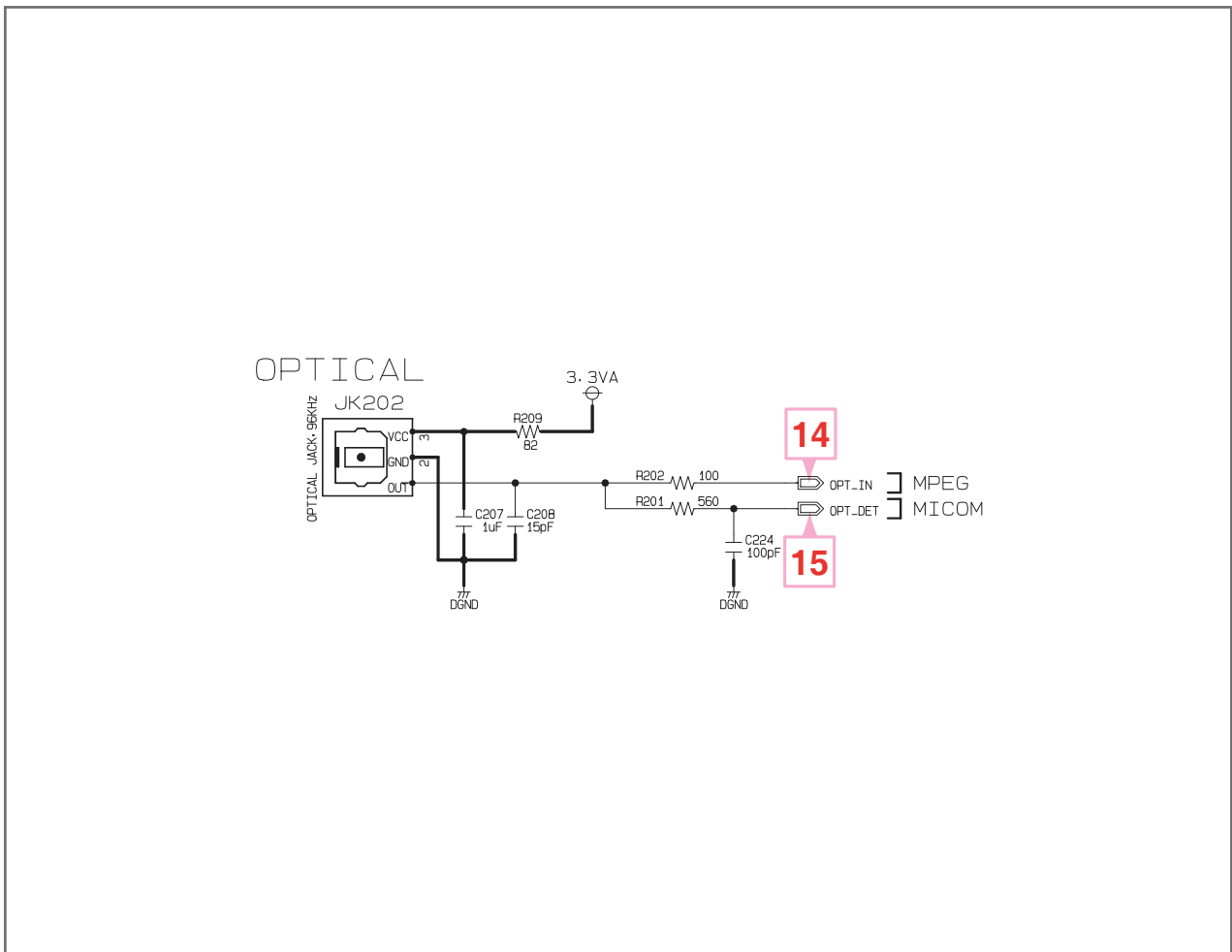

FIG 6-2. OPT_DET



7. PORTABLE

16

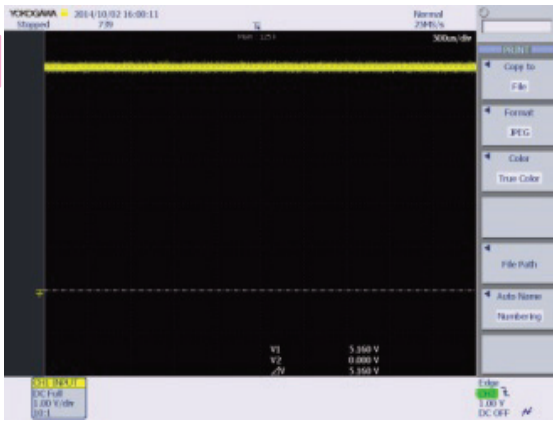

FIG 7-1. ADC IC 5 V

17

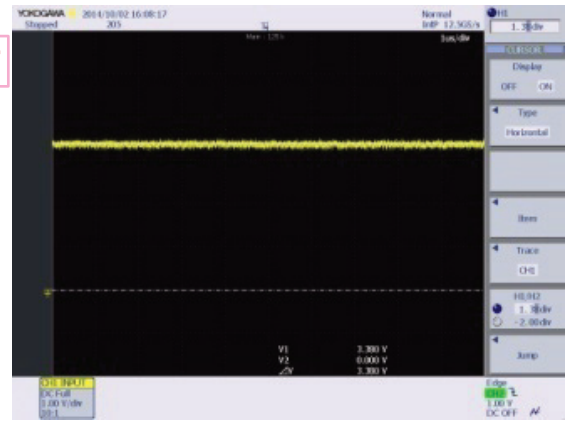

FIG 7-2. ADC IC 3.3 V

18

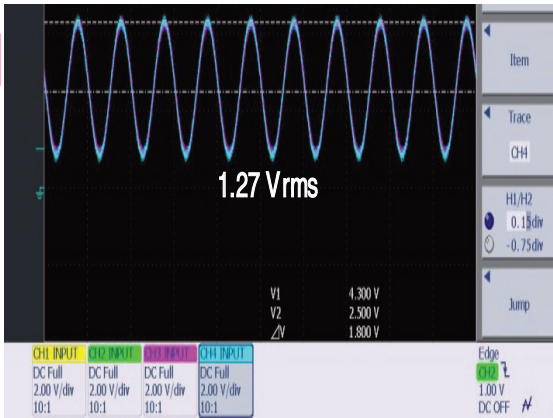
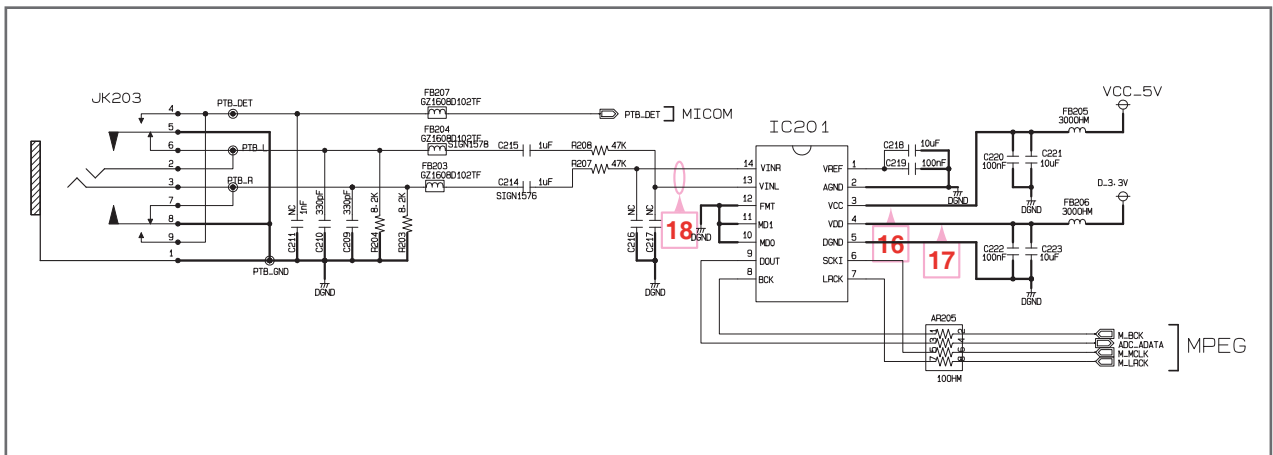

FIG 7-3. Analog Input Voltage



MEMO

A series of horizontal dotted lines for writing.

CIRCUIT VOLTAGE CHART

1. IC VOLTAGE

Designator	Description	Pin No	Pin Name	Voltage Spec	Measured Voltage	Temperature Spec.
IC101	IC, Microcontrollers	11	AVCC	1.8 V ~ 3.6 V	3.34 V	85 °C
		15, 40	DVCC	1.8 V ~ 3.6 V	3.34 V	
IC102	IC, Serial Flash Memory	8	VCC	2.7 V ~ 3.6 V	3.34 V	85 °C
IC103	IC, Serial Flash Memory	8	VCC	2.7 V ~ 3.6 V	3.33 V	85 °C
IC201	IC, A/D Converter	3	VCC	4.5 V ~ 5.5 V	5.15 V	125 °C
		4	VDD	2.7 V ~ 3.6 V	3.32 V	
IC301	IC, DC, DC Converter	4	VIN	2.7 V ~ 5.5 V	5.16 V	125 °C
		3	SW	0.6 V ~ 5.225 V	3.37 V	
IC302	IC, DC, DC Converter	2	VIN	+ 4.0 V ~ + 36 V	25.2 V	125 °C
		3	VOUT	0.8 V ~ 33 V	12.08 V	
IC303	IC, DC, DC Converter	4	VIN	2.7 V ~ 5.5 V	5.15 V	125 °C
		3	SW	0.6 V ~ 5.225 V	1.51 V	
IC304	IC, Analog Switch	5	VIN	2.5 V ~ 5.5 V	5.16 V	125 °C
		1	VOUT	0 V ~ 5.5 V	D_3.34V / PWM3.34V	
IC306	IC, Analog Switch	5	VIN	4.5 V ~ 5.5 V	5.17 V	110 °C
		1	VOUT		5.17 V (USB 5.16 V)	
IC308	IC, Analog Switch	5	VIN	4.5 V ~ 5.5 V	5.16 V	110 °C
		1	VOUT		5.14 V	
IC309	IC, Analog Switch	5	VIN	2.5 V ~ 5.5 V	5.16 V	125 °C
		1	VOUT	0 V ~ 5.5 V	D_3.34V	
IC311	IC, DC, DC Converter	4	VIN	2.7 V ~ 5.5 V	5.15 V	125 °C
		3	SW	0.6 V ~ 5.225 V	1.205 V	
IC501	IC, Video Processors		DVCC12_K	1.14 V ~ 1.26 V	1.21 V	95 °C
			DVCC33_IO	3.15 V ~ 3.45 V	3.32 V	
			DDRVCCIO1	1.425 V ~ 1.575 V	1.51 V	
			AVDD33	3.15 V ~ 3.45 V	3.32 V	
			AVDD12	1.14V ~ 1.26 V	1.21 V	
IC502	IC, DDR3 SDRAM	B2, D9, G7, K2, K8, N1, N9, R1, R9	VDD	1.5 V (± 0.075 V)	1.51 V	95 °C
		A1, A8, C1, C9, D2, E9, F1, H2, H9	VDDQ	1.5 V (± 0.075 V)	1.51 V	
IC503	IC, NOR Flash Memory	8	VCC	2.7 V ~ 3.6 V	3.32 V	85 °C
IC600	IC, Sound/Audio Processor	17, 52	VDD_IO	2.97 V ~ 3.63 V	3.33 V	85 °C
		6, 25	VDD_CORE	1.08 V ~ 1.32 V	1.24 V	
		34	VIN33_REG1	2.97 V ~ 3.63 V	3.33 V	
		66	VIN33_REG2	2.97 V ~ 3.63 V	3.3 V	
		68	VDD_PLL	1.08 V ~ 1.32 V	1.24 V	
IC700	IC, Audio Amplifier	1	GVDD_AB	-0.3 V ~ 13.2 V	11.7 V	125 °C
		22	GVDD_CD	-0.3 V ~ 13.2 V	11.7 V	
		36, 37, 38	PVDD_AB	-0.3 V ~ 50 V	25.5 V	
		29, 30, 31	PVDD_CD	-0.3 V ~ 50 V	25.5 V	
		2	VDD	-0.3 V ~ 13.2 V	11.9 V	
		8	DVDD	-0.3 V ~ 4.2 V	3.306 V	
		13	13 AVDD	-0.3 V ~ 8.5 V	7.8 V	
IC701	IC, Audio Amplifier	1	GVDD_AB	-0.3 V ~ 13.2 V	11.7 V	125 °C
		22	GVDD_CD	-0.3 V ~ 13.2 V	11.7 V	
		36, 37, 38	PVDD_AB	-0.3 V ~ 50 V	25.5 V	
		29, 30, 31	PVDD_CD	-0.3 V ~ 50 V	25.5 V	
		2	VDD	-0.3 V ~ 13.2 V	11.9 V	
		8	DVDD	-0.3 V ~ 4.2 V	3.304 V	
		13	AVDD	-0.3 V ~ 8.5 V	7.8 V	
IC803	IC, DC, DC Converter	1	VIN	4.2 V ~ 17 V	12.1 V	125 °C
		2	SW	0.8 V ~ 10 V	5.17 V	

2. CAPACITOR VOLTAGE

Designator	Description	SPEC	Real Value (#1, #2)/ V					Temperature Spec.
C390, C734, C769	Capacitor, AL, Chip	330 uF/ 35 V	25.76	25.75	25.78	25.81	25.76	-40 ~ 105 °C/ 2000 HR
WC706	Capacitor, AL, Chip	100 uF/ 16 V	3.42	3.41	3.42	3.42	3.41	-55 ~ 105 °C/ 2000 HR
WC904	Capacitor, AL, Radial	100 uF/ 460 V	155.3	155.4	155.4	155.29	155.4	-25 ~ 105 °C/ 2000 HR
WC917	Capacitor, AL, Chip	47 uF/ 50 V	20.15	20.22	20.22	20.16	20.2	-55 ~ 105 °C/ 2000 HR
WC924, WC925, WC926	Capacitor, AL, Radial	1000 uF/ 50 V	34.9	34.88	34.9	34.93	34.88	-55 ~ 105 °C/ 2000 HR

3. CONNECTOR VOLTAGE

CN102 (MAIN <-> BT)			
Power	MAIN	BT module	SPEC
3.3 VA	3.33 V	3.32 V	3.3 VA (1.7 V ~ 3.6 V)
CN107 (MAIN <-> Wireless)			
Power	MAIN	Wireless module	SPEC
WL_3V3	3.308 V	3.304 V	3.3 V (3.15 V ~ 3.45 V)
CN108 (MAIN <-> Rear Wireless)			
Power	MAIN	Wireless module	SPEC
3.3 VA	3.33 V	3.302 V	3.3 V (3.15 V ~ 3.45 V)

PRINTED CIRCUIT BOARD DIAGRAMS

1. MAIN P. C. BOARD DIAGRAM

(TOP VIEW)

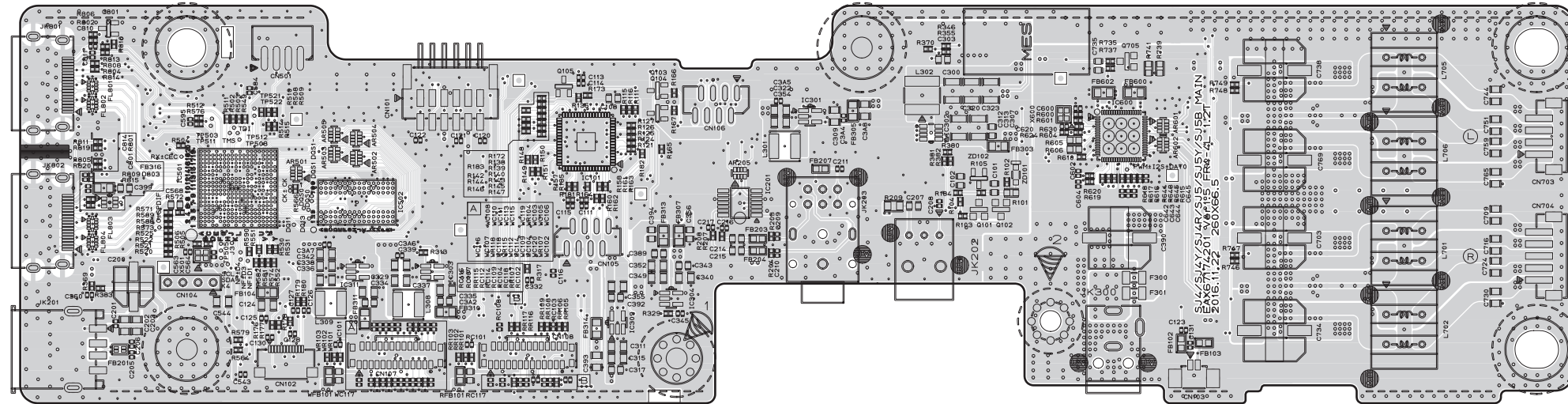

(BOTTOM VIEW)

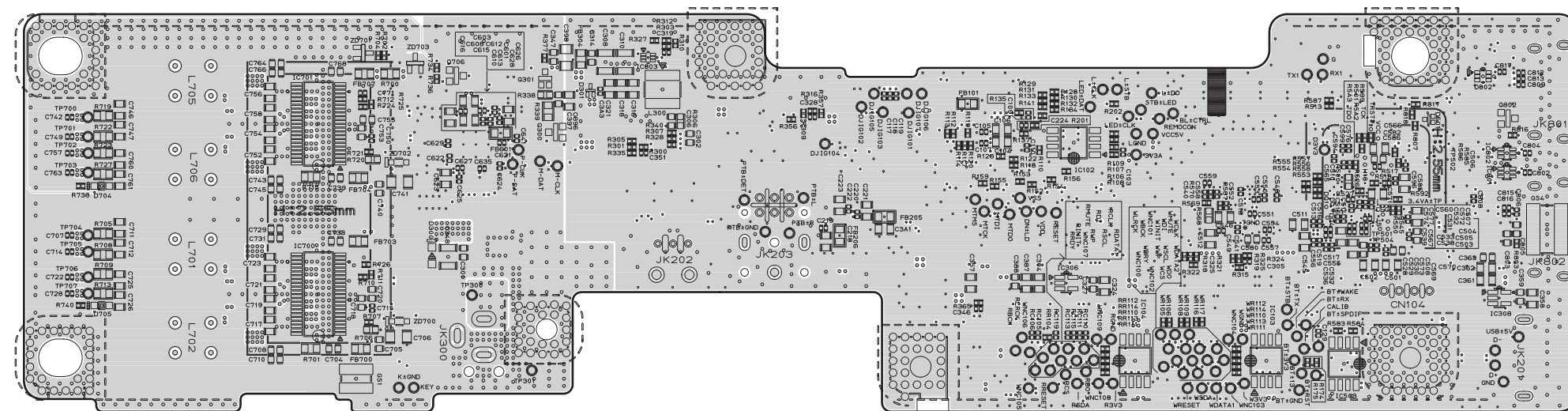

SECTION 4

WIRELESS SUBWOOFER PART

CONTENTS

WIRING DIAGRAM	4-2
BLOCK DIAGRAM	4-3
ONE POINT REPAIR GUIDE	4-4
1. POWER ON ERROR	4-4
2. WIRELESS CONNECTION	4-6
WAVEFORMS OF MAJOR CHECK POINT	4-7
1. CRYSTAL.....	4-7
2. FLASH MEMORY	4-7
3. VOLTAGE	4-8
4. AMP VOLTAGE	4-9
5. PWM	4-10
6. LED	4-11
CIRCUIT VOLTAGE CHART	4-13
PRINTED CIRCUIT BOARD DIAGRAMS	4-15
1. WOOFER SMPS & AMP P. C. BOARD	4-15

WIRING DIAGRAM

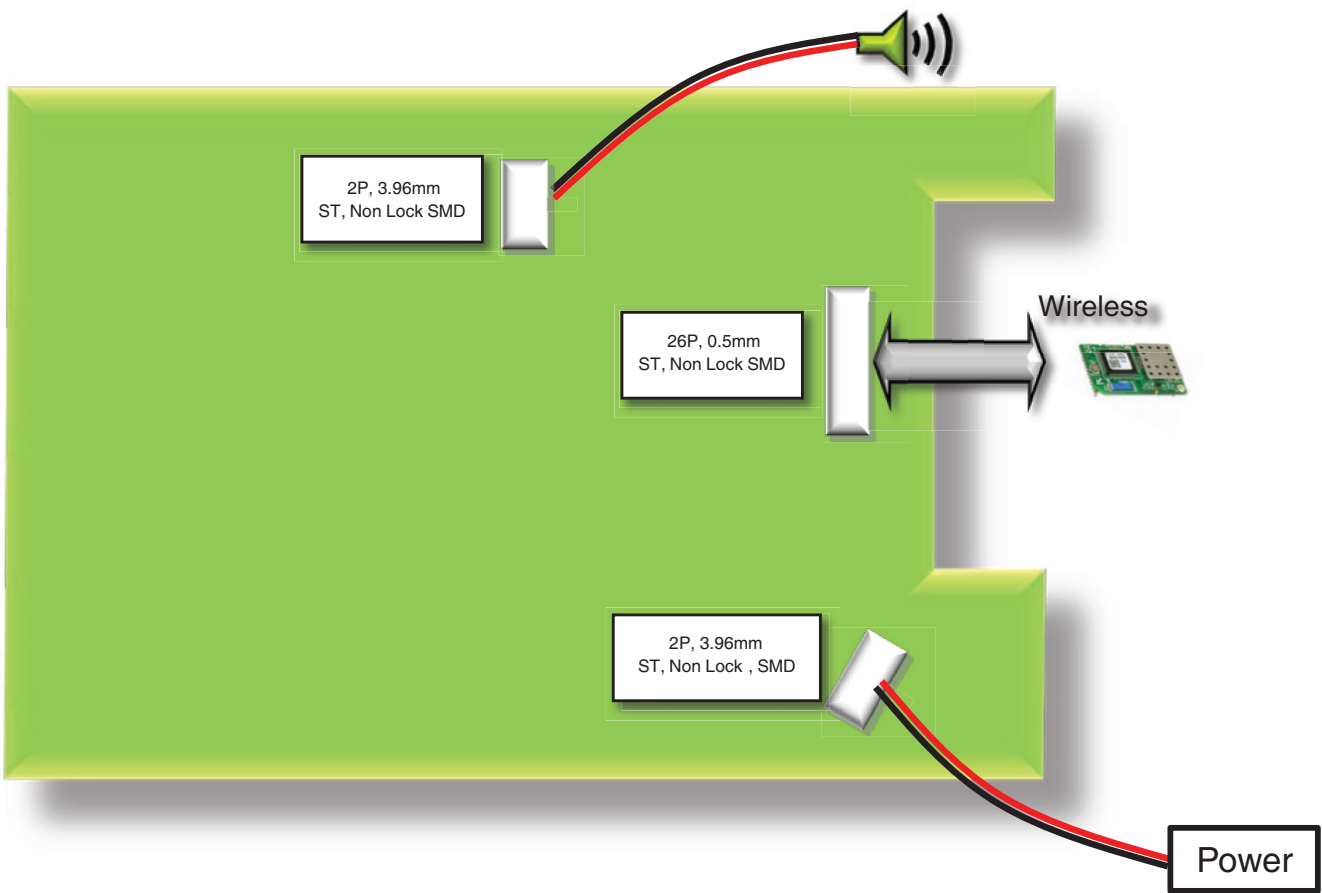

BLOCK DIAGRAM

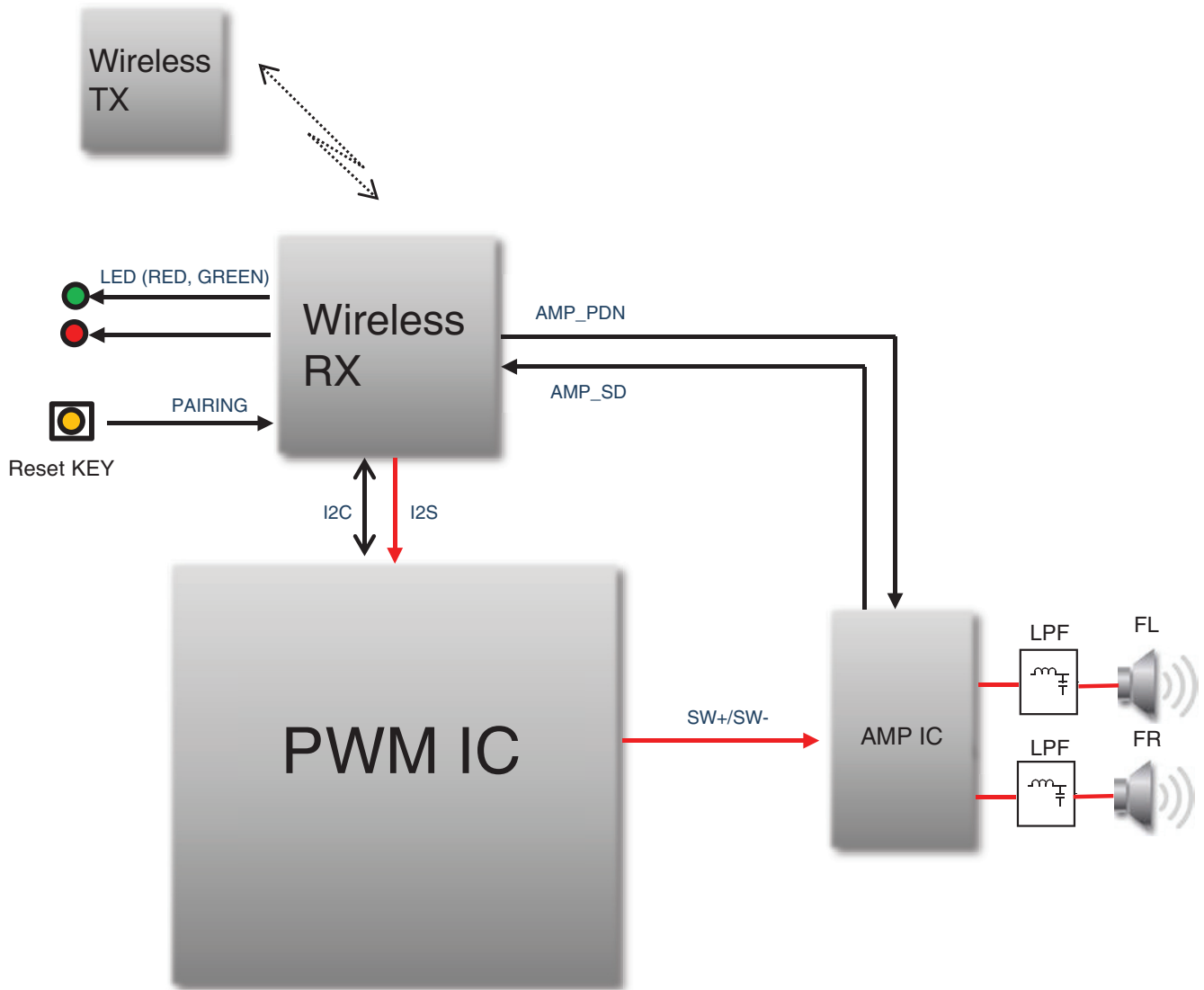

ONE POINT REPAIR GUIDE

2. WIRELESS CONNECTION

Wireless connection malfunction.

2-1. 3.3 VA

1) Check 3.3 VA at WFB604.

2-2. Connection

1) Wireless module connection closely.

2) Implement Wireless Factory Reset.

➔ MAIN SET : Soundbar vol MIN and push Mute key (sustain 3 ~ 5 seconds).

➔ Subwofer : ❶ Press **Pairing** button on the rear of the wireless subwoofer.

❷ The LED of of the wireless subwoofer blink red and green, pull out power cord.

❸ The main set and the wireless subwoofer are factory reset mode, then power on.

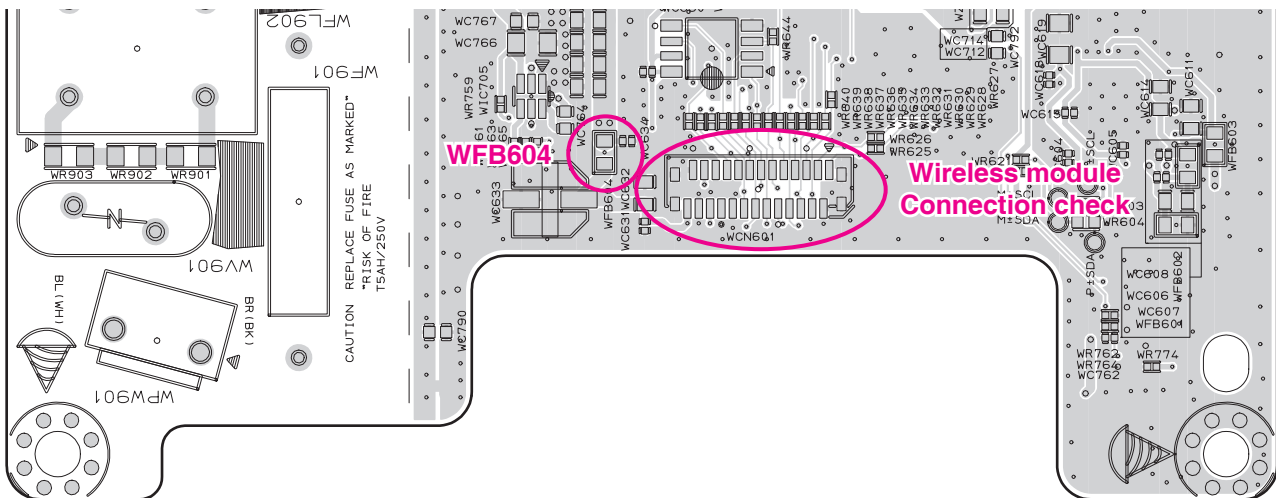

< Woofer SMPS & AMP board top view >

WAVEFORMS OF MAJOR CHECK POINT

1. CRYSTAL

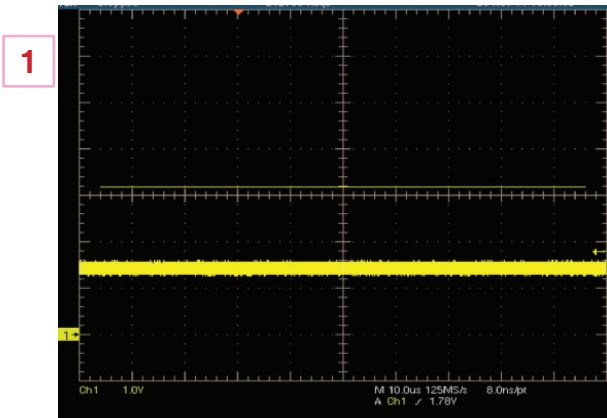
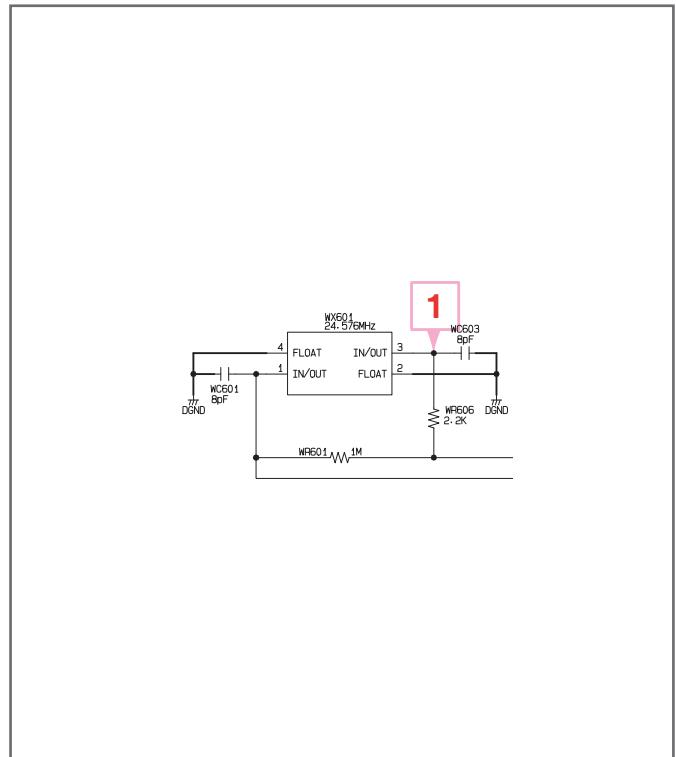

FIG 1. WX601 (24.576 MHz)



2. FLASH MEMORY

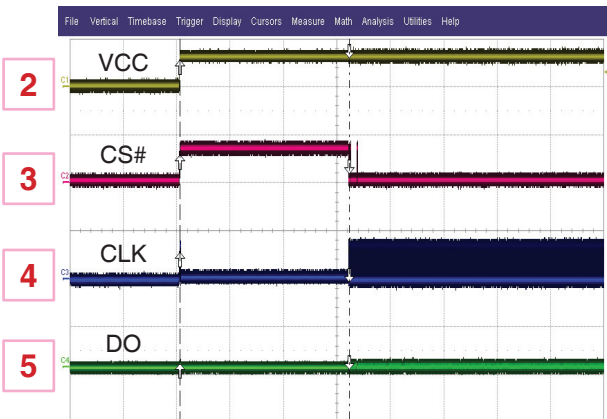
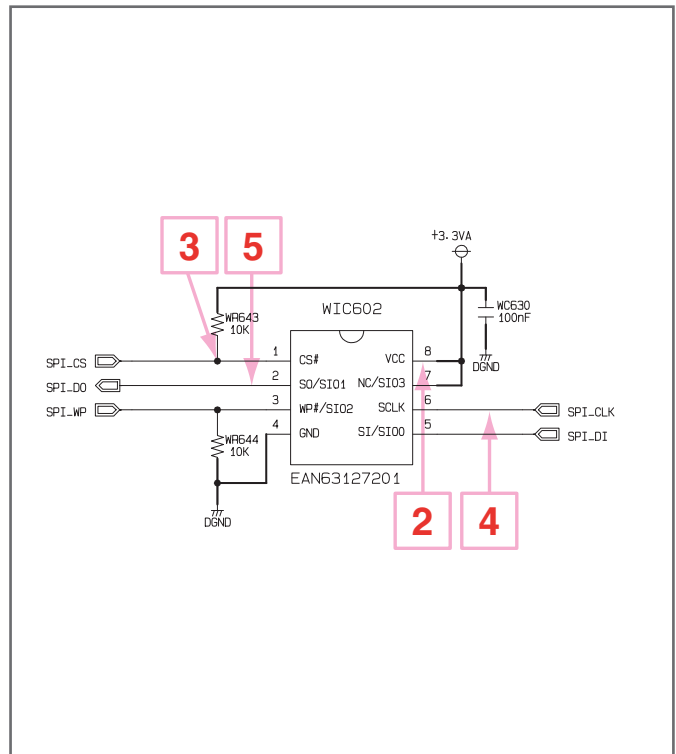

FIG 2. VCC, CS#, CLK, DO



3. VOLTAGE

6



FIG 3-1. Woofer PVDD

7



FIG 3-2. Woofer 12 VA

8

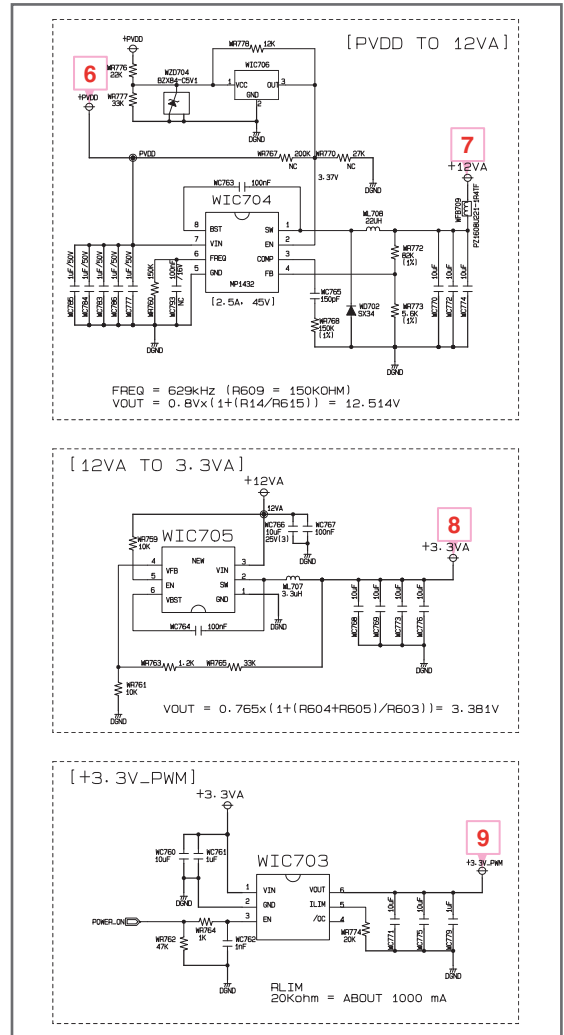

FIG 3-3. Woofer 3.3 VA

9



FIG 3-4. Woofer 3.3V_PWM



4. AMP VOLTAGE

10

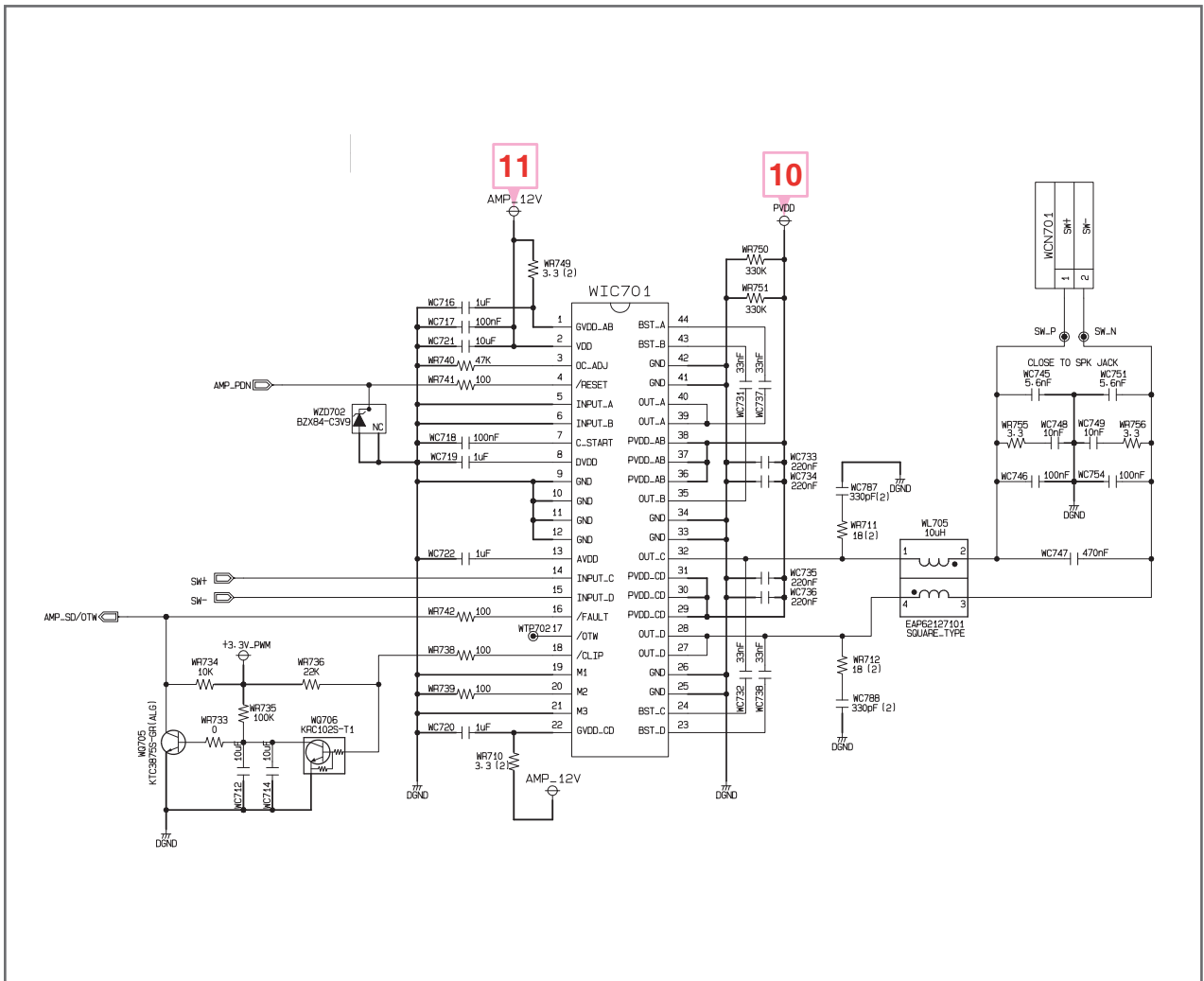

FIG 4-1. AMP PVDD

11



FIG 4-2. AMP_12V



6. LED



FIG 6-1. Pairing Off Status → Red LED

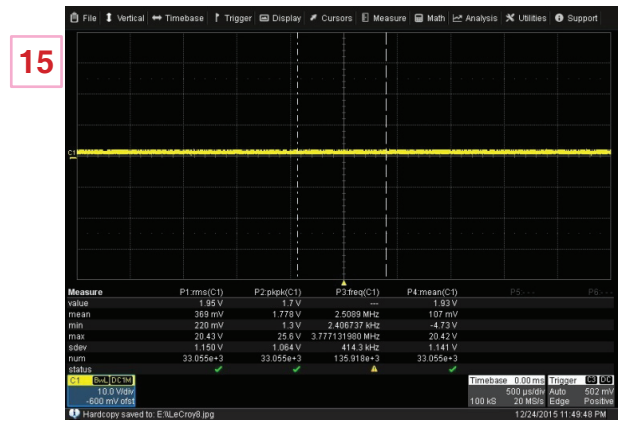
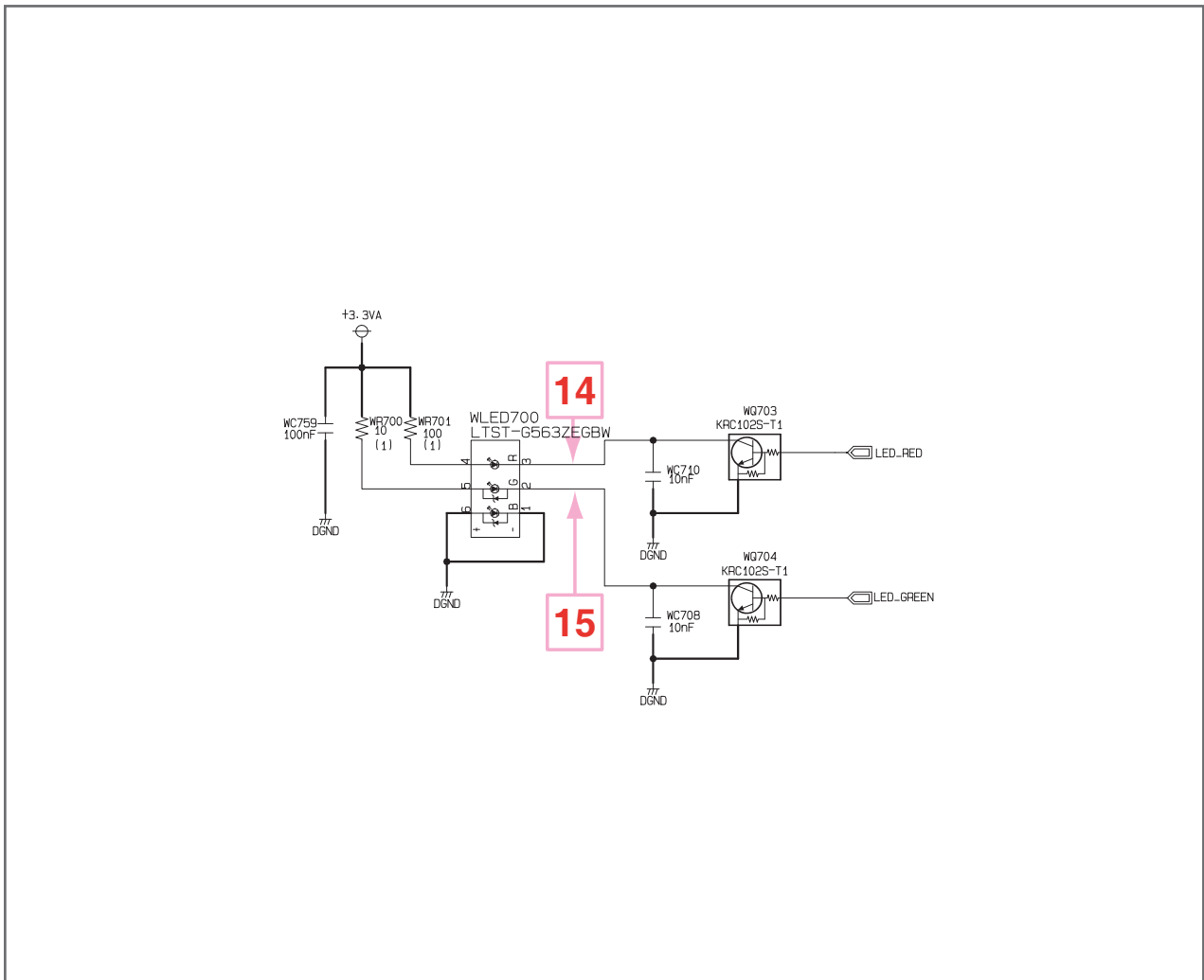

FIG 6-2. Pairing On Status → Green LED



PRINTED CIRCUIT BOARD DIAGRAMS

1. WOOFER SMPS & AMP P. C. BOARD

(TOP VIEW)

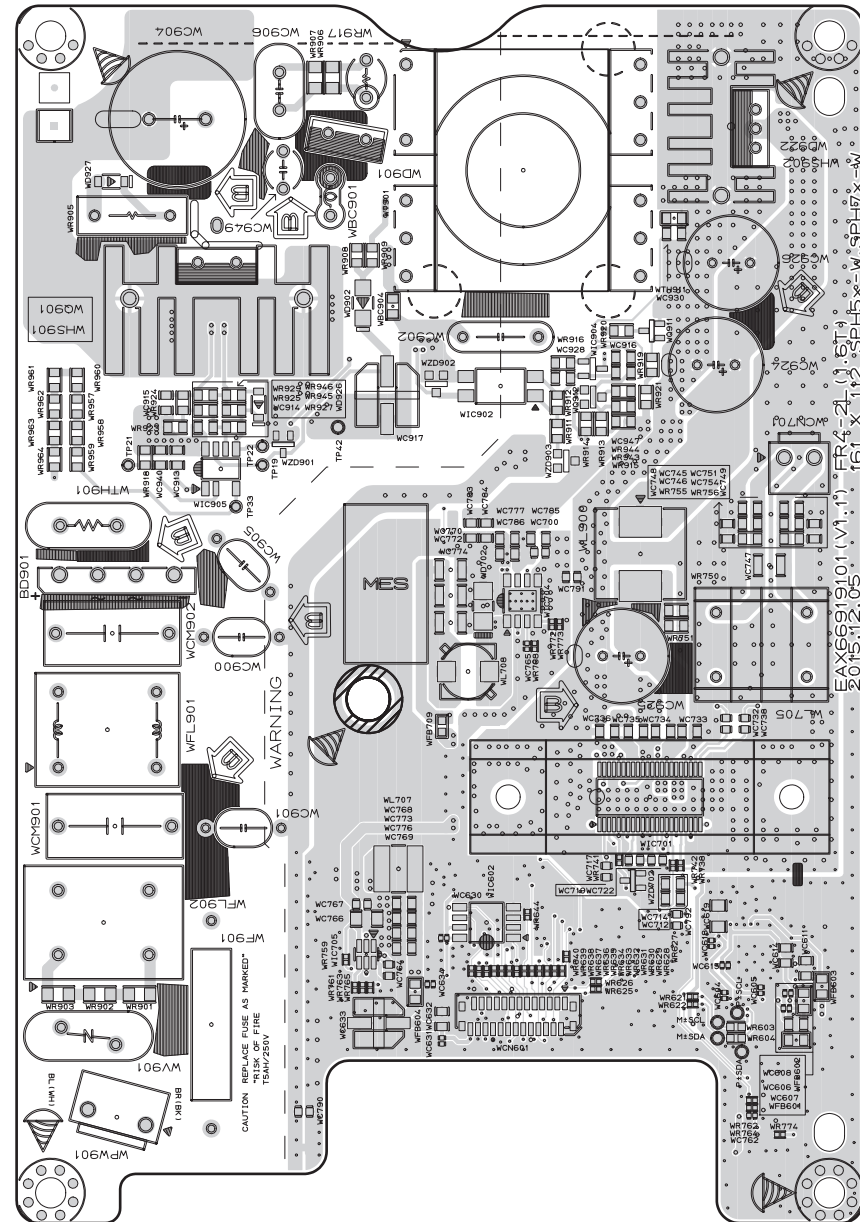

(BOTTOM VIEW)

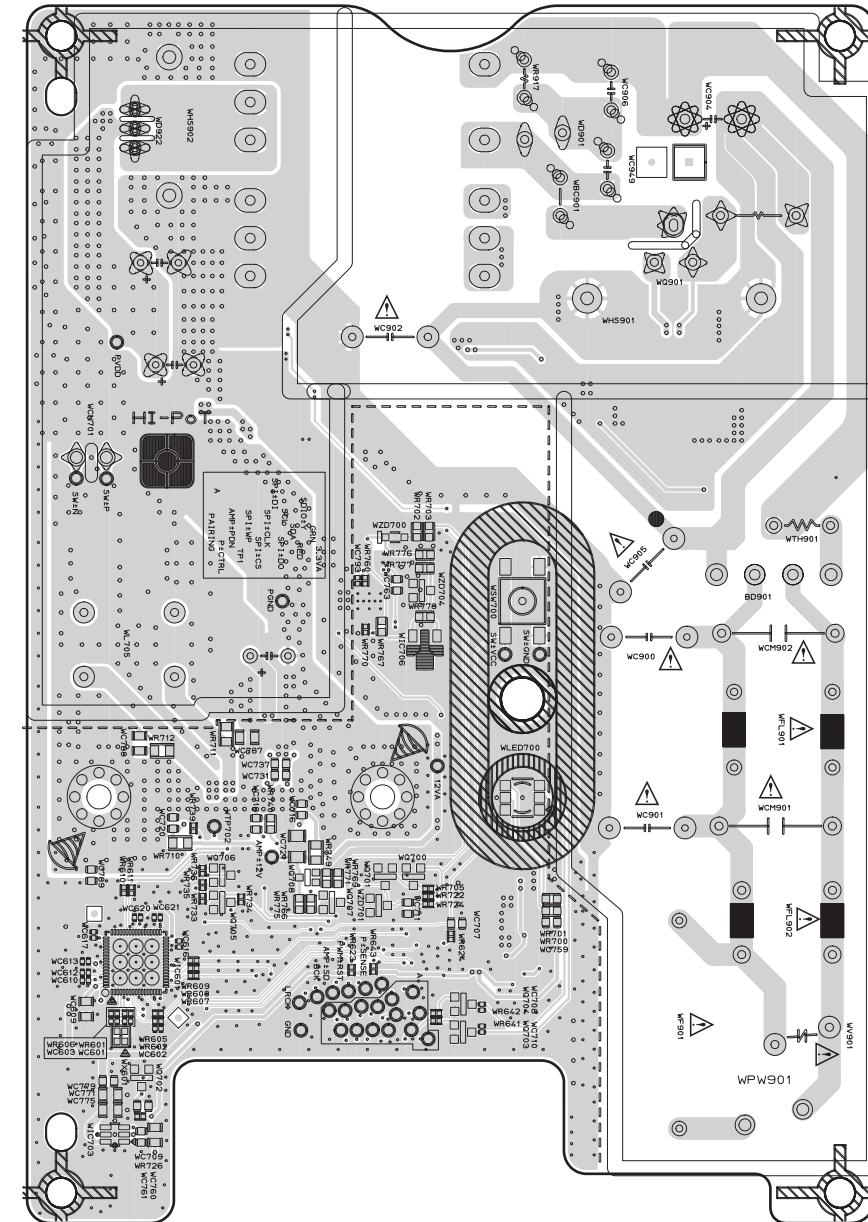

(NOTE) Warning
 ⚠ Parts that are critical with respect to risk of fire or electrical shock.

SECTION 5

WIRELESS RECEIVER PART (OPTION)

CONTENTS

WIRING DIAGRAM	5-2
BLOCK DIAGRAM	5-3
ONE POINT REPAIR GUIDE	5-4
ELECTRICAL TROUBLESHOOTING GUIDE.....	5-5
WAVEFORMS.....	5-7
PRINTED CIRCUIT BOARD DIAGRAMS	5-9
1. WIRELESS RECEIVER SMPS P. C. BOARD	5-9
2. WIRELESS RECEIVER AMP P. C. BOARD	5-11

WIRING DIAGRAM

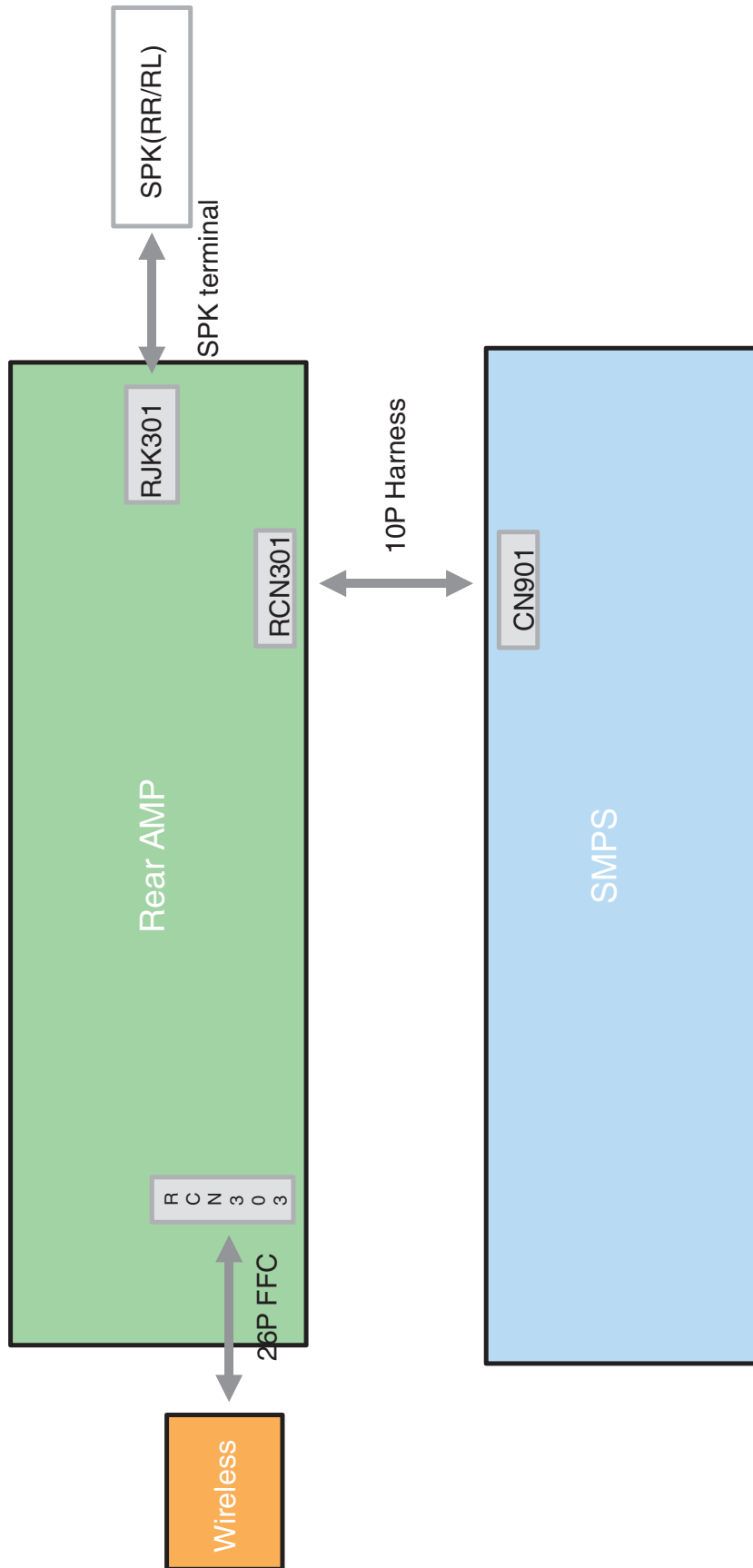

BLOCK DIAGRAM

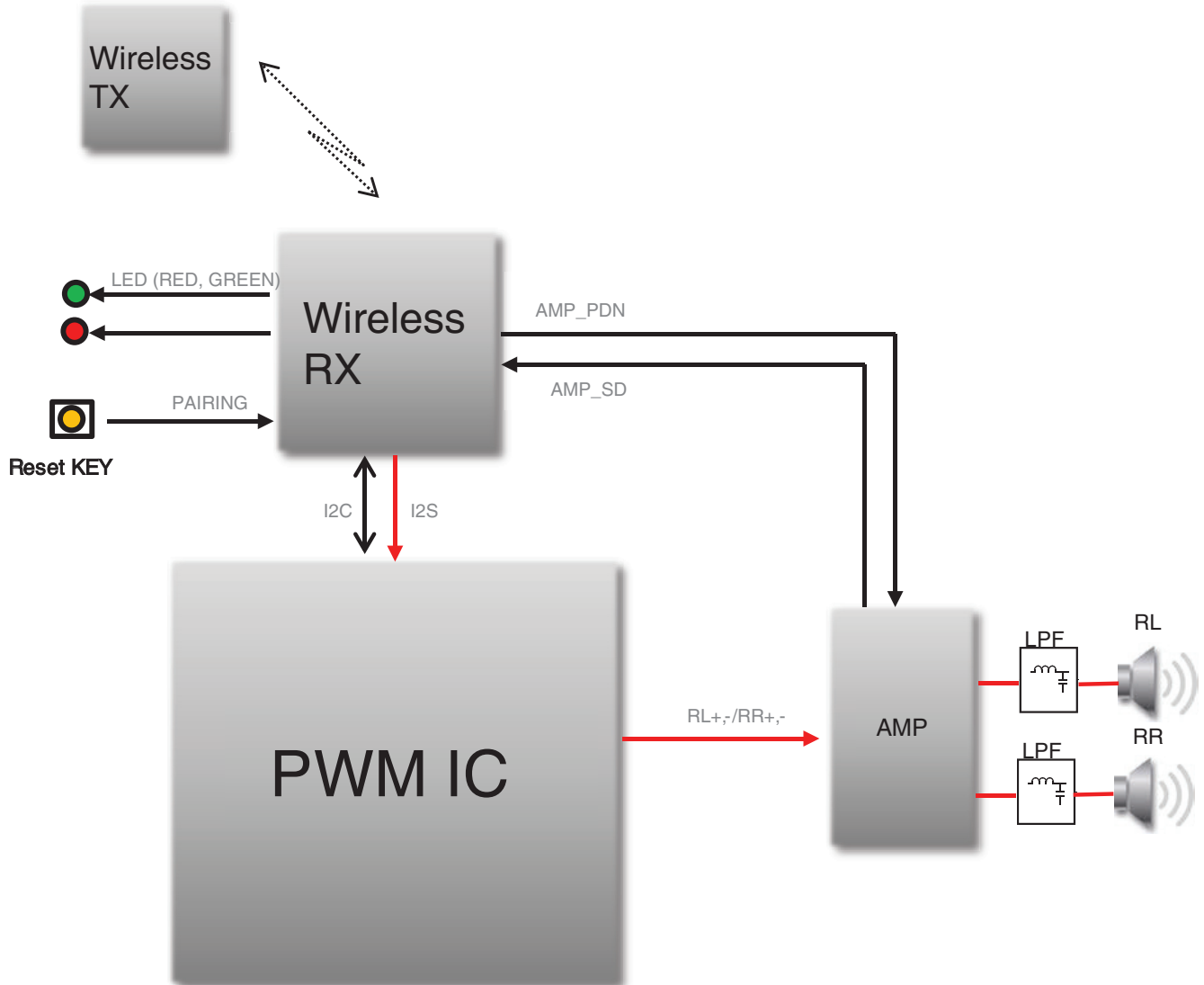

ONE POINT REPAIR GUIDE

1. How to Duplicate Problem

Wireless rear speaker doesn't output a sound.

1-1. Solution

Replace SMPS board (No PVDD).

1-2. How to troubleshoot (Countermeasure)

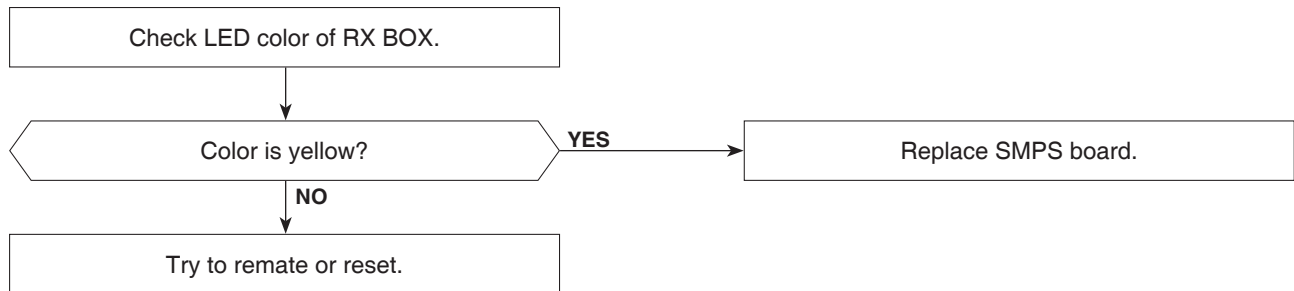

2. How to Duplicate Problem

Wireless rear speaker doesn't output a sound.

2-1. Solution

Replace AMP board (No 12 V).

2-2. How to troubleshoot (Countermeasure)

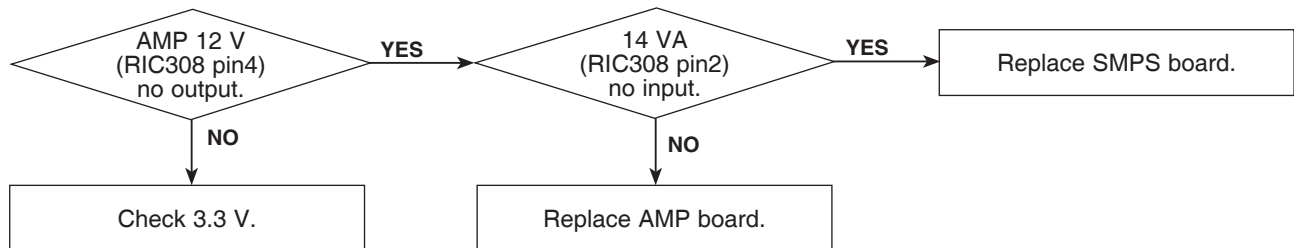

2-3. Service hint (Any picture / Remark)

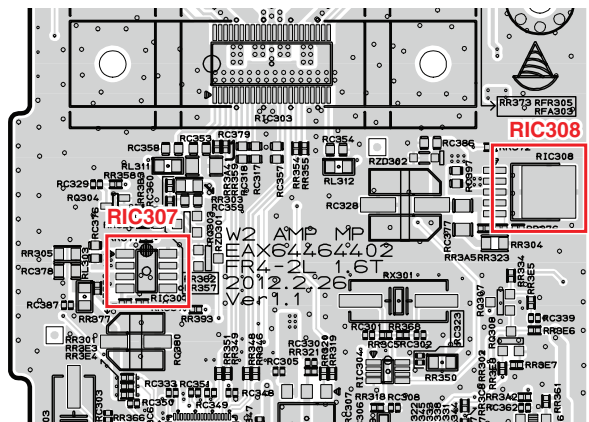

< AMP board top view >

ONE POINT REPAIR GUIDE

3. How to Duplicate Problem

Wireless rear speaker doesn't output a sound.

3-1. Solution

Replace AMP board (No 3.3 V).

3-2. How to troubleshoot (Countermeasure)

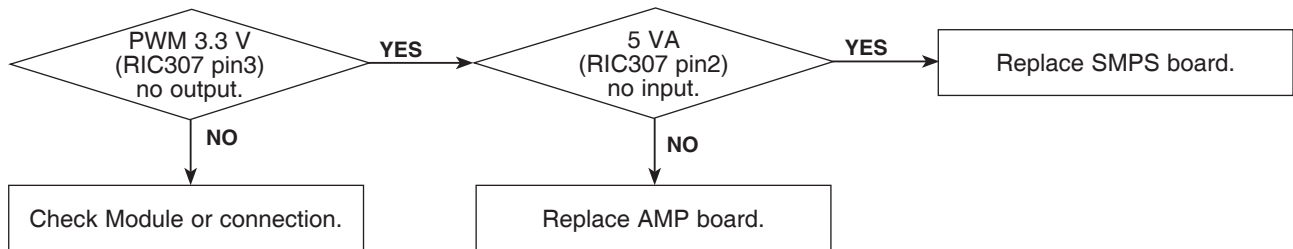

3-3. Service hint (Any picture / Remark)

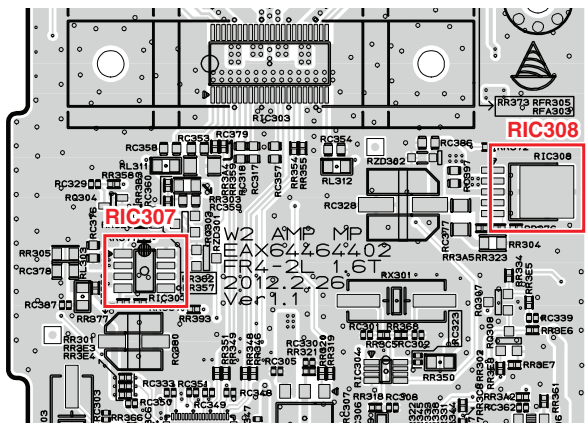

< AMP board top view >

ELECTRICAL TROUBLESHOOTING GUIDE

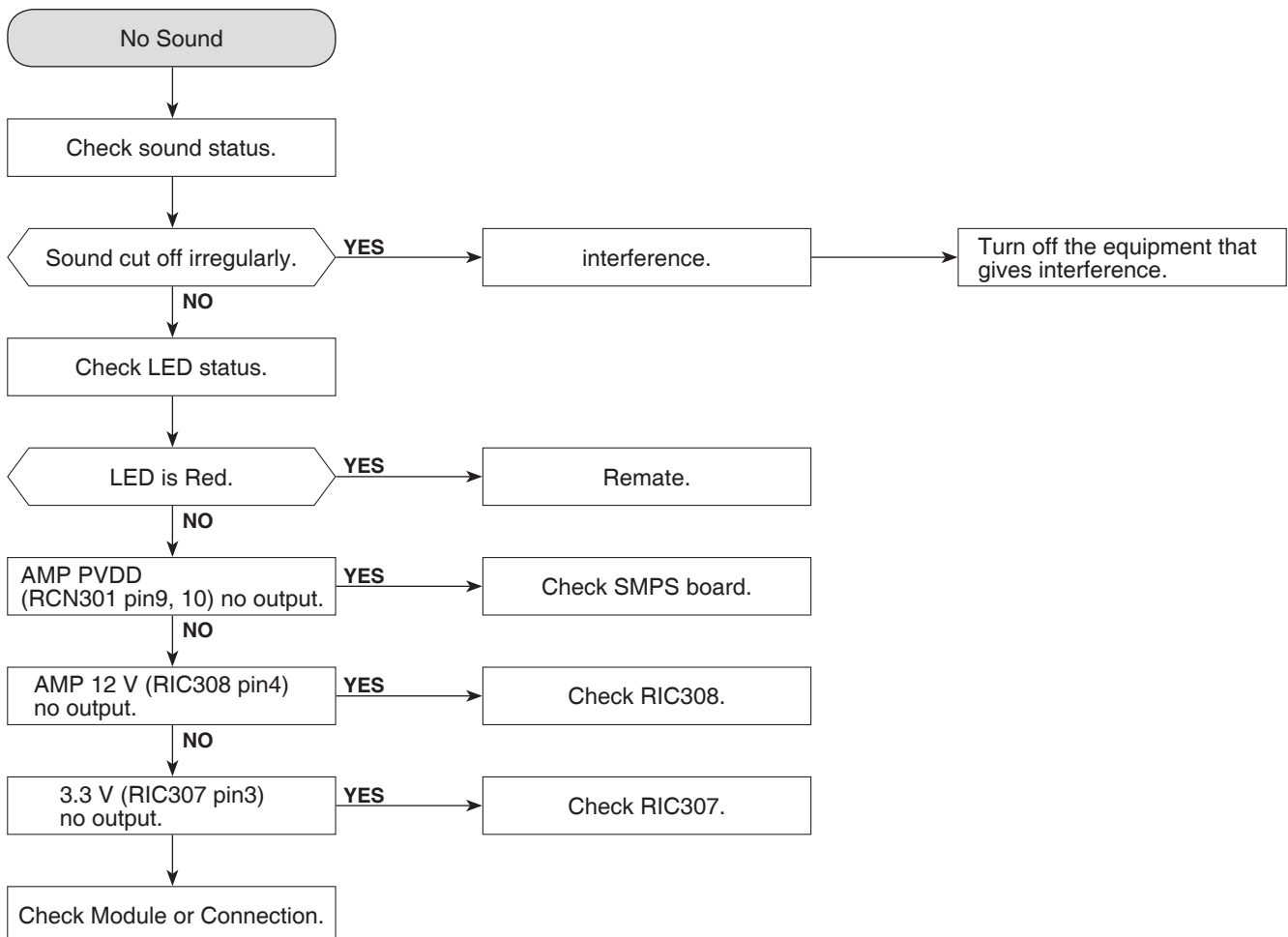
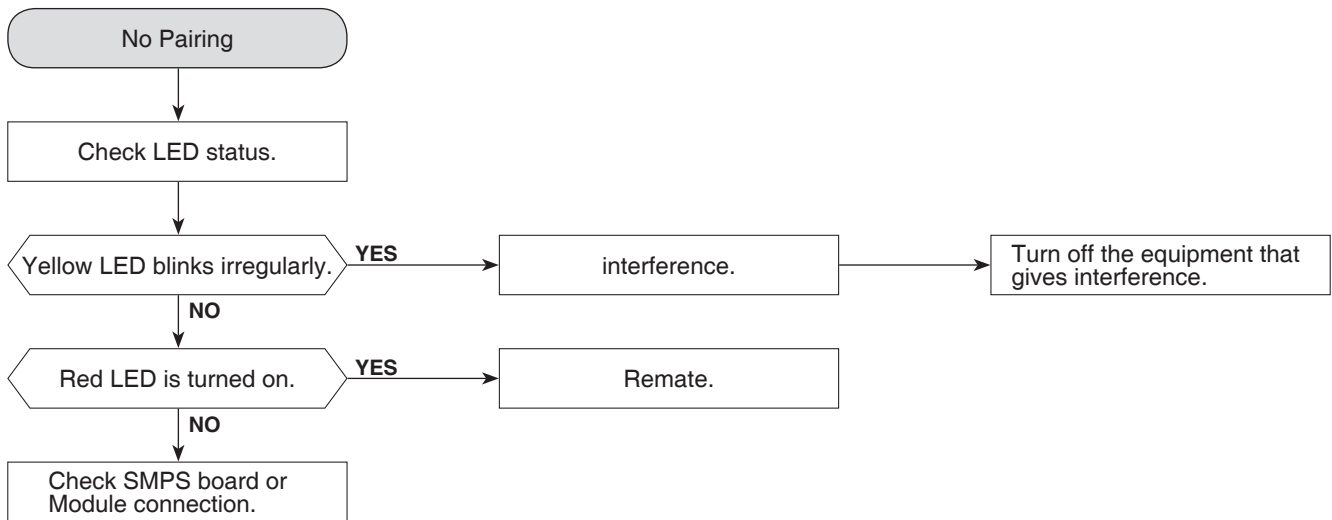

WAVEFORMS

1. AUDIO PART (I2S)

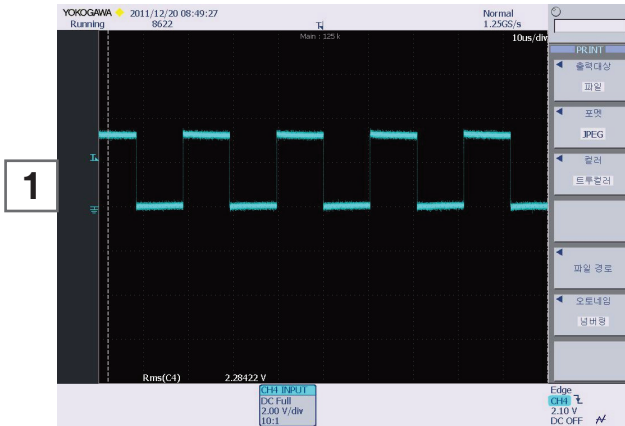

RCN303 pin1 : I2S LRCK

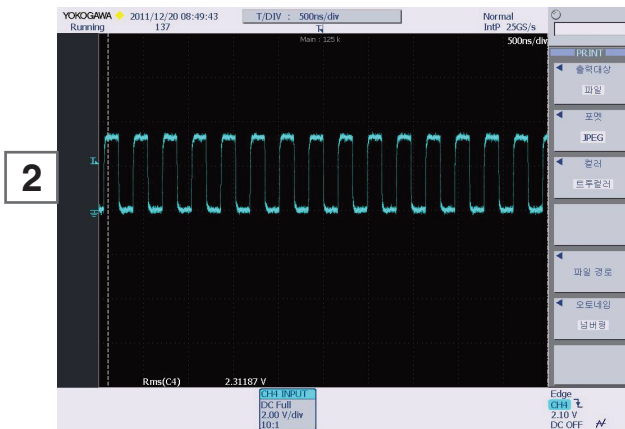

RCN303 pin3 : I2S BCK

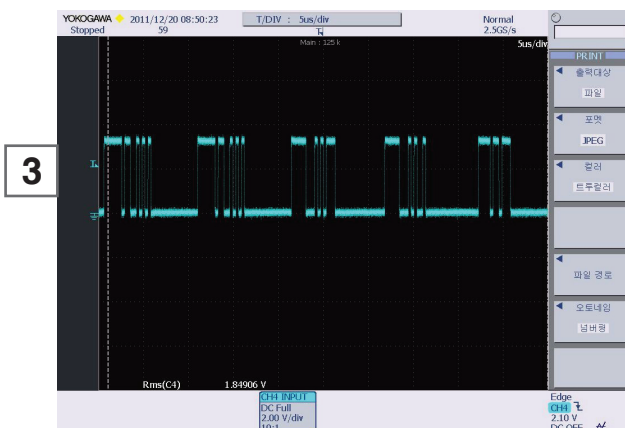

RCN303 pin20 : I2S Audio Data

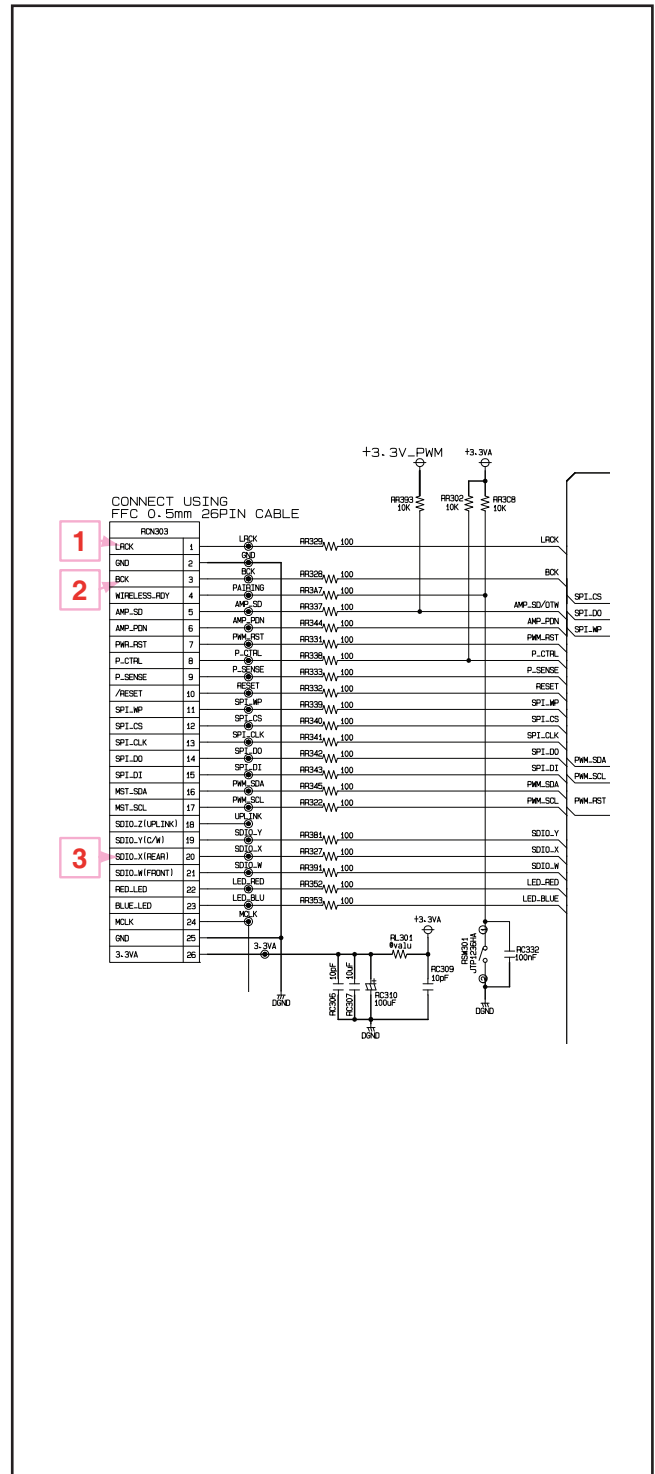

MEMO

A series of horizontal dotted lines for writing.

